

SEVENTH EDITION



Ripped by  
Dr. Prodigions

# JEFFCOATE'S PRINCIPLES OF GYNAECOLOGY

*Revised and Updated by*  
**Pratap Kumar**  
**Narendra Malhotra**

**JAYPEE**

**JEFFCOATE'S**  
**PRINCIPLES OF GYNAECOLOGY**

---

# JEFFCOATE'S PRINCIPLES OF GYNAECOLOGY

---

Seventh International Edition

*Revised and updated from the sixth edition by*

**Pratap Kumar** MD FICOG  
Prof. and Head, Department of Obstetrics and Gynaecology  
Kasturba Medical College, Manipal, Karnataka (India)

**Narendra Malhotra** MD FICOG  
Consultant and Director  
MNMH (P) Ltd., Agra  
Apollo Pankaj Hospital (P) Ltd., Agra (India)  
President, Federation of Obstetric  
and Gynaecological Societies of India-2008



**JAYPEE BROTHERS MEDICAL PUBLISHERS (P) LTD**

New Delhi • Ahmedabad • Bengaluru • Chennai • Hyderabad • Kochi • Kolkata • Lucknow • Mumbai • Nagpur

*Published by*

Jitendar P Vij

**Jaypee Brothers Medical Publishers (P) Ltd**

B-3, EMCA House, 23/23B Ansari Road, Daryaganj

**New Delhi** 110 002, India

Phones: +91-11-23272143, +91-11-23272703, +91-11-23282021, +91-11-23245672, Rel: +91-11-32558559

Fax: +91-11-23276490, +91-11-23245683 e-mail: jaypee@jaypeebrothers.com

Visit our website: www.jaypeebrothers.com

### Branches

- 2/B, Akroti Society, Jodhpur Gam Road Satellite  
**Ahmedabad** 380 015 Phones: +91-79-26926233, Rel: +91-79-32988717, Fax: +91-79-26927094  
e-mail: ahmedabad@jaypeebrothers.com
- 202 Batavia Chambers, 8 Kumara Krupa Road, Kumara Park East  
**Bengaluru** 560 001 Phones: +91-80-22285971, +91-80-22382956, +91-80-22372664, Rel: +91-80-32714073  
Fax: +91-80-22281761 e-mail: bangalore@jaypeebrothers.com
- 282 IIIrd Floor, Khaleel Shirazi Estate, Fountain Plaza, Pantheon Road  
**Chennai** 600 008 Phones: +91-44-28193265, +91-44-28194897, Rel: +91-44-32972089  
Fax: +91-44-28193231 e-mail: chennai@jaypeebrothers.com
- 4-2-1067/1-3, 1st Floor, Balaji Building, Ramkote Cross Road  
**Hyderabad** 500 095 Phones: +91-40-66610020, +91-40-24758498, Rel: +91-40-32940929  
Fax: +91-40-24758499, e-mail: hyderabad@jaypeebrothers.com
- No. 41/3098, B & B1, Kuruvi Building, St. Vincent Road  
**Kochi** 682 018, Kerala Phones: +91-484-4036109, +91-484-2395739, +91-484-2395740  
e-mail: kochi@jaypeebrothers.com
- 1-A Indian Mirror Street, Wellington Square  
**Kolkata** 700 013 Phones: +91-33-22651926, +91-33-22276404, +91-33-22276415, Rel: +91-33-32901926  
Fax: +91-33-22656075, e-mail: kolkata@jaypeebrothers.com
- Lekhraj Market III, B-2, Sector-4, Faizabad Road, Indira Nagar  
**Lucknow** 226 016 Phones: +91-522-3040553, +91-522-3040554 e-mail: lucknow@jaypeebrothers.com
- 106 Amit Industrial Estate, 61 Dr SS Rao Road, Near MGM Hospital, Parel  
**Mumbai** 400012 Phones: +91-22-24124863, +91-22-24104532, Rel: +91-22-32926896  
Fax: +91-22-24160828, e-mail: mumbai@jaypeebrothers.com
- "KAMALPUSHPA" 38, Reshimbag, Opp. Mohota Science College, Umred Road  
**Nagpur** 440 009 (MS) Phone: Rel: +91-712-3245220, Fax: +91-712-2704275 e-mail: nagpur@jaypeebrothers.com

### Jeffcoate's Principles of Gynaecology

© 2008, Arnold

All rights reserved. No part of this publication should be reproduced, stored in a retrieval system, or transmitted in any form or by any means: electronic, mechanical, photocopying, recording, or otherwise, without the prior written permission of the editors and the publisher.

This book has been published in good faith that the material provided by editors is original. Every effort is made to ensure accuracy of material, but the publisher, printer and editors will not be held responsible for any inadvertent error(s). In case of any dispute, all legal matters are to be settled under Delhi jurisdiction only.

*First Edition* : 1957

*Fifth Edition* : 1987

*Sixth Edition* : 2001

*Seventh Edition* : **2008**

ISBN : 978-81-8448-288-1

*Typeset at* JPBMP typesetting unit

*Printed at* Ajanta

# Preface to the Seventh International Edition

We both, Dr Prof Pratap Kumar and Dr Narendra Malhotra feel very honoured for being asked to revise the best textbook on gynaecology by Sir Norman Jeffcoate.

In the rapidly advancing age of technology and rapidly changing trends in management, diagnosis, drugs and procedures, it is of paramount importance to update books and manuals periodically. This book was earlier updated and edited by Dr Neerja Bhatla in the year 2001, an International Edition (Sixth edition), but soon the publishers felt the need for revising it within a span of five years.

Prof Norman had expressed in 1974 that he had endeavoured to preserve his personal approach.

We have added many new chapters and rewritten a few chapters all together trying to maintain Sir Jeffcoate's style. We have retained the description of Professor Jeffcoate's original case discussions, photographs and pictures.

We hope that the undergraduate and the postgraduate students will appreciate our efforts to update this "*Bible*" of Gynaecology.

**Pratap Kumar  
Narendra Malhotra  
2008**

# Preface to the Fifth Edition

It was inevitable that following Professor Sir Norman Jeffcoate's retirement there would be pressure to continue to publish the *Principles of Gynaecology*.

In the last revision in 1974 Sir Norman emphasised that he had endeavoured to preserve his personal approach, bearing in mind the objectives and principles outlined in the preface to the First Edition. In addition, some of Sir Norman's comments in the preface to his Fourth Edition are included to emphasize the guidelines the present author has taken in an attempt to maintain the format of the *Principles of Gynaecology*.

Much of the material presented is retained from the last edition, since it also reflects the gynaecological training of the author under Professor Jeffcoate in Liverpool. The views expressed are therefore personal ones from a pupil of Sir Norman Jeffcoate against the background of all the information available. Once given, the views expressed mean that references are excluded for the special reasons given in the preface to the First Edition.

In the process of being taught obstetrics and gynaecology by Sir Norman, one was encouraged to consider all the facts about a case, to come to a conclusion and to be able to justify it. Even though a critical approach to each case was expected, we were never allowed to forget that we were dealing with a woman, mother or child with a personal problem. Indeed, Professor Jeffcoate's personal approach was such that in a clinic with many students and postgraduates present, it was obvious that as far as the patient was concerned Sir Norman was the only person there. I have never been able to achieve the same effect, but I hope that my efforts in revising this book will be acceptable to an outstanding teacher, guide and friend. If so, then I am sure it will benefit all those who read it.

**Victor Tindall**  
1986

# Extracts from the Preface to the First Edition

The book is meant to add to rather than replace clinical and tutorial instruction, so those matters which can best be taught beside the patient, or which are easy for any student to learn and understand from other sources, receive little attention. In planning the text I recalled those subjects which I myself found (and still do find) difficult to master, or on which I had to search far and long for information, and gave them disproportionate emphasis. This and other considerations resulted in a disregard for the relative importance - as judged by their clinical frequency - of different conditions. Indeed, the reader will find that quite rare conditions are mentioned, illustrated or described at length; and that all manner of asides - even some with an obstetrical flavour — creep in. This is partly because they are of special interest to me but mainly because they appeared to offer scope for presenting an attitude of mind; for discouraging loose thinking and empiricism; for inculcating a scientifically and ethically honest outlook; for emphasising the Art as well as the Science of gynaecology.

I have not played safe by stating only generally accepted views, nor have I played fair by giving the differing views of various authorities. Instead, after weighing the evidence, I have attempted to reach a conclusion which satisfies me as being as rational as present knowledge allows. Without intended disrespect, mention by name of authors and workers has been avoided as a rule; references clutter up the text, destroy continuity and are hardly ever used properly. On the other hand, I have not hesitated to give my own views and have, at times, been more dogmatic than clinical experience ever really justifies. I have even gone so far as to enunciate ideas which in many respects are conjectural if not fanciful. I do not expect these all to be accepted; if they are I shall be disappointed because their object is to provoke trains of thought and discussion.

In offering this book to fellow students I remember with affection and gratitude W Blair-Bell, one of the great gynaecologists of this century. He not only taught me gynaecology and a particular approach to it, he taught me to think and to write. He, more than anyone else, provided me with the stimulus and the opportunity to obtain the experience which has led to this work.

**Norman Jeffcoate**  
1957

# Acknowledgements

A mammoth project like revising Sir Norman Jeffcoate's Principles of Gynaecology requires lots of help from colleagues.

We are grateful to all those who have helped us to do this mammoth job. Special appreciation and thanks are to:

1. Thank you doctors and staff of Department of Obstetrics and Gynaecology, Kasturba Medical College, Manipal, Karnataka.
2. Thank you junior doctors of MNMH (P) Ltd. and Apollo Pankaj Hospital (P) Ltd, Agra.
3. Our special thanks to the following, who have given valuable suggestions in various chapters: Prof Barun Sarkar, Prof Arun Nagrath, Dr Richa Singh, Dr Anju Sharma, Dr Alka Saraswat, Dr Jaideep Malhotra, Dr Anupam Gupta and Dr Neharika of Agra, Dr Sunder Rajan (Pondicherry), Dr Kavita Singh (Jabalpur), Dr Col R Puri (Jalandhar), Dr Sakshi Tomar (PGI Lucknow), Dr Maninder Ahuja (Faridabad).
4. Special thanks to Dr Pranay Shah of Mumbai for contributing Chapter on Laparoscopy and Dr Richa Saxena for editing the manuscript.

We both are thankful to our families for bearing with us and sharing family time for work like this. Thank you Vidya, Dr Prabha Malhotra, Dr Jaideep Malhotra, Deepali, Deepika, Dr RM Malhotra, Kehsav and Neharika.

We hope that our efforts will be appreciated.



# Contents

<b>1. A Clinical Approach to Gynaecology .....</b>	<b>1</b>
<b>2. Anatomy .....</b>	<b>21</b>
<b>3. Ovarian Functions .....</b>	<b>56</b>
<b>4. Menstruation and Other Cyclical Phenomena .....</b>	<b>79</b>
<b>5. Clinical Aspects of Menstruation and Ovulation .....</b>	<b>88</b>
<b>6. Puberty and Adolescent Gynaecology .....</b>	<b>111</b>
<b>7. Conception .....</b>	<b>120</b>
<b>8. Spontaneous Abortions (Including Recurrent Loss) .....</b>	<b>131</b>
<b>9. Ectopic Pregnancy .....</b>	<b>142</b>
<b>10. Gestational Trophoblastic Disease .....</b>	<b>160</b>
<b>11. Breast Function and its Disorders .....</b>	<b>174</b>
<b>12. Development of the Urogenital System .....</b>	<b>189</b>
<b>13. Malformations and Maldevelopments of the Genital Tract .....</b>	<b>196</b>
<b>14. Sex Determination, Asexuality and Intersexuality .....</b>	<b>219</b>
<b>15. Injuries .....</b>	<b>251</b>
<b>16. Pelvic Organ Prolapse .....</b>	<b>275</b>
<b>17. Other Displacements of the Uterus .....</b>	<b>293</b>
<b>18. Torsion of Pelvic Organs .....</b>	<b>304</b>
<b>19. Infections Including STD .....</b>	<b>308</b>
<b>20. Infections as They Affect Individual Organs .....</b>	<b>333</b>
<b>21. Genital Tuberculosis .....</b>	<b>361</b>
<b>22. Endometriosis and Allied States .....</b>	<b>365</b>
<b>23. Polycystic Ovary Syndrome .....</b>	<b>384</b>
<b>24. Hirsutism .....</b>	<b>394</b>
<b>25. Epithelial Abnormalities of the Genital Tract .....</b>	<b>400</b>

26. Genital Cancers .....	427
27. Tumours of the Vulva .....	440
28. Tumours of the Vagina .....	456
29. Tumours of the Cervix Uteri .....	464
30. Tumours of the Corpus Uteri .....	487
31. Tumours of the Fallopian Tubes .....	517
32. Tumours of the Pelvic Ligaments .....	521
33. Tumours of the Ovary .....	524
34. Chemotherapy in Gynaecological Malignancies .....	561
35. Radiotherapy in Gynaecological Malignancies .....	568
36. Immunotherapy in Obstetrics and Gynaecology .....	573
37. Amenorrhoea, Hypomenorrhoea and Oligomenorrhoea .....	579
38. Abnormal and Excessive Uterine Bleeding .....	598
39. Dysmenorrhoea .....	617
40. Premenstrual Syndrome and Other Menstrual Phenomena .....	627
41. Hormone Therapy in Gynaecology .....	637
42. Vaginal Discharge .....	656
43. Pruritus Vulvae and Vulvodynia .....	662
44. Low Backache and Chronic Pelvic Pain .....	676
45. Problems of Sex and Marriage .....	681
46. Infertility and Assisted Reproductive Technology .....	699
47. Instruments and Gynaecological Procedures .....	731
48. Ultrasonography in Gynaecology .....	741
49. Endoscopic Surgery in Gynaecology .....	767
50. Contraception .....	784
51. Sterilisation and Termination of Pregnancy .....	824
52. Urinary Problems .....	839
53. Menopause .....	862
54. Hysterectomy and its Aftermath .....	884
55. Conditions of the Lower Intestinal Tract .....	890
56. Preoperative and Postoperative Management: Postoperative Complications .....	899
57. Nutrition in Women from Adolescence to Menopause .....	925
58. Exercise and Physiotherapy in Gynaecology .....	946
<i>Index</i> .....	953

# CHAPTER 1

## A Clinical Approach to Gynaecology

Psychosomatic and Sociological Aspects of Gynaecology	2
Clinical Methods	2
Special Tests and Accessory Aids to Diagnosis	12

*"Mulier est hominis confusio,-  
Madame, the sentence of  
this Latin is,  
'Woman is mannes joye  
and all his bits'."*

- CHAUCER

Gynaecology (from the Greek *gyne*, woman, and *logos*, discourse) is the study of woman but usage restricts it mainly to the study of the female organs of reproduction and their diseases. This is convenient although the dividing line between gynaecology and other branches of medicine is ill defined, and varies from time to time and from clinic to clinic according to advances in knowledge, to custom and to local working conditions. At one time, the breasts were wholly within the domain of the gynaecologist but now the general surgeon deals with certain breast disorders, and the gynaecologist and obstetrician with the others. The genital tract is so closely linked, embryologically and anatomically, with the urinary tract and the large bowel that certain conditions of the urethra, bladder and rectum come to a greater or lesser extent within the province of the gynaecologist. The whole endocrine system is concerned with the control of genital functions while the psyche and sex are inseparable.

It may be added that, according to definition, obstetrics (the study of childbirth and its disorders) is merely one aspect of gynaecology and, in practice, the two cannot properly be separated.

These points merely serve to emphasise that it is impossible to consider the reproductive system except in relation to the remainder of the body, and that it is necessary to interpret gynaecology in the widest sense. Woman is more than just a container for a uterus and ovaries. The development of the highly specialised gynaecological surgeon improves operative technique but may also engender a narrow and harmful outlook. Such a specialist can become a craftsman first and a doctor second. The woman who seeks advice for discomforts related to the genital organs is not usually in need of an operation: her need is understanding - understanding the woman as a whole - her outlook, her achievements and failures, her domestic and social, as well as sexual, problems.

The care of the whole woman will be threatened by the development of subspecialties such as gynaecological endocrinology, foetal medicine, gynaecological oncology and gynaecological urology, unless proper basic training in obstetrics and gynaecology remains a prerequisite to subspecialisation. These developments are justified only in a few centres, to promote growth of knowledge and expertise; otherwise they deprive the woman of the person she can look to for help at any time, one whom she knows has a personal interest in, and responsibility for, her welfare.

Although covering all aspects of the physiology of the female genital tract, gynaecology is basically a clinical discipline and gynaecologists need to be primarily clinicians.

### PSYCHOSOMATIC AND SOCIOLOGICAL ASPECTS OF GYNAECOLOGY

Environment can cause or aggravate physical and mental ill health; the psyche influences the development of organic disease in all parts of the body; illness begets anxiety and this in turn begets illness; the reactions of doctor, relatives and friends to illness can determine recovery or chronic invalidism. These are not new discoveries but are as old as the practice of medicine. Psychosomatic medicine and social medicine are merely new names for old arts which are practised almost automatically by the good doctor and which find an important place in gynaecology. Thus, menstruation can be inhibited for many months by a subconscious need to attract attention, by a desire for pregnancy and by a change in occupation or in living conditions. On the other hand, menstruation may be precipitated by excitement and can become regularly excessive in response to nervous tension and domestic disharmony. A woman may develop pelvic symptoms to escape the advances of her husband. Painful menstruation, painful coitus and the like frequently have fear, resentment or guilt over genital functions as their basis - inculcated possibly by impressions and experiences gained during childhood. Obesity is much more likely to be a manifestation of an anxiety state or bad habit than evidence of endocrine disturbance. Many women, when worried, find solace in eating and drinking; if they are sleepless, they have longer hours in which to solace themselves.

A woman faced with unwanted responsibilities, or with any distasteful situation, may try to escape by blaming her genital organs about which there remains an air of mystery which secures for her the sympathy of other women and of the oversolicitous husband. A gynaecologist must be a psychologist although not necessarily a trained psychiatrist. If the part played by emotional and environmental factors in pelvic disease is recognised, only experience and wisdom are required to elicit them. The majority of women are unconscious of these factors in their illness and, when made aware of them by sympathetic explanation, encouragement and tact, can adjust themselves to ensure a cure. There are a few, however, who deliberately set out to deceive and

go to such lengths to achieve their objective that they are not easily found out. Take for example the following rare case:

A married woman aged 30 years, with two children, complained of recurrent and persistent vaginal bleeding which failed to respond to several lines of treatment. Ultimately her uterus was removed, whereupon the bleeding continued and was found to be coming from vaginal ulcers which refused to heal even when repeatedly excised. It was then proved that she deliberately injured the vagina to make it bleed.

Rather than confining psychosomatic gynaecology to a single chapter, the aim in this book is to include it wherever it belongs, in the hope of placing it in its proper context. If the psychological aspects of gynaecology suffered from neglect in the past there is now some danger of their being exaggerated. *In clinical practice it should be made a rule never to diagnose neurosis or a psychogenic basis for symptoms until organic disease is excluded for certain.*

### CLINICAL METHODS

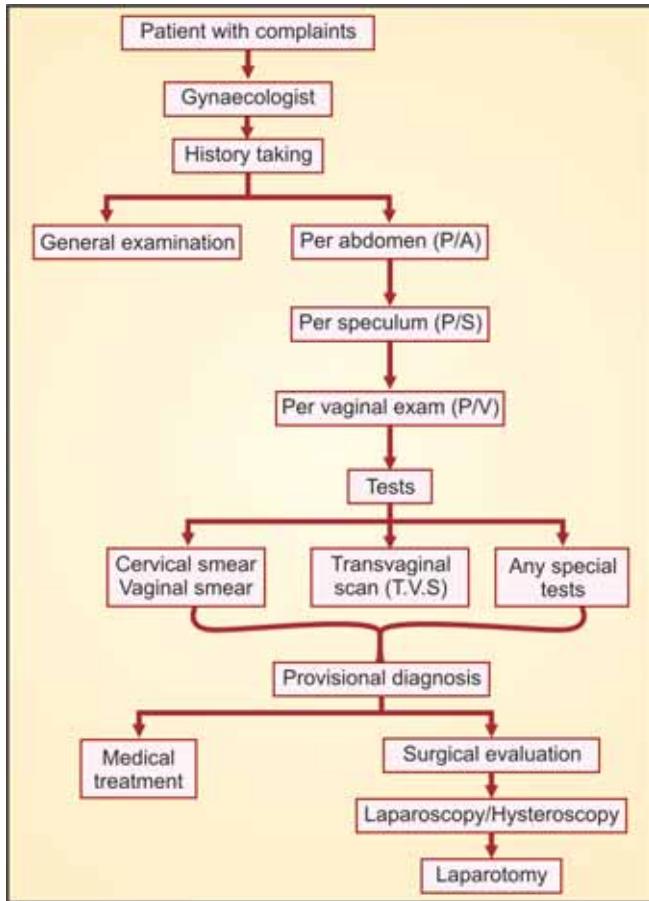
The handling and examination of the patient can only be properly taught and learned in the consulting room (office) and at the bedside, and there is more than one way of doing them well. A systematic account of clinical methods is as wearisome to the writer as it is unprofitable to the reader. In this chapter, it is proposed to comment only on certain general principles and to offer suggestions for overcoming common difficulties.

The diagnosis of the cause of the patient's complaints depends on a process of detection. Some clues are worthless and misleading, others are small but important. The good diagnostician is one who quickly realises what is significant and what is not, one who will not dismiss evidence, bizarre though it may appear, if it does not fit in with preconceived ideas. Clinical intuition is no more than the capacity to take intelligent notice (sometimes almost subconsciously) of small points (Flow chart 1.1).

### History

It is essential for the physician to communicate with a patient in a manner that allows her to continue to seek appropriate medical attention. It is necessary that a doctor listens to a patient completely and if there is a good ear to listen the diagnosis will be made easy. Not only the words used, but also the patterns of speech, the manner

**Flow chart 1.1:** An approach to a case with gynaecological problems



in which the words are delivered, even body language and eye contact, are important aspects of the patient-physician interaction.

The most important evidence is always provided by the history which the patient or her relatives can give-if allowed to do so. The diagnosis can nearly always be made or reduced to one of two or three possibilities based on the history, without any physical examination. Indeed, it can often be made by telephone.

Physical signs are less reliable and should mainly be used as confirmatory evidence. It is good practice never to examine the patient without having a provisional diagnosis in mind.

The previous medical history, family history and the account of symptoms as given by the woman can be boring, but scrupulous attention to them saves time,

trouble, special investigations and mistakes. She appreciates the opportunity to tell her story and, amongst irrelevances, invariably gives vital clues. Moreover, many irrelevances can be avoided by skilful guidance and by the occasional leading question.

A garrulous old woman aged 80 years was admitted to hospital as an emergency case with the history of a sudden onset of lower abdominal pain following a fall on getting out of bed. A few leading questions did not reveal typical features of any of the ordinary abdominal crises and, as the physical signs were not remarkable, she was kept under observation for 10 days during which time her discomfort subsided. She then appeared well and was prepared for discharge home. On the day the patient was due to leave hospital, as a final check, she was referred for the opinion of a gynaecologist. She was then, for the first time, allowed to tell her own story, from which it became clear that the sequence of events was (1) pain, (2) getting out of bed, (3) faintness causing her to fall, (4) unconsciousness on the floor for a few minutes, (5) residual abdominal pain and tenderness. All that remained necessary was to recognise a faint bruise around the umbilicus as 'Cullen's sign', and the picture of intraperitoneal haemorrhage was sufficiently complete to justify laparotomy. This revealed the cause to be a small and previously non-palpable sarcoma in the fundus of the uterus.

Successful interrogation requires an inquisitive outlook. Why has this woman come to see me today and not 6 months ago? Why has she not had children during 3 years of marriage? What was the illness which confined her to bed for 3 months in childhood and what were its symptoms and treatment? At what time in pregnancy did the two abortions occur? How long did she breastfeed the last baby? Did she suffer fever after any of the pregnancies? How old is her husband? Is she an only child? Have her aunts got hairy faces? What operation was carried out 5 years ago? What were her symptoms at the time and what was she told? Has she a home of her own? Does she go out to work and who looks after the children while she does? Why is she worrying about a trivial symptom or is it her mother worrying on her behalf? Is she afraid of cancer or of a sexually transmitted disease?

History taking also requires tact, for it is concerned with details of what some women regard as highly embarrassing topics. It calls for privacy, kindness, courtesy and a deferment of the more personal questions

until confidence is established. Previous illness and confinements are usually safe grounds, although caution is necessary if a baby has been lost. A woman may find it easier to talk about menstruation than about discharge, while marital and domestic problems should come last. A matter-of-fact and coldly scientific attitude is the one most likely to encourage the patient to discuss intimate matters without embarrassment. Attention to dress, avoidance of jokes, formal behaviour and concentration on the patient and her problems are especially important to maintain the right atmosphere in a teaching clinic.

Importance should be given to the Patient-Physician Relationship. One needs to listen more and talk less. Encourage the pursuit of topics important to patients. It is necessary to realise that one should minimise controlling speech habits such as interrupting, issuing commands, and lecturing. Care should be taken to understand discomfort of certain issues and become aware of discomfort in an interview, recognise when it originates in an attempt by the physician to take control, and redirect that attempt. The confidence one gives by assuring patients that they have the opportunity to discuss their problem fully is very important. Sometimes all that is necessary is to be there as a compassionate human being. If clinical findings or confirmatory testing strongly suggest a serious condition (e.g., malignancy), the gravity and urgency of this situation must be conveyed in a manner that does not unduly alarm or frighten the individual. Honest answers should be provided to any specific questions the patient may want to discuss.

Often during the course of examination, some fact of which the patient is ashamed comes to light. Perhaps she is pregnant, or has been pregnant, or has had a sexually transmitted disease. Such confidential disclosures are to be received impassively and naturally, without sign of approval or disapproval, and the patient should not see that any record is made of them.

## SYMPTOMS

### Trivial Symptoms

Whenever the symptom appears inadequate or atypical, suspect that it is a cloak for another worry. The recently married woman who complains of longstanding dysmenorrhoea is probably suffering from painful coitus. The woman without children after several years of

marriage is often complaining of infertility whatever other symptoms she presents. Vague pains or insignificant discharge may denote cancer phobia.

### Pain

#### *Exact Site and Radiation*

Ovarian and tubal pain is felt *low* in the abdomen, usually immediately above the inguinal ligament. Pain of uterine origin is diffuse and hypogastric in site, often referred to the inner aspects of the thighs but not extending below the knees. Backache of pelvic origin is in the midline, never higher than SI. It is not accompanied by local tenderness. It is easy to ask the patient to indicate the site of pain but failure to do so is common.

#### *Nature of Onset and Duration*

These again are elementary matters, the neglect of which leads to errors. The pain present for 10 years can hardly be attributed to an event that occurred two years ago. The cervical laceration sustained during childbirth, or a retroversion following pregnancy, cannot be responsible for backache which commenced during the pregnancy. The patient should have a clear recollection of the circumstances under which a *sudden* onset of pain occurred.

#### *Character*

A pain which the patient describes as 'burning' or 'throbbing' rarely has an organic basis. 'Excruciating' is also an adjective which raises doubts as to the genuineness of the discomfort.

#### *Intensity*

This is best measured by the effect of the pain on sleep and work. If it does not cause wakefulness it is either caused by a lesion which is relieved by rest or is of little consequence. Severe pain is almost always reflected in the patient's manner and demeanour. The woman of healthy appearance who describes her agony with a smile, and whose attention is easily distracted from it, is overstating her case.

#### *Relationships*

In the patient complaining of pain, the clinician should try and establish its relationship to the following:

- **Menstruation:** Women may try to link discomfort with menstruation and persuade themselves, if not the observer, that an association exists. There is always a lowering of pain threshold before and during menstruation so that even toothache feels worse at that time. Nearly every condition affecting the lower part of the body exhibits a premenstrual exacerbation, e.g. irritable bowel syndrome, sacroiliac and lumbosacral strain. Care is therefore necessary to ensure that a pain is truly associated with menstruation and, if it is, to know its exact relationship to the occurrence of the flow.
- Coitus
- Micturition
- Defecation
- Eating
- **Posture and movement:** Recognition of the relationship with exercise and rest prevents many types of backache being attributed to a pelvic lesion. In fact, a backache which worsens by the evening is most often the result of strain imposed by a lax protuberant abdominal wall and the consequent compensatory lumbar lordosis.

**Menstrual Function**

*Menarche and Standard Menstrual Habit*

It is necessary to know the age of the menarche and the cycle which is normal for the particular individual. Knowledge of the latter provides a standard with which to compare symptoms. Women are often treated for 'heavy periods' without it being recognised that their menstrual function has never changed.

*Menstrual Symptoms*

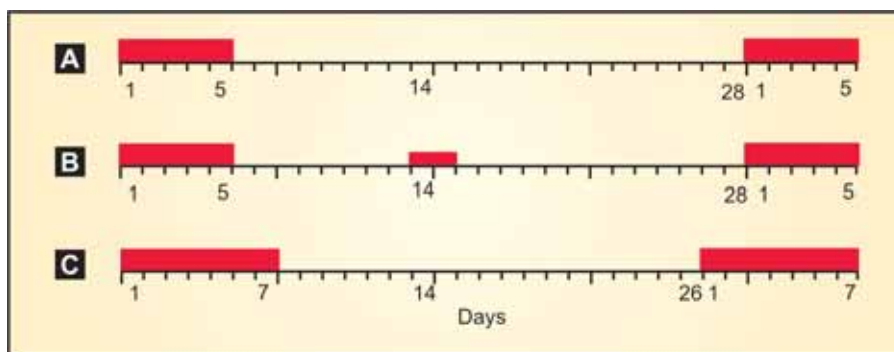
Patients unwittingly mislead themselves and the observer about the cycle. They say they menstruate 'twice a month' when periods begin on the second and twenty-eighth day of the same month (that is, a 26-day cycle). They say they menstruate every 3 weeks when they mean that they are *free* from bleeding for 3 weeks (Fig. 1.1). Many keep no record of the dates of menstruation.

When there is no urgency, ask the patient to keep a menstrual calendar for 3 months; she is often surprised at the regularity which this reveals. The amount of bleeding can be judged by the number of sanitary pads or tampons used, by interference with work or other pursuits, and by the presence of anaemia. In difficult and doubtful cases, the woman should be kept under observation throughout a certain period.

Abnormal menstrual cycles deserve close analysis. It is not enough to know whether the loss is profuse or slight; its exact duration and periodicity must be determined.

*Last Menstrual Period*

Knowledge of the date of the first day of the last menstrual period (and in many cases the date of the preceding one) is vital from the standpoints of diagnosis and treatment. The woman may say she does not know, or may use some vague expression such as '2 weeks ago' but, with encouragement and help, can nearly always calculate the exact day. One of the reasons for knowing this is that *every woman between the ages of 15 and 50 years should be regarded as being pregnant until proved otherwise*. Failure to relate symptoms to the time in the menstrual



**Fig. 1.1:** Examples of misinterpretation of the menstrual cycle: (A) This represents a normal situation in which bleeding occurs for 5 days every 28 days, (B) A normal cycle with a short loss at the time of ovulation, described by the patient as menstruation every 2 weeks, (C) An essentially normal cycle (7/26) described by the patient as having two periods in one month or bleeding every 19 days

cycle explains why ovulation pain, corpus luteum haematoma, ectopic pregnancy and endometriosis are misdiagnosed as appendicitis.

When there is dysmenorrhoea (painful menses) the history should be in more details as follows:

As there are two types of Dysmenorrhoea (spasmodic and congestive) a careful history is needed to differentiate the same. Spasmodic or the Primary dysmenorrhoea has no obvious cause and is seen on the Day 1 or 2 of the menstruation, whereas congestive or the secondary dysmenorrhoea is due to some pathology in the gynaecological organs and the pain may be either premenstrual, menstrual or post-menstrual in nature. When a girl or a woman gets the secondary type (congestive) of dysmenorrhoea it is necessary to ask whether the pain is relieved on menstruation and if so the reason may be pelvic inflammatory disease (PID), whereas if the pain is more after menstruation it is usually due to endometriosis (ectopic menstruation). Menstrual type of dysmenorrhoea is usually due to fibroid of uterus (benign tumours of uterus) or adenomyosis (ectopic endometrium in the myometrium). Triple dysmenorrhoea (premenstrual, menstrual and post menstrual) is typical of endometriosis.

#### *Associated Symptoms*

In condition like endometriosis a girl or woman may have all of the following symptoms or none of them or some of them.

It is important to remember the 5 'D's':

- Dysmenorrhoea
- Disorders of menstruation
- Dysparunia (painful coitus)
- Dyschezia (pain during passing stools)
- Dull aching pain abdomen (due to distortion of anatomy)

And Infertility will be the additional problem in cases of endometriosis.

## PHYSICAL EXAMINATION

### General

A full general examination is as important in gynaecology as in any other branch of medicine and more important than in some others. Note the general appearance and behaviour of the patient. Does she show evidence of anaemia, dehydration, wasting, increasing

weight or hirsutism? The neck may reveal enlargement of the thyroid gland or of lymph nodes. Disease of the heart and lungs must be excluded and in certain conditions chest radiography may be required. Examination of the mouth, hands, arms, legs and feet may precede or follow examination of the abdomen.

### Breasts

While examining the heart and lungs, the breasts can be inspected to assess their development, and to exclude those changes indicative of early pregnancy without the patient realising that pregnancy is suspected. This is particularly true for the young unmarried girl. In all women and especially in those aged 30 years and more, the breasts should be palpated routinely to exclude tumour formation. Galactorrhoea should be looked for in women who are infertile and in those who have oligomenorrhoea.

### Abdomen

It is necessary to understand that by a proper examination with the patient being comfortable, we will be able to get the right findings which will give the path to the right diagnosis. With the patient in the supine position, an attempt should be made to have the patient relax as much as possible. Her head should be leaned back and supported gently by a pillow so that she does not tense her abdominal muscles.

The abdomen should be inspected for signs of an intra-abdominal mass, organomegaly, or distention that would, for example, suggest ascites or intestinal obstruction. Initial palpation of the abdomen is performed to evaluate the size and configuration of the liver, spleen, and other abdominal contents. Evidence of fullness or mass effect should be noted. This is particularly important in evaluating patients who may have a pelvic mass and in determining the extent of omental involvement, for example, with metastatic ovarian cancer. A fullness in the upper abdomen could be consistent with an "omental cake." All quadrants should be carefully palpated for any evidence of mass, firmness, irregularity, or distention. A systematic approach should be used (e.g., clockwise, starting in the right upper quadrant). Percussion should be used to measure the dimensions of the liver. The patient should be asked to inhale and exhale during palpation of the edge of the liver.



Omission to carry out an abdominal examination *before* a pelvic one results in many errors. The following are some points deserving emphasis:

- No one is, or should be, better than the gynaecologist at palpation, for she/he is dependent on a highly developed and regularly used sense of touch for work in the antenatal clinic and in the delivery room, and for pelvic examination in general.
- The lighter the palpation and the more the hand is kept on the flat, the easier it is to define tumours.
- Every tumour in the lower abdomen should be suspected as being a full bladder and this condition can sometimes only be excluded for certain by passing a catheter. Otherwise, the commonest mass is a pregnant uterus.
- Percussion of the abdomen can be even more valuable than palpation in the diagnosis of tumour, in distinguishing it from ascites and in deciding whether it is intraperitoneal or retroperitoneal. Except when a loop of bowel is adherent, all tumours arising from the pelvic organs are uniformly dull to percussion. A retroperitoneal tumour (including one of renal origin) almost always has one or more loops of bowel in front which show by resonance (Fig. 1.2).

Pseudocyesis and phantom tumours provide no problem to the doctor who percusses.

Whenever an abdominal tumour is found, examine especially for ascites and enlargement of the liver.

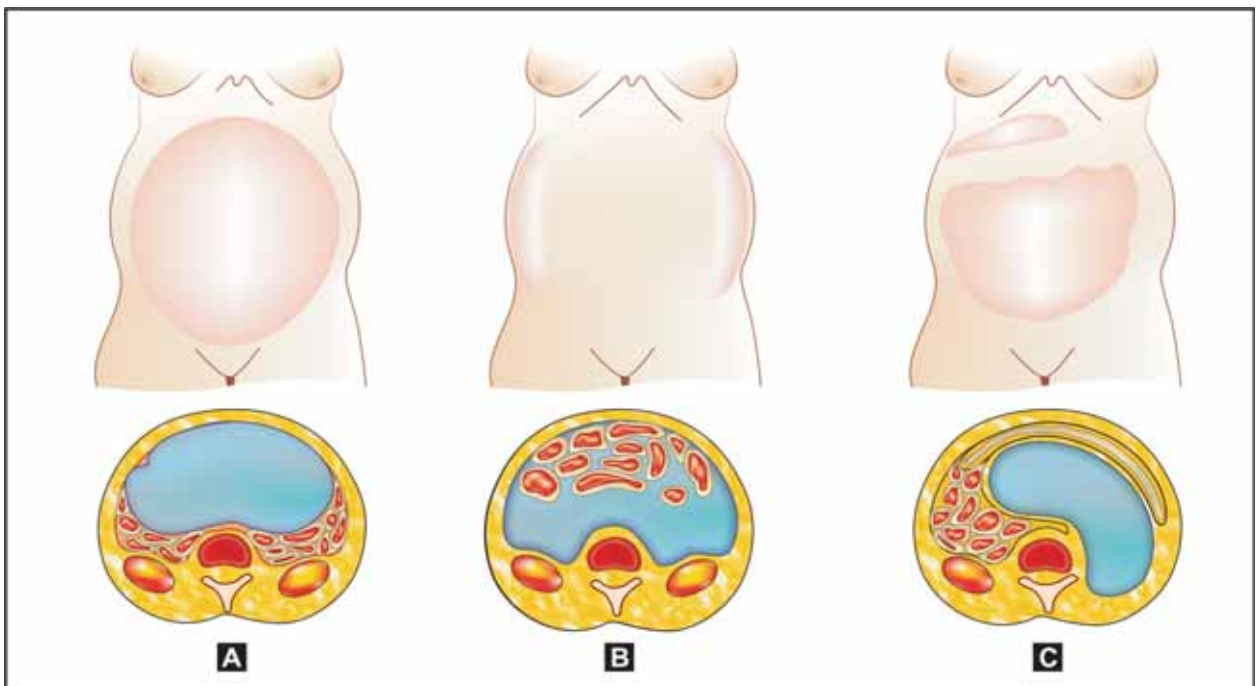
### Examination of a Mass Per Abdomen

#### Inspection

Note the abdomen for the shape or distension, dilated Veins.

#### On Palpation

Note the size, shape, consistency, margins, mobility, unilateral or bilateral. It is important to differentiate between ovarian tumours (benign) from fibroid uterus. When a suprapubic mass is palpable, it is necessary to find out whether we could put our hands below the lower border or not. This is called as getting below the mass. If so the diagnosis is a benign ovarian tumour since the mass is pushed up because of the long pedicle an ovarian tumour has. If we cannot get below the lower border then the diagnosis is usually fibroid of uterus and the mass is described as 'arising from the pelvis'. However if the problem is of malignant ovarian tumour then



**Fig. 1.2:** Percussion of the abdomen in the diagnosis of tumours. Dullness is indicated by shaded areas, resonance is shown in white, (A) An ovarian or uterine tumour, (B) Ascites, (C) A retroperitoneal tumour, a large hydronephrosis, for example

because of the spread of the disease the mass will be of variegated consistency, margins not clear, fixed or restricted mobility, and there may be presence of ascitis too. However all the malignant tumours do not have ascitis as only epithelial ovarian malignancy produces ascitis.

*Percussion:* Fluid thrill and shifting dullness should be tested for to rule out ascitis.

### Pelvic Examination

Pelvic examination is the last part of a gynaecological examination, its main purpose being to confirm a diagnosis already made or suspected from the history and symptoms. It should be repeated from time to time when an illness is long lasting, for the situation may change. One of the common traps is illustrated by the following case.

A young single woman was attended on and off for many years by an excellent general practitioner because she had irregular and infrequent periods. At the original assessment no disease was found, so she was properly treated on general lines and assured that her symptom was of no consequence. At the age of 23 years she was still menstruating every 3-4 months and had become anxious to know if her fertility would be affected in the event of her marrying. Without further examination the doctor assumed that the problem was the same as it had always been. At the gynaecological clinic, it was singularly easy to reassure the young woman about her fertility because she was already 14 weeks' pregnant.

### Prerequisites

- Presence of a third party, preferably a female nurse or relative, if the examiner is a male.
- Consent of the patient or, if she is young and unmarried, of her parent or guardian. In the case of a specialist gynaecologist, it is generally accepted that the patient's attendance implies consent to a pelvic examination.
- The patient's bladder must be empty.
- The rectum and pelvic colon too should preferably be empty. If loaded, it may be wise to ask the patient to return after the bowel has been cleared by a laxative.
- A good light which is well situated.

### Vaginal Examination

Vaginal examination is usually more informative than rectal examination and is possible in most women. If the patient is virginal, the opening in the hymen may be wide enough to allow a one-finger or narrow speculum examination without pain or injury, especially if she is in the habit of using a tampon to control the menstrual discharge. A decision about attempting a vaginal examination in any case must be based on a previous assessment of the circumstances and the likely reaction of a given patient. In this connection, it is necessary to recognise the customs and religious beliefs in different countries. In the East and Middle East, for example, vaginal examination of the unmarried woman is generally never attempted for it may prejudice her prospects of marriage. Unless a bride can prove her virginity by an intact and unstretched hymen, the marriage may be annulled. For such reasons, it is not unknown for parents to refuse to allow their daughters to be treated for imperforate hymen causing haemato-colpos. Whenever a tentative approach makes it clear that the patient is averse to the examination and that she is unlikely to cooperate, there should be no attempt at persuasion. If rectal examination coupled with ultrasonography does not supply all the necessary information, vaginal examination under anaesthesia is indicated. Each part of the genital tract should be examined in logical sequence - vulva, vagina, cervix, body of uterus, adnexa, pouch of Douglas.

Gloves and instruments, if not disposable, should be sterilised by autoclaving before reuse. Washing and boiling offer inadequate protection against the real risk of transferring *Trichomonas*, *Candida*, *Chlamydia*, HIV and other organisms from one woman to another. All instruments should be dipped in bleach solution before autoclaving in order to kill HIV.

The lubricant should be non-greasy. A water-soluble jelly is the best and, failing that, cetrimide solution. Antiseptic creams often cause local reactions and lanolin is difficult to remove. Any discharge or lubricant left on the vulva at the end of the examination should be swabbed away for the patient's comfort.

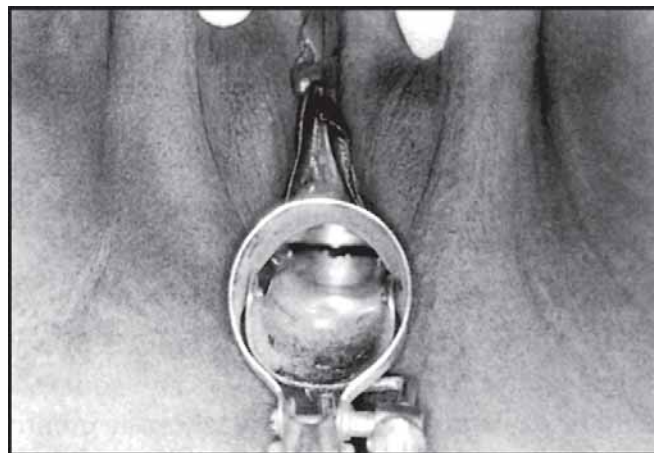
Inspection should precede palpation. Inspection of the vulva, vagina and cervix includes testing for prolapse. Speculum examination of the vagina and cervix should usually precede bimanual examination for the following

reasons: vaginal discharge can be seen and removed for examination before it is contaminated with the lubricant; the cellular debris from the cervix and uterus is undisturbed and can be obtained for cytological study; and bimanual examination may make some lesions of the vagina and cervix bleed. Inspection thereafter is difficult, if not impossible. Although it is not easy to choose the right-sized speculum until the capacity of the vagina is judged by palpation, this difficulty can usually be overcome by careful appraisal of the introitus.

A Sims' or bivalve speculum (Fig. 1.3) should *not* be inserted with its blade in line with the cleft of the vulva and then rotated in the vagina. These instruments are designed for direct application after separation of the labia with the fingers of the opposite hand. The vagina is, in any case, wider from side to side than from front to back.

For palpation, first insert one finger into the vagina; insert the second finger only when the patient relaxes the muscles around the vagina and when it is clear that a two-finger examination is possible without causing pain. Avoid the sensitive vestibule and urethral orifice and remember that the vagina slopes upwards and *backwards*. Insert and withdraw fingers slowly.

The secret of bimanual examination is to use the abdominal hand more than the vaginal fingers. It is the former which must bring the various organs within comfortable reach. The beginner always thinks that shortness of the fingers accounts for inaptitude whereas it is failure to use the abdominal hand correctly. To feel the uterus, the vaginal fingers should move the cervix as far backwards as possible to rotate the fundus



**Fig. 1.3:** The speculum is introduced directly in the transverse axis of the vagina (see text)

downwards and forwards. The abdominal hand is then placed just below the umbilicus (not suprapubically) and gradually moved lower until the fundus is caught and pressed against the fingers in the anterior fornix. The uterus which is not felt is lying *above* and behind the abdominal hand.

The points to be determined in regard to the cervix and the uterus are the size, shape, position, mobility, consistency and tenderness caused by pressure or movement. The *normal* uterus is tender when squeezed between the two hands. The position and direction of the cervix are the guides to the body of the uterus; for this reason, mere inspection of the cervix usually indicates whether the uterus is anteverted or retroverted.

#### *How do we describe the size of a uterus?*

A bulky uterus (corresponding to 6 weeks pregnant size) is just bigger than normal. When the uterus is filling all the fornices it is corresponding to 12 weeks pregnant size uterus. When the fornices are not full the size can be less than 12 weeks size. In between the size could be between 8 to 10 weeks size.

The following points are noted: Size of the uterus, anteverted or retroverted, mobile uterus, restricted mobility or fixed uterus. The adnexa is palpated for any masses or tenderness. If there is a mass felt its relation to the uterus is noted like whether the mass is felt separate to the uterus or is it felt continuous with the uterus. When the mass is felt separate to the uterus the origin of the mass is from the adnexa or broad ligament like the ovarian mass, broad ligament masses; whereas if the mass is continuous with the uterus it is arising from the uterus like a fibroid of the uterus. However in conditions like Endometriosis and Pelvic inflammatory diseases the adnexa may have a mass which is fixed and tender.

#### *Rectal Examination*

Rectal examination too can be assisted by placing the other hand on the lower abdomen to make it a bimanual procedure. Palpation of the cervix, uterus and adnexa is more difficult than by the vaginal route, and pressure on the cervix through the rectal wall nearly always causes pain.

Rectal examination is useful when vaginal examination is impossible and has a special place in the pelvic investigation of babies and children, especially if ultrasound is not possible. It is also a useful adjunct to

vaginal examination and is the best approach for feeling the uterosacral ligaments, pouch of Douglas and the outer parts of the broad ligaments; it is, therefore used for assessing the extent of a growth arising in the cervix.

#### *Combined Rectal and Vaginal Palpation*

It is extremely helpful to insert the index finger into the vagina and the middle finger into the rectum. This combined method has a special value in determining whether a lesion is situated within the bowel or between the bowel and the genital tract.

#### *The Findings*

The student new to gynaecology is often depressed at being unable to palpate the uterus and adnexa. It should be explained that it usually takes one month's work in a clinic before one can expect to feel the uterus bimanually in a reasonably cooperative unanaesthetised patient. In the more difficult case the uterus can be felt only if the patient is anaesthetised, and not always even then. The expert gynaecologist who confidently states that the uterus is normal in all respects sometimes does so without actually defining it. If honest, he or she will admit that often the findings are deduced by noting the position and mobility of the cervix, and by knowing that the uterus would be felt if it were enlarged.

Normal tubes are *never* palpable, even in the anaesthetised patient. Palpation of the ovaries is largely a matter of chance but if they are not felt, the gynaecologist can be reasonably certain they are not enlarged. It may be added that even an expert at bimanual examination remains expert only so long as he or she is in regular practice; even one month's holiday reduces one's skill in the following week.

A swelling which lies posterior to the vagina is nearly always caused by the rectal contents. A swelling in the left side of the pelvis should be regarded as originating in the bowel until proved to the contrary.

#### *The Position of the Patient for Pelvic Examination*

There are several possible examination positions and all have a place in practice. Each has certain merits and strict adherence to one position is limiting.

**Full dorsal position (Figs 1.4 and 1.8A):** This is the most commonly employed position. It is the best for inspection of the vulva and for bimanual palpation of the uterus



**Fig 1.4:** Bimanual examination in the full dorsal position. Keeping the knees covered makes the patient feel less exposed



**Fig. 1.5:** Sims' semi-prone position

and adnexa. It is not as good as the lateral position for inspecting the vaginal walls. Moreover, it can be embarrassing for the patient, especially in a teaching clinic. To maintain this position, nothing more than a firm couch is necessary, the examiner standing on the right side. The woman feels much less exposed if the thighs and knees are kept partly covered. Some gynaecologists prefer a short couch with foot rests, and they then stand directly in front of the patient.

**Sims' semi-prone position (Fig. 1.5):** This position was devised by Marion Sims for operations on vesicovaginal fistulas. Used in conjunction with Sims' speculum it is good for inspecting the anterior vaginal wall and cervix because, when the introitus is opened, the vagina balloons with air. The patient finds this position least

embarrassing but movement is limited by the position of the left arm, and the abdomen is not easily accessible to the examiner's left hand. It is therefore rarely used, especially nowadays with the availability of sophisticated operating tables.

*Modified Sims' or Lateral Position (Fig. 1.6)*

Here the patient keeps her left arm in front and she lies more on her side. It causes little embarrassment and allows good inspection of the anus, perineum, posterior parts of the vulva, vagina and cervix. It may be used for demonstrating prolapse during coughing and straining, and for minor operations on the cervix of the unanaesthetised woman. Bimanual examination is possible but is generally not as satisfactory as in the dorsal position.

*Lithotomy Position (Fig. 1.7)*

This is usually used for vaginal operations and for examination under anaesthesia.

*Knee-Chest Position*

This allows the vagina to balloon with air, encourages the intestines to fall away from the pelvis and is ideal for visualising the cervix and anterior vaginal wall. The patient finds it objectionable, however, so it is rarely used. It was previously used for certain operations, such as the insertion of radium or caesium, repair of a vesicovaginal fistula and culdoscopy.

Bearing in mind the advantages and disadvantages, I make it a practice to examine the patient in the full

dorsal position. This allows inspection of the introitus, testing for prolapse, inspection of vagina and cervix and the taking of swabs and smears. After speculum examination, first one and then two fingers are inserted into the vagina and bimanual examination is conducted. Combined rectal and vaginal examination is done when required.

**How to Get the Patient to Relax**

Satisfactory pelvic examination depends on the cooperation of the patient; this in turn depends on the personality of the medical attendant, the gentle but firm laying of hands and a calculated gradual but confident approach. The examiner who does not hurt the patient learns most, even if he does not reach the furthest.

Despite care over these points, through nervousness, modesty and fear, some women find it difficult to relax the muscles of the abdomen and pelvic floor to allow bimanual examination. In these circumstances it is generally advised that the patient should flex the thighs on the abdomen and breathe deeply through the mouth, a procedure which is not always effective.

The best way to obtain relaxation of the abdominal muscles in the dorsal position is for the patient to arch her back (without assistance from attendants) and to support herself on her shoulders and feet (Fig. 1.8B). Strong action of the extensor muscles of the trunk ensures complete and automatic relaxation of the flexors. This method also helps with the insertion of a bivalve speculum in the dorsal position. More over, in this position the pelvis rotates to bring the uterus nearer to



Fig. 1.6: Lateral position



Fig. 1.7: Lithotomy position

the abdominal wall. Relaxation of the levators and other muscles around the vagina is secured by the patient deliberately abducting the thighs or by bearing down as in defaecation.

## SPECIAL TESTS AND ACCESSORY AIDS TO DIAGNOSIS

### Ancillary Services

With the ever-increasing number of laboratory tests and other investigations, the paramount value of ordinary clinical methods of diagnosis is in danger of being overlooked by the patient as well as by the medical attendant.

It is easier to fill in a request form for blood analysis or radiography than it is to take a full history. More reliance is placed on the shadow than on the substance, and on a laboratory report than on a clinical appraisal of the patient. Because the report is typewritten, many fail to recognise that it is no more than an opinion, and sometimes the opinion of a relatively inexperienced technician. It is useful, but often not any more than the opinion of the doctor at the bedside. Information about hormones can be obtained at much less expense and trouble by noticing their effect on the patient's own genital tract.

The biochemist, pathologist and radiologist are members of a team and each can contribute valuable evidence towards the solution of the problem but not

necessarily the complete answer. They should be used to fill in the gaps which remain *after* clinical assessment of the case.

### Cytology: Vaginal, Cervical, Uterine, Peritoneal

See Chapter 26.

### Colposcopy and Colpomicroscopy

See Chapter 25.

### Examination Under Anaesthesia

This is a valuable weapon when pelvic examination is difficult or impossible. Examination under anaesthesia is not the answer to all problems; it is frequently less satisfactory than examination without anaesthesia, can be frankly misleading and in certain conditions, e.g. ectopic pregnancy, is dangerous. Its great disadvantage is that the all-important sign of tenderness is lost.

Whenever this examination is carried out, anaesthesia must be sufficient to ensure complete relaxation of the abdominal muscles. To obtain the maximum information, the examination should generally include measurement of the cavity of the uterus and endometrial sampling. Hysteroscopy may sometimes give additional information (*see below*).

## ENDOMETRIAL SAMPLING PROCEDURES

### Endometrial Biopsy: Out-patient (Office) Curettage

The term endometrial biopsy is, by custom, applied to the incomplete diagnostic curettage carried out on the



**Figs 1.8A and B:** (A) Bimanual examination with the patient in the full dorsal position, (B) The attitude which the patient should adopt when examination is difficult. Use of the extensor muscles of the trunk ensures relaxation of the abdominal muscles; abduction of the thighs encourages relaxation of the pelvic floor. Tilting of the pelvis brings the pelvic organs within easier access of the abdominal hand

unanaesthetised woman. By means of a narrow biopsy curette, one or two strips of endometrium are obtained for histological study. This method is only used to determine the reactions of the endometrium to ovarian stimulation, or the presence of infective pathology, e.g. tuberculosis.

### Endometrial Aspiration

Endometrial aspiration is an extension of the biopsy. It allows more thorough evaluation and can be used to diagnose or exclude certain types of endometrial disease as an out-patient procedure, e.g. hyperplasia and tuberculosis, to determine the response of the endometrium to endogenous hormones and thereby assess ovarian function including ovulation. A special narrow cannula curette (Vabra) is inserted into the uterus and the endometrial tissue is extracted by electric suction. A 4 mm Karman-type cannula to which is attached a 20 ml syringe can be used instead with similar results. Suction is maintained for two minutes. This detaches the endometrium, following which the curette is gently rotated in all directions and the endometrium sucked out. Endometrial aspiration is essentially a diagnostic procedure and any material obtained by it must always be submitted to histological, and often to bacteriological, examination. Its indications are definite and it should never be carried out without a clear reason and for want of something better to do. Since dilatation of the cervix is not required, no anaesthesia, or at most local infiltration of the paracervical nerve plexuses, is necessary and the patient feels little discomfort. This procedure is now used instead of endometrial biopsy or curettage, except in select cases where curettage is done for therapeutic indications. Endometrial aspiration coupled with endocervical curettage can be used instead of fractional curettage in women with postmenopausal bleeding to diagnose malignancy in the uterus or endocervix. While a positive result is conclusive, a negative result could be falsely negative and such cases may require curettage or hysteroscopy.

### Curettage

Curettage may also be used to remove products of conception from the uterus, intrauterine polyps from the uterus or to discover disease of the endometrium.

Sometimes curettage may be therapeutic as in the case of dysfunctional uterine bleeding and prolonged

menstrual flow consequent to the irregular shedding of the endometrium.

In fractional curettage, the endocervical canal is curetted first and the sample set aside for histopathological examination. Next, the sound is passed gently into the uterine cavity to assess the direction and length, the cervix dilated gradually and the uterine body curetted thoroughly. The entire specimen from the body of the uterus forms the second sample. Fractional curettage is used for the diagnosis and localisation of malignancy in the uterine corpus or cervix.

All curettage procedures require some form of anaesthesia. They also carry a higher risk of complications such as perforation and injury to the cervical os and, therefore, aspiration procedures are generally preferred.

### Culdocentesis and Culdotomy

Culdocentesis is a procedure where in the needle is put through the posterior fornix into the pouch of Douglas and Culdotomy is a procedure where a transverse incision is put in the posterior fornix. However, culdocentesis was done for diagnosis of ruptured ectopic pregnancy or pelvic abscess but is no more done as there are better diagnostic modalities. Colpotomy is rarely done in cases of pelvic abscess drainage.

### Tubal Patency Tests

The commonly used tests are: (a) Hysterosalpinogram (b) Sonosalpingogram and (c) Laparoscopy chromotubation. The passage of carbon dioxide through the uterus and tubes was used to determine tubal patency in cases of infertility. As a diagnostic procedure, its results are so unreliable that it has been abandoned in most clinics where other methods for testing tubal patency are available. (*See also* Chapter on Infertility).

### Hysterosalpingography

Radiography of the interior of the uterus and tubes is especially useful in the diagnosis of tubal obstruction including hydrosalpinx, peritubal and intrapelvic adhesions, malformation of the uterus, small intracavitary tumours causing dysmenorrhoea and menorrhagia, and a defective internal cervical os causing abortion or premature labour.

Hysterosalpingography is valuable in the diagnosis of tubal disease such as tuberculosis. However, in the presence of active disease, it can lead to dissemination or activation of the disease and prove dangerous.

### Ultrasonography

Ultrasonography or sonar (sound navigation and ranging) was originally used to detect submarines by means of ultrasonic echo sounding. Highly sophisticated apparatus working on this principle is now the most valuable diagnostic tool in a wide range of obstetrical and gynaecological conditions. Ultra-sound waves of very high frequency (3.5-5 MHz) generated by passing electric current through a piezoelectric crystal are passed through the abdominal wall which has been smeared with jelly to secure acoustic coupling. Solid tissues reflect the ultrasound beam while liquids allow it to pass through. The echoes, which are reflected back to the crystal, are converted to electrical energy. The images thus vary according to the character of the tissues encountered by the entering beam. By photographic recording of the echoes, a picture of the tumour or tissue under study is obtained. 'Real-time' imaging allows one to see the scanned object in motion by processing numerous pictures like a movie. The higher the wavelength used, the less the depth of penetration. Ultrasound permits the diagnosis of pregnancy (and of multiple pregnancy) and can determine its viability by the sixth to the eighth week. It can also identify the placental site and detect foetal abnormalities. In gynaecology, it distinguishes between ascites and abdominal tumours, and between uterine leiomyomas, ovarian cysts (benign or malignant) and other masses such as pyosalpinx. The interactivity of ultrasound makes it an extension of clinical examination. Probe palpation can be used to assess tenderness, movement and compressibility.

Ultrasound is a reliable and acceptable method of distinguishing between hydatidiform mole and normal pregnancy (Figs 1.9A and B). It is routinely used in the management of infertility to detect the ripening graafian follicle, for confirmation of ovulation and for ovum pick-up in cases of *in vitro* fertilisation. Ultrasound-guided biopsies and cyst aspiration can also be done.

### TRANSVAGINAL SONOGRAPHY

Transvaginal sonography (TVS) is a valuable adjunct in gynaecology (Fig. 1.10). The TVS probe generates waves

of a higher frequency, i.e. 5.5-7.5 MHz. The closer the probe is to the area which has to be scanned, the higher is the frequency required and the less the attenuation. TVS allows higher resolution imaging of pelvic structures, especially to assess endometrial thickness, follicle size and evaluation of adnexal masses. Thus, it is preferable to abdominal ultrasound in monitoring the induction of ovulation, diagnosis of ectopic pregnancy, distinguishing benign ovarian tumours from malignant ones, in evaluating endometrial lesions and assessing myometrial invasion by endometrial cancer. A major advantage is that it does not require a full bladder. However, its disadvantages are an initial lack of observer orientation to the anatomy and a depth of view limited to about 70 mm.

Instillation of saline through a Foley catheter into the endometrial cavity (sonohysterosalpingography or saline infusion sonography) permits the assessment of tubal patency by transvaginal ultrasound - the fluid is seen passing through the tubes and collecting in the pouch of Douglas. It also permits the delineation of endometrial polyps.

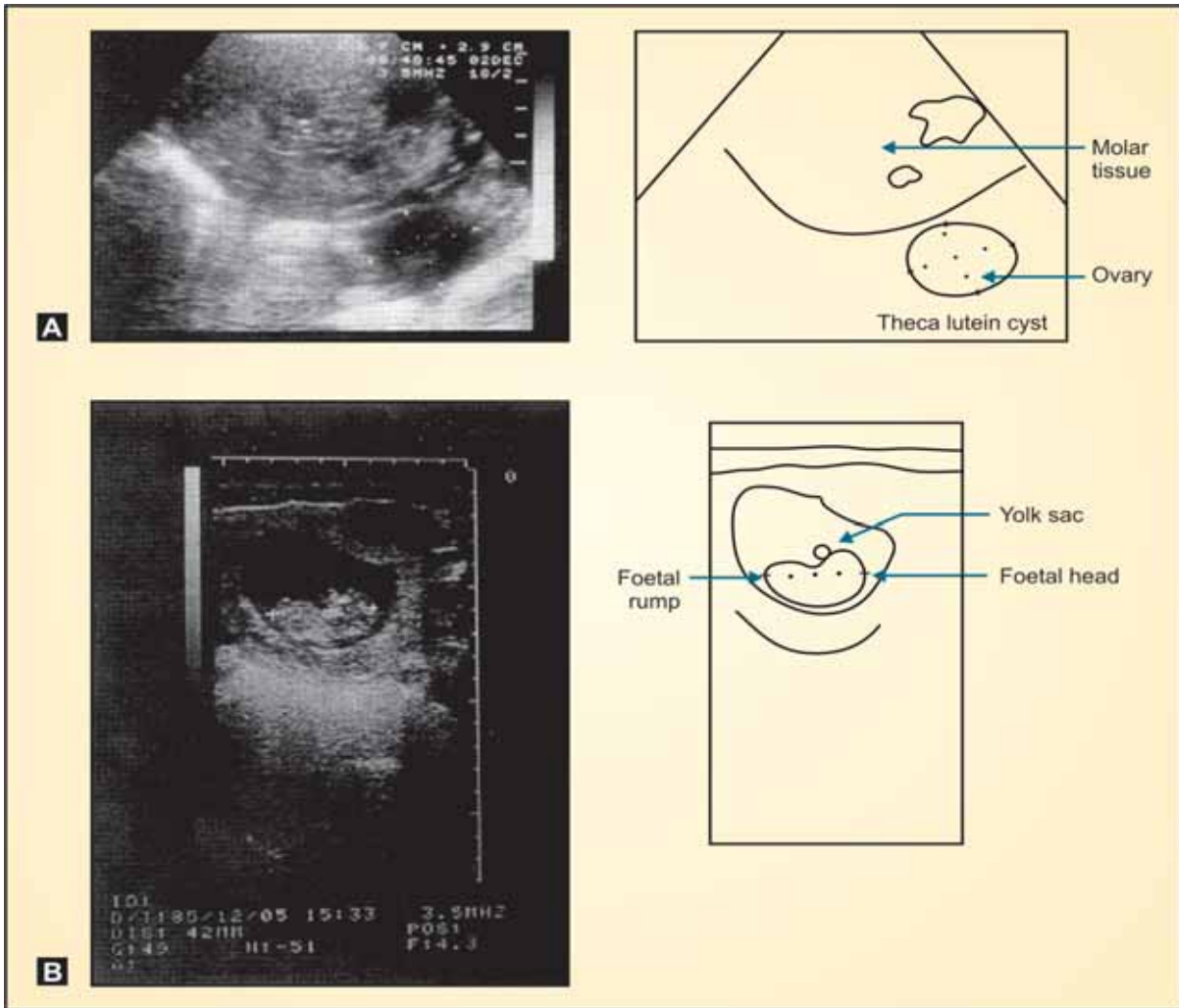
### TRANSRECTAL SONOGRAPHY

The transrectal probe is of particular benefit in the evaluation of cervical lesions and the assessment of parametrial extension of cervical cancers. It is also useful in patients with vaginal stenosis in whom the TVS probe cannot be inserted.

### COLOUR DOPPLER

Another application of ultrasonics is the Doppler device which detects movement — for example, the flow of blood, and translates it into sound (Fig. 1.11). Strictly speaking, Doppler is not ultrasound because it usually falls within the audible range. The Doppler principle uses the shift in frequency of the sound wave, as the source moves relative to the observer to determine its velocity. Using this principle, it requires relatively simple apparatus to detect foetal heart action by the tenth week of pregnancy, and this can be of great help to the clinician. More sophisticated apparatus is able to quantitate blood flow through vessels, e.g. uterine artery, umbilical artery, foetal aorta, carotid and cerebral arteries and is important in managing cases of intrauterine growth restriction and pre-eclampsia. In gynaecology, it is used to diagnose the occurrence of deep venous thrombosis in the lower limbs.

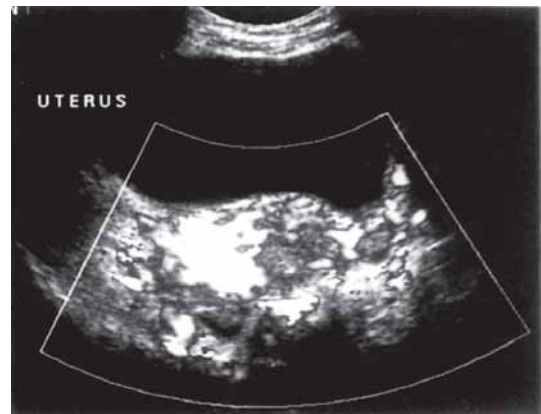




**Figs 1.9A and B:** (A) This ultrasonic scan shows the typical molar tissue filling the uterus and below and to the lower right there is a theca lutein cyst, (B) This shows a normal foetus in its sac with the + mark indicating the crown-rump length of an 11-12-week foetus



**Fig. 1.10:** Transvaginal sonogram with a 7.0 MHz probe showing the uterus in longitudinal section with a central endometrial echo



**Fig. 1.11:** Uterine and adnexal (pelvic) arteriovenous malformation: the extensive colour signal is seen on axial power doppler imaging (courtesy. Dr Manpreet S. Gulati)

The Doppler gate is superimposed on a real-time scan that allows the target to be pinpointed.

Commonly used indices of pulsatility in Doppler ultrasound are:

- *S-D ratio*: It is the ratio of peak systolic to end-diastolic Doppler shift frequencies
- *Resistance index (Pourcelot index)*: It is the difference of maximum and minimum Doppler shifts divided by the maximum
- *Pulsatility index*: It is the difference between maximum and minimum values divided by mean values of the waveform. This value is independent of the Doppler angle, that is, the angle between the ultrasound beam and the axis of the blood vessel.

Transvaginal colour Doppler blood flow studies are useful in predicting whether tumours are benign or malignant. Malignant cell growth is accompanied by neovascularisation and angiogenesis. These vessels are thin-walled and therefore have a low impedance. Thus, benign ovarian cystic tumours may be avascular or relatively avascular and record moderate velocity and high-resistance flow with a resistance index (RI) of about 0.525. The RI falls to 0.322-0.255 in malignant ovarian tumours due to high-velocity and low-resistance blood flow, while the pulsatility index (PI) is <1. Low-resistance flows are also seen in the placenta, corpus luteum and in inflammation.

### Endoscopy

Visualisation of the pelvic organs by way of endoscopes has been employed sporadically since the beginning of the twentieth century, but these diagnostic procedures achieved wide popularity only with the development of modern apparatus which ensures adequate lighting without dangerous heating of the peritoneal cavity.

Endoscopy is now so simple and efficient that there is danger of its being used too freely, to the neglect of standard clinical methods of diagnosis. Instead of analysing symptoms and signs, it is tempting to look and see.

### Laparoscopy

Laparoscopy uses apparatus which incorporates a fibre-optic lighting system for complex inspection of the pelvic organs and for several surgical procedures. In many countries, the earliest laparoscopic procedures were sterilisation operations which involved destruction of

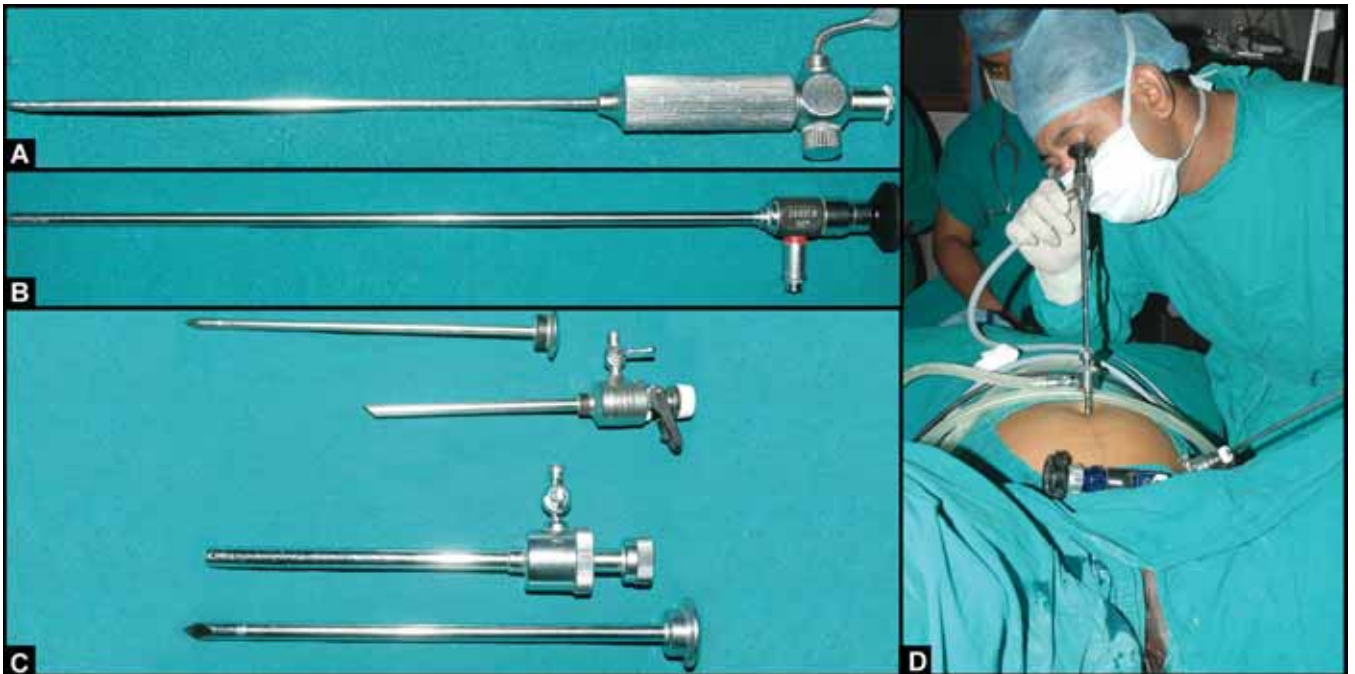
part of the fallopian tubes by diathermy. Later, application of rings or clips was adopted as this destroyed smaller segments of the tubes, offering better prognosis for recanalisation operations, if required. These procedures were and still are done using single-puncture laparoscopes.

Subsequently, diagnostic laparoscopy was developed. This is almost always done using two or more ports, the additional ports allowing the use of a grasper, biopsy forceps or a cannula for suction and irrigation. Diagnostic laparoscopy is used for the investigation of unexplained infertility, to detect small islands of endometriosis, streak gonads, small ovarian tumours, polycystic ovaries and pelvic adhesions. When tubal patency is in question, the passage of an aqueous solution of methylene blue injected via the cervix demonstrates the presence and site of the block.

Operative procedures which can be undertaken simultaneously laparoscopically include ovarian biopsy and cystectomy, aspiration of cyst fluid, the division of peritubal and periovarian adhesions, fimbrioplasty and drainage of hydrosalpinges, ovarian drilling in polycystic ovaries, ablation of endometrial deposits, excision of endometriomata, laparoscopic uterosacral nerve ablation (LUNA), management of ectopic pregnancy and even myomectomy. Advanced operative laparoscopic work includes laparoscopy-assisted vaginal hysterectomy, lymphadenectomy in cases of malignancy, urogynaecologic procedures, etc. Gamete or zygote intrafallopian transfer is done laparoscopically as well.

The procedure involves insertion of a laparoscope under general anaesthesia through the abdominal wall (Figs 1.12A to D). For this to be done safely, the peritoneal cavity has first to be distended with carbon dioxide. The gas, of which as much as several litres may be required, is introduced through a Veress needle inserted in the abdominal wall by way of a tiny transverse incision, usually on the lower rim of the umbilicus. The trocar with its sleeve is inserted through this and made to enter the tense peritoneal cavity just below the umbilicus. The trocar is then replaced by the endoscope. To bring the organs into better view, the uterus can be manipulated by means of a uterine elevator placed in the cervix.

The operator must be reasonably certain that the gut is not adherent to the anterior abdominal wall at the site of entry of the trocar. If there is a previous scar near the umbilicus, access can be sought through the left upper quadrant first in the mid-clavicular line below the ninth

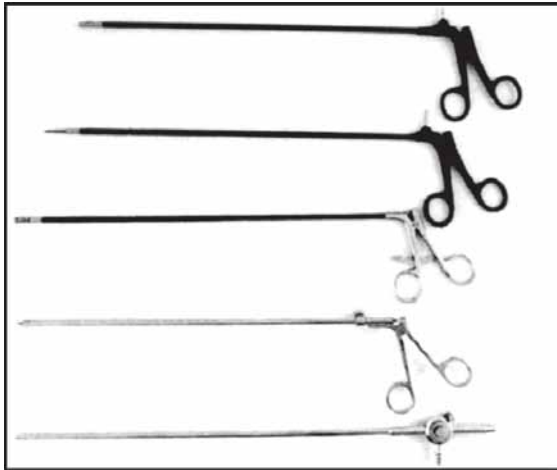


**Figs 1.12A to D:** Laparoscopy. (A) Veress insufflation needle for creating a pneumoperitoneum with carbon dioxide, and (B) the simple laparoscope with its trocar and cannula. (Photographs presented by Down Bros and Meyer and Phelps Ltd.) (C) trocars and cannulas (D) The laparoscope in place with the patient in the Trendelenburg position. The laparoscope has been inserted through a small incision along the lower rim of the umbilicus. Bipolar grasping forceps have been inserted through a small suprapubic incision and are being used to manipulate the pelvic organs. A camera attachment over the eyepiece, if available, permits viewing on a monitor

rib (Palmer's point) and the trocar inserted under vision. Alternatively, the open laparoscopy technique can be used. Additional ports are located in the iliac fossa medial to the inferior epigastric vessels or suprapubically to permit the insertion of various instruments. Hundreds of instruments have now been designed to facilitate all types of surgery laparoscopically (Fig. 1.13A). Monitors with built-in controls permit autoregulation of gas-flow rates, intra-abdominal pressure, etc. to increase safety. The use of a camera and video monitor allows the entire team to visualise the procedure (Fig. 1.13B). The proceedings can also be recorded. For tissue division, scissors, electrodiathermy or laser can be used. Various lasers currently in use include the CO<sub>2</sub>, Nd:YAG, KTP, argon and holmium. Each has its own cutting and coagulating abilities and the choice of laser depends on the task at hand. Suturing and stapling devices can be used as required.

At the conclusion of the operation, the gas is expressed from the abdomen by way of the cannula. The skin incision is closed with one or two clips or sutures which are removed 5 days later.

The complication rate of laparoscopy depends on the experience of the surgeon but for large series it is about 0.1-0.2 per cent. Some patient-related parameters such as obesity and a prior history of abdominal surgery may increase the incidence of complications. Complications of laparoscopic surgery can be divided into two phases - the first is the creation of the pneumoperitoneum, the second is the operation itself. The insertion of the Veress needle and the first trocar are carried out blind and are the most hazardous part. Injury to major blood vessels, bowel or bladder may ensue. Damage by the lateral trocars can result in damage to the inferior epigastric vessels, haematoma formation or incisional hernia if a 10 mm port is used. Carbon dioxide embolism can be fatal. Ureteric damage, pulmonary embolism and infection can also occur. Burn injury is more likely from monopolar than from bipolar coagulation. To increase the safety of the procedure, special sheathed trocars have been devised. In the alternative system of open laparoscopy, the rectus sheath is incised and the peritoneum opened under direct vision. However, some bowel injury can still occur.



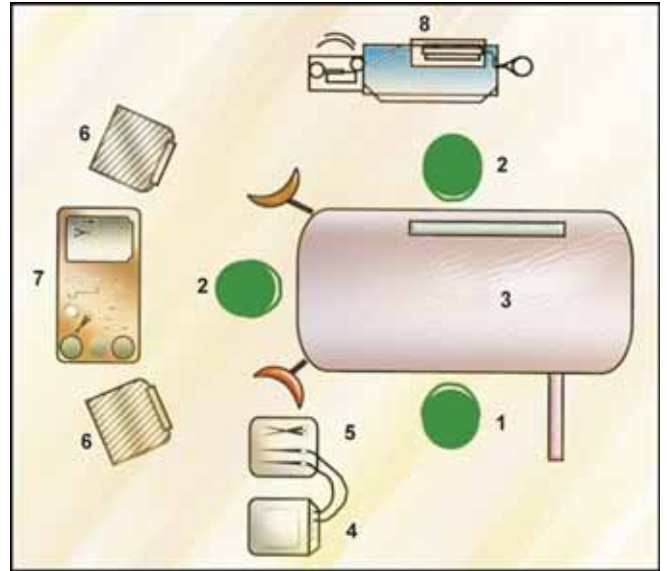
**Fig. 1.13A:** Instruments for operative laparoscopy: (from above down) serrated edged grasper without lock; pointed atraumatic grasper; serrated edged grasper with lock; curved scissor; irrigation aspiration suction cannula

Gasless laparoscopy is done using mechanical abdominal wall elevators placed through one or more openings in the abdomen. These use simple suspensory chains on sophisticated equipment. This avoids the complications of CO<sub>2</sub> insufflation and may be useful in combined laparovaginal procedures. However, there is a risk of trauma and pressure ischaemia to the abdominal wall; visualisation of the lateral pelvic wall is impaired by the triangular shape of cavity distension; lack of abdominal pressure allows the bowel to come into the operative field.

Laparoscopy is contraindicated in severe cardio-respiratory disease, massive intra-abdominal haemorrhage, acute intestinal obstruction, severe intra-abdominal adhesions, very large intra-abdominal masses and untreated advanced malignancy.

### Hysteroscopy

It is possible to visualise the cavity of the uterus with hysteroscopes incorporating fibre-optics (Figs 1.14A and B). Several media have been used to distend the uterine cavity: 32 per cent dextran, 5 per cent dextrose in water, normal saline, carbon dioxide and 1.5 per cent glycine. While any of the media maybe used for diagnostic hysteroscopy, operative hysteroscopy which uses electrocautery is done using 1.5 per cent glycine, i.e. a non-electrolyte solution, as the distention medium. Hysteroscopy is used to exclude intrauterine pathology

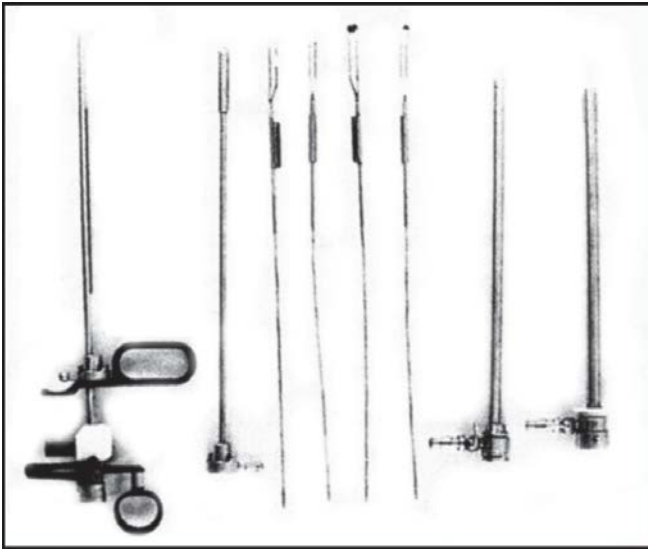


**Fig. 1.13B:** Operating room layout: 1 surgeon; 2 assistant, scrub nurse; 3 patient table with stirrups (arms are placed as indicated); 4 electro-surgical cart; 5 surgeon's instrument trolleys; 6 video display monitors with VCR power source; 7 operating instruments table; 8 endoscopic supply cart with CO<sub>2</sub> insufflator and suction machine

as a cause of abnormal bleeding or infertility, such as myomas, polyps, and foreign bodies, e.g. misplaced intrauterine contraceptive devices (IUCDs) and bony fragments following incomplete abortion. It also offers an opportunity for their removal. In the diagnosis of endometrial carcinoma, it may be used for taking a guided biopsy but there is a theoretical risk of



**Fig. 1.14A:** Diagnostic hysteroscope (4 mm) with sheath and pressure bag



**Fig. 1.14B:** Instruments for operative hysteroscopy: resectoscope with obturator, wire loop electrode, Collin's knife, roller ball electrodes and sheaths

disseminating malignant cells into the peritoneal cavity. Women with oligomenorrhoea or amenorrhoea may be found to have intrauterine synechiae, atrophic endometrium or chronic endometritis. Synechiae can be divided under hysteroscopic guidance. Other hysteroscopic procedures include endometrial ablation, resection of intrauterine septa and proximal fallopian tube cannulation. Hysteroscopic sterilisation using sclerosing chemicals (quinacrine, methylcyano-acrylate, silver nitrate), injectable chemicals (silicone rubber), mechanical devices and electrocautery has been tried but has not been universally accepted.

The procedure involves dilatation of the cervix followed by introduction of the hysteroscope. The hysteroscope has a side channel which permits the passage of the distension medium. For operative hysteroscopy, an additional channel permits the introduction of the resectoscope, roller ball or laser fibre. An outflow tract allows the fluid passing out to be collected in a bottle. Special collecting bags have been devised which are placed under the patient's buttocks to collect any fluid leaking out of the vagina to allow as accurate an estimation as possible of the fluid deficit and thus prevent fluid overload. Office hysteroscopy is a diagnostic procedure done under local anaesthesia using a hysteroscope of smaller diameter (<4 mm) so that cervical dilatation is not required.

Complications of hysteroscopy include uterine perforation, haemorrhage, mechanical or burn injury to intra-abdominal viscera and vessels, and fluid overload, especially with the use of non-electrolyte solutions. Delayed complications include infection, secondary haemorrhage, haematometra, cyclical pain and treatment failure with recurrence of symptoms. Hysteroscopy is contraindicated in the presence of infection (except in the case of a misplaced IUCD), in pregnancy and in cervical malignancy. In the presence of bleeding, it may pose some difficulty, especially to the novice.

### Computed Tomography

Computed tomography (CT) is able to demonstrate the pelvic anatomy very clearly. Contrast enhancement is the standard technique - opacification of the gastrointestinal tract with oral contrast and of the bladder and blood vessels with intravenously administered contrast enables the pelvic organs to be delineated clearly. Scanning begins at the level of the iliac crest and moves to the symphysis or ischial tuberosities. The thickness of each slice is 5-10 mm and the procedure is usually done in the supine position using axial scanning.

CT scanning is especially useful in the evaluation of pelvic masses to identify the organ of origin, to stage pelvic cancer (supplemented by abdominal CT), and in the follow-up of cancers to detect recurrence of disease (Fig. 1.15). Lymph node involvement and uterine lesions are well demonstrated. However, cervical cancers and parametrial invasion are not accurately evaluated. Tumours less than 2 cm in size may not be detected and normal ovaries may not be identified routinely. CT-guided procedures such as biopsy or aspiration are sometimes done for diagnostic or therapeutic purposes.



**Fig. 1.15:** Axial contrast-enhanced CT showing a simple cyst in the right adnexal region and anterior to the uterus

### Magnetic Resonance Imaging

Magnetic resonance imaging (MRI) is the latest addition to the armamentarium of diagnostic modalities, but is still not available in most parts of the developing world. It uses the property of nuclear magnetic resonance (NMR). Certain atomic nuclei, when placed within a magnetic field and stimulated by radio waves of a specific frequency, will absorb and then re-emit some of this energy as a radio signal (Fig 1.16). Data for each set of images is accumulated over about 5 minutes and patients need to remain still for this period. The total process can take 30-60 minutes. The female pelvis is particularly suitable for MRI because it does not move with respiration. Congenital anomalies of the uterus and lesions of the myometrium and endometrium can be most accurately demonstrated by MRI.

MRI has several advantages over CT scan; there is no radiation exposure, imaging is multiplanar hence pictures can be obtained in sagittal, oblique or other planes; contrast is not required; soft tissue contrast resolution is superior to CT. Thus, it is more useful in patients with tumours. However, it cannot be used in patients with pacemakers or metallic implants; interventional



**Fig. 1.16:** T<sub>2</sub>-weighted sagittal MR image showing a large hypointense uterine fundal leiomyoma

procedures cannot be performed; the costs are higher; time taken is longer and this is particularly a problem for those who feel claustrophobic in confined spaces. Absence of signals from bony structures means that certain characteristic features such as teeth in a dermoid cyst, which can be picked up on a straight X-ray, will be missed on MRI!

# CHAPTER 2

## Anatomy

Vulva	21	Rectum and Anus	42
Vagina	25	Pelvic Peritoneum and Ligaments	43
Uterus	30	Pelvic Musculature	44
Fallopian Tubes	34	Pelvic Fascia and Cellular Tissue	45
Ovary	36	The Supports of the Genital Organs	46
Urethra and Bladder	37	Blood Vessels of the Pelvis	47
Ureter	41	Lymphatic Drainage	51
Sigmoid Colon	41	Innervation of Pelvic Organs	53

It is essential to realize that nothing is more fundamental to the knowledge base of the practicing gynaecologist than an understanding of the anatomy of the female pelvis. Although the basic facts of anatomy and their relevance to gynaecologic practice do not change with time, our understanding of specific anatomic relationships and the development of new clinical and surgical correlations continue to evolve. It is very essential to review relevant anatomy before each surgical procedure. We need to study the gynaecologic literature on an ongoing basis—numerous publications have documented the evolution of newer concepts regarding anatomic issues such as pelvic support.

### VULVA

The vulva is a composite name for the external genitalia (Fig. 2.1). It includes the mons veneris, the labia majora and minora, the clitoris, the entrance to the vagina, the hymen and the vestibule; but the term is ill defined and many regard it as covering deeper structures such as the vestibular bulbs and Bartholin's glands as well. Some gynaecologists regard the perineum as part of the vulva, and many include under this term the perineal body (central tendon of the perineum) as well as the overlying skin. To anatomists, 'perineum' means all structures within the bony outlet of the pelvis. For convenience, the perineum is considered with the vulva.

### INDIVIDUAL STRUCTURES

#### Mons Veneris and Labia Majora

The mons is the hair-bearing skin and the fatty pad which overlies the upper part of the symphysis pubis and the lower abdominal muscles; it acts as a coital buffer. Extending backwards from the mons, on either side of the vaginal orifice, are the

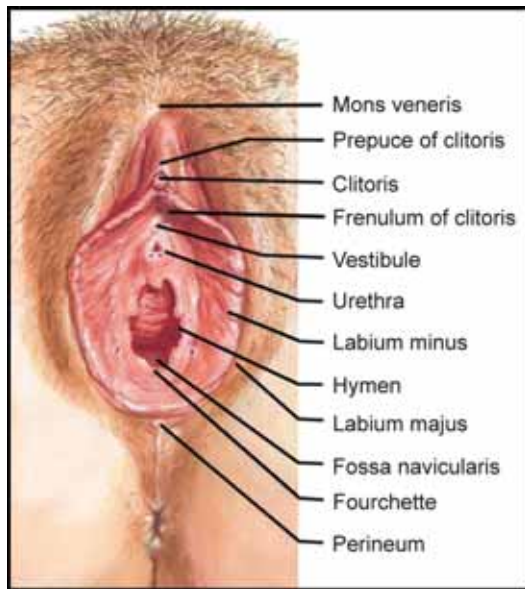


Fig. 2.1 The virginal vulva

labia majora which are folds of skin with underlying deposits of fat. These are homologous to the scrotum. Posteriorly they merge into each other and into the perineal skin. Their outer aspects are covered with hair, their inner are smooth and moistened by the secretions of sebaceous and other glands. Except where the labia minora intervene, the inner surfaces ordinarily lie in contact with each other, and thus close the entrance to the vagina.

The mons and labia majora are covered with coarse skin which contains hair follicles, sebaceous glands and sweat glands. Some of the latter are large, coiled and specialized and are known as *apocrine glands*; these are only found in certain areas of the body such as the axilla and vulva, and their secretion (when modified by bacteria) gives rise to a characteristic odour which is of sexual significance.

In view of their structure, the mons and labia majora are exposed to ordinary diseases of the skin including conditions such as psoriasis, sebaceous cysts, boils and carbuncles, and new growths. Because the underlying connective tissue is very loose, the labia readily become oedematous.

### Perineum

The perineum comprises the less hairy skin and subcutaneous tissue which lie between the vaginal orifice

and the anus and cover the muscular *perineal body* (see page 45). Its length from before backwards, which varies from 2 to 5 cm or more, influences the resistance it offers and the injuries it sustains during childbirth. The median raphe seen in the male is usually, but not always, absent in the female, this being explained by slight differences in development. Unlike the rest of the vulva, the perineum has very little subcutaneous fat so the skin is close to the underlying muscles.

### Labia Minora

The labia minora are delicate flaps of soft skin lying within the labia majora, one on each side of the vaginal orifice, and are homologous to the floor of the penile urethra in the male. They vary considerably in size and may be hidden by the labia majora or may project between them. Ordinarily, their inner surfaces lie in contact with each other and their outer surfaces in contact with the labium majus on the same side. Anteriorly the labia minora join together and in so doing split to provide the clitoris with a prepuce and frenulum. They join posteriorly to form a sharp fold of skin, *the fourchette*, and they also merge into the labia majora. The fourchette is nearly always injured during childbirth, and sometimes suffers slight tearing during initial attempts at coitus. The depression between the fourchette and hymen which is found in virgins is the *fossa navicularis*.

The labia minora each consist of two layers of non-keratinized skin with some intervening loose connective tissue. The latter is devoid of fat but is so vascular that it enables the labia to become turgid under conditions of sexual excitement. They also contain sebaceous glands, especially near their bases, but few, if any, sweat glands.

### Clitoris

The clitoris is the homologue of the penis and is a small structure lying on the front of the symphysis almost hidden by the foreparts of the labia majora. It has a glans, prepuce, body and two crura (corpora cavernosa) which attach it to the pubic bones. The clitoris consists of erectile tissue richly supplied with nerves which make it the most erotically sensitive part of the vulva. Smegma is secreted beneath the prepuce. Only the glans and prepuce are visible, but the body is palpable against the symphysis pubis as a small cord-like structure approximately 2 cm in length.

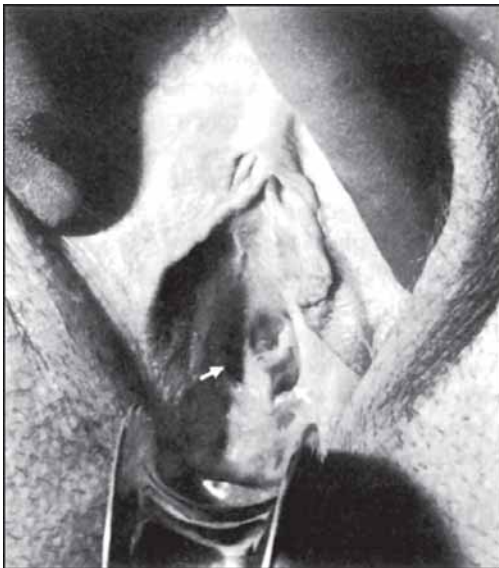


## Vestibule

The definition of vestibule (from the Latin *vestibulum* meaning a forecourt or a hall next to the entrance) varies, but generally the term is applied only to the area of smooth skin lying within the labia minora and in front of the vaginal orifice. The urethra opens on to it. On either side of the urethral meatus are tiny depressions called *paraurethral pouches* with adjacent insignificant folds - the *urethral labia*.

## Hymen

The hymen is a delicate incomplete membrane guarding the entrance to the vagina prior to maturity and sexual experience (Fig. 2.2). It has one or more apertures to allow the outflow of menstrual blood and, according to their number and shape, is described as being annular, crescentic, septate or cribriform. Unless the opening is unusually large, and the hymen itself particularly elastic, coitus nearly always causes tearing. The tear is most commonly found posteriorly or posterolaterally. It is one of the signs of loss of virginity, but is not a very reliable one because injuries may be caused by operations, digital



**Fig. 2.2:** The normal vulva (shaved) with the introitus opened to show an intact hymen. For identification of the structures, compare with Fig. 2.1. In this case the hymen is unusually well developed to form a thick tough membrane with two small openings (posterolateral to the external urethral meatus and indicated by white arrows) which allowed the escape of menstrual blood. This so-called septate hymen would probably have hindered consummation of marriage

interference or the insertion of tampons to contain the menstrual discharge. Moreover, coitus can take place without a tear resulting. Inspection alone is often insufficient to permit a conclusion that a hymen is intact and unstretched; a better clinical test is to feel gently for its resistant edge with the tip of the finger.

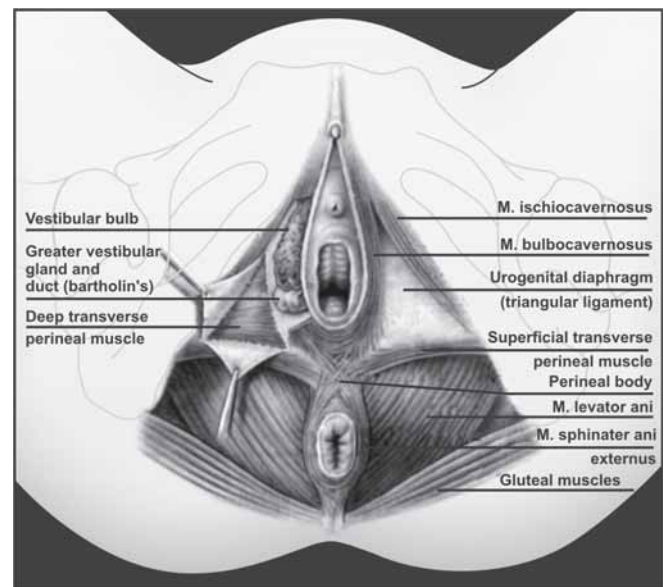
The hymen is relatively avascular so its tearing usually causes only a slight loss of blood. During childbirth the hymen is destroyed, its remains being a few tags around the vaginal orifice - *carunculae myrtiformes*.

## Vestibular Bulb

The two bulbs are collections of erectile tissue which together are homologous to the corpus spongiosum in the male. Each passes backwards from the root of the clitoris, lying deep to the bulbospongiosus (bulbocavernosus) muscle (sphincter vaginae) but superficial to the lower layer of the triangular ligament (urogenital diaphragm), the compressor urethrae (external urethral sphincter) and the deep transverse perineal muscles (Fig. 2.3).

## Bartholin's Glands (Greater Vestibular Glands)

Bartholin's glands are two in number and are homologous to Cowper's glands in the male. They lie postero-



**Fig. 2.3:** The urogenital diaphragm (triangular ligament) and associated structures as seen from below

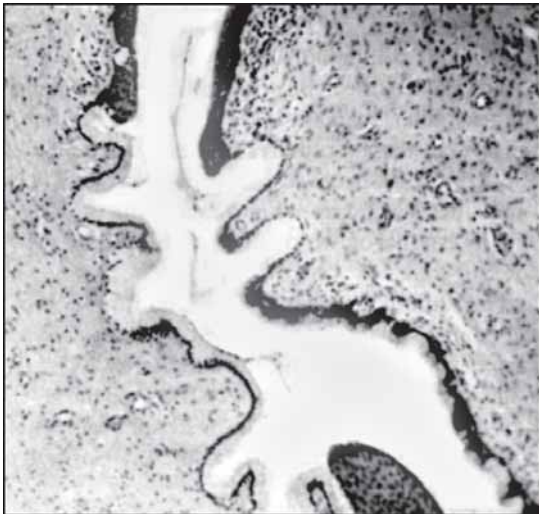
laterally to the vaginal orifice, embedded in the posterior part of the vestibular bulb, one on either side (Fig. 2.3). Each gland is oval in shape and approximately the size of a pea but is impalpable unless hardened or enlarged by disease. Its duct is 1.25-2 cm in length, and runs downwards and inwards to open at the introitus below the hymen but above the attachment of the posterior end of the labium minus (Fig. 2.3). The orifice of the duct is not normally visible but, when the duct and gland are infected, may be indicated by a small red area.

The gland is lobulated and racemose, the acini being lined by a single layer of low columnar or cuboidal cells (Fig. 2.4). The duct is lined by multilayered columnar cells and not by transitional epithelium, as is usually stated. The impression of the latter is created by a study of pathological states. Thus the surface columnar cells become flattened when the duct is distended to form a cyst; and infection may sometimes result in metaplasia.

The secretion of the gland is colourless and mucoid and has a characteristic odour. It is produced mainly in response to sexual excitement when considerable amounts are poured onto the vulva to act as a lubricant for coitus. The gland continues limited activity after the menopause.

#### *Changes in the Vulva with Age and Parity*

The tissues of the vulva are sensitive to sex hormones, especially oestrogens, so their anatomy and function



**Fig. 2.4:** The duct of Bartholin's gland, at the top, joining the gland lined by columnar epithelium. The duct is lined by immature metaplastic squamous epithelium. When the duct is distended by cyst formation this can become flattened to give a false impression of its true morphology

change with age and the endocrine environment. In infancy and childhood the mons veneris and labia majora are devoid of hair. In the very young baby the labia majora are under the influence of maternal hormones and tend to obscure the tiny labia minora, but the vaginal orifice is seen surprisingly easily when the legs are abducted. Later, the labia lose their fat so the labia minora and the clitoris are relatively prominent and protruding. During childhood the skin of all the tissues is thin and delicate and that of the vestibule reddish in colour. Fat reappears in the mons and labia majora as part of sexual development in adolescence, and the labia minora and vaginal orifice then become hidden. The growth of pubic hair is an early sign of puberty.

The effect of coitus on the hymen has already been described. The fourchette and the perineum are frequently torn during childbirth and thereafter appear scarred. Deep tearing may leave the perineum shorter than it was originally; the vaginal orifice then becomes wider and more exposed because of separation of the posterior parts of the labia majora.

In old age all the tissues atrophy and the skin becomes drier, thinner and glazed. The subcutaneous fat is lessened except in obese women. The labia minora shrink and may almost disappear. The vaginal orifice tends to contract. Pubic hair becomes sparse.

#### *Relations*

An understanding of the relations of the vulva rests on an appreciation of the position of its component parts in relation to the bony pelvis, and this is illustrated in Figs 2.3 and 2.5.

#### *Vascular Connections*

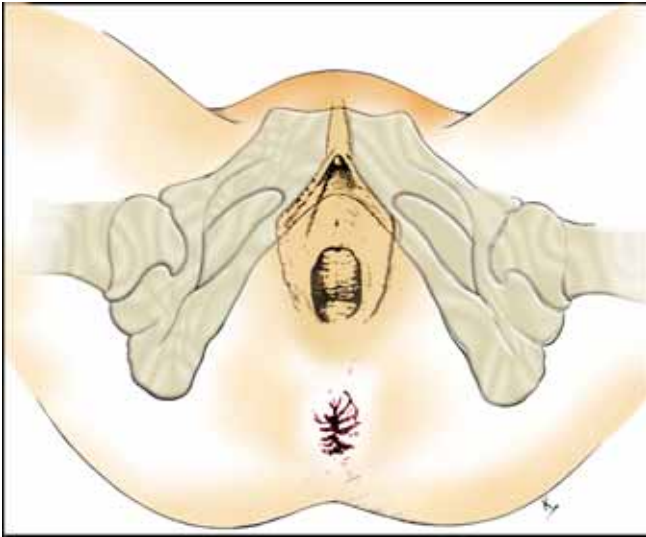
All the tissues of the vulva are extremely vascular, so even a minor operation in that area should not be attempted except in well-equipped surroundings.

#### *Arterial*

The vulva is mainly supplied by branches of the internal pudendal artery, which is one of the two terminal branches of the internal iliac artery, but its foreparts are also served by the superficial external pudendal artery.

#### *Venous*

Some veins accompany corresponding arteries to the internal pudendal vein; those of the clitoris and bulb link



**Fig. 2.5:** The relation of the tissues of the vulva to the bones of the pelvis. Note that the clitoris lies relatively high on the symphysis pubis. The introitus is depicted as multiparous and gapes to show rugae and a central column on the anterior vaginal wall

with the vesical and vaginal plexuses. The long saphenous vein also takes a share of the venous return; ligating it can improve vulvar varicosities.

#### Lymphatic

Drainage is mainly to the superficial inguinal nodes, and thence to the deep inguinal and external iliac nodes. Lymphatics from the deep tissues accompany the internal pudendal vessels to the internal iliac nodes.

#### Innervation

See page 53.

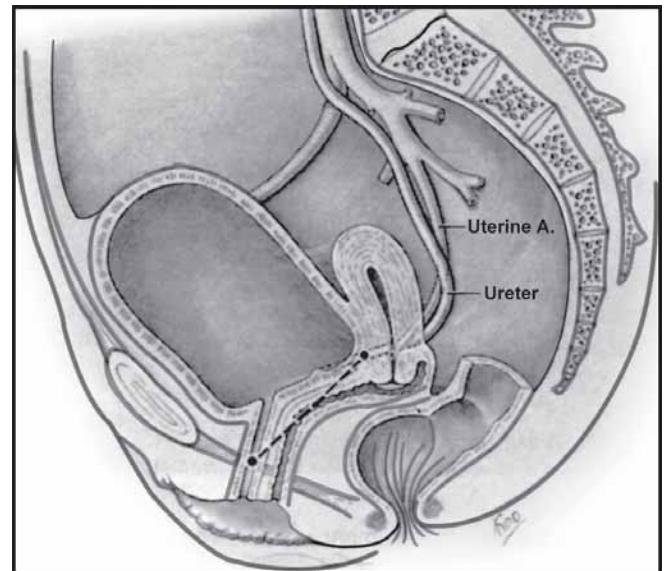
## VAGINA

### General Description

The vagina is an elastic fibromuscular canal extending upwards and backwards from the vulva at an angle of 60-70 degrees to the horizontal, although it is not straight as is generally supposed but angled backwards (Figs 2.6 and 2.7). That this is so is demonstrated not only by colpographs but by the taking of casts of the vagina in the living woman. The vagina pierces the triangular ligament and the pelvic diaphragm, the level of these



**Fig. 2.6:** Lateral urethrocytograph and colpograph in a normal multiparous woman sitting at ease. The urethra is straight and joins a relatively flat bladder base to produce what appear in silhouette as clearly defined 'angles' in front of, and behind, the urethrovesical junction. The vagina is not straight but slightly angulated to conform to the anatomy of the urethrovesical junction. (By permission of the Editor, *J Obstet Gynaecol Br Empire*)



**Fig. 2.7:** The relations of the bladder, urethra and vagina as seen from the side. The two dots represent fixed points; the broken line joining them marks the position of the trigone and urethral floor during micturition

structures being approximately 1 and 2.5 cm, respectively, from its lower end. The vagina has a blind upper end except for the cervix with its external os, which projects through its upper anterior wall.

The vault of the vagina is divided into four areas according to their relations to the cervix: the *posterior fornix* which is capacious, the *anterior fornix* which is shallow, and two *lateral fornices*. Because the cervix is inserted below the vault, the posterior vaginal wall is approximately 10 cm, whereas the anterior wall is approximately 8 cm, in length.

The introitus is functionally closed by the labia which are in contact with each other. Moreover, the lumen of the vagina is ordinarily obliterated by the anterior and posterior walls lying in apposition. In its lower part it appears H-shaped on cross-section with lateral recesses anteriorly and posteriorly. When, however, a woman is in the knee-chest, Sims' or kneeling position, and the labia are separated, the vagina balloons out. This is the result of a negative intra-abdominal pressure transmitted to the vagina, causing the entry of air. Exceptionally, such air can enter the uterus, tubes and peritoneal cavity.

If the walls are separated, the vagina of the nulliparous married woman has a diameter of approximately 4-5 cm at its lower end and is twice as wide at its upper end. Although the width and length of the vagina show considerable individual variations, anatomical shortness or narrowness is rarely a cause of difficulty or pain on coitus because the vagina is distensible and accommodates itself. The functional width is determined to a large extent by the tone and contractions of surrounding muscles.

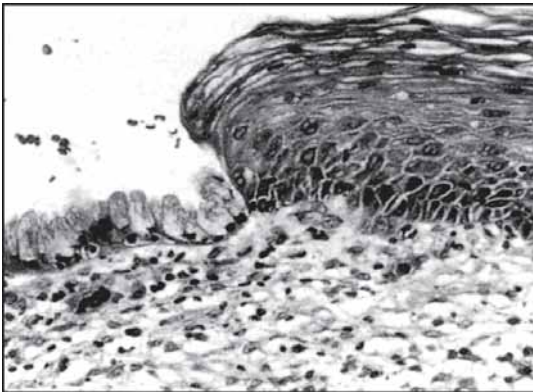
A raised double column formed by underlying fascia can often be seen running sagittally down the anterior

wall and there is a less definite median ridge on the posterior wall. Running circumferentially from these columns are folds of epithelium (*rugae*) which account in part for the ability of the vagina to distend during labour (Fig. 2.5).

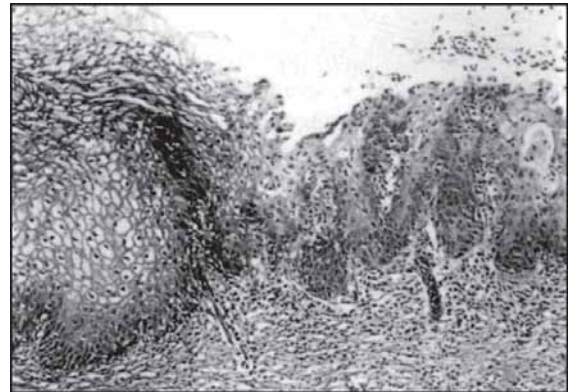
## STRUCTURE

### Epithelium

The vagina is lined by stratified squamous epithelium which also extends onto and covers the vaginal cervix as far as the external os (Figs 2.8 and 2.9). The surface is normally devoid of keratin but is capable of becoming keratinized if it becomes exposed to the air as in prolapse. The epithelium is many layered, the basal cuboidal cells being the source of a continuous production of the squamous cells above. The cells in the middle and superficial zones contain glycogen, which explains why the vagina stains deep brown with iodine. It shows cyclical histological changes in association with menstruation. The epithelium does not contain glands of any kind and does not secrete in the ordinary sense of the word. The frequently used term vaginal *mucosa* is, therefore, strictly incorrect. Although it may in part represent a transudate (globules of fluid, *'the sweating phenomenon'*, are said to collect on the surface during coitus and sexual excitation), the vaginal 'secretion' arises mainly from the constant breakdown of superficial epithelial cells. This breakdown liberates the contained glycogen which is acted upon by the lactobacillus



**Fig. 2.8:** Cervix, squamocolumnar junction. The section shows the abrupt transition from the single layer of endocervical mucus-secreting epithelium on the left, to the mature, multilayered squamous epithelium of the ectocervix on the right. (Photomicrograph x400)



**Fig. 2.9:** Cervix, transformation zone. To the left, is seen the mature, well-glycogenated squamous epithelium of the ectocervix, and to the right, the immature metaplastic squamous epithelium of the transformation zone. (Photomicrograph x120)

(Doderlein's bacillus), a normal inhabitant of the vagina, to produce lactic acid. The vaginal 'secretion', therefore, consists of tissue fluids, epithelial debris, electrolytes, proteins and lactic acid. The amount of the last is governed by the glycogen content of the epithelium and the presence of lactobacilli but, in the adult healthy vagina, is in a concentration of 0.75 per cent.

The pH varies with the level of the vagina, being highest in the upper part because of an admixture of alkaline cervical mucus. Estimates also vary, according to the method used for its determination. Some authorities give the normal range for the adult non-pregnant woman as from 3.5 to 4.2, but the generally accepted figures are from 4.0 to 5.5 with an average of 4.5. The level varies with the time in the menstrual cycle and the effects of ovarian hormones on the vaginal epithelium and the cervical secretion. During menstruation the flow of alkaline blood raises the vaginal pH to levels ranging from 5.8 to 6.8.

The acidity of the vagina is of great practical importance for it explains the resistance of the mature vagina to pyogenic organisms.

The vagina not only 'secretes'; it absorbs water, electrolytes and substances of low molecular weight. This property is utilized when therapeutic agents such as oestrogens and glucose are administered locally, and can be a nuisance in that it permits the absorption of medicaments such as mercurials and arsenicals to cause systemic reactions. Absorption and reabsorption are believed to occur mainly in the lateral recesses of the lower vagina.

### Fascia and Muscle

The epithelium rests on a subepithelial connective layer which contains elastic tissue. Outside this are muscle coats in which the fibres are nearly all arranged in a criss-cross spiral fashion. The muscle of the vaginal wall is involuntary in type although there are sometimes a few intermingling voluntary fibres contributed by muscles such as the levatore ani at the sites of their insertions.

Outside the muscle layers is a strong sheath of connective tissue which has special condensations down the anterior wall to form the *pubocervical fascia*, and down the posterior wall to form the *rectovaginal fascia*. This fascial sheath fuses with that covering the levator ani muscles, the triangular ligament and perineal muscles (Fig. 2.10).

The vaginal wall itself and the tissues around it are extremely vascular so they usually bleed freely at the time of injury and operation.

### Changes in the Vagina with Age and Parity (Fig. 2.11)

The vagina of the newborn child is under the influence of oestrogen which has crossed the placenta from the maternal circulation. The epithelium is therefore moderately well developed and contains glycogen. Lactobacilli appear by the third or fourth day when the vaginal acidity approaches that of an adult. By 10-14 days the oestrogen stimulus is lost and the epithelium atrophies becomes devoid of glycogen. The pH then rises to approximately 7 and remains at that level until the approach of puberty when, with the onset of full ovarian function, the vagina assumes the features already described. Throughout childhood, lactobacilli are present in small numbers but after puberty they are the predominant organism. During pregnancy the amount of glycogen is increased to a maximum and the acidity of the vagina is high (pH 3.5-4.5). After the menopause the epithelium atrophies and loses its glycogen. Lactobacilli are found in fewer numbers and the pH rises to a range of 6-8. In some women menopausal atrophy is slow to develop, possibly because of the peripheral conversion of androgens produced by the adrenal cortex to oestrone.

Marriage and regular coitus result in some stretching of the vaginal walls, and this is increased by childbearing.

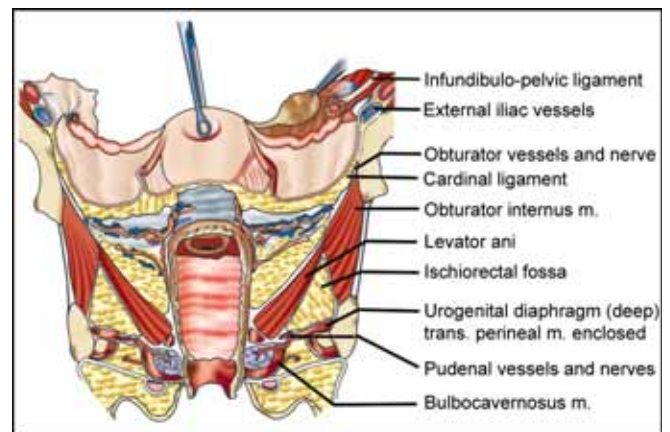
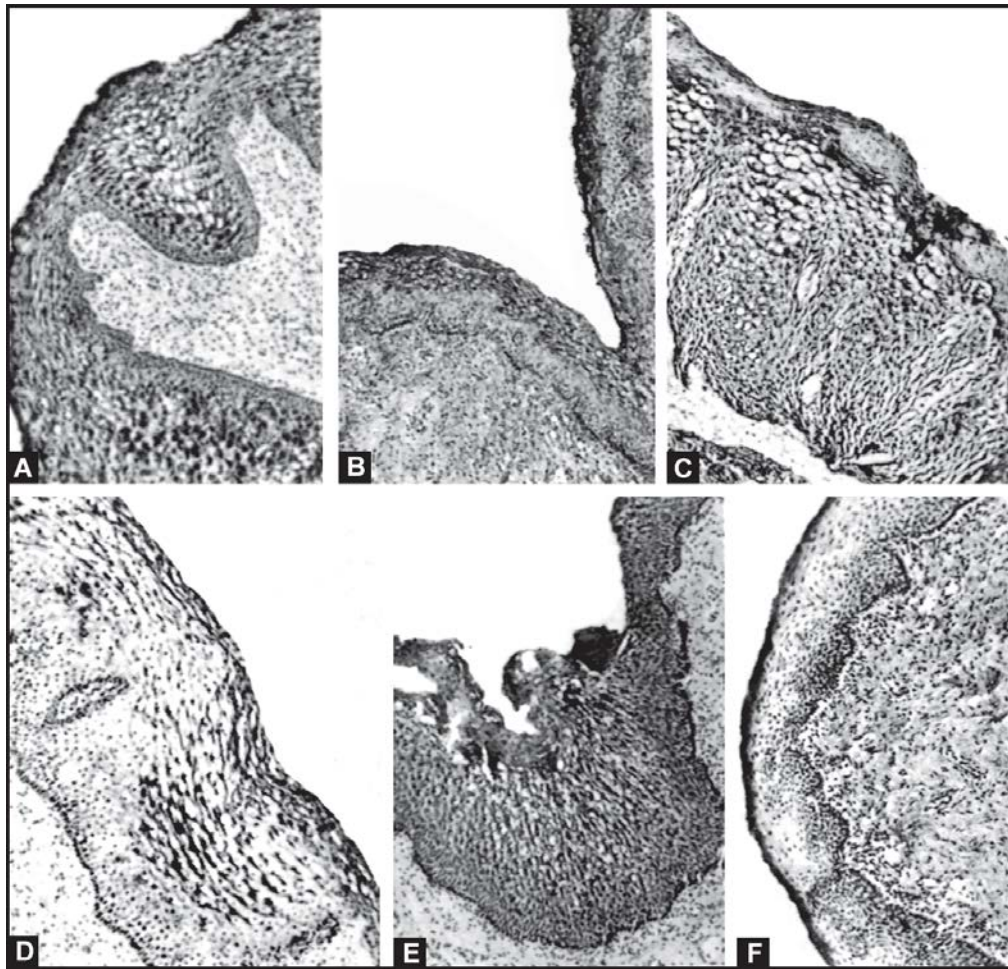


Fig. 2.10: The pelvic muscles, ligaments and fascia as seen from the front



**Figs 2.11A to F:** The characteristics of the vagina at different ages (By permission of the late Mr R.L. Hartley)

	<i>Newborn infant</i>	<i>Six-week-old child</i>	<i>Puberty</i>	<i>Sexual maturity</i>	<i>Pregnancy</i>	<i>Late post-menopausal</i>
Oestrogenic hormone stimulus	Present	Negligible	Appears	Present	Large amount	Small amount
Epithelium	A	B	C	D	E	F
Glycogen	Present	Absent	Appears	Present	Large amount	Small amount
Acidity	pH 4.5-7.0	pH 7.0	alkaline → acid	pH 4.0-5.5	pH 3.5-4.5	pH 6-8
Flora	Sterile → Lactobacilli	Sparse coccal varied flora	Sparse coccal flora	Lactobacilli	Lactobacilli	Varied flora

Repeated childbirth leads to obliteration of the rugae and the vagina becomes a smooth-walled and rather patulous canal. After the menopause it undergoes contracture in length and width, but this change is to some extent counteracted by the continuance of regular coitus. The fornices become shallow, however, and the cervix no longer projects far into the vault. When these changes are extreme the vagina is said to become tent-shaped. Even in nulliparous women, the vagina loses its rugae after the climacteric.

### *The Supports of the Vagina*

See page 46.

## The Relations of the Vagina

### *Anterior*

Embedded in the lower anterior vaginal wall is the urethra. Its muscles fuse with those of the vaginal coat without the intervention of fascia so it is difficult to separate from the vagina at the time of operation. In close connection too are *Skene's tubules* which open into the urethra (see page 34). Above the urethra, the vagina is directly related to the bladder, separated from it by fascia and loose areolar tissue (Fig. 2.7).

### *Posterior*

From below upwards the vaginal wall is in relation to the perineal body, the ampulla of the rectum and the peritoneum of the pouch of Douglas. At the level of the posterior fornix there is only vaginal wall, fascia and extraperitoneal cellular tissue separating the peritoneal cavity from the exterior (Fig. 2.12).

### *Lateral*

At its orifice the vagina has on either side the sphincter vaginae (bulbospongiosus) muscle, the vestibular bulb, Bartholin's gland and its duct, and the triangular ligament (urogenital diaphragm) with its muscles. At a higher level is the levator ani with the paracolpos above, and the ischiorectal fossa below its insertion. The lateral fornix is related to the lower parts of the cardinal ligament which are inserted into it (Fig. 2.10).

### *Superior*

The cervix dips into the upper and anterior part of the vagina; above this is the uterus itself. Overlying the

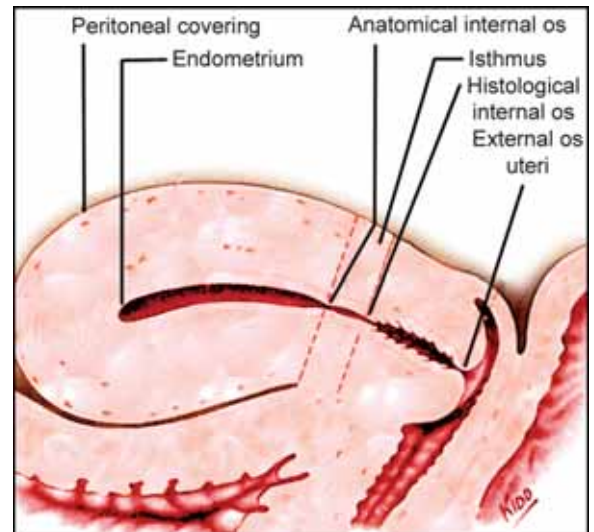


Fig. 2.12: The uterus from the side

lateral fornix and situated only 1-2 cm away is the ureter with the uterine vessels immediately above. These lie in the cellular tissue of the base of the broad ligament which is also an important relation. The uterosacral ligaments are just above the posterior fornix; between and above them is the peritoneal pouch of Douglas containing loops of intestine. Above and to the side are the fallopian tube and ovary (Fig. 2.10).

## Vascular Connections

### *Arterial*

These are: the vaginal artery mainly; branches of the uterine artery; branches of the internal pudendal artery; and twigs from the middle and inferior rectal arteries (see page 48).

### *Venous*

A plexus of veins around the vagina connects with those around the bladder and rectum, and ultimately drains into the internal iliac veins by branches which mainly accompany corresponding arteries (see page 50).

### *Lymphatic*

The lymphatics of the lower vagina accompany those of the vulva to the inguinal nodes. The drainage of the upper vagina is the same as that of the cervix to the internal iliac (hypogastric), external iliac, obturator and sacral nodes (see page 51).

Innervation

See page 53.

UTERUS

General Description

The uterus is a thick-walled, muscular, hollow organ shaped like a pear, its tapering end being the cervix which projects into the upper vagina. The measurements were formerly given as 3 × 2 × 1 inch but these understate its size. Its dimensions vary but the nulliparous organ measures approximately 8 cm (3¼ inch) in overall length, 6 cm (2½ inch) across its widest part and 4 cm (1½ inch) from before backwards in its thickest part. It weighs 45-55 g. The wall is 1-2 cm thick, so the length of the normal uterine cavity, including the cervical canal, is not less than 7 cm and may be 7.5-8.0 cm.

The uterus is made up of a *body* or *corpus*, *isthmus* and *cervix*. The part of the body situated above the level of insertion of the fallopian tubes is described separately as *the fundus*, especially during pregnancy. The area of insertion of each fallopian tube is termed the *cornu*. The opening of the cervix into the vagina is the *external os uteri*.

The cavity of the uterus is triangular in shape when seen from the front (Fig. 2.13), but is no more than a slit when seen from the side (Fig. 2.12). It communicates with the vagina through the cervical canal, and with the lumen of each fallopian tube at the cornua.

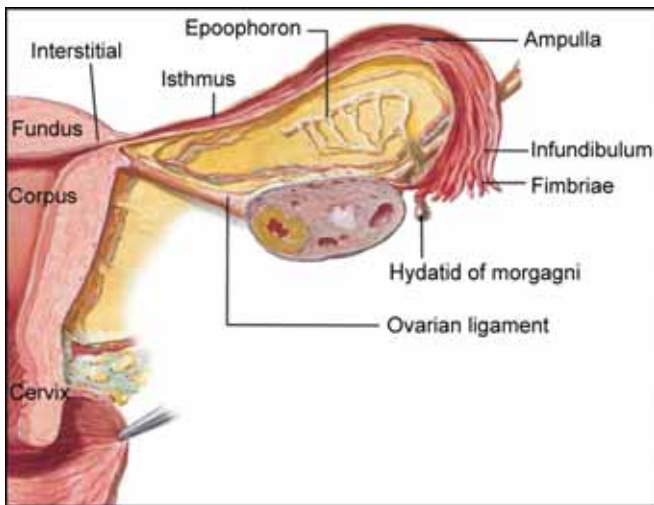


Fig. 2.13: The uterus and broad ligament from behind

Structure

The whole of the fundus, the anterior wall as low as the isthmus, and the posterior wall as low as the attachment of the vagina to the cervix are covered with peritoneum which is so intimately connected with the underlying muscle that it cannot be stripped away (Fig. 2.12). The sides of the uterus between the attachment of the two leaves of the broad ligament, the lower anterior uterine wall, and the whole of the cervix except for the posterior aspect of its supravaginal part, are devoid of peritoneum. The main mass of the wall is composed of involuntary muscle fibres which for the most part run obliquely in a criss-cross spiral fashion. The more superficial fibres, however, are arranged longitudinally and are continuous with those forming the outer coats of the tubes and vagina. Fibrous and elastic tissues are mixed with the muscle in varying amounts. Internal to the muscle layers is a mucous membrane which is directly applied to the muscle without an intervening submucosa, so its glands often dip into the fibro-muscular tissue.

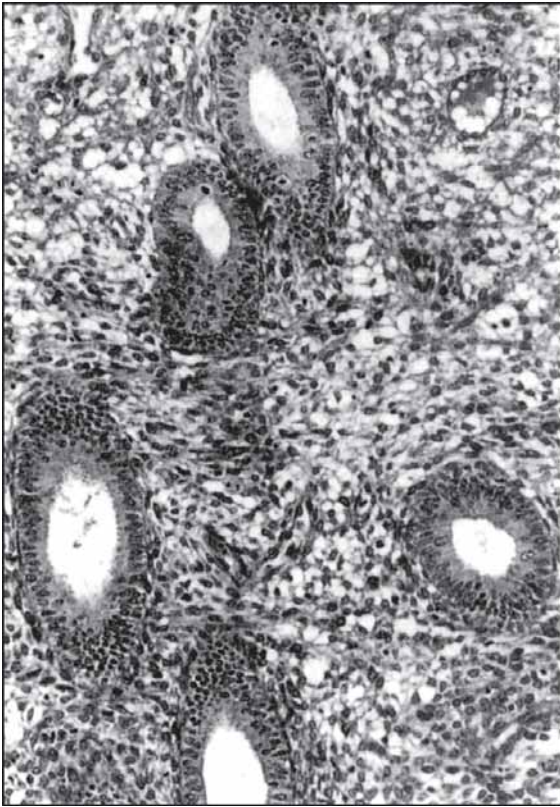
SPECIAL FEATURES OF EACH PART OF THE UTERUS

Corpus (Including Fundus)

The corpus makes up two-thirds or three-quarters of the uterus of the mature woman. The main muscle coat (*myometrium*) is lined by *endometrium* - a specialized form of mucous membrane. The latter varies in thickness from 1 to 10 mm according to the phase of the menstrual cycle. It is covered by a single layer of cuboidal or columnar epithelium which dips in to form simple unbranched tubular or spiral glands, some of which are so long that they extend from the surface to the myometrium. The epithelium is ciliated on the surface but not in the glands. The ciliae are lost once menstrual shedding starts at puberty. The glands lie in a stroma which is made up of loosely arranged immature connective tissue cells, amongst which can be seen blood vessels, lymphatics and leucocytes. Stromal cells are spindle- or star-shaped with little cytoplasm so, in microscopic sections, it is the darkly staining, small round or oval nuclei, rather than the cell outlines, which are seen (Fig. 2.14).

The endometrium and, to a lesser extent, the myometrium show cyclical histological and functional changes related to menstruation. These are described in Chapter 4.





**Fig. 2.14:** Endometrium in non-secretory (proliferative) phase. The glands are narrow and tubular, mitoses are present in both glands and stroma, and the stroma is immature. (Photomicrograph  $\times 180$ )

### Isthmus

The isthmus is an annular zone, no more than 0.1-0.5 cm from top to bottom in the non-pregnant uterus, which lies between the cervix and the corpus (Fig. 2.12). The obvious constriction between the uterine cavity and the cervical canal is the *anatomical internal os* and the isthmus is below this. The junction between the isthmus and the cervical canal proper, which is only recognised microscopically, is the *internal os*. The mucous membrane of the isthmus is intermediate in structure and function between that of the corpus and that of the cervix. The importance of the isthmus is that it is the area which, during late pregnancy and labour, becomes the lower uterine segment.

### Cervix

The cervix is barrel-shaped, measuring 2.5-3.5 cm from above downwards. Half of it projects into the vagina

(*vaginal cervix* or *portio vaginalis*) while half is above the vaginal attachment (*supravaginal cervix*) (Figs 2.12 and 2.13). The vaginal part is covered with squamous epithelium continuous with that of the vagina. The supravaginal part is surrounded by pelvic fascia except on its posterior aspect where it is covered with the peritoneum of the pouch of Douglas. A spindle-shaped canal, disposed centrally, connects the uterine cavity with the vagina. The upper part of the cervix is composed mainly of involuntary muscle, many of the fibres being continuous with those in the corpus. The lower half has a thin peripheral layer of muscle (the *external cervical muscle*) but is otherwise entirely composed of fibrous and collagenous tissues. The mucous membrane lining the canal (*endocervix*) is thrown into folds which consist of anterior and posterior columns from which radiate circumferential folds to give the appearance of tree trunk and branches, hence the name *arbor vitae* (Fig. 2.15). This arrangement is most obvious in the young nullipara in whom the irregularity of surface can make the passage of a sound difficult. Histologically the endocervix differs considerably from the endometrium. It is covered by a single layer of tall columnar epithelial cells which, on



**Fig. 2.15:** The arbor vitae in the cervix. The specimen otherwise shows generalized hypertrophy of the uterus which was associated with pelvic adhesions and which resulted in menorrhagia

the tops of the folds but not in the crypts and glands, are ciliated. Beneath this is a layer of more cubical 'basal' or 'reserve' cells from which new surface cells are believed to develop and undergo squamous metaplasia. The surface epithelium dips down to form complicated glands and crypts which number approximately 100. They penetrate the fibromuscular tissue and lie in a stroma more fibrous and dense than that of the endometrium. The epithelium of these glands is taller than that of endometrial glands and the nuclei are always basal in position (Fig. 2.9). The acini secrete an alkaline (pH 7.8) mucus, a gel rich in mucoproteins, mucopolysaccharides and fructose, the last having a nutritive function for spermatozoa. The physical and chemical properties of cervical mucus vary with the time in the menstrual cycle and with pregnancy.

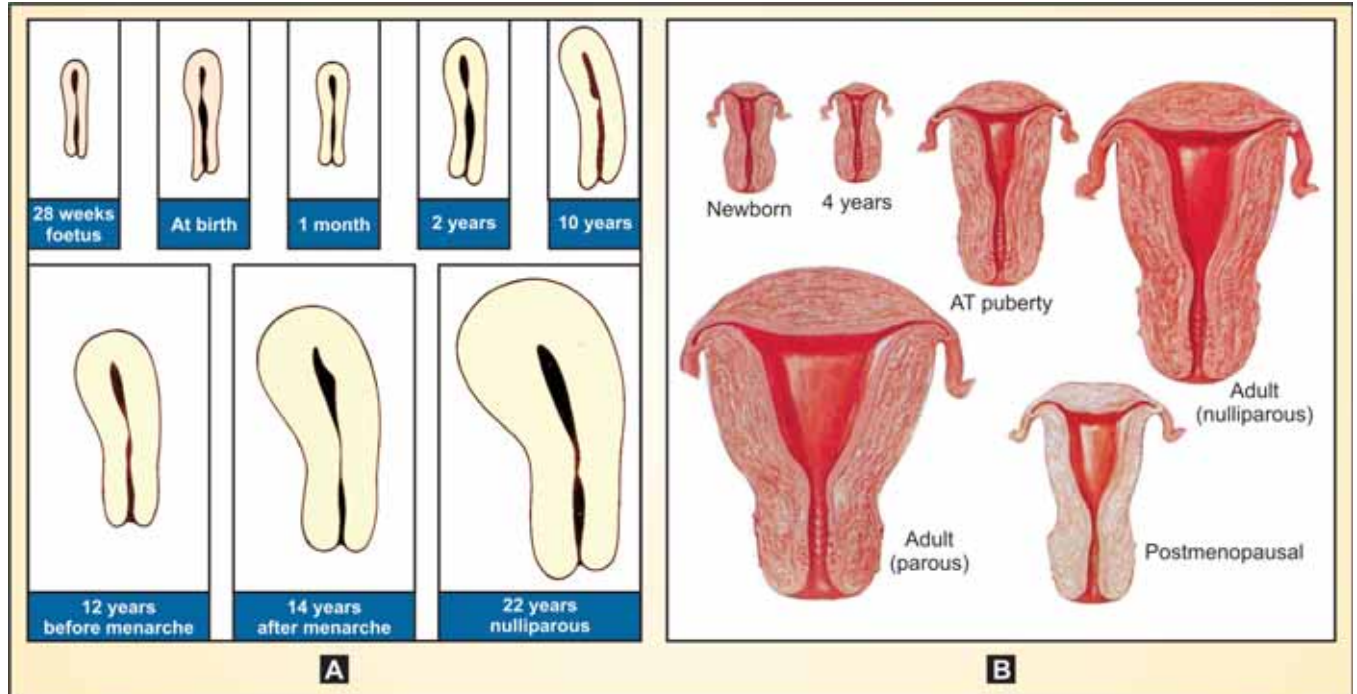
Cervical mucus is an important constituent of the normal vaginal discharge but some of it lies in the cervical canal to form a 'plug' which provides functional closure of the cervix. This plug prevents vaginal bacteria from invading the uterus by its mechanical and, probably, bacteriolytic properties. The junction of the

squamous epithelium covering the vaginal cervix and the columnar epithelium of the endocervix is normally situated at the external os. It is usually sharply defined by an abrupt change in cellular type but there may be a transitional zone 1-10 mm in width with variable histological features (Figs 2.8 and 2.9).

*Changes in the Uterus with Age and Parity*

In childhood the cervix is longer than the corpus uteri, the proportions being 2:1. At one stage in intrauterine development the proportions are 5:1 or 6:1 (Figs 2.16A and B). At and after puberty, however, the corpus grows faster than the cervix and the latter represents only one-third of the total length of the mature uterus; indeed, it is sometimes only one-quarter of the parous uterus. After the climacteric the uterus atrophies, its overall length is reduced and its walls become thinner, less muscular, and more fibrous. The cervix shrinks so the vaginal portion no longer projects and the external os becomes more or less flush with the vaginal wall.

In infancy, the epithelium covering the vaginal cervix and the adjacent vaginal walls lies in folds to give it a



**Figs 2.16A and B:** The relative sizes of the uterus at different ages. The size at birth is greater than in a child aged one month because of the effect of oestrogen circulating in the foetus *in utero*. Note also that the length of the cervix in relation to that of the corpus diminishes with increasing development, and anteflexion of the uterus only appears at puberty

puckered appearance. The endometrium and endocervix are thin and inactive, with only a few small superficial glands. Their development at puberty and subsequent cyclical behaviour during the reproductive age are described in Chapters 4 and 12. In old age, both the endometrium and the endocervix become grossly atrophic; their glands are sparse and inactive.

The uterus hypertrophies during pregnancy and involutes afterwards, but never returns completely to its former state. The body of the uterus remains somewhat larger and its structure is slightly modified in that elastic tissue, deposited in and around blood vessels during pregnancy, is not reabsorbed. The amount of elastic tissue found in any myometrium is therefore proportional to the number of pregnancies previously experienced. Repeated childbearing and advancing years may also lead to a relative increase of fibrous tissue in the myometrium and a consequent increased risk of spontaneous rupture of the uterus during labour.

The cervix is modified by childbearing because, during its dilatation in labour, it always suffers some degree of tearing and injury. The nulliparous external os is circular in shape and gives to the examining finger the same sensation as that obtained by feeling the tip of a nose. The multiparous external os appears as a transverse slit and feels somewhat similar to pursed lips.

#### *The Position of the Uterus*

When viewed from the side, the adult uterus is bent forwards on itself in an attitude of *anteflexion* (Fig. 17.2). The bend is situated about the level of the internal os.

In addition, the axis of the cervix is inclined forwards at an angle of approximately 90 degrees to the axis of the vagina, giving rise to a state of *anteversion*; when a woman is standing, the cavity of the uterus is therefore more horizontal than vertical. Version and flexion are not always in the forward direction and approximately 15 per cent of women have uteri which are retroverted or retroflexed or both; such states are not usually pathological (see Chapter 17).

The uterus is normally moderately mobile, its most fixed part being the supravaginal cervix where the strong supporting ligaments are attached. The fundus can therefore rotate round this point, and the degree of anteflexion and anteversion is influenced by the state of adjacent organs. Thus, a full bladder rotates the uterus backwards and also reduces anteflexion.

The height of the uterus in the pelvis varies with posture and other factors (see Chapter 17) but, in the standing woman, the internal os is approximately level with the upper border of the symphysis pubis and the external os is opposite the tip of the ischial spine. It follows that the body of the uterus lies normally above the level of the symphysis pubis so, in the thin woman with relaxed abdominal muscles and an empty bladder, it is possible to feel it on abdominal examination.

#### *The Supports of the Uterus*

See page 47.

### The Relations of the Uterus

#### *Anterior*

The upper part of the uterus has the uterovesical pouch and either intestines or bladder in front of it. The lower part is closely associated with the base of the bladder from which it is separated only by loose connective tissue.

#### *Posterior*

Posteriorly lies the pouch of Douglas (uterorectal pouch) with coils of intestine. The vaginal cervix also has the posterior fornix behind it.

#### *Lateral*

Laterally is the broad ligament and its contents, especially the uterine artery which runs up the side of the uterus, giving off branches at different levels. As it passes forward to reach the base of the bladder the ureter lies only 1-2 cm to the side of the supravaginal cervix - an extremely important point for the surgeon (Fig. 2.17).

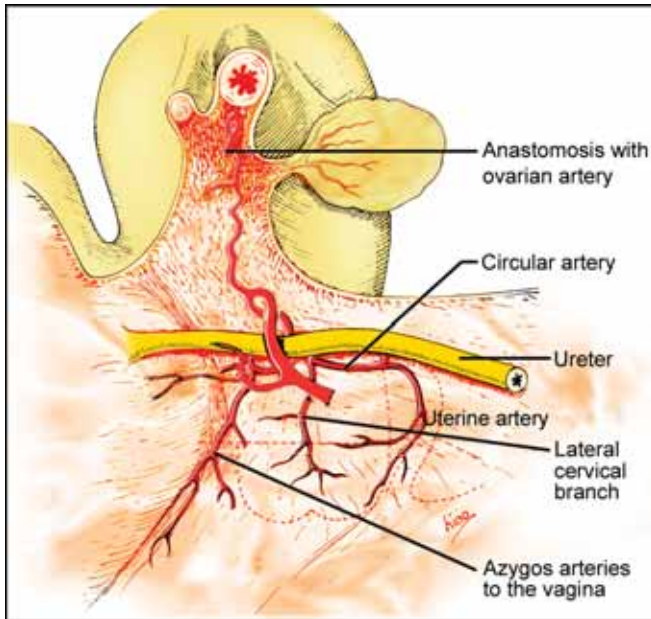
## VASCULAR CONNECTIONS

### Arterial

- Uterine artery
- Ovarian artery

### Venous

- Pampiniform plexus in broad ligament
- Uterine vein
- Ovarian vein
- Vaginal plexus
- Vertebral plexus



**Fig. 2.17:** The broad ligament from the side showing the relation of the ureter to the uterine artery, and how the latter supplies branches to the corpus, cervix and vagina

## Lymphatic

### Cervix

- Paracervical plexus
- Obturator nodes
- External iliac and internal iliac (hypogastric) nodes
- Sacral nodes

### Corpus

The same as the cervix. Also the aortic nodes (via lymphatics accompanying the ovarian vessels) and the superficial inguinal nodes (via lymphatics in the round ligament) (*See also* pages 47 and 51).

### Innervation

*See* page 53.

## FALLOPIAN TUBES

### General Description

The two fallopian tubes are oviducts which extend from the ovaries to the cornua of the uterus, one on either side.

They are somewhat tortuous and their outer parts curve backwards (Fig. 2.10). Each lies in the free upper border of the broad ligament and, when straightened, is 10 cm in length. Its lumen communicates with the uterine cavity at its inner end and with the peritoneal cavity at its outer, and thus provides the final section of an open, or potentially open, canal which leads from the exterior to the abdominal cavity.

The fallopian tube is divided into four parts (Fig. 2.13) as follows:

### *Interstitial or Intramural Part*

This is only 1-2 cm in length and is the part which traverses the uterine wall. It has a very narrow lumen (1 mm in diameter) and is different from the remainder of the tube in that it is without a peritoneal coat, and in that the outer longitudinal muscle has disappeared to cover the uterus.

### *Isthmus*

This is the straight and narrow portion adjacent to the uterus and measures 2-3 cm. It has thick walls but the lumen is so narrow that it will only admit the finest probe (1-2 mm in diameter).

### *Ampulla*

This is the wider, thin-walled and tortuous outer portion, approximately 5 cm in length, which leads to the infundibulum.

### *Infundibulum*

This is the trumpet-shaped outer end with an opening into the peritoneal cavity (*abdominal ostium*). The latter is surrounded by fronds or *fimbriae*, one of which is longer than the others and is directed towards the ovary (*fimbria ovarica*). The fimbriated extremity is free of the broad ligament and curls back on itself so that its fimbriae aim to embrace the ovary like the tentacles of an octopus; this is important to fertility.

## Structure

Except for a narrow strip opposite to its attachment to the broad ligament, the extrauterine part of the fallopian tube is covered with peritoneum. Beneath this are an outer longitudinal layer and an inner circular layer of

involuntary muscle. The muscle zone is thick at the isthmus and thin at the ampulla. It is separated from the mucosa lining the lumen (*endosalpinx*) by a delicate connective tissue submucosa. The mucous membrane is arranged in the interstitial and isthmic portions of the tube in four or five main longitudinal ridges, but these develop subsidiary folds or plicae to form a very complicated arborescence in the ampullary portion. It is lined by columnar epithelium supported by a thin stroma (Figs 2.18 and 2.19). About half the epithelial cells, especially in the outer parts of the tube, are ciliated and create a current. This, combined with peristaltic action of the muscle, propels the ovum towards the uterus.

This is in accord with the general view that the peristaltic wave is towards the uterus. Yet observations on the tube *in situ* indicate that the contraction wave is variable and sometimes in reverse. Most of the other epithelial cells have a secretory function, which is achieved by cytoplasmic and nuclear extrusion. The resulting product is a serous fluid, rich in protein, which may be nutritive to the fertilized ovum. A third type of epithelial cell is 'peg-shaped'; its function is doubtful and it may represent an immature or senile form of the others. Another suggestion is that the 'peg' cell is merely a secretory (goblet) cell which has discharged its secretion.

Both the muscular and secretory activities of the tube are under the influence of ovarian hormones and therefore show cyclical changes during the menstrual life of a woman. Before puberty and after the menopause the tube is functionally quiet.



**Fig. 2.18:** Photomicrograph showing the mucosa of the fallopian tube and one of its folds

## Relations

### *Superior*

Above the fallopian tubes lie coils of intestine and the omentum, with the appendix and caecum on the right side and the pelvic colon on the left.

### *Inferior*

The broad ligament and its contents, and particularly the mesosalpinx with the epoophoron, paroophoron and Gartner's duct (Figs 2.13 and 2.20) lie below. So do the ovary and mesovarium, but on a more posterior plane.

### *Posterior*

Behind the fallopian tubes are the ovaries and the uterorectal pouch with its contents.

### *Anterior*

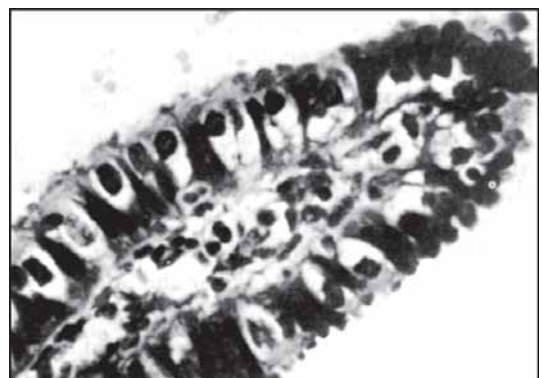
To the front lie the top of the bladder and the uterovesical pouch.

### *Lateral*

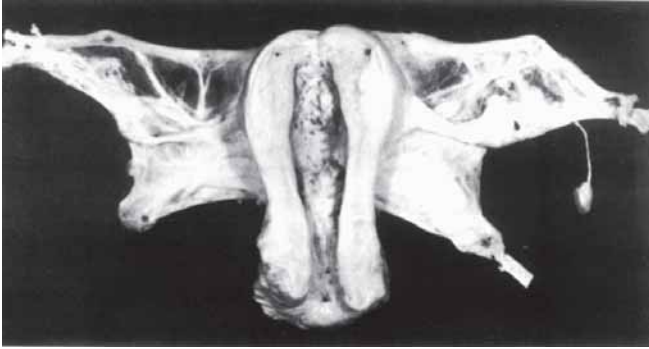
On either side is the lateral pelvic wall with the structures thereon.

## Vascular Connections and Innervation

The vascular connections and innervation are similar to those of the ovary (*see* pages 47-55).



**Fig. 2.19:** A higher magnification of the endosalpinx showing ciliated cells, secretory cells and 'peg' cells. The secretory cells have globules of secretion within their cytoplasm (*see text*)



**Fig. 2.20:** Gartner's duct and other vestigial structures in the broad ligament. These are easily seen because the specimen was obtained from a senile woman in whom the fat and the connective tissue of the broad ligament had atrophied. The ovaries are equally atrophic. The structures can be identified by comparison with Fig. 2.13. The dependent small cyst on the right is the hydatid of Morgagni. The fundus of the uterus contains an early endometrial carcinoma

## OVARY

### General Description

The two ovaries are mainly solid ovoid structures, approximately 3.5 cm in length and 1.5-2.5 cm in thickness. Each weighs 4-8 g, the right tending to be larger than the left. They are attached to the back of the broad ligament by the mesovarium, one on either side of the uterus (Fig. 2.13). Each is suspended from the cornu of the uterus by an ovarian ligament. The surface of the adult active ovary is corrugated, and is pale except where there happens to be some structure such as a corpus luteum. *The ovary is the only organ in the abdomen which is not covered by peritoneum.* The part of the ovary attached to the mesovarium is the *hilum* and all nerves and vessels enter and leave at this point. In the hilum and adjacent mesovarium are small collections of *hilus cells* which may be homologous to the interstitial cells of the testis.

### Structure

The ovary is said to have a *cortex* (outer zone) and *medulla* (inner zone) but these are not clearly defined. Both areas have a connective tissue stroma in which can be found blood vessels, nerves, and graafian follicles in varying stages of development together with their derivatives,

the corpora lutea and corpora albicantia (see Chapter 3). Primordial follicles are mostly found in the cortex, the medulla is more vascular and contains spiral vessels (Fig. 2.30). The cortex is covered with *germinal epithelium* which consists of a single layer of low cuboidal cells but is only seen in early life. Later, the ovary is coated only by the connective tissue *tunica albuginea*. It is now recognized that the germinal epithelium does not give rise to germ cells, so many prefer to call it *surface epithelium*.

The tunica albuginea is not well developed and not as resistant as the comparable structure in the testis. So distension of the ovary by ripening follicles or by pathological states does not cause pain. Even when the tunica is unusually thick, as in the polycystic ovary syndrome, it does not prevent ovulation.

### Relations

These are similar to those of the fallopian tube. Indeed, the tube and ovary and their mesenteries are so closely related anatomically that they are often collectively called the *adnexum* (plural = adnexa). The exact position of the ovary and tube varies considerably; they are sometimes near the pelvic brim, at other times in the uterorectal pouch.

The ovary usually lies against the lateral wall of the pelvis in a depression called the ovarian fossa. The fossa is bounded by the external iliac vessels above and by the internal iliac vessels and the ureter behind. The obturator nerve crosses the floor of the fossa.

### Changes with Age and Parity

In infancy and childhood the ovary is a tiny elongated structure with a smooth surface, situated near the pelvic brim, and packed with primary oocytes. Although in the newborn baby it may show small follicular cysts resulting from the stimulation by chorionic gonadotrophins, it later contains only primordial or atretic follicles.

After the menopause the ovary becomes smaller in size and shrivelled in appearance; these changes are the results of atrophy of the medulla, and not of scarring following repeated ovulation as is sometimes stated. At a later stage the surface becomes smooth again as in childhood. No follicles are found in old age. The spiral shape of the arterioles in the medulla is seen only in the reproductive years and appears to be controlled by oestrogen.

## Vascular Connections

### Arterial (see page 47)

- Ovarian artery
- Uterine artery

### Venous (see page 50)

- Pampiniform plexus
- Ovarian vein
- Uterine vein

### Lymphatic (see page 51)

- Aortic nodes (via lymphatics accompanying the ovarian vessels)
- External iliac nodes

### Innervation

See page 53.

## URETHRA AND BLADDER

### General Description

The external urinary meatus is in the vestibule, outside the hymen, and enclosed by the foreparts of the labia minora. The urethra itself runs upwards and backwards, being partly incorporated in the anterior vaginal wall. It is short and straight, measuring only 2-4 cm in length. It joins the bladder base to form what appear on radiographic silhouettes as clearly defined angles. These are present in both lateral and anteroposterior views and there is no such thing as a 'bladder neck' in the female (Figs 2.6, 2.7 and 2.21A to F). On the floor of the urethra at its lower end are tiny openings of *Skene's tubules which drain two small collections of periurethral or paraurethral glands*. These are rudimentary structures homologous to the prostate in the male. They resemble this organ in that they are sites for chronic infection.

The bladder is a hollow muscular organ with a capacity of 300-600 ml but with such powers of distension that, in conditions of prolonged retention, it can accommodate several litres of fluid. The base of the full bladder is comparatively flat and, when viewed from the side, occupies a plane which runs from the middle of the back of the symphysis pubis to the fourth sacral vertebra (Figs 2.6, 2.7 and 2.21A to F). The shape and position of the fundus of the bladder vary with the volume of the contents; the top can extend as high as the umbilicus (see Fig. 17.4).

The ureters enter the bladder on the posterior aspect of its base, piercing the bladder wall obliquely, one on either side of the middle line. The obliquity acts as a valve in that it prevents reflux of urine into the ureter when the bladder is full. The ridge joining the internal orifices is the *interureteric (Mercier's) bar*, and the smooth triangular area bounded by the ureteric openings and the internal urethral meatus is the *trigone*.

### Structure

Only the fundus of the bladder has a peritoneal covering. Elsewhere the muscle is coated with fascia only.

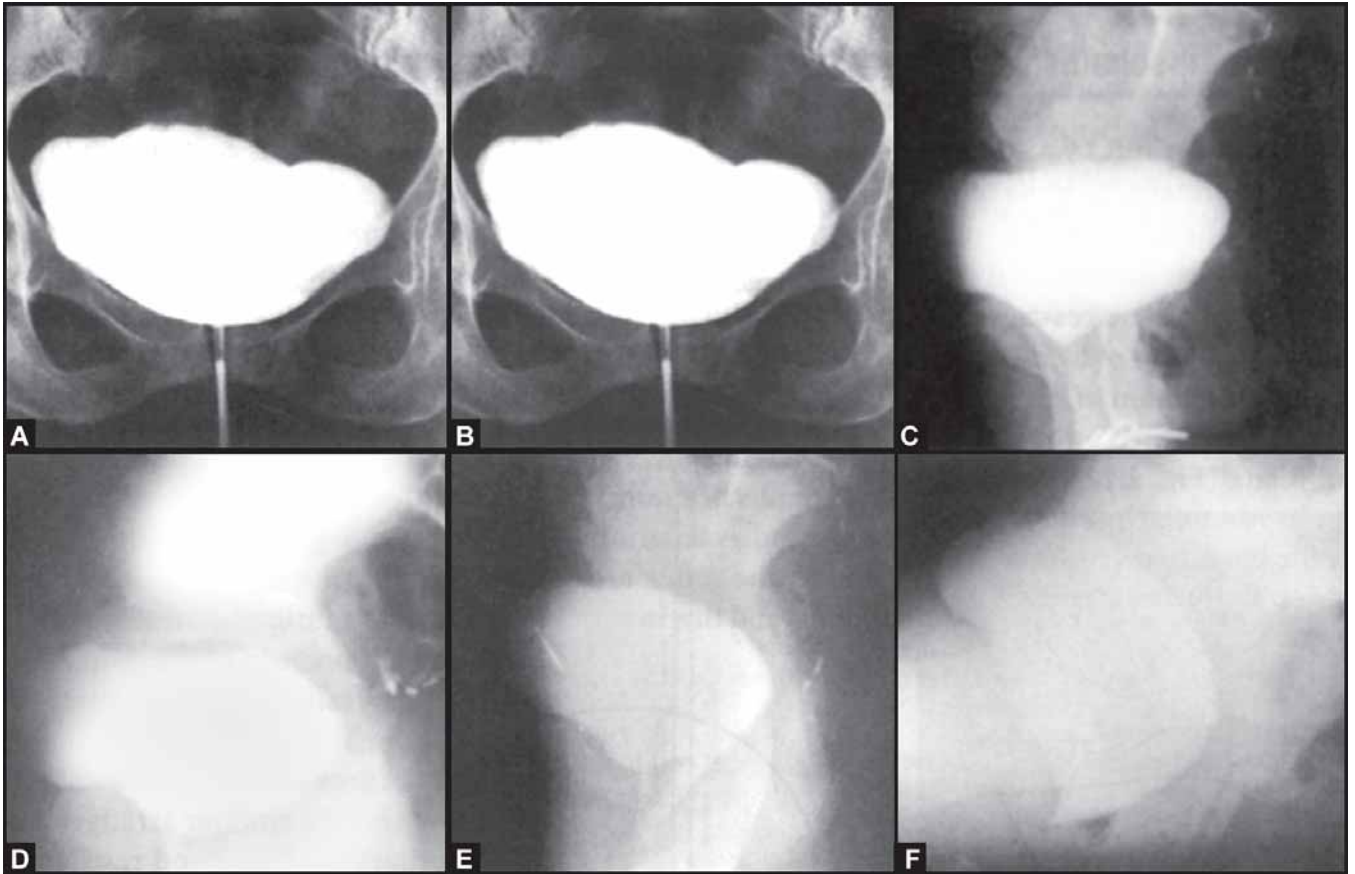
Except for the external meatus, which has true stratified epithelium, the bladder and urethra are lined by transitional epithelium which is responsive to ovarian hormones and which is supported by a thin layer of connective tissue. Beneath this is a complicated pattern of involuntary muscle which is continued from the bladder into the urethra. An intricate decussation at the urethrovesical junction has the effect of forming anterior and posterior slings which function as an *internal sphincter* (Fig. 2.22). The muscle of the trigone is an insignificant structure in women.

The wall of the urethra is made up entirely of involuntary muscle, the fibres of which are mainly disposed in the form of crossed spirals. When these are closely coiled they have a circular arrangement which provides good urethral tone and resistance. When they are drawn out their resistance is lowered and the urethra can dilate (Fig. 2.22). Indeed, the bladder and urethra have a polarity similar to that of the uterus; when the bladder detrusor contracts, it opens the urethra from above downwards by pulling on the spiral framework.

The urethra itself is devoid of true anatomical sphincters but the tone and elasticity of its involuntary muscles keep it closed except during micturition. Where it pierces the triangular ligament, approximately 1 cm from its lower end, it is encompassed by the voluntary compressor urethrae which is sometimes called the *external sphincter*. The urethra probably does not receive voluntary fibres from the levatores ani, as is sometimes suggested; the inner parts of the puborectalis pass well to the side to be inserted into the vagina (Fig. 2.25).

### Sphincter Mechanism

As the bladder fills by a succession of drops of urine from the ureters, its walls retreat to keep a constant muscle

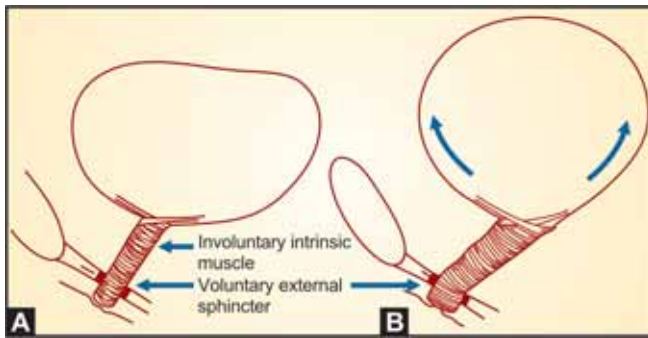


**Figs 2.21A to F:** The anatomy and function of the bladder and urethra as revealed by lateral urethrocytography. (By permission of Mr H. Robert and the Editor, *J Obstet Gynaecol Br Emp*) (A) Normal nulliparous woman at ease with the bladder made radio-opaque with a solution of sodium iodide. The urethra is outlined by a soft and pliable catheter filled with radio-opaque fluid, (B) Normal nulliparous woman resting easily, anteroposterior view; what appears to be the urethrovesical junction is not so because, as shown in (a), this is at a higher level than part of the bladder base, (C) Normal nulliparous woman raising her intravesical pressure by bearing down; there is no change in the anatomy of the urethrovesical junction, (D) Commencing voiding. The catheter has been removed and the urethra is opening from above downwards, the floor of the urethra coming into line with the trigone of the bladder (disappearance of the posterior urethrovesical angle). This reflects opening of the internal urethral sphincter brought about by contraction of the bladder detrusor muscle which is manifested by the crenated outline of the posterior bladder wall, (E) Voiding is now well established. The urethra is dilated, the 'posterior angle' is obliterated and the bladder base and upper urethra have rotated slightly backwards and downwards. Active contraction of the bladder is indicated by its ovoid shape and fluffy outline, (F) Micturition inhibited by voluntary contraction of the external urethral sphincter (compressor urethrae). The bladder is still contracting but the woman has shut off the stream at the lower end of the urethra

tone so that the intravesical pressure is maintained at less than 10 cm of water (*see* Fig. 52.3). When the volume reaches 200-300 ml, a desire to void is induced, not by increased intravesical pressure but by stimulation of stretch receptors in the bladder wall. In untrained animals and children this sets in motion a reflex involving spinal roots S2, S3 and S4, which results in automatic contraction of the detrusor muscle and

evacuation of the bladder. In the adult, however, the reflex arc is subservient to the hypo-thalamus and this in turn to higher areas of the brain, notably the anterior parts of the frontal lobes (Fig. 2.23). Action of the detrusor muscle can therefore be voluntarily inhibited and the urge resisted until it is convenient to void. When this happens the bladder distends further, but there is still no appreciable rise in the intravesical pressure until the



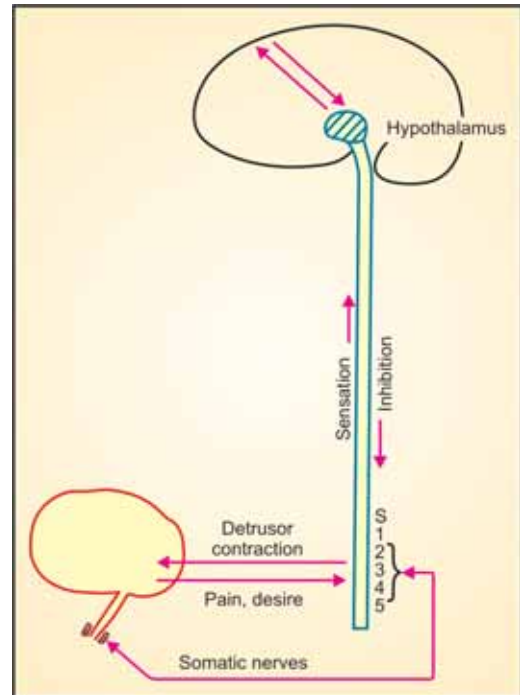


**Fig. 2.22:** The involuntary intrinsic muscle in the urethra is distributed in the form of crossed spirals, the fibres being continuous with those of the bladder detrusor. Their decussation at the urethrovesical junction, with a suggestion of the formation of slings, constitutes the internal urethral sphincter. The external voluntary sphincter lies outside the intrinsic muscle, between the layers of the urogenital diaphragm, (A) Detrusor inactive so the spirals in the urethra are closely coiled to bring the walls in apposition, (B) When the detrusor muscle contracts, as in voiding, the spirals in the urethra are pulled out with consequent loss of resistance. The urethra then opens from above downwards, the trigone coming into line with the floor of the urethra

limit of bladder capacity is approached (Fig. 52.3). The slight increase at that time is the result of the detrusor escaping from inhibition and is accompanied by an intense and irresistible urge to void.

During micturition the pressure rises to 30 or 50 cm of water as the result of the contraction of the bladder wall, and can be raised to a total of 100 cm of water by voluntary contraction of the abdominal muscles. Except during micturition, the urethra is always empty, even if the intravesical pressure is raised to 50 or 70 cm of water by coughing or other strong effort (Fig. 52.3). Continence is therefore normally maintained at the urethrovesical junction, by the involuntary internal sphincter. This fundamental fact explains why a urethrovaginal fistula, unless it involves the uppermost part of the urethra, does not result in incontinence of urine; neither does surgical removal of the lower half of the urethra.

The urethral resistance as a whole, which is offered by the inherent tone and elasticity of the intrinsic involuntary muscle, provides a second, although not very efficient, line of defence when a weak internal sphincter allows urine to enter the lumen. The compressor urethrae enables a woman voluntarily to arrest the flow of urine, even during voiding, and its action can be demonstrated radiologically (Figs 2.21f and

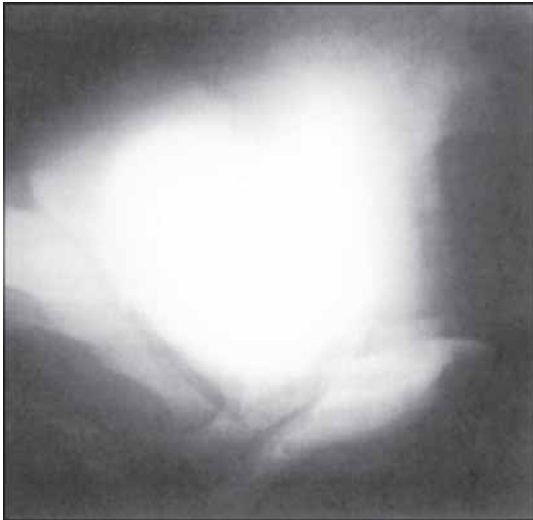


**Fig. 2.23:** The nervous control of bladder filling and emptying. Stretch receptors in the bladder wall transmit sensation of fullness to the spinal cord. A basic reflex then provides for stimulation of the involuntary detrusor muscle of the bladder to produce automatic emptying. This reflex is controlled in trained animals by central inhibition, the centres involved being the cortex and the hypothalamus. The external sphincter is voluntarily controlled by the central nervous system

2.24). It can always be brought into play in an emergency. Otherwise, the action of these urethral and periurethral muscles is to empty the urethra at the conclusion of micturition.

The process of micturition is illustrated in Figures 2.7 and 2.21 and is as follows:

- Bearing-down effort accompanied by relaxation of the pelvic diaphragm.
- Descent of the bladder base with rotation of the upper urethra around a fixed point at the triangular ligament.
- Contraction of the detrusor muscle now released from inhibition.
- Dilatation of the urethra from above downwards.
- The characteristic feature of opening of the internal sphincter, as seen on lateral radiographs, is the coming into line of the trigone and the floor of the



**Fig. 2.24:** The voluntary arrest of micturition shown by a double exposure of the same film. The vagina as well as the bladder contains radio-opaque material. The fainter shadows illustrate the situation during voiding: the deeper ones the effect of deliberate stoppage of the act. The flow down the urethra is arrested by the external sphincter and the urethra then closes from below upwards returning to the bladder any fluid within it

urethra. This results in the radiological sign of 'disappearance of the posterior urethrovesical angle', the 'anterior angle' being maintained.

- During voiding, and especially if the woman under study is nervous, detrusor activity can be intermittent and this shows by periodic partial closure of the internal sphincter with consequent periodic partial restoration of the posterior angle.
- At the end of micturition the urethra closes from below upwards and any remaining drops of urine are returned to the bladder.

A fundamental radiographic sign of a relaxed internal sphincter, during voiding or in other circumstances, is the obliteration of the posterior urethrovesical angle. The mechanism whereby this is achieved is dependent on the action of the involuntary muscle of the bladder and of the urethrovesical junction. It is *not* dependent on relaxation of the levatores ani.

### Relations of the Urethra and Bladder

#### Posterior

Behind the urethra are Skene's tubules and the vaginal wall but no intervening fascia. The base of the bladder is

separated from the upper anterior vaginal wall by the pubocervical fascia. Above this the bladder comes into relation with the supravaginal cervix, the isthmus of the uterus, and the uterovesical pouch of peritoneum containing intestine.

#### Anterior

In front of the urethra and bladder, and separating them from the pubic bones and their ligaments, is the loose cellular tissue of the space of Retzius with venous plexuses marking the urethrovesical junction. Above this level the full bladder comes into direct contact with the muscles of the anterior abdominal wall.

#### Lateral

The urethra has on either side the bulbospongiosus muscle, the vestibular bulb, the compressor urethrae, the urogenital diaphragm and its contents, and the inferior pubic ramus. The levator ani muscle (pubo-rectalis) is a lateral relation as it sweeps backwards to be inserted partly into the side of the vagina (Fig. 2.25). The tendinous foreparts of this muscle also lie below and to the side of the bladder.

### Vascular Connections

#### Arterial

- Bladder  
Superior and inferior vesical arteries from the internal iliac artery
- Urethra  
Inferior vesical artery and branches of the internal pudendal artery.

#### Venous

Vesical and vaginal plexuses and hence to the internal iliac veins.

#### Lymphatic

Lymphatics accompany blood vessels to the internal iliac (hypogastric) and external iliac nodes. The external urethral meatus drains with the vulva to the inguinal nodes (*See* page 51).

#### Innervation

*See* page 53 and Fig. 2.23.

## URETER

### General Description

The ureter is lined by transitional epithelium and its main coat consist of involuntary muscle which has a peristaltic action to propel urine from the kidney to the bladder. It lies behind the peritoneum but is closely adherent to it. In its pelvic course the ureter has such close relations to the genital organs that it may be obstructed by their diseases and is always at risk during operations on them. It has been cynically stated that no one is a gynaecologist until he or she has cut a ureter unintentionally.

### Relations

As it enters the pelvis the ureter lies anterior to the sacroiliac joint although separated from it by muscles, ligaments and the common iliac artery and vein. It crosses in front of these vessels at the point where they bifurcate into external and internal branches, and then turns downward into the pelvis, running along the front of the internal iliac artery but on the medial side of the branches of this artery. At the pelvic brim the ureter is in relation to the ovarian vessels which cross it anteriorly and, on the left side, to the pelvic mesocolon and its vessels (Fig. 2.28).

In the true pelvis it turns inwards and forwards towards the bladder, running lateral to the uterosacral ligament. It crosses the base of the broad ligament lying below and at right angles to the uterine artery (Fig. 2.17). In the latter part of its course the ureter lies 1 cm to the side of the supravaginal cervix and 1 cm above the lateral vaginal fornix. At this point it pierces the cardinal ligament of the uterus which is condensed around to form the *ureteric canal*.

The ureter is most exposed to surgical injury: at the pelvic brim when the ovarian vessels are ligated; during division and ligature of the lower part of the broad ligament; during removal of broad ligament which displace it from its normal position; during peritonization of the pelvis when, being adherent to the posterior leaf, it may be included in a suture; and when the cardinal ligaments are tightened to cure uterine prolapse.

About 75 per cent of all iatrogenic injuries to the ureter result from gynaecologic procedures, most commonly abdominal hysterectomy. Distortions of pelvic anatomy, including adnexal masses, endometriosis, other pelvic adhesive disease, or fibroids, may increase susceptibility to injury by displacement or alteration of usual anatomy.

Even with severe intraperitoneal disease, however, the ureter can always be identified using a retroperitoneal approach and noting fundamental landmarks and relationships.

### Vascular Connections

#### Arterial

Special branches from:

- Renal artery
- Ovarian artery
- Internal iliac or common iliac artery
- Uterine artery
- Inferior vesical artery

#### Venous

- Veins accompanying arteries

#### Lymphatic

- Para-aortic nodes
- Internal iliac nodes

Interference with all the arterial supplies, or stripping of the outer vascular coat, such as may occur during extensive pelvic operations, results in ischaemic necrosis of the ureter with consequent fistula formation.

## SIGMOID COLON

### General Description

The sigmoid (pelvic) colon is the continuation of the descending colon, the arbitrary dividing line being the brim of the true pelvis. Although attached to the left side of the pelvis by a mesentery, it lies in loops behind the broad ligament. Its length varies but averages 40 cm, and it terminates in the rectum at the level of the third piece of the sacrum. The mesentery is longest where the colon loops but is short at its upper and lower ends.

### Structure

Except for the narrow line of its attachment to its mesentery, where the blood vessels, lymphatics and nerves join it, the pelvic colon is completely surrounded by peritoneum. This serous coat is thrown into a number of small pouches containing fat - the *appendices epiploicae*. Beneath it is the wall of involuntary muscle which is arranged in outer longitudinal, and inner circular, layers.

Within this, and separated by areolar tissue, is the inner lining of mucous membrane. The latter is covered by a single layer of non-ciliated columnar cells. These dip down in the form of simple tubules to form glands which secrete mucus and also absorb fluid.

## Relations

### *Anterior*

These are mainly the broad ligament and all the organs associated with it, including the uterus.

### *Posterior*

Behind and to the left lie the rectum, the posterior and left walls of the pelvis, together with the retroperitoneal structures. The latter include the left common and external iliac vessels, the left ureter, the left sacral plexus and pyriformis muscle.

## Vascular Connections

### *Arterial*

- Inferior mesenteric artery
- Left colic artery.

### *Venous*

- Veins corresponding to arteries.

### *Lymphatic*

- Preaortic nodes around the origins of the inferior mesenteric vessels.

### *Innervation*

This is entirely autonomic by way of parasympathetic nerves from the preaortic plexuses. These are motor and sensory and accompany blood vessels.

## RECTUM AND ANUS

### General Description

The importance of the rectum and anus lies in their close proximity to the genital organs, and their consequent involvement in the same diseases and in injuries during childbirth and gynaecological operations. The rectum commences at the level of the third piece of the sacrum and is 12-15 cm in length. It curves twice on the left and

once to the right as it passes down to end in the anal canal which is approximately 2-3 cm in length. The ampulla bulges forward against the posterior vaginal wall and the anal canal is directed backwards, almost at right angles to the ampulla (Fig. 2.7). This angulation is at the site of the insertion of fibres of the puborectalis muscle.

### Structure

Only the anterior and lateral aspects of the upper rectum are covered with peritoneum. Beneath this are the outer longitudinal and inner circular muscle coats. The lining is mucus-secreting tall columnar epithelium with a complicated glandular pattern, except for the lowermost part of the anal canal which has a stratified squamous covering continuous with the skin. The mucous membrane is exuberant and ridged and is also raised to form the three valves of Houston.

The anal canal has internal (involuntary) and external (voluntary) sphincters but its control is also dependent on the levatores ani, the inner parts of which surround it and are inserted into its outer wall (Figs 2.25 and 2.26).

### Relations

#### *Anterior*

In front of the upper part of the rectum lies the uterorectal pouch of peritoneum which often contains loops of small or large bowel. Anterior to this is the uterus with the broad ligaments and adnexa. Below the pelvic peritoneum the anterior wall of the rectum comes into close association with the middle part of the posterior vaginal wall, being separated from it only by rectovaginal fascia and connective tissues. Interposed between the anal canal and lower vagina is the perineal body.

#### *Posterior*

Behind the rectum are loose connective tissue, sacral nerve trunks, the middle sacral vessels, the sacrum and the coccyx.

#### *Lateral*

On either side are the uterosacral ligament, the pelvic plexus of autonomic nerves and the ureter. At a lower level is the levator ani muscle, which is in part inserted into the rectum and anus (Figs 2.25 and 2.26). Below and

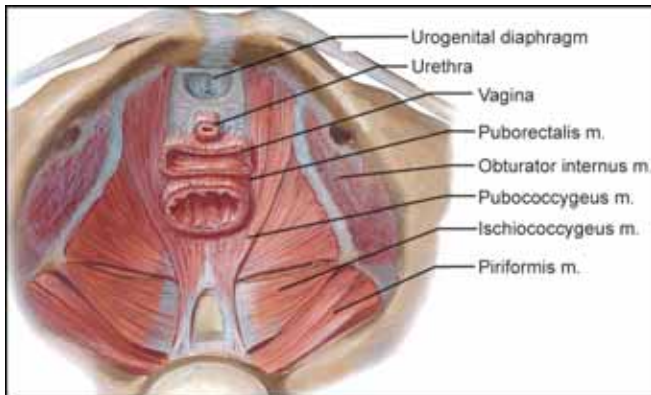


Fig. 2.25: The levatores ani muscles from above

lateral to this muscle are the fat and areolar tissue of the ischiorectal fossa.

### Vascular Connections

#### Arterial

- Superior rectal branch of the inferior mesenteric artery
- Middle rectal branch of the internal iliac artery
- Inferior rectal branch of the pudendal artery.

#### Venous

Veins accompanying arteries, the superior rectal draining to the portal circulation. The junction of the portal and systemic venous drainages in the anal canal marks the site of haemorrhoid formation.

#### Lymphatic

- Internal iliac nodes mainly, also sacral and para-aortic
- Superficial inguinal nodes (anus only).

#### Innervation

The anus and voluntary external sphincter have a somatic sensory and motor innervation from S4 and S5 roots via the sacral plexus (Fig. 2.32). The rectum and anal canal otherwise have only an autonomic supply (sensory and motor) from the preaortic, superior hypogastric, and pelvic plexuses (see pages 53, 55).

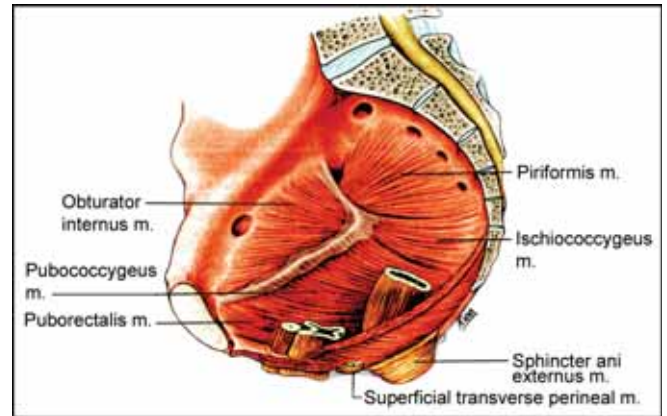


Fig. 2.26: The levator ani and the urogenital diaphragm on the right side of the pelvis viewed from the left

## PELVIC PERITONEUM AND LIGAMENTS

### Peritoneal Pouches

The peritoneum of the anterior abdominal wall is reflected onto the fundus of the bladder to which it is adherent. As it approaches the uterovesical pouch the attachment is loose and this allows accommodation for filling of the bladder. From the uterovesical pouch the peritoneum is reflected onto the uterus at the level of the isthmus. It covers the fundus and back of the uterus, the posterior aspect of the supravaginal cervix and the posterior vaginal fornix. Thence it passes backwards to cover the upper rectum and the posterior wall of the pelvis (Fig. 2.12).

The small peritoneal pouch lying between the rectum and the posterior vaginal fornix and bounded laterally by the uterosacral ligaments is the *rectovaginal pouch*, or *pouch of Douglas*, or *cul-de-sac*. In practice, however, the *whole uterorectal pouch* (the space between the uterus and the broad ligaments in front and the rectum and pelvic wall behind), is often referred to as the pouch of Douglas. This pouch is protected from the exterior only by the vaginal wall and a layer of extraperitoneal fat and connective tissue. This arrangement offers opportunities for injury and infection of the peritoneal cavity by instruments such as douche nozzles inserted into the vagina; as well as easy access for diagnosis, for drainage of a pelvic abscess or haematoma, and for other operations.

## Broad Ligament

Each broad ligament consists of a raised fold of peritoneum and subperitoneal fibromuscular tissue stretching across from the uterus to the side wall of the true pelvis. The fallopian tube is enclosed in its free upper edge and the mesentery of the ovary (*mesovarium*) is attached to its posterior leaf. The portion of the broad ligament which lies between the outer end (*infundibulum*) of the fallopian tube and the pelvic wall is the *infundibulopelvic ligament*; the part between the fallopian tube and level of the attachment of the ovary is the *mesosalpinx*.

The lower part of the broad ligament is wider from front to back than is the upper, the anterior leaf turning forwards into the uterovesical pouch while the posterior leaf continues downwards to a lower level before turning to form the uterorectal pouch. It contains loose cellular tissue and fat, endopelvic fascia condensed to form the cardinal ligaments, the terminal part of the ureter and the paracervical nerve and lymphatic plexuses (Fig. 2.17).

The upper part of the broad ligament contains the fallopian tube and below this the ovarian vessels and nerves which enter the infundibulopelvic ligament to reach the mesovarium. Also lying in the mesosalpinx are the vestigial *Gärtner's duct*, *paroophoron*, *epoophoron* (*organ of Rosenmüller*), *Kobelt's tubules* and the *hydatid of Morgagni* (Figs 2.13 and 2.20). *Gärtner's duct* runs inwards below the fallopian tube until it approaches the uterus when it turns downwards to lie anterolateral to the uterus, cervix and vagina, ultimately disappearing near the lower end of the vagina or in the region of the external urethral meatus.

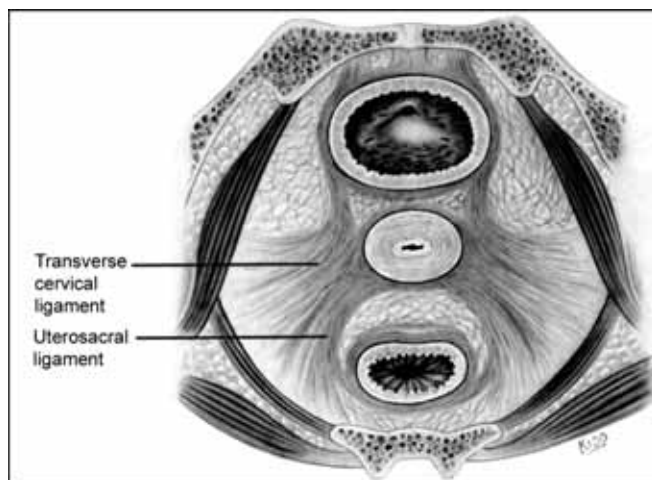


Fig. 2.27: The main supporting ligaments of the uterus viewed from above

Three other paired ligaments closely associated with the broad ligament are described separately.

## Round Ligament

The round ligament is a fibromuscular cord of varying strength and thickness which raises a peritoneal fold on the front of each broad ligament. It extends from the cornu of the uterus to the internal abdominal ring through which it enters the inguinal canal to be inserted in the subcutaneous tissue of the foreparts of the labium majus.

The round ligament is weakly contractile at all times in the mature woman, but especially in late pregnancy and the puerperium.

## Ovarian Ligament

The ovarian ligament is a cord-like fibromuscular structure which links the inner pole of the ovary to the cornu of the uterus (Fig. 2.13). It lies on the posterior leaf of the broad ligament but is embryologically continuous with the round ligament. These two ligaments are the homologues of the gubernaculum testis.

## Uterosacral Ligament

The uterosacral ligament is the inner free edge of the cardinal ligament, or at least is continuous with it. Each uterosacral ligament represents a condensation of endopelvic fascia to form a band which passes backwards beside the rectum from the supravaginal cervix to the sacrum (Fig. 2.27). It contains cellular tissue and is also rich in nerves which use it as a route from the pelvic plexus to the pelvic viscera.

## PELVIC MUSCULATURE

The *pelvic floor* consists of all tissues lying between the pelvic cavity and the surface of the vulva and perineum. It includes the pelvic peritoneum, extra-peritoneal fat and cellular tissue, the levatores ani and their fascial coats, the urogenital diaphragm (triangular ligament), the muscles of the perineum and their aponeuroses, subcutaneous fascia and fat, and finally the skin. The most important of these structures are the levatores ani muscles, which together with the fascia covering their upper and lower surfaces, are collectively called *the pelvic diaphragm*. Sometimes the term pelvic floor is inaccurately used to mean only the perineum and the muscle underlying it: hence the 'pelvic floor repair' operation.

## Levator Ani

The levator ani is a broad sheet of muscle which stretches from the back of the body of the pubis to the sacrum and coccyx and to the anococcygeal raphe, one on each side (Figs 2.25 and 2.26). It is attached laterally to the fascia over the obturator internus (at the 'white line') and to the ischial spine. It sweeps downwards and inwards to meet its fellow from the opposite side and to form a diaphragm which is not complete in that the urethra, vagina and rectum pass through it. Some of its inner fibres are inserted into the vagina and rectum, but not into the bladder and urethra as is sometimes stated. The fascia covering it fuses with vaginal and rectal fascia. Although the muscle functions as a whole, it is divided into several parts, as follows:

### Pubococcygeus

This is the inner and main part of the muscle sheet and is slung from the pubis to the coccyx. Some fibres are inserted into the vaginal and rectal walls and these are sometimes separately defined as pubovaginalis and puborectalis muscles. It is also inserted into the perineal body which it supports.

### Iliococcygeus

This extends from the 'white line' to the sacrum, coccyx, anococcygeal raphe and perineal body.

### Ischiococcygeus (Coccygeus)

This is the portion arising from the ischial spine and inserted into the sacrum and coccyx. Together with the iliococcygeus it forms a sloping roof to the ischioanal fossa (Fig. 2.10).

## The Pelvic Part of Piriformis Muscle

This is sometimes regarded as part of the levator ani; at least it functions with it.

The levator ani is a voluntary muscle supplied by branches of the pudendal nerve, and possibly by fibres coming directly from S3 and S4 roots. It is relaxed during evacuation of the bladder and bowel, that is during a bearing-down effort, but is contracted when the pelvic floor is lifted at the conclusion of such efforts. It is also contracted as part of a protective mechanism during coughing or other sudden strains which increase intra-abdominal pressure.

## The Perineal Muscles and Triangular Ligament

At a lower level in the pelvis is the *urogenital diaphragm (triangular ligament)* with its two layers stretching between and attached to the inferior pubic rami (Fig. 2.3). It is pierced by the dorsal vein of the clitoris which joins the retropubic urethrovesical plexus, by the urethra and by the vagina. Between its fascial layers lie the compressor urethrae and the deep transverse perineal muscles; also branches of the internal pudendal vessels and the pudendal nerve. The deep transverse perineal muscle arises from the ramus of the ischium and is inserted partly into the side walls of the vagina and partly into the perineal body. On the undersurface of the urogenital diaphragm are the vestibular bulb and Bartholin's gland, and immediately superficial to these are the *sphincter vaginae (bulbospongiosus)*, *ischiocavernosus* and *superficial transverse perineal muscles*. Then comes the superficial fascia and skin.

*The perineal body (central tendon of the perineum)* includes the insertions of the anterior fibres of the levatores ani, transverse perineal (superficial and deep), sphincter vaginae, and external sphincter ani muscles.

## PELVIC FASCIA AND CELLULAR TISSUE

All the spaces between organs and between muscles in the pelvis are filled with areolar tissue and with fat which is continuous with the extraperitoneal fat on the abdominal wall. These tissues are especially noticeable in the bases of the broad ligaments (*parametrium*), beneath the uterovesical pouch, in the uterosacral ligaments and around the upper vagina (*paracolpos*).

In certain places, and especially around blood vessels and nerves, connective tissue is condensed to form 'fascial' ligaments which contain some involuntary muscle and elastic tissue and which have an important supporting role. The most clearly defined of these condensations are as follows:

### Transverse Cervical (Cardinal or Mackenrodt's) Ligaments

These fan out from the supravaginal cervix, and upper vagina to the side walls of the pelvis (Figs 2.10 and 2.27).

### Uterosacral Ligament

These can be regarded as the inner edges of the backward-sweeping parts of the cardinal ligaments (Fig.

2.27). They consist of two firm fibromuscular bands passing from the cervix and upper end of the vagina to the lower end of the sacrum. They form two ridges, one on either side of the pouch of Douglas.

### Pubocervical Fascia

This extends from the supravaginal cervix (where it fuses with the cardinal ligaments) down the anterior vaginal wall beneath the base of the bladder. It splits round the urethra and turns forward to be inserted into the body of the pubis and into the upper layer of the triangular ligament.

All the pelvic muscles have aponeuroses on both aspects and these too are designated fascia, as are the connective tissue sheaths of the vagina, bladder and rectum. These and the fascial ligaments mentioned above are directly continuous wherever they come in contact (Figs 2.10 and 2.27).

The specially named fascial layers and ligaments described above are best regarded as part of a continuous connective tissue framework, collectively known as *endopelvic fascia*, which extends throughout the pelvis. Their demonstration at operations is often the result of artificial dissection; indeed, it has been suggested that the pubocervical fascia cannot be identified unless it is hypertrophied as a result of the stress imposed by prolapse of the anterior vaginal wall.

## THE SUPPORTS OF THE GENITAL ORGANS

### Uterus

The uterus is held in a position of anteflexion and anteversion by its weight, by the round ligaments which hold the fundus forwards, and by the uterosacral ligaments which keep the supravaginal cervix far back in the pelvis. To appreciate these actions it is necessary to envisage the uterus rotating around an axis situated at the level of the internal os. The broad ligaments and their cellular tissue also have a steadying effect on the uterus.

The round and broad ligaments do not, however, have any significant action in preventing descent of the uterus. This function is performed almost entirely by the transverse cervical ligaments and their posterior extensions - the uterosacral ligaments. Individual strands of these ligaments are likened to the spokes of a bicycle wheel. Each is weak, but together they form a strong

mechanism. These are inserted not only in the supravaginal cervix but also into the upper vagina, and their support of the vaginal vault is also important in preventing uterine prolapse.

### Vagina

The vagina is supported in its upper part by the lower components of the transverse cervical ligaments which fuse with its fascial sheath. Below this it is held by the fibres of the levatores ani which are inserted into its side walls, by the urogenital diaphragm, and by the perineal muscles. The anterior vaginal wall, urethra and bladder base are supported by the pubocervical fascia and also, it is said, by the posterior vaginal wall and perineal body on which they rest when the woman is standing. The posterior vaginal wall rests on the rectovaginal fascia and perineal body. The perineal body supports the vaginal walls where the pelvic diaphragm offers an elastic foundation to which the important inelastic ligaments are attached.

However, by themselves the perineum and the levator muscles are insignificant as supporting structures. This fact can be demonstrated at operation. If they are divided there is no effect on the downward mobility of the uterus. Moreover, complete disruption of the perineum in childbirth, with consequent divarication of the levatores ani, usually does not result in the later development of either uterine or vaginal prolapse, nor even rectocele. This clinical observation was made many centuries ago. Occasionally, disruption of the perineal body leads to a situation where contraction of the levatores ani widens the hiatus rather than tightening it. Such patients may even develop cystocele and, in extreme cases, may have prolapse of the uterus and rectum as well.

The idea that the vagina is supported by the perineum and the uterus by the vagina still lingers in the minds of gynaecologists and explains why so many take the view that no operation for any type of genital prolapse is complete unless perineorrhaphy be included, and that vaginal hysterectomy must always be followed by tightening of the posterior vaginal wall and perineum to avoid subsequent vault prolapse. In fact the avoidance of posterior colpo-perineorrhaphy in those who have no evidence of vaginal or perineal body descent generally has no untoward effects and has many advantages.



## BLOOD VESSELS OF THE PELVIS

The pelvic vasculature is a high-volume, high-flow system with enormous expansive capabilities throughout reproductive life. Blood flow through the uterine arteries increases to about 500 mL/min in late pregnancy. In nonpregnant women, certain conditions, such as uterine fibroids or malignant neoplasms, may be associated with neovascularisation and hypertrophy of existing vessels and a corresponding increase in pelvic blood flow. It is necessary to understand the system of blood flow since a knowledge of the volume and flow characteristics of the pelvic vasculature in different clinical situations will enable the surgeon to anticipate problems and take appropriate preoperative and intraoperative measures (including blood and blood product availability) to prevent or manage haemorrhage. The collaterals in the pelvis are extensive.

The pelvic vasculature is supplied with an extensive network of collateral connections that provides a rich anastomotic communication between different major vessel systems. This degree of redundancy is important to ensure adequate supply of oxygen and nutrients in the event of major trauma or other vascular compromise. Hypogastric artery ligation continues to be used as a strategy for management of massive pelvic haemorrhage when other measures have failed. Bilateral hypogastric artery ligation, particularly when combined with ovarian artery ligation, dramatically reduces pulse pressure in the pelvis, converting flow characteristics from that of an arterial system to a venous system and allowing use of collateral channels of circulation to continue blood supply to pelvic structures. The significance of collateral blood flow is demonstrated by reports of successful pregnancies occurring after bilateral ligation of both hypogastric and ovarian arteries.

### Arteries

#### *Ovarian Artery*

The ovarian artery branches from the aorta at approximately the same level as the renal artery. It runs downwards and laterally retroperitoneally, and crosses the ureter to reach the brim of the pelvis where it enters the infundibulopelvic ligament (Fig. 2.28). Here it divides to send main branches to the ovary through the mesovarium. These, together with their tributaries within the ovary, are coiled (Figs 2.29 and 2.30).

One branch, if not the continuation of the parent trunk, runs towards the cornu of the uterus lying parallel to and just below the fallopian tube, and makes an end-to-end anastomosis with the terminal part of the uterine artery. There is thus a continuous arterial arch and it is impossible to define the limits of the ovarian and uterine contributions. From the arch in the mesosalpinx, vessels run off to supply the round ligament and tube.

The anastomosis is so free that fluid injected into the uterine artery alone passes easily into the vessels within the substance of the ovary (Fig. 2.29). On embryological grounds it is reasonable to suppose that the tube is supplied by the uterine artery. In fact, it can be equally well maintained by the ovarian vessels.

#### *Common Iliac Artery*

The two common iliac arteries (Fig. 2.28) result from the bifurcation of the aorta on the left side of the body of the fifth lumbar vertebra. Each runs downwards and outwards for a distance of 4 or 5 cm (depending on the side) before dividing into the external and internal iliac arteries. At the point of division the ureter lies in front and the sacroiliac joint behind.

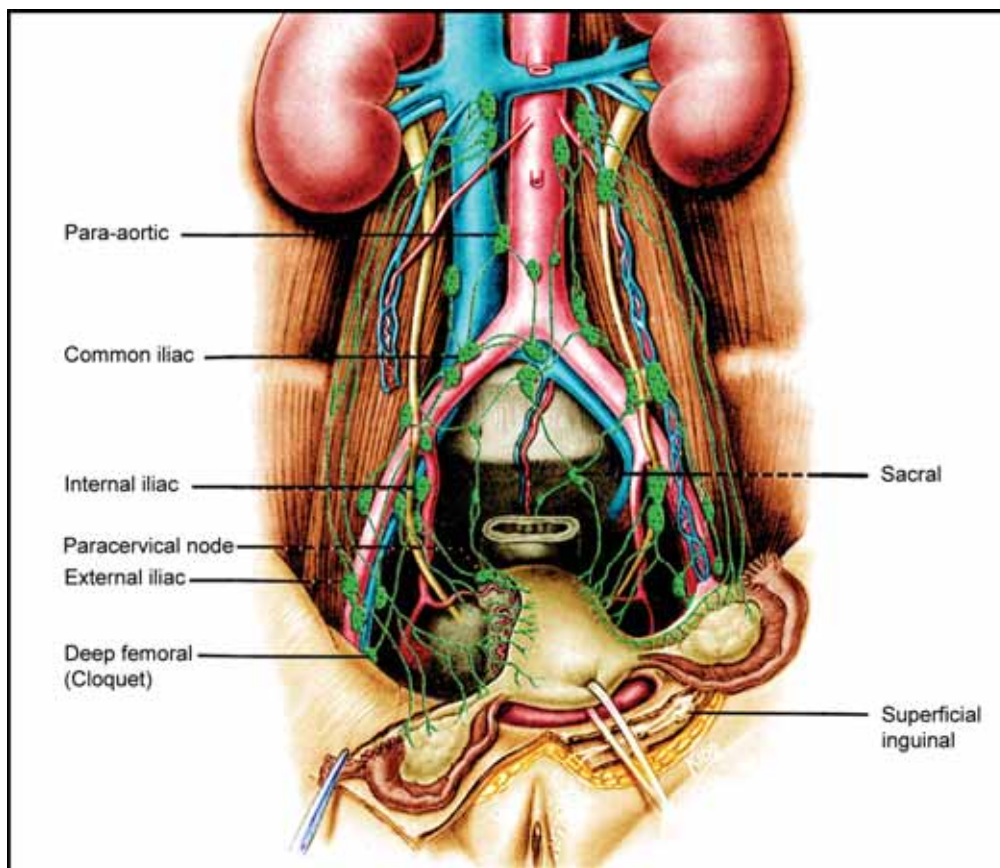
Behind the right common iliac artery are the terminations of the two common iliac veins and the lowermost part of the inferior vena cava. The right common iliac vein lies to its outer side at a lower level.

The artery on the left side has the superior rectal (haemorrhoidal) artery as an anterior relation; the left common iliac vein is partly behind and partly medial to it.

#### *External Iliac Artery*

The external iliac artery (Fig. 2.28) runs downwards and outwards from the common iliac artery towards the thigh and, on passing under the inguinal ligament, becomes the femoral artery. It lies at the brim of the pelvis, on the medial border of the psoas muscle, and immediately beneath the peritoneum. Numerous lymphatic vessels and nodes are associated with it. Its main branches are the inferior (deep) epigastric and deep circumflex iliac arteries.

The anterior relations are the ovarian vessels and the round ligament. The external iliac vein lies behind the artery in its upper part but becomes medial at a lower level. As the external iliac artery becomes the femoral artery, the femoral nerve lies on its outer, and the femoral vein on its inner side.



**Fig. 2.28:** The lymphatic drainage of the internal pelvic organs together with the main arteries and veins. The paracervical node is rarely present; usually there is merely a plexus of lymph vessels at this site. The lettering applies to lymph nodes, not blood vessels

### Internal Iliac Artery

The internal iliac artery (Fig. 2.28) arises from the bifurcation of the common iliac artery and, in the foetus, is the umbilical (hypogastric) artery. After birth all except some of the pelvic portion becomes obliterated.

From its origin the internal iliac artery descends into the pelvis as far as the greater sciatic foramen where it divides into anterior and posterior trunks. The ureter runs down its front aspect and behind it are the internal iliac vein(s), the lumbosacral nerve trunk and the pyriformis muscle. On its outer side is the external iliac vein and, lower down, the obturator nerve.

The posterior division passes through the foramen to supply the muscles of the buttock. The anterior division supplies the internal pelvic organs and terminates as the internal pudendal artery (*see below*).

The branches of the *anterior* division of the internal iliac artery are the following arteries: superior vesical;

inferior vesical; middle rectal; uterine; vaginal; obturator; internal pudendal; and inferior gluteal (sciatic). The last two are its terminal branches.

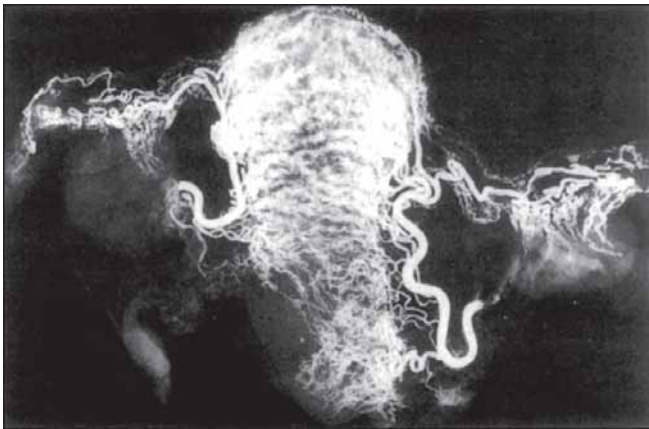
The branches of the *posterior* division are the iliolumbar artery; the lateral sacral arteries; and the superior gluteal artery.

Ligation of the internal iliac artery is often resorted to in the management of postpartum haemorrhage. Physiologically active anastomoses develop soon after between the systemic and pelvic arteries, leading to the formation of a collateral circulation. The ilio-lumbar, lateral sacral and middle rectal arteries anastomose with the lumbar, middle sacral and superior rectal arteries, respectively (the lumbar and middle sacral arteries arise from the aorta and the superior rectal artery arises from the inferior mesenteric artery). The correct point for internal iliac ligation is, therefore, not immediately after the bifurcation of the common iliac, but immediately

below the last branch of the posterior division. This point also preserves and bypasses the anastomosis of the superior gluteal artery and profunda femoris which may be vital to the survival of the leg where the external iliac artery has been damaged by disease or become spastic consequent to operative manipulation.

### Uterine Artery

The uterine artery arises from the anterior division of the internal iliac artery, either directly or as a branch of the superior vesical artery, the distal part of which is obliterated in the adult. It runs forwards and inwards in the base of the broad ligament, crossing *above* and almost at right angles to the ureter, and approaches the uterus at the level of the internal os (Fig. 2.17). Here it gives off a descending branch to supply the lower cervix, and a circular branch (*the circular artery of the cervix*) from which arise the anterior and posterior *azygos arteries to the vagina*. There are also subsidiary branches to the lower end of the ureter, to the bladder and to the vagina. The main trunk is coiled and tortuous and turns upwards beside the uterus. It supplies the uterus at all levels, and ends by anastomosing with the ovarian artery to form a continuous arterial arch (Fig. 2.29).



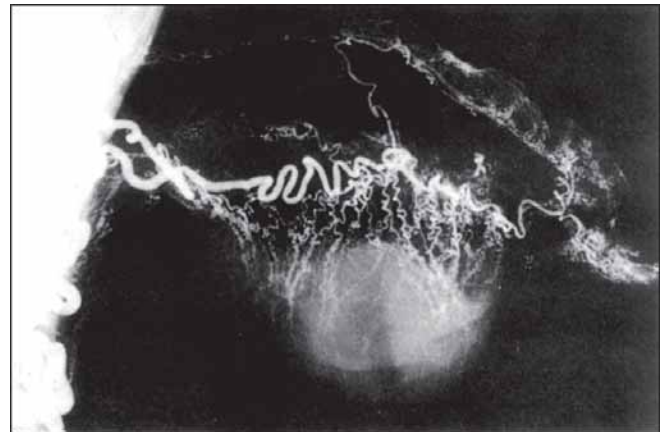
**Fig. 2.29:** A radiograph of the uterus and ovaries, showing the uterine arteries injected with radio-opaque material. The right uterine artery was damaged and displaced during hysterectomy but the descending cervical branch is well seen on the left side. Note the characteristic spiral shape of the coronary arteries in the myometrium and of the arterioles in the ovary. The ovarian arteries were *not* injected and the radiograph indicates the free anastomosis between the uterine and ovarian vessels. This component of the blood supply can be diminished after panhysterectomy and explains the early cessation of menstrual function in some of these women

The main branches to the uterus each divide into *anterior and posterior arcuate arteries* which are disposed circumferentially in the myometrium and anastomose with those from the opposite side (Fig. 2.29). The uterus is therefore least vascular in the middle line which becomes the natural site for an incision.

The arcuate arteries give off serosal branches and *radial arteries* which penetrate the myometrium to end as *basal arteries* which supply the endometrium. Arcuate and radial arteries are also coiled and the purpose of this is to reduce arterial pressure without reducing the flow, an important matter in pregnancy. The coiling of the main uterine artery may have a similar purpose although it is also suggested that this is to allow lengthening and accommodation of the vessel to the enlarging uterus during pregnancy.

### Vaginal Artery

The vaginal artery is usually a separate branch (or branches) of the internal iliac artery but may come off the first part of the uterine artery. It passes forwards and inwards low in the broad ligament to reach the lateral vaginal fornix. In the vaginal wall it anastomoses with the azygos branches of the circular artery of the cervix. The lower vagina is supplied from the middle and inferior rectal vessels and by branches from the internal pudendal artery.



**Fig. 2.30:** The blood supply to the ovary and fallopian tube as revealed by a uterine arteriogram. The ovarian artery was not injected but is shown filled from its connection with the terminal part of the uterine artery. The spiral arterioles entering the ovary through the mesovarium are well shown, and also branches to the fallopian tube with a continuous vessel running just below and parallel to it

### Internal Pudendal Artery

The internal pudendal artery is the terminal branch of the internal iliac artery which passes out of the pelvis through the greater sciatic notch, curls round the ischial spine and returns to the lateral wall of the ischioanal fossa through the lesser sciatic notch. At this point it lies 4 cm above the ischial tuberosity. Together with the pudendal nerve, it runs forward in Alcock's canal under the lee of the inferior pubic ramus and then enters between the layers of the triangular ligament to give branches to the labia, vagina, bulbs of the vestibule, perineum and various muscles. It ends as the dorsal artery of the clitoris (Fig. 2.31).

### Superficial and Deep External Pudendal Arteries

These are branches of the femoral artery which come off just below the inguinal ligament and turn inwards to supply the foreparts of the vulva.

#### Veins

The veins of the pelvis normally accompany the arteries and have the same names. Sometimes there are two veins to one artery, not an uncommon finding in the case of

the uterine and internal iliac vessels. In the broad ligament near the mesovarium there is a *pampiniform plexus* of veins which drains into the ovarian and uterine trunks. It is this plexus which sometimes becomes varicose and gives rise to a *pelvic* or *broad ligament varicocele*. The right ovarian vein joins the inferior vena cava, but the left usually drains into the left renal vein.

There are plexuses of veins around the vagina, the urethrovesical junction and the anorectal junction, and all ultimately drain into the internal iliac veins. The venous return from the rectum and pelvic colon enters the portal system by way of the inferior mesenteric vein.

The uterine veins also communicate with the vaginal plexuses and this accounts for vaginal metastases in cancer of the body of the uterus. The vessels of the bulb and clitoris link with the vesical and vaginal plexuses.

The pelvic plexuses and veins also have communications with the presacral and lumbar channels of the *vertebral plexus* and in this way it is possible for blood, tissue cells, emboli and organisms to travel to remote parts of the body without passing through the heart and lungs (Fig. 2.32). This is probably the explanation for the occurrence of metastatic growths in the spine and brain when the primary is in the uterus.

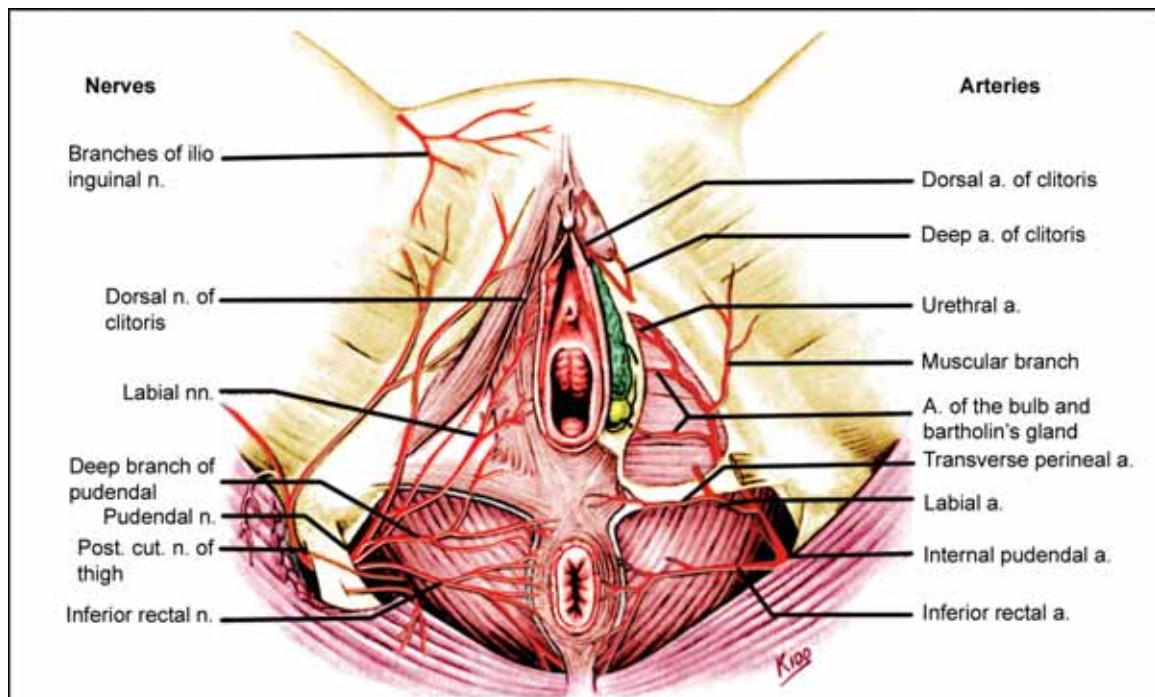
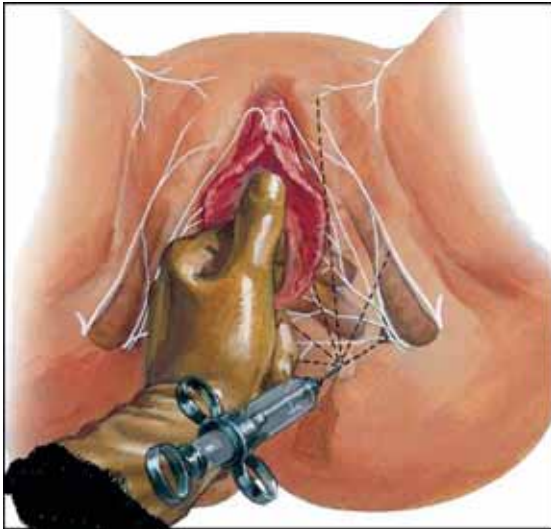


Fig. 2.31: The blood vessels and nerves of the vulva and perineum



**Fig. 2.32:** The surface anatomy of pudendal block and local vulvar anaesthesia. Some surgeons prefer to inject the pudendal nerves by a direct approach through the side walls of the vagina; a specially devised and guarded needle is available for this technique. (By permission of the Editor, *BMJ*)

This collateral pathway is especially important in late pregnancy when the large uterus always obstructs the inferior vena cava of the woman lying on her back. It is mainly when this alternative venous return route is inadequate that she suffers the supine hypotension, or vena caval, syndrome.

## LYMPHATIC DRAINAGE

The pelvic lymph nodes are generally arranged in groups or chains and follow the course of the larger pelvic vessels, for which they are usually named. Smaller nodes that lie close to the visceral structures are usually named for those organs. Lymph nodes in the pelvis receive afferent lymphatic vessels from pelvic and perineal visceral and parietal structures and send efferent lymphatics to more proximal nodal groups. The number of lymph nodes and their exact location is variable; however, certain nodes tend to be relatively constant:

- Obturator node in the obturator foramen, close to the obturator vessels and nerve.
- Nodes at the junction of the internal and external iliac veins.
- Ureteral node in the broad ligament near the cervix, where the uterine artery crosses over the ureter.

- The Cloquet or Rosenmüller node—the highest of the deep inguinal nodes that lies within the opening of the femoral canal.

## Vulva and Perineum

The lymphatics of the vulva pass forwards to the mons veneris and the subcutaneous tissues of the lower abdominal wall to enter the medial group of the superficial inguinal nodes. These connect with the deep inguinal (femoral) groups from which lymphatics pass to the external, and ultimately to the common iliac lymph nodes (Fig. 2.28). The deep femoral node of Cloquet, which lies beneath the inner end of the inguinal ligament, is said to drain the clitoris directly, thus accounting for carcinoma of the clitoris supposedly having a poor prognosis; but this is probably not true.

Lymphatics from the deep tissues of the vulva accompany the internal pudendal vessels to the internal iliac nodes.

## Vagina

The lower vagina drains to the inguinal and femoral nodes in the same way as the vulva. The drainage of the middle and upper vagina is the same as that of the cervix.

## Cervix

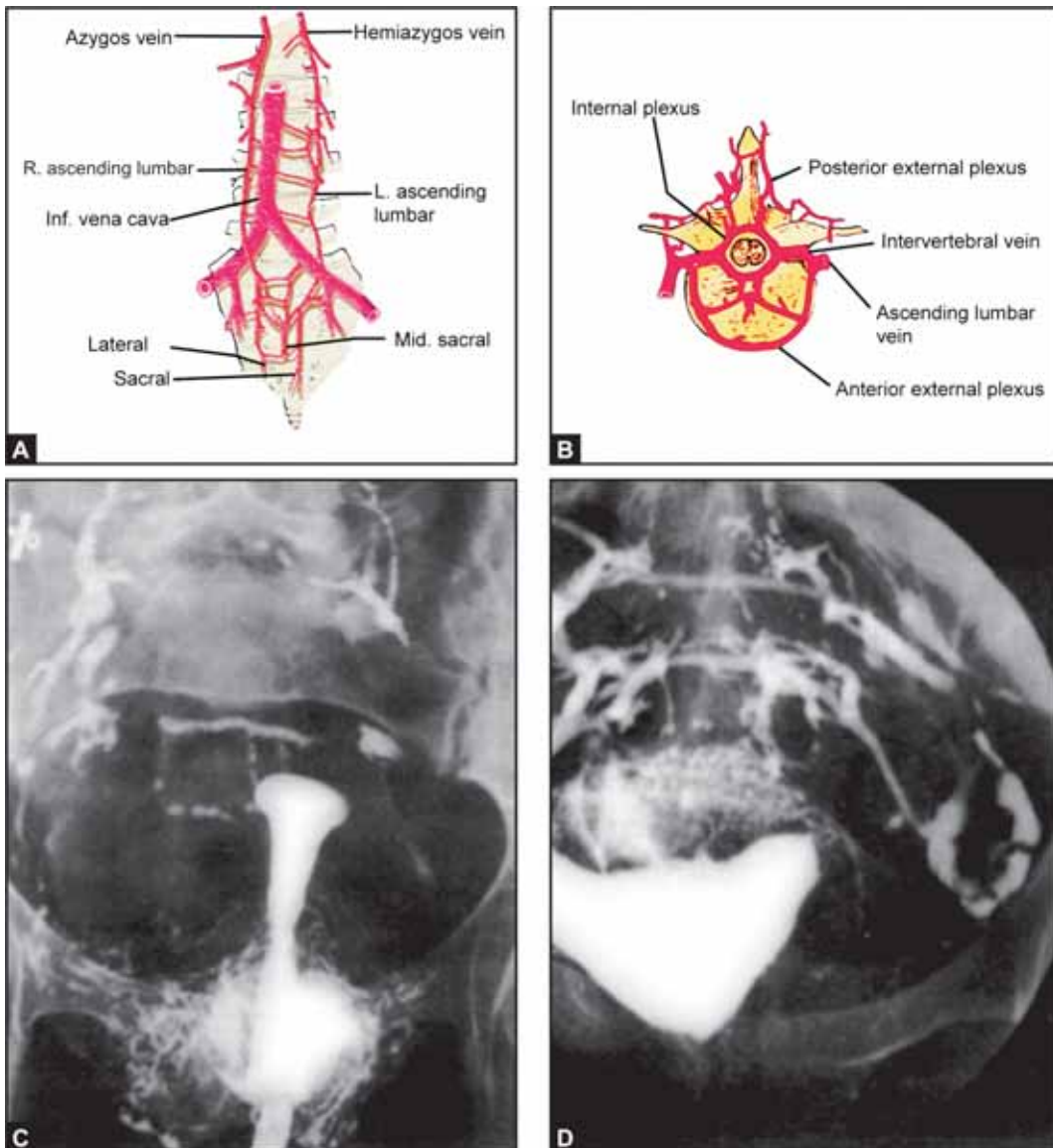
Lymphatics from the cervix run in the uterosacral ligaments and in the cellular tissue beneath these to the obturator, external and internal iliac, and sacral nodes. There is a plexus of lymphatic vessels, and rarely one node, in the broad ligament beside the cervix. The internal and external iliac nodes communicate with those around the common iliac vessels and ultimately with the para-aortic groups (Fig. 2.28).

## Corpus Uteri

The lower part of the body of the uterus has the same lymphatic connections as the cervix. The fundus has an additional drainage by lymphatics which accompany the ovarian vessels, and by others which accompany the round ligament to the abdominal wall and thence to the superficial inguinal nodes.

## Fallopian Tube and Ovary

The tube drains in part with the fundus of the uterus but mainly with the ovary. Lymphatics from the ovary



**Figs 2.33A to D:** The vertebral venous plexus responsible for some return of blood from the pelvic organs, (A) and (B) Diagrammatic representations of the anatomy, (C) Intravasation at the level of the cervix during hysterocelebration, with entry of the medium into the presacral venous plexus, the ascending lumbar and the intervertebral veins. Radiograph obtained in an apparently normal woman lying quietly, (D) Intravasation of the fundus with entry of the medium into veins which communicate with the presacral plexus, (A, B and C by permission of the Editor, *J Obstet Gynaecol Br Emp*)

accompany the ovarian vessels to reach the aortic nodes (Fig. 2.28). They are said to communicate with those from the opposite gonad by crossing the fundus uteri; this is doubtful but is put forward as one explanation of the tendency for ovarian cancer to be bilateral.

### Urethra and Bladder

The external urethral meatus drains with the vulva to the inguinal nodes. The remainder of the urethra, together with the bladder, has lymph vessels which go to the external, internal and common iliac nodes.

## Sigmoid Colon

From this organ, lymphatics accompany the inferior mesenteric vessels to the preaortic nodes.

## Anus and Rectum

The anal orifice drains to the superficial inguinal nodes; the anal canal to the internal iliac (along with the internal pudendal vessels). The lower rectum also drains to the internal inguinal nodes, the lymph channels accompanying the inferior rectal and internal pudendal vessels. That of the upper rectum is to the preaortic nodes, the lymph channels being associated with the superior rectal vessels.

## INNERVATION OF PELVIC ORGANS

### Somatic Nerves

The skin of the mons veneris and the foreparts of the vulva are supplied by the *ilioinguinal* nerve and the genital branch of the *genitofemoral* nerve, both arising from the L1 and L2 roots of the lumbar plexus.

The outer parts of the labia posteriorly and the perineum receive some sensory fibres from the perineal branch of the posterior cutaneous nerve of the thigh (Fig. 2.31).

The main somatic supply to the pelvic organs is, however, the *pudendal nerve* which is both motor and sensory and is formed from the S2, S3 and S4 roots of the sacral plexus. This leaves the pelvis through the greater sciatic notch, curls round the ischial spine and, in company with the internal pudendal vessels, re-enters through the lesser sciatic notch to lie on the outer wall of the ischiorectal fossa in Alcock's canal. Its branches run forwards and inwards between the two layers of the triangular ligament.

The pudendal nerve supplies sensory fibres to the skin of the vulva, external urethral meatus, clitoris, perineum and the *lower* vagina. It provides motor fibres to all the voluntary muscles, including the compressor urethrae, sphincter vaginae, levator ani and external anal sphincter.

Pudendal block (Fig. 2.32) is carried out by injecting a local anaesthetic solution around the nerve as it circles the ischial spine and comes to lie on the medial aspect of the inferior pubic ramus. In order to obtain complete anaesthesia of the vulva, the other cutaneous nerves require to be injected. Relaxation of the levator ani needs

direct injection of the muscle and its fascial coats, probably because the muscle is partly innervated from above by fibres arising directly from the S3 and S4 roots.

Pudendal block anaesthesia carries a slight but definite risk of injury to the internal pudendal vessels with consequent haematoma formation. In obstetric practice it is rarely necessary since local infiltration of the perineum, the adjacent vaginal wall and the levatores ani muscles suffices for all except the more difficult operations.

The skin of the vulva is very sensitive and perineal injuries are especially painful. The discomfort which results from perineorrhaphy or episiotomy, however, is mostly due to spasm in the underlying muscles.

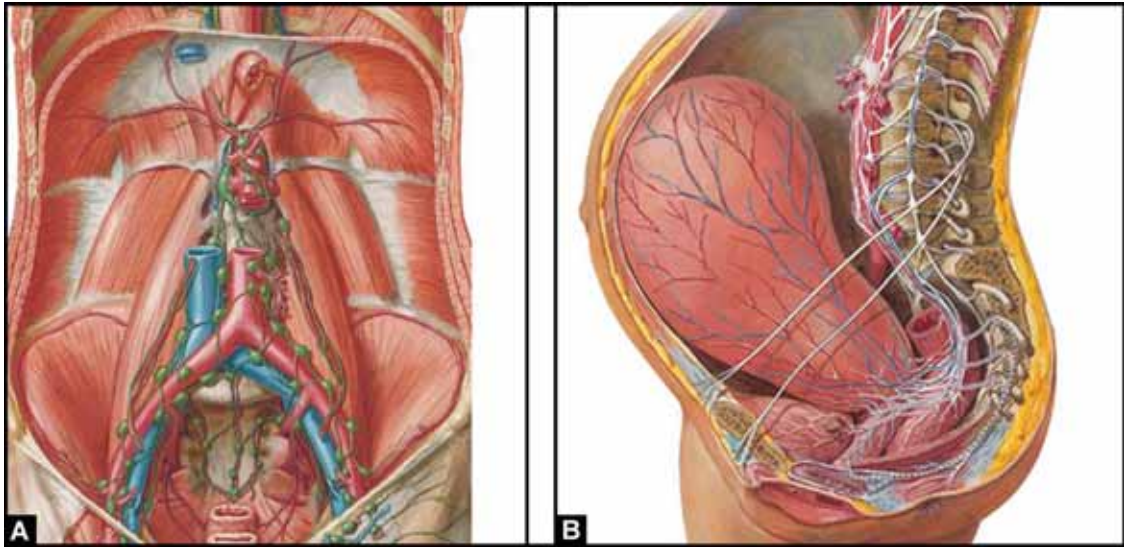
*Except in its lower part*, the vagina is remarkably insensitive to ordinary stimuli. Diseases such as vaginitis, ulcers, cancer and injuries, including burns, do not cause pain. Vaginal surgery can be carried out with minimal infiltration of local anaesthetic, provided the perineum and introitus are avoided. This insensitivity is explained by the fact that most of the vagina is supplied by autonomic and not somatic nerves (Fig. 2.34B).

### Autonomic Nerves

All the internal organs of reproduction, including the upper vagina, together with the urinary apparatus, rectum and colon, have only an autonomic innervation. The blood vessels are controlled by their own intrinsic nerves; what follows concerns other tissues. The autonomic nerves to these carry both sensory and motor fibres, adrenergic and cholinergic.

### Sympathetic

Sympathetic nerves, arising from segments T5 and T6 in the case of motor nerves, and from segments T10 to L1 in the case of sensory nerves, pass down from the coeliac plexus through the intermesenteric plexus, lying retroperitoneally on the front of the abdominal aorta. Over the bifurcation of the aorta and the promontory of the sacrum is a complicated network lying just beneath the peritoneum; this is called the superior hypogastric plexus or presacral nerve (Fig. 2.34B). From this, two main chains (*hypogastric nerves*) run outwards and downwards, one on each side wall of the pelvis. These join the *pelvic (inferior hypogastric) plexuses* which lie on either side of the ampulla of the rectum extending forwards beneath the uterosacral and broad ligaments.



**Figs 2.34A and B:** The autonomic innervation of the internal genitalia. (A) Nerves to the tubes and ovaries travel with the ovarian vessels directly from the preaortic plexuses. (B) The uterus and upper vagina is supplied from the hypogastric plexus which is composed of fibres from the superior hypogastric plexus (presacral nerves) together with a contribution from S2, S3 and S4 nerve roots

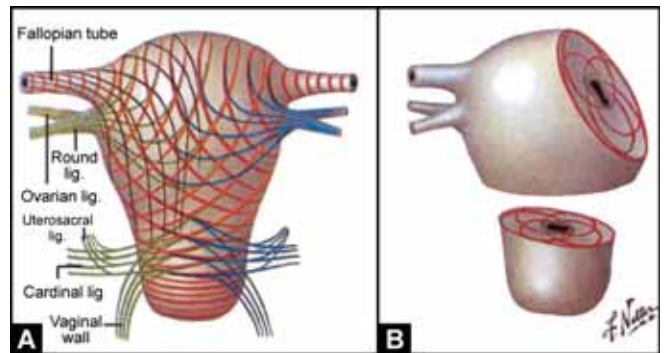
The forward extension of the pelvic plexus is often called the Lee-Frankenhäuser plexus.

### Parasympathetic

The pelvic plexus also receives important motor and sensory fibres from S2, S3 and S4 nerve roots. Amongst other functions they probably carry sensation from the cervix and lower uterus and thus mediate the low backache which is sometimes a feature of lesions in these organs.

With the exception of the fallopian tube and ovary, the pelvic plexuses supply sympathetic and parasympathetic nerves to all the pelvic organs, including the bladder and bowel. Those to the cervix and uterus pass through the paracervical ganglia in the bases of the broad ligaments. The fundus of the uterus probably receives additional twigs from nerves which accompany the ovarian vessels (Fig. 2.34C).

Sympathetic nerves of the uterus are sensory and possibly motor but their functions are not well understood; and there is doubt whether the uterus, except in its lower part, receives parasympathetic nerves. A motor function for such nerves, and an inhibitory action by sympathetic nerves, although often postulated, has not been demonstrated in the human being. Stimulation of the autonomic system produces uterine responses which vary from animal to animal.



**Fig. 2.34C:** (A) Scheme of uterine musculature (B) Diagram to show how spiral fibers into wall and interface

In women, division of all uterine nerves, or of the spinal cord at very high levels, does not appear to affect myometrial contractility, not even in labour. Moreover, presacral neurectomy alone does not abolish the pain of labour, even though it may sometimes improve dysmenorrhoea. To remove all sensation from the uterus and other pelvic organs it is necessary to divide every nervous connection (including the parasympathetic) or to block the spinal pathway above the level of T10.

The cervix and body of the uterus are relatively insensitive to touching, cutting and burning and can be operated on without any form of anaesthesia. Abdominal hysterotomy, for example, can be performed under local



infiltration anaesthesia of the abdominal wall alone; cauterization of the external aspect of the cervix of the conscious woman causes little discomfort. The application of a volsellum to the cervix sometimes causes a momentary stab of pain; touching the internal os with a sound and scratching the endometrium with a curette also cause fleeting discomfort. When the cervix is unusually sensitive it often betokens chronic cervicitis with associated parametritis.

Despite what is said above, touching the cervix or the introduction of an instrument into its canal, especially in a woman under emotional tension, can cause severe vasovagal collapse. Sudden death from this cause is a remote but real possibility.

Distension of the uterus or dilatation of the cervical canal causes intense colicky pain or a sickening deep-seated ache in the hypogastrium, iliac fossae and the sacral area.

The bladder is also innervated from the pelvic plexus. Motor parasympathetic nerves are responsible for the contraction of the detrusor muscle. It is doubtful whether there is a sympathetic motor supply; if there is, its function is to inhibit the detrusor muscle and contract the sphincter mechanism of the urethrovesical junction. This is the hypothetical basis for the administration of ephedrine in the treatment of enuresis and other conditions in which bladder control is poor. Bladder

sensation is conveyed mainly by sympathetic but also by the parasympathetic nerves (*see* page 39 and Fig. 2.23).

Presacral neurectomy does not usually cause more than temporary disturbance of micturition, but blocking or section of the nerve trunks leading from the pelvic plexus to the floor of the bladder abolishes or diminishes sensation and detrusor activity.

The urethra is under the same nervous control as the bladder, except for the voluntary external sphincter muscle which is motivated by branches of the pudendal nerve.

### Fallopian Tubes and Ovaries

The fallopian tubes and ovaries are supplied by parasympathetic and sympathetic nerves which accompany the ovarian vessels and come directly from the preaortic plexuses (Fig. 2.34A). They are both motor and sensory. The segmental supply is T10 or T11 for the ovary and T11 or T12 for the tube. Pain from the adnexa is usually referred to the lower abdominal wall on one or other side but can be central.

The ovary is insensitive except to squeezing on bimanual examination. *The fallopian tube, however, is unlike other viscera in that it is sensitive to cutting, crushing and touching*, as can be demonstrated during sterilisation operations carried out under local analgesia.

# CHAPTER 3

## Ovarian Functions

The Production of Ova	57
Ovarian Hormones	66
Oestrogens	67
Pituitary Hormones	73
Pituitary-Hypothalamic Relations	74
Pituitary-Ovarian Relations (Control of Ovulation)	76
Hormone Levels and Assays	77

Neuroendocrinology is a dynamic process and it represents facets of two traditional fields of medicine: endocrinology, which is the study of hormones (i.e., substances secreted into the bloodstream that have diverse actions at sites remote from the point of secretion), and neuroscience, which is the study of the action of neurons. It is interesting to know that the discovery of neurons that transmit impulses and secrete their products into the vascular system to function as hormones themselves, a process known as neurosecretion, demonstrates that the two systems are intimately linked. For instance, the menstrual cycle is regulated through the feedback of hormones on the neural tissue of the central nervous system (CNS).

The phases of the ovarian cycle are characterized as follows:

1. Follicular phase—hormonal feedback promotes the orderly development of a single dominant follicle, which should be mature at midcycle and prepared for ovulation. The average length of the human follicular phase ranges from 10 to 14 days, and variability in this length is responsible for most variations in total cycle length.
2. Luteal phase—the time from ovulation to the onset of menses, with an average length of 14 days.

The extremes of reproductive life (after menarche and perimenopause) are characterized by a higher percentage of anovulatory or irregularly timed cycles.

At the beginning of each monthly menstrual cycle, levels of gonadal steroids are low and have been decreasing since the end of the luteal phase of the previous cycle.

With the demise of the corpus luteum, FSH levels begin to rise and a cohort of growing follicles is recruited. These follicles each secrete increasing levels of oestrogen as they grow in the follicular phase. This, in turn, stimulates the uterine endometrial proliferation. With the rising oestrogen levels, the same provide negative feedback on pituitary FSH secretion, which begins to wane by the midpoint of the follicular phase. Conversely, LH initially decreases in response to rising

oestradiol levels, but late in the follicular phase the LH level is increased dramatically (biphasic response). At the end of the follicular phase (just prior to ovulation), FSH-induced LH receptors are present on granulosa cells and, with LH stimulation, modulate the secretion of progesterone. After a sufficient degree of oestrogenic stimulation, the pituitary LH surge is triggered, which is the proximate cause of ovulation that occurs approximately 36 hours later. Ovulation triggers the transition to the luteal-secretory phase. The oestrogen level decreases through the early luteal phase from just before ovulation until the midluteal phase, when it begins to rise again as a result of corpus luteum secretion. Progesterone levels rise precipitously after ovulation and can be used as a presumptive sign that ovulation has occurred. Both oestrogen and progesterone levels remain elevated through the lifespan of the corpus luteum and then wane with its demise, thereby setting the stage for the next cycle.

The regulation of ovarian function occurs through autocrine, paracrine, and endocrine mechanisms. The growth and differentiation of ovarian cells are particularly influenced by the insulin-like growth factors (IGF). The IGF amplify the actions of gonadotropin hormones on autocrine and paracrine growth factors found in the ovary. Insulin-like growth factor 2 is the principal growth factor found in follicular fluid although other factors, including IGF-1, TNF- $\alpha$ , TNF- $\beta$ , and EGF, also play important roles. Disruption of these autocrine and paracrine intraovarian pathways may be the basis of polycystic ovarian disease and disorders of ovulation.

The two ovaries function as one, and between them normally shed only one ovum at a time. Moreover, they do not necessarily take it in turn to ovulate. If one ovary is removed the other maintains a full function, ovulating every month according to Lipshutz's 'Law of Follicular Constancy' which was established at the beginning of the last century. The same is true of a portion of one ovary but if the remaining fragment is very small it may prove inadequate.

The ovaries have two functions: the production of ova; and the production of hormones. The latter is secondary to the former and is present to a limited extent for a few years before regular ovulation is established and for some time after ovulation ceases. Both these functions are controlled through the hypothalamic-pituitary—ovarian axis by endocrine, paracrine and autocrine pathways.

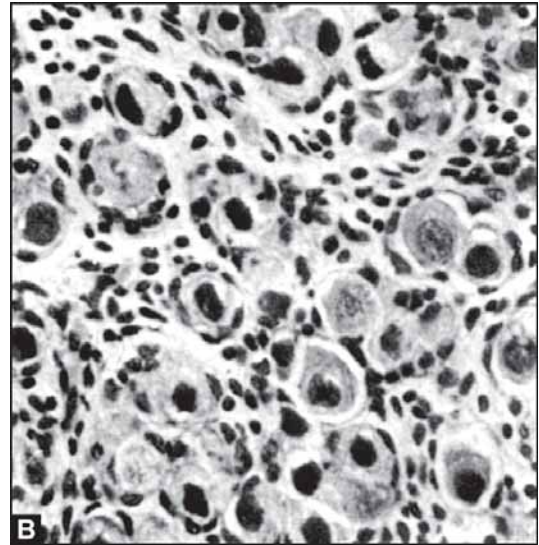
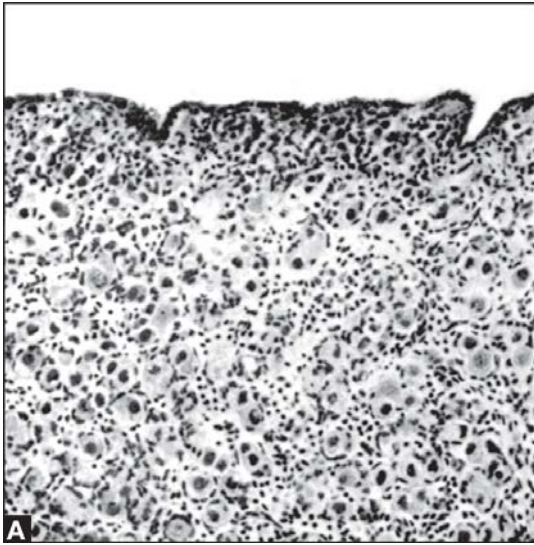
## THE PRODUCTION OF OVA

The primordial germ cells originate in the endoderm of the yolk sac, allantois and hindgut of the embryo and migrate to the genital ridge where the ovary is formed. Oogenesis begins in the ovary at 6-8 weeks gestation. Mitotic division of the germ cells results in the formation of oogonia, which reaches a maximum number of 6-7 million oogonia in a 16-20 week old foetus. By 11-12 weeks the transformation of oogonia to oocytes has begun and there is a steady decline in the numbers. The oocytes enter the first meiotic phase and arrest in prophase.

The ovary of the female child at birth contains all the *primary oocytes* which it will ever possess, and these are scattered amongst the mesenchymal stroma cells of the medulla and cortex (*see* Figs 3.1A and B). The total content of both ovaries at birth is estimated at about 2 million. It is further reduced during childhood so that at puberty the figure is about 300000-500000. Of these, not more than 500 are destined to mature during the individual's lifetime and the remainder will be lost by some form of degenerative process. *Each primordial follicle* consists of an *oocyte* surrounded by a single layer of *granulosa* or *pregranulosa cells* which are specially differentiated stromal cells. A number of follicles (which depends on the residual number of follicles in the ovary but is generally less than 12 in each ovary) may develop several layers of granulosa cells and even show some luteinization and liquor folliculi formation during the weeks preceding birth. These changes probably reflect the action of placental gonadotrophin and they soon disappear in infancy, as do multiovular follicles and multinucleated ova also found in the foetus at term. The occasional persistence of multiovular follicles to adult life may account for certain cases of multiple pregnancy.

During childhood, the ovary grows in size by an increase of stroma but is relatively quiescent. Nevertheless, ova do attempt to ripen from time to time but they fail to complete the process and become blighted.

Ovulation is the process by which an ovum, in the form of a *secondary oocyte* (*see below*), is discharged from the ovary to become a gamete. The ovary probably first sheds an ovum about the time of the onset of menstruation, but ovulation is not usually established as a regular phenomenon until 2-3 years after the menarche. It then continues until the age of 45-50 years, although it may get less frequent and less regular after



**Figs 3.1A and B:** The ovary of the newborn child, (A) Low-power photomicrograph showing the surface epithelium with the cortex packed with primordial ova. (B) High-power view showing some of the oocytes surrounded by a single layer of granulosa (or pre-granulosa) cells to form primordial follicles

the age of 40 years. Ovulation occasionally precedes the establishment of menstruation and sometimes occurs even after the cessation of menstrual periods. This accounts for the rare cases of pregnancy reported to have occurred before the menarche and after the menopause.

The adult ovary goes through a cycle of activity which occupies approximately 28 days. The cycle commences on the first day of menstruation and has two phases: the ripening of an ovum which occupies the first 14 days - *the follicular phase*; and the formation, activity, function and degeneration of the corpus luteum which occupies the second 14 days - *the luteal phase*. These two phases are separated by ovulation. The duration of the luteal phase is more constant than that of the follicular phase and is generally reckoned as  $14 \pm 2$  days. Nevertheless, it is subject to variations.

### Primordial Follicles

The initial recruitment and growth of the primordial follicles is gonadotropin independent and affects a cohort over several months. However, the stimuli responsible for the recruitment of a specific cohort of follicles in each cycle are unknown. At the primordial follicle stage, shortly after initial recruitment, FSH assumes control of follicular differentiation and growth and allows a cohort of follicles to continue differentiation. This process signals the shift from gonadotropin-independent to

gonadotropin-dependent growth. The first changes seen are growth of the oocyte and expansion of the single layer of follicular granulosa cells into a multilayer of cuboidal cells. The decline in luteal phase progesterone and inhibin production by the now-fading corpus luteum from the previous cycle allows the increase in FSH that stimulates this follicular growth.

### Preantral Follicle

During the several days following the breakdown of the corpus luteum, growth of the cohort of follicles continues, driven by the stimulus of FSH. The enlarging oocyte then secretes a glycoprotein-rich substance, the zona pellucida, which separates it from the surrounding granulosa cells (except for the aforementioned gap junction). With transformation from a primordial to a preantral follicle, there is continued mitotic proliferation of the encompassing granulosa cells. Simultaneously, theca cells in the stroma bordering the granulosa cells proliferate. Both cell types function synergistically to produce oestrogens that are secreted into the systemic circulation. At this stage of development, each of the seemingly identical cohort members must either be selected for dominance or undergo atresia. It is likely that the follicle destined to ovulate has been selected prior to this point, although the mechanism for selection remains obscure (Figs 3.2 and 3.3).

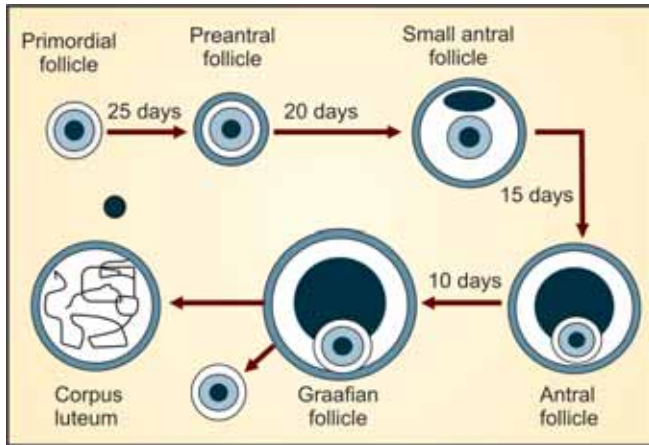


Fig. 3.2: Shows the stages of how a primordial follicle and its further development occur

### Two-cell Two-gonadotropin Theory

The fundamental information of follicular development is the two-cell two-gonadotropin theory. This theory states that there is a subdivision and compartmentalization of steroid hormone synthesis activity in the developing follicle. In general, most aromatase activity (for oestrogen production) is in the granulosa cells. Aromatase activity is enhanced by FSH stimulation of specific receptors on these cells. However, granulosa cells lack several enzymes that occur earlier in the steroidogenic pathway and require androgens as a substrate for aromatization. Androgens, in turn, are synthesized primarily in response to stimulation by LH, and the theca cells possess most of the LH receptors at this stage. Therefore, a synergistic relationship must exist: LH stimulates the theca cells to produce androgens (primarily androstenedione) which, in turn, are transferred to the granulosa cells for FSH-stimulated aromatization into oestrogens. These locally produced oestrogens create a microenvironment within the follicle that is favorable for continued growth and nutrition. Both FSH and local oestrogens serve to further stimulate oestrogen production, FSH receptor synthesis and expression, and granulosa cell proliferation and differentiation.

### Follicular Phase

There are three phases of oocyte maturation which is:

- a. Recruitment
- b. Maturation
- c. Dominance

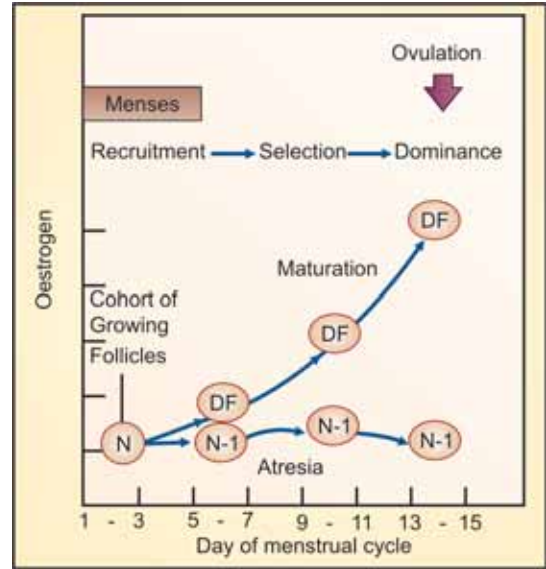


Fig. 3.3: Follicular recruitment and dominance

As shown in the Figure 3.3 to get one dominant follicle the process starts several weeks before. It starts with the recruitment of the follicles and then at the time of menstruation selection of a cohort of follicles are done from which one becomes a dominant follicle. Hence to get one dominant follicle so many follicles are activated but many of them become atretic.

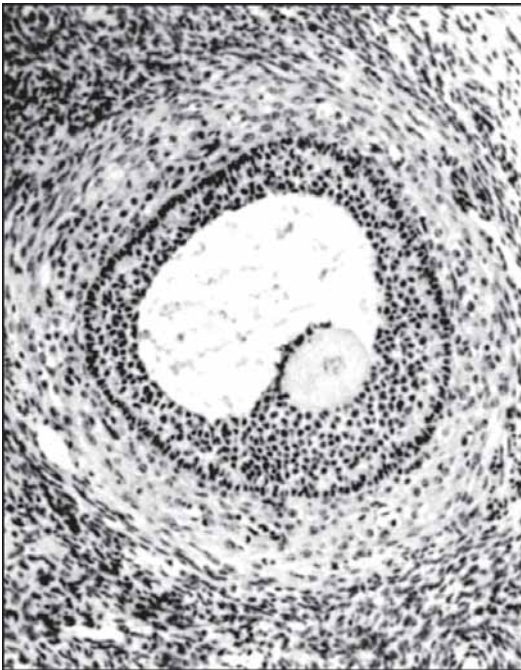
In a graafian follicle there are different functions in granulosa cells (inner cell layer) and theca cells (outer cell layer) and hence two cell theory for gonadotropins has been described. Androgens have two different regulatory roles in follicular development. At low concentrations (i.e., in the early preantral follicle), they serve to stimulate aromatase activity via specific receptors in granulosa cells. At higher levels of androgens, there is intense 5 $\alpha$ -reductase activity that converts the androgens to forms that cannot be aromatized.

Thus the androgenic microenvironment inhibits the expression of FSH receptors on the granulosa cells, thereby inhibiting aromatase activity and setting the follicle on the path to atresia. Meanwhile, as the peripheral oestrogen level rises, the circulating FSH levels decrease because of the negative feedback on the pituitary and hypothalamus. Increased ovarian production of inhibin further decreases FSH production at this point.

The falling FSH level that occurs with the progression of the follicular phase represents a threat to continued follicular growth. The dominant follicle has the most

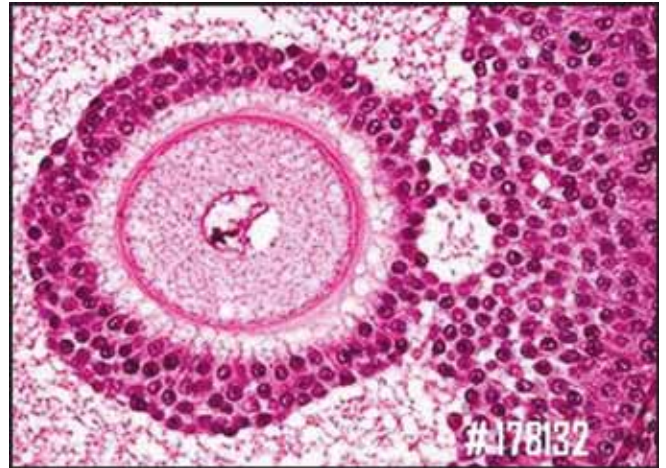
receptors and has the rich oestrogenic microenvironment. As it grows and develops, the follicle continues to produce oestrogen, which results in further lowering of the circulating FSH and creating a more adverse environment for competing follicles. This process continues until the cohort of follicles undergo atresia other than the dominant follicle. With the increasing oestrogen the LH surge occurs and ovulation is seen.

The normal state of an ovum awaiting release from the adult ovary is that of a primary oocyte surrounded by one or two layers of flattened granulosa cells. The commencement of ripening of a follicle is heralded by an increase in size of the ovum and of its nucleus. Thereafter, the surrounding granulosa cells become cuboidal and multiply quickly to become many layered. At the same time, they begin to secrete *liquor folliculi*, a colourless viscid alkaline fluid which contains proteins, globules of fat and small amounts of the various ovarian hormone products, which form small pools separating groups of cells. These pools (*Call-Exner bodies*) later run together to form a single lake and the system becomes a *graafian follicle* (Figs 3.4 to 3.6 and 3.13). This cystic structure is lined by several layers of granulosa cells which are collectively called the *membrana granulosa*.

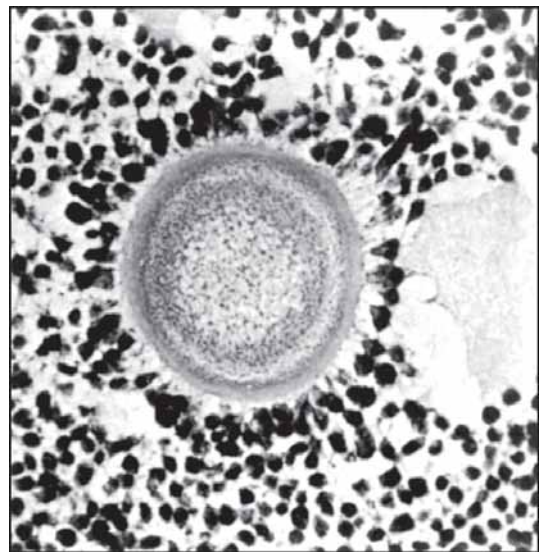


**Fig. 3.4:** A ripening graafian follicle. The granulosa cells are many layers thick and liquor folliculi forms one central pool. The ovum is in the discus proligerus. Outside the membrana granulosa is the active theca interna layer

At one point they project into the cyst as the *discus proligerus (cumulus oophorus)*. This clump of cells contains the ovum itself which at this stage is surrounded by a pale-staining non-cellular, porous area of glyco-proteins - the *zona pellucida*. Between the ovum and the zona pellucida is the *perivitelline space*. The granulosa cells immediately around the ovum constitute the *corona radiata*. Outside the membrana granulosa, the stroma



**Fig. 3.5:** The wall of a ripe graafian follicle lined by granulosa cells with theca interna within and externa without. Tangential cutting of the section has resulted in the omission of the attachment of the discus proligerus to the wall of the follicle



**Fig. 3.6:** A high-power view of the ovum seen in Fig. 3.5. The zona pellucida and its surrounding corona radiata of granulosa cells are well shown. The space on the right of the ovum represents the pre-atrium

cells become differentiated (possibly as a result of a stimulus provided by granulosa cells) into a vascular layer of spindle-shaped cells - the *theca interna*. Outside this again the stroma cells are compressed and modified to form a false capsule; this is called the *theca externa*.

During the process of ripening, the graafian follicle, by asymmetrical development seen particularly in the form of a cone-shaped theca interna (Fig. 3.7), makes its way to the surface of the ovary, easily piercing the tunica albuginea. It thus arranges itself so that the discus proligerus with the ovum lies on the side of the follicle adjacent to the peritoneal cavity.

The hormonal changes which bring about this development are as follows:

At the beginning of a cycle, several ova in both ovaries begin to ripen independent of hormonal influence. A rise in FSH levels stimulates the growth of follicles to the pre-antral stage. While FSH receptors are present only on the granulosa cells, LH receptors are present exclusively on the theca cells. In response to LH, thecal cells are stimulated to produce andro-gens. In the granulosa cells, these androgens are converted to oestrogens by FSH-induced aroma-tization. Thus FSH alone will lead to folliculogenesis but the presence of LH is also essential for steroido-genesis. This is called the 'two-cell, two-gonadotrophin' theory.



**Fig. 3.7:** The theca cone said to be found on one side of a ripening graafian follicle. The membrana granulosa also streams into the cone. This asymmetrical development may explain how the ripening follicle finds its way to the surface of the ovary. (By courtesy of E.G. Strassman and publishers of *Am J Obstet Gynecol*)

Consequent to selection of the dominant follicle, peripheral levels of oestradiol begin to rise significantly by day 7. The rising levels of oestradiol so produced exert a negative feedback on the pituitary secretion of FSH. Autocrine and paracrine regulation also suppress FSH. Inhibin is an important inhibitor of FSH secretion while follistatin suppresses FSH activity by binding activin which is thought to be a stimulatory peptide. The decline in FSH leads to a decline in aromatase activity which leads to atresia of the lesser follicles (apoptosis or naturally programmed cell death). Only the dominant follicle, which is the largest with more granulosa cells and FSH receptors, can maintain its growth at the low FSH levels. FSH stimulates the production of oestrogen from the follicle which further maintains its growth by paracrine action. Thus, through a variety of mechanisms, only one ovum matures and is discharged each month (Fig. 3.8).

The mid-follicular rise in oestradiol exerts a positive feedback effect on LH secretion. The steady rise in LH levels during the late follicular phase stimulates androgen production in the theca cells which results in further oestrogen production in the granulosa cells of the dominant follicle. Once a threshold concentration of oestradiol is achieved, it induces the LH surge.

LH initiates progesterone production in the granulosa layer. The preovulatory rise in progesterone facilitates the positive feedback action of oestradiol and induces a mid-cycle FSH peak. A mid-cycle increase in androgens also occurs; these are derived from the thecal tissue of lesser, unsuccessful follicles.

In the presence of FSH, oestrogen becomes the dominant substance in the follicular fluid whereas androgen dominates in the absence of FSH. LH is not normally present in follicular fluid until the mid-cycle. In the presence of prematurely elevated LH in plasma and in antral fluid, mitotic activity in the granulosa cells decreases, degenerative changes ensue and the intra-follicular androgen level rises. This is the picture seen, for example, in the polycystic ovary syndrome. Antral follicles with the highest oestrogen concentration and lowest androgen: oestrogen ratios are most likely to contain a healthy oocyte.

Follicular ripening does not take place at an even rate throughout the earlier 14 days and the major histological changes only appear within the last few hours or days. An immature follicle is only 0.03 mm (30  $\mu$ m) in diameter. A ripe follicle is 5-8 mm in diameter, and may reach 16-24 mm immediately before rupture, so it is visible to the naked eye.

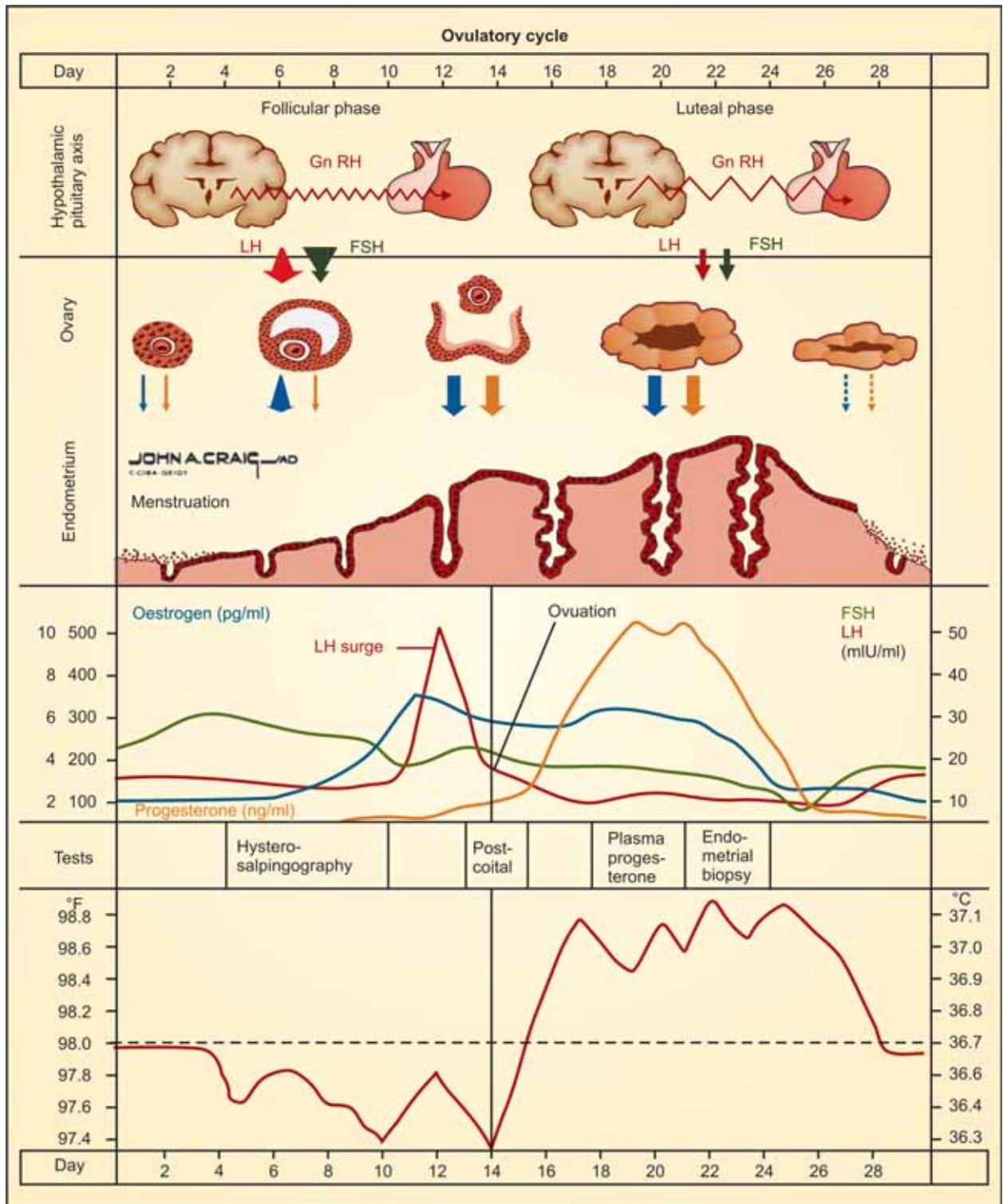


Fig. 3.8: Hormone levels and peripheral effects



Preovulatory follicles are characterized by a fluid-filled antrum that is composed of plasma with granulosa-cell secretions. The oocyte remains connected to the follicle by a stalk of specialized granulosa known as the cumulus oophorus.

Rising oestrogen levels have a negative feedback effect on FSH secretion. Conversely, LH undergoes biphasic regulation by circulating oestrogens. At lower concentrations, oestrogens inhibit LH secretion. At higher levels, however, oestrogen enhances LH release. This stimulation requires a sustained high level of oestrogen (200 pg/ml) for more than 48 hours. Once the rising oestrogen level produces positive feedback, there is an LH surge. In the dominant follicle LH receptors are induced on the granulosa cells. Thus, exposure to high levels of LH results in luteinization of the granulosa cells, production of progesterone, and initiation of ovulation. In general, ovulation will occur in the single mature, or Graafian, follicle 10 to 12 hours after the LH peak or 34 to 36 hours after the initial rise in midcycle LH.

The sex steroids and one of the peptide inhibin are involved in the regulation of follicular development. Inhibin, is secreted in two forms: inhibin A and inhibin B. Inhibin B is secreted primarily in the follicular phase, and is stimulated by FSH, whereas inhibin A is mainly active in the luteal phase. Both forms act to inhibit FSH synthesis and release. The second peptide, activin, stimulates FSH release from the pituitary gland and potentiates its action in the ovary. It is likely that there are numerous other intraovarian regulators similar to inhibin and activin, each of which may play a key role in promoting the normal ovulatory process. Some of these include insulin-like growth factor (IGF)-1, epidermal growth factor (EGF)/transforming growth factor (TGF)- $\alpha$ , TGF- $\beta$ 1,  $\beta$ -fibroblast growth factor (FGF), IL-1, TNF- $\alpha$ , OMI, and renin-angiotensin.

## Maturation of the Ovum

### *Meiotic Arrest of Oocyte and Resumption*

Meiosis (the germ cell process of reduction division) is commonly divided into four phases: prophase, metaphase, anaphase, and telophase. The prophase of meiosis I is further divided into five stages: leptotene, zygotene, pachytene, diplotene, and diakinesis.

Oogonia differ from spermatogonia in that only one final daughter cell (oocyte) forms from each precursor cell, with the excess genetic material discarded in three polar bodies. When the developing oogonia begin to

enter meiotic prophase I, they are known as primary oocytes. This process begins at roughly 8 weeks of gestation. Only those oogonia that enter meiosis will survive the wave of atresia that sweeps the foetal ovary before birth. The oocytes arrested in prophase (in the late diplotene or “dictyate” stage) will remain so until the time of ovulation, when the process of meiosis resumes. The mechanism for this mitotic stasis is believed to be an oocyte maturation inhibitor (OMI) produced by granulosa cells. This inhibitor gains access to the oocyte via gap junctions connecting the oocyte and its surrounding cumulus of granulosa. With the midcycle LH surge, the gap junctions are disrupted, granulosa cells are no longer connected to the oocyte, and meiosis I is allowed to resume.

All the primary oocytes in the ovary of a newborn baby are already in the early stages of the meiotic (reduction) division. The process becomes arrested in the late prophase stage and remains dormant (diplotene stage) until follicular ripening is established. Then, as a result of the mid-cycle preovulatory LH surge, meiosis is resumed and is completed within the 35-45 hours prior to the ovum leaving the follicle. This first maturation division, during which the number of chromosomes in the nucleus is halved, results in the formation of a secondary oocyte and a polar body.

The latter comes to lie in the perivitelline space of the oocyte. The second division, which results in the oocyte casting off another polar body and in the first polar body dividing into two (to make three in all), only occurs after the ovum is liberated and probably only after it is fertilized.

During maturation, the ovum increases in diameter from 0.02 to 0.1 mm and, at the end, its nucleus is off-centre and displays a prominent nucleolus.

## Rupture of the Follicle—Ovulation

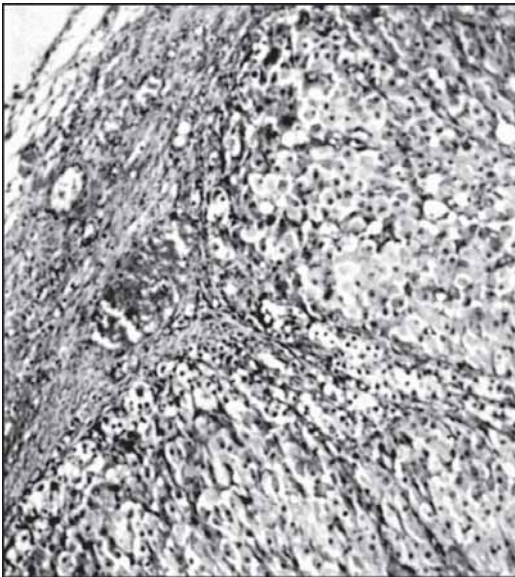
The word rupture implies an explosive or dramatic occurrence, but the discharge of the ovum from the follicle is a comparatively gradual process occupying many seconds if not minutes during which the ovum, still surrounded by a corona radiata of variable thickness, oozes out. It occurs as a result of thinning and degeneration of the cyst wall, this being associated with the production of proteolytic enzymes, the activity of which is enhanced by progesterone. The progesterone-induced mid-cycle rise in FSH also serves to free the oocyte from its follicular attachments. Plasminogen

activators activate plasmin which generates active collagenase leading to degeneration of the collagen in the cell wall, especially at the follicular apex or stigma. Exit of the ovum may possibly be encouraged by contraction of micromuscle cells present in the theca externa and the stroma, these being activated by prostaglandins which are said to be essential to follicle rupture and the ovarian content of which is increased by the action of LH. The follicular fluid escapes with the ovum and, occasionally, slight bleeding takes place from the site of rupture. As the time for ovulation approaches, the outer end of the fallopian tube moves towards the ovary so that the fimbriae tend to embrace it and are ready to catch the ovum. Peritoneal currents also tend to waft the ovum into the tube so it rarely gets free into the peritoneal cavity. This 'pick up' function of the tube is vital to fertility.

Unless fertilized, the ovum survives only 12-24 hours and then disintegrates in the tube without leaving any trace. Nevertheless, ova have been recovered from the fimbria and from the lumen of the tube 2-4 days after ovulation, and from the uterus 4-5 days after ovulation. Such, if not already fertilized, are probably degenerate and are certainly incapable of being fertilized.

### Luteal Phase

Immediately after the ovum is discharged, profound changes take place in the wall of the follicle. The cyst



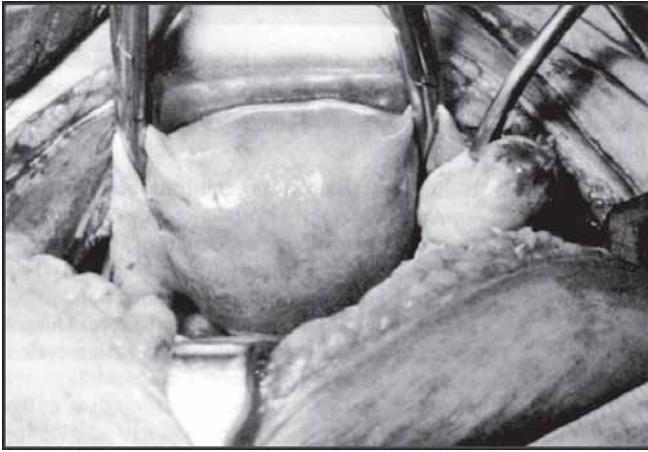
**Fig. 3.9:** The edge of an active corpus luteum, with connective tissue containing blood vessels running between two folds

collapses and the lining cells undergo *luteinization*, a process in which they enlarge by imbibing fluid (Fig. 3.9). Their bloatedness causes them to become closely packed and makes their nuclei look relatively small. Luteinization, which is brought about by enzyme action, affects both the granulosa layer (*granulosa lutein cells*) and the theca interna (*theca lutein cells*), the latter being more prominent in the early stages and the former in the later stages. Indeed, luteinization of the theca is often apparent before ovulation occurs. Apart from increasing in size, the cells also proliferate and the total effect is to enlarge the original follicle until the new structure, *the corpus luteum*, is 1-2 cm in diameter and projects from the surface of the ovary (Figs 3.10 and 3.11). Some of the expansion is taken up by the layers of cells folding into the old cavity and this gives the corpus luteum its characteristic crenated shape on section (Fig. 3.12). The fluid within the cells is rich in phospholipid, cholesterol and carotene. The mature structure has a yellow colour on naked-eye examination because of the presence of lipoids. In its early stages, the corpus luteum is grey or greyish yellow.

Within 2-3 days of ovulation, the corpus luteum becomes supplied with blood vessels which grow down the core of each invagination from the theca interna. During this process there is often a little bleeding into the cavity where the blood mixes with remaining liquor to form a pale red coagulum and makes the whole structure appears red or orange -the '*corpus haemorrhagicum*'. The development of the corpus luteum is completed in 5 days during which time it is already



**Fig. 3.10:** Two recent corpora lutea, one in each ovary, found at operation. This indicates simultaneous ripening of two ova, a phenomenon which is unusual but which explains binovular twinning. The uterus is enlarged by multiple myomas



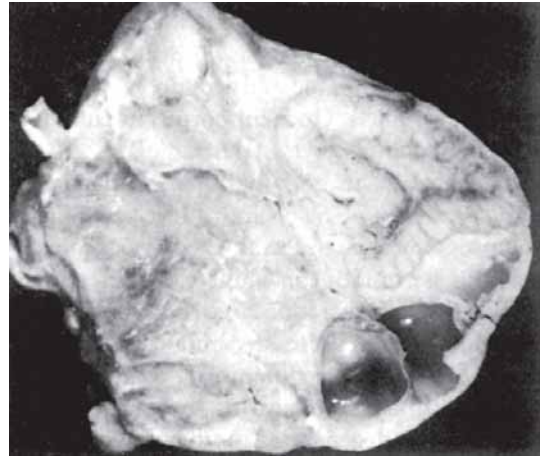
**Fig. 3.11:** A single corpus luteum associated with an 8 weeks' pregnancy (10 weeks' amenorrhoea). Photograph taken prior to Wertheim's operation for carcinoma of the cervix

functioning. Its activity is at a maximum during the following 3 or 4 days, but wanes thereafter as degenerative changes commence 4-6 days before the next menstrual period. This is another example of apoptosis.

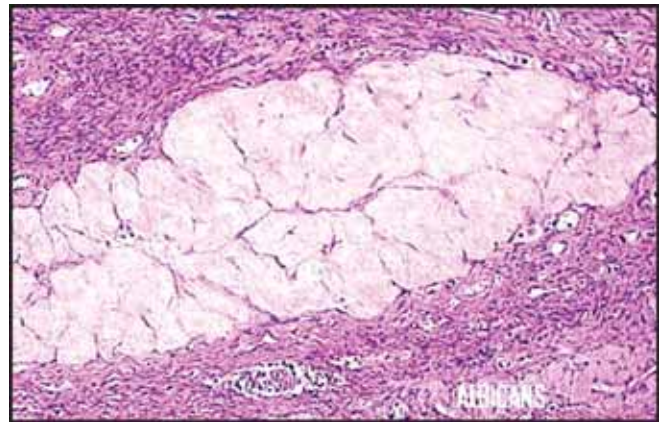
Degeneration is first made evident by the cells becoming vacuolated; thereafter they lose their staining capacity. Colloid degeneration and fatty change are described but these are followed by hyalinization so that ultimately the corpus luteum is converted into hyaline tissue. It is then known as a *corpus albicans*.

Although yellow staining may linger for a long time, the typical corpus albicans is white and structureless. However, it preserves the crenated outline (Fig. 3.13). It is absorbed over the course of 6-12 months, a process so slow that an ovary, on section, always shows several corpora albicantia in varying stages of dissolution. Thus the life cycle of a corpus luteum has four stages: proliferation, vascularization, maturity, and degeneration.

The mid-cycle rise in FSH ensures sufficient LH receptors and is therefore essential for normal luteal function. In the luteal phase, progesterone acts centrally and within the ovary to suppress the growth of the new follicle. Once the corpus luteum degenerates, circulating levels of oestradiol, progesterone and inhibin decline. With the decline in inhibin levels, FSH starts rising. The declining levels of oestradiol and progesterone releases the negative feedback on the pituitary resulting in an increase in frequency of GnRH pulsatile secretion. As a result of increased GnRH pulses and decreased inhibin and oestradiol, there is a greater secretion of FSH compared to LH. Thus, within a few days of the corpus



**Fig. 3.12:** A normal ovary cut across to show a recent corpus luteum which is situated above two atretic follicles



**Fig. 3.13:** A corpus albicans of homogenous hyaline tissue which still preserves the crenated outline characteristic of the corpus luteum

luteum beginning to degenerate, another follicular phase commences in the ovary and the whole process is repeated.

If the ovum which is discharged into the tube happens to be fertilized, its trophoblast starts secreting human chorionic gonadotrophin (hCG) within 7 days and this ensures that the corpus luteum does not degenerate and that the ovarian cycle is arrested.

### Follicular Atresia

Most of the primary oocytes are destined never to mature and they all disappear by the time of the menopause or soon after. Their loss is accounted for mainly by atresia

of the follicles, a process which occurs throughout life, and is particularly noticeable before birth, during childhood and in pregnancy. During these there is what appears to be an unsuccessful attempt at ripening. If the ovum is blighted at an early stage, the primordial follicle is merely obliterated and is gradually replaced by connective tissue. If the ripening proceeds further before the oocyte disintegrates by pyknosis and chromatolysis, a small cyst forms lined by granulosa cells which are sometimes surrounded by theca lutein cells and these may function for a few days. They then undergo atrophy and the whole structure is converted to a *corpus fibrosum* or *corpus atreticum* which ultimately reverts to stromal connective tissue (Figs 3.14 to 3.16).

Atresia accounts for the 'cystic' ovaries commonly seen in children, and even in newly born babies, as well as many of those seen in the adult. It has no pathological significance. The occurrence of atresia, however, is probably of some importance because it may be a means whereby the ovary produces hormones in small amounts in individuals who are neither ovulating nor menstruating. The theca lutein cells of atretic follicles for example are possible sources of the oestrogen produced by the ovary during the few years preceding puberty.

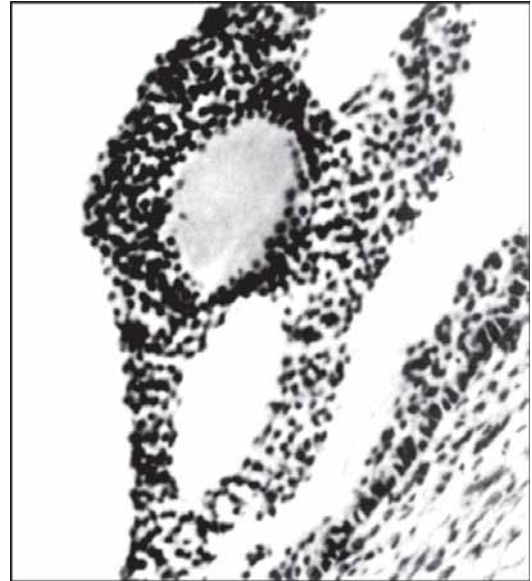
## OVARIAN HORMONES

The endocrine activity of the ovary is mainly concerned with the production of oestrogens and progesterone but also results in the liberation of androgens. The gonad, like the adrenal, is bisexual.

In the adult woman both the ovary and the adrenal cortex each produce, directly or indirectly, 0.05-0.2 mg



**Fig. 3.14:** A graafian follicle in the early stages of atresia. This is a biopsy specimen taken from a woman suffering from amenorrhoea caused by an androgenic adrenal cortical tumour



**Fig. 3.15:** An enlargement of one part of Fig. 3.14 showing the discus proligerus with degenerative changes in the ovum



**Fig. 3.16:** A cyst representing the late stage of atresia of a follicle. The lining consists of a single layer of low cuboidal cells

*testosterone* in 24 hours as well as weaker androgens such as *androstenedione* and *dehydroepiandrosterone*. The plasma testosterone levels of normal females range from 20-80 ng/dl, compared with values of 280-840 ng/dl for normal males.

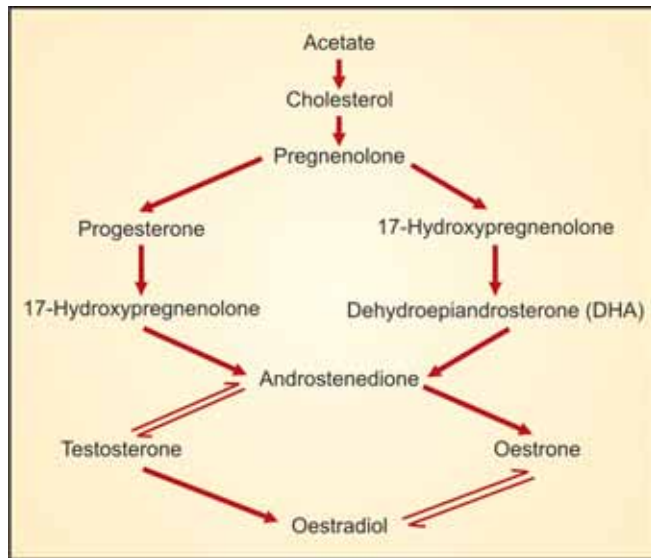
Each of the ovarian hormones was once thought to have a specific tissue origin, oestrogens from granulosa cells, progesterone from thecal lutein cells, and androgens from thecal cells. It is now reasonably well established that any of the special tissues, all of which have a common mesenchymal origin, can under different circumstances produce any of the hormones. Even after the menopause, steroidogenesis may be continued at a low level by the stromal or hilus cells of the ovary.

All the steroid hormones are chemically interchangeable and, in both the ovary and the adrenal cortex, are metabolised from cholesterol (Fig. 3.17). Cholesterol is converted to *progesterone* which can change to *oestradiol* and *oestrone*, intermediate products being *androstenedione* and *testosterone*.

## OESTROGENS

### Production

The main and most powerful oestrogen produced by the ovary is oestradiol but the less active oestrone is also secreted and both are found in circulation. They are



**Fig. 3.17:** The several pathways whereby oestrogens are synthesized from cholesterol, via progesterone and androgens. This represents the normal metabolism and interchangeability of steroid hormones in the ovary and testis, and probably in the adrenal cortex too

inactivated by the liver and their metabolites are excreted in the urine and faeces. When liver function is impaired, the amount of active oestrogen in circulation is increased and excessive menstrual bleeding can result. The most important metabolite is *oestriol* which has a low degree of biological activity. This and many other oestrogens found in the urine are conjugated with glucuronic acid and, in this form, they are inert.

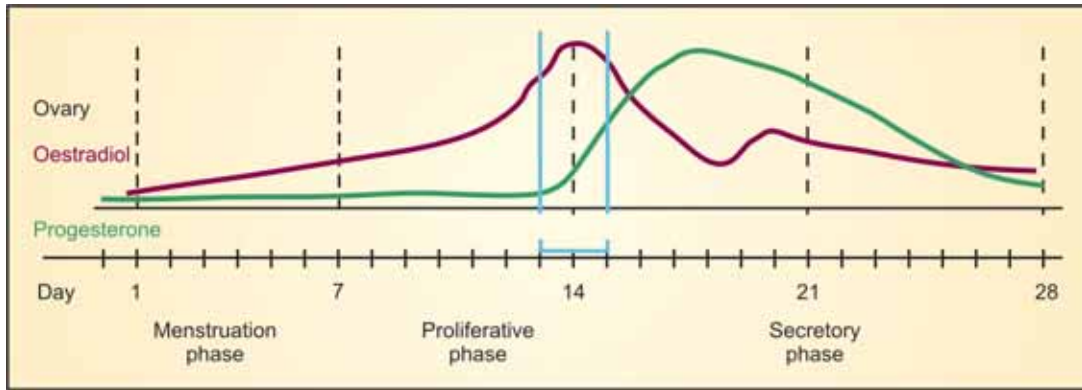
Oestradiol is produced by the granulosa and theca cells in increasing amounts as the follicle ripens. The former have FSH receptors and the latter have LH receptors. In response to LH, thecal cells produce androstenedione and testosterone. These are then converted to oestrogens in the granulosa cells by a process of FSH-induced aromatization. Production, at first moderate in amount, reaches a peak just before ovulation; thereafter it falls until the corpus luteum forms and becomes active to give rise to a second but smaller peak. When the corpus luteum degenerates, the output falls sharply (Fig. 3.18).

The total quantity of oestradiol formed during one cycle (almost entirely by the ovulating ovary) is estimated to be 10 mg. Twenty-five per cent of this is excreted in the urine in the form of metabolites.

While oestradiol is the chief hormone in the reproductive years, oestrone is the main hormone in the menopause and oestriol in pregnancy.

### Receptors

All hormones act through receptors on the cell surface. In the case of oestrogen, two receptors have now been identified; the first is now designated as oestrogen receptor-alpha (ER- $\alpha$ ) and the more recently identified one as oestrogen receptor-beta (ER- $\beta$ ). ER- $\alpha$  is the predominant subtype in the uterus and pituitary. ER- $\beta$  seems to be a weak transactivator. It is present in significant numbers in the ovary, testis and prostate and also in the brain, blood vessels and bone. There is a differential expression of these receptor subtypes in different target tissues, e.g. both ER- $\alpha$  and ER- $\beta$  in the breast but only ER- $\beta$  in the brain and cardiovascular system. Different oestrogens also bind differentially, e.g. phytoestrogens preferentially bind ER- $\beta$  rather than ER- $\alpha$ . Even within the same receptor type, different molecules, e.g. oestradiol, tamoxifen and raloxifene, produce different conformational shapes, and therefore different effects, which are not just positive or negative effects but a whole spectrum of agonistic and antagonistic actions.



**Fig. 3.18:** Plasma levels of oestradiol and progesterone in relation to the menstrual cycle. The basic level of oestradiol in the plasma starts to rise on about the 8th to 9th day to reach a peak in mid-cycle, just before the gonadotrophin peaks. A second oestrogen peak, which is broader and more variable, occurs in the second half of the cycle and reflects corpus luteum activity. The plasma level of progesterone during the follicular phase is low. It rises mainly after ovulation as a result of corpus luteum activity and falls 2-3 days before the onset of menstruation

This is the basis of developing selective oestrogen receptor modulators (SERMs) which will produce the desired action without the side-effects.

## Actions

### Oestrus

The characteristic action of oestrogen is that it induces sexual heat or *oestrus* in 'lower animals'. In women, it plays only a small part in determining sexual desire, the basis for which is neurological as much as endocrinological. Even in other animals the effect of oestrogen on behaviour such as migration and mating is mediated through the central nervous system.

### Secondary Sex Characters

It was formerly thought that oestrogen was the sole cause of female physical and mental characteristics and so it was regarded as the *female sex hormone*. Even though it is now recognized that several other hormones play a part, oestrogen has a major role in determining feminine sensitivity and shyness, feminine curves, soft skin and luxuriant scalp hair. It is of prime importance to the development of the breasts at puberty but not so much to the growth of body hair, not even the so-called female pattern of hair on the lower abdomen and pubes. The development of axillary and pubic hair in both sexes is governed more by androgens which, in the female, are probably of adrenal origin. In male animals, including human beings, oestrogens tend to induce feminine characteristics.

## Secondary Sex Organs

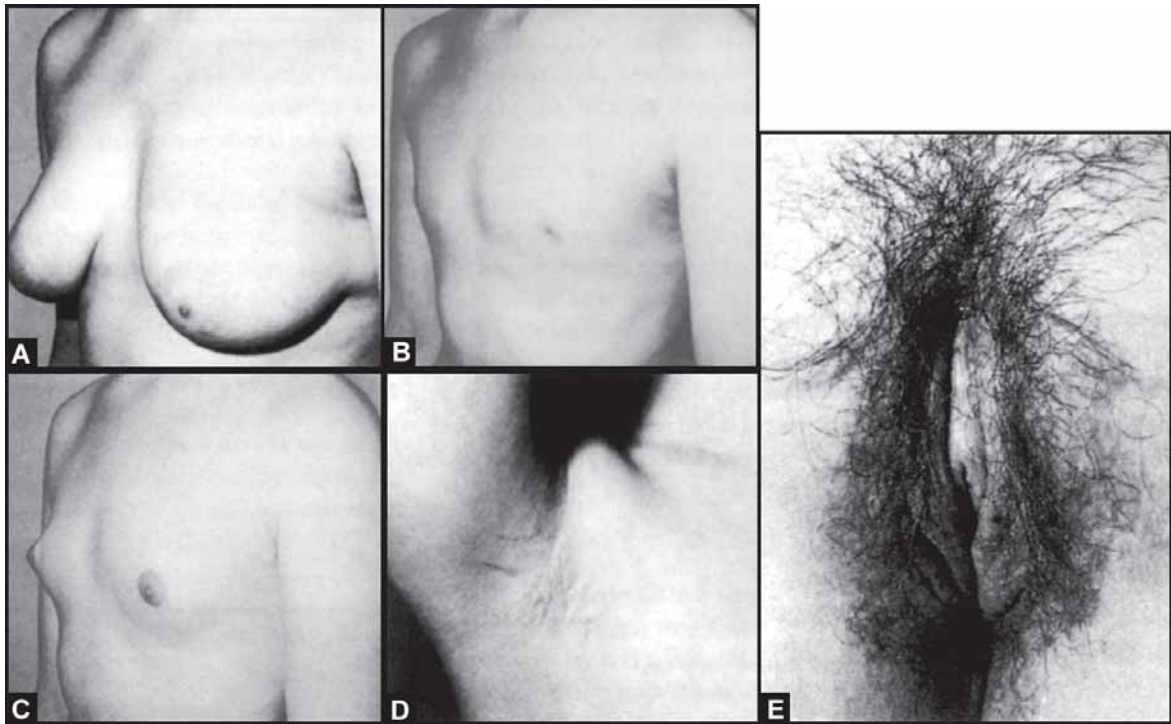
The main action of oestrogens is stimulation of the development of the *secondary sex organs* – vulva, vagina, uterus, fallopian tubes and breasts (Figs 3.19A to E). Their action is selective, being mediated through special receptors and having the effect of stimulating local cell division and metabolism by way of specific RNA synthesis.

### Vulva and Vagina

The vulva and vagina are developed and maintained by oestrogens, and the same is true of the involuntary muscular and fascial tissues associated with them. Oestrogens increase their vascularity and stimulate epithelial activity. It is responsible for the deposition of glycogen in the vaginal epithelium and therefore for vaginal acidity it encourages cornification of superficial vaginal cells to give a characteristic vaginal smear.

### Uterus

The primary effect of oestrogens on the uterus is to increase its vascularity and because of this, as well as of its direct action on tissue cells, it leads to hypertrophy of the myometrium and the endometrium. Oestrogens change the uterus from the infantile to the adult form and the withdrawal of their influence at the menopause leads to atrophy of all elements. In the absence of oestrogens, the myometrium loses its power to contract; in their presence, it contracts regularly and forcefully and is sensitive to oxytocic drugs.



**Figs 3.19A to E:** The part played by the gonad in the development of secondary sex characters. (By courtesy of the Editor, *J Obstet Gynaecol, Br Commonw*). (A) The bust of a girl aged 18 years who had had both ovaries removed at the age of 15 years. By that time the breasts had developed and deprival of ovarian function did not lead to their becoming smaller. The tiny nipples, however, are evidence of atrophy of the duct and glandular systems, (B) Hypoplasia of the breasts of a girl aged 19 years who had had both ovaries removed at the age of 12 years, that is, before the breasts had developed, (C) The same pattern as (b) with the breasts developing as the result of oestrogen therapy, (D) The same patient as (b) and before hormone therapy; axillary hair is well grown despite absence of ovarian function, (E) The vulva of a girl aged 18 years who had had ovarian function destroyed at the age of 10 years and who had not had any replacement therapy. Despite this the pubic hair was formed quite well. Pubic and axillary hair reflect adrenal rather than gonadal activity

Oestrogens cause proliferation of endometrial glands and growth and compaction of the stroma. They restore the endometrium, including its coiled arteries, after menstruation, but do not induce the glands to secrete. An endometrium suddenly deprived of an oestrogen influence breaks down and bleeds.

The cervix also hypertrophies under the influence of oestrogens and atrophies when they are withdrawn. The growth and secretory activity of cervical epithelium are determined, at least in part, by oestrogens.

#### *Fallopian Tubes*

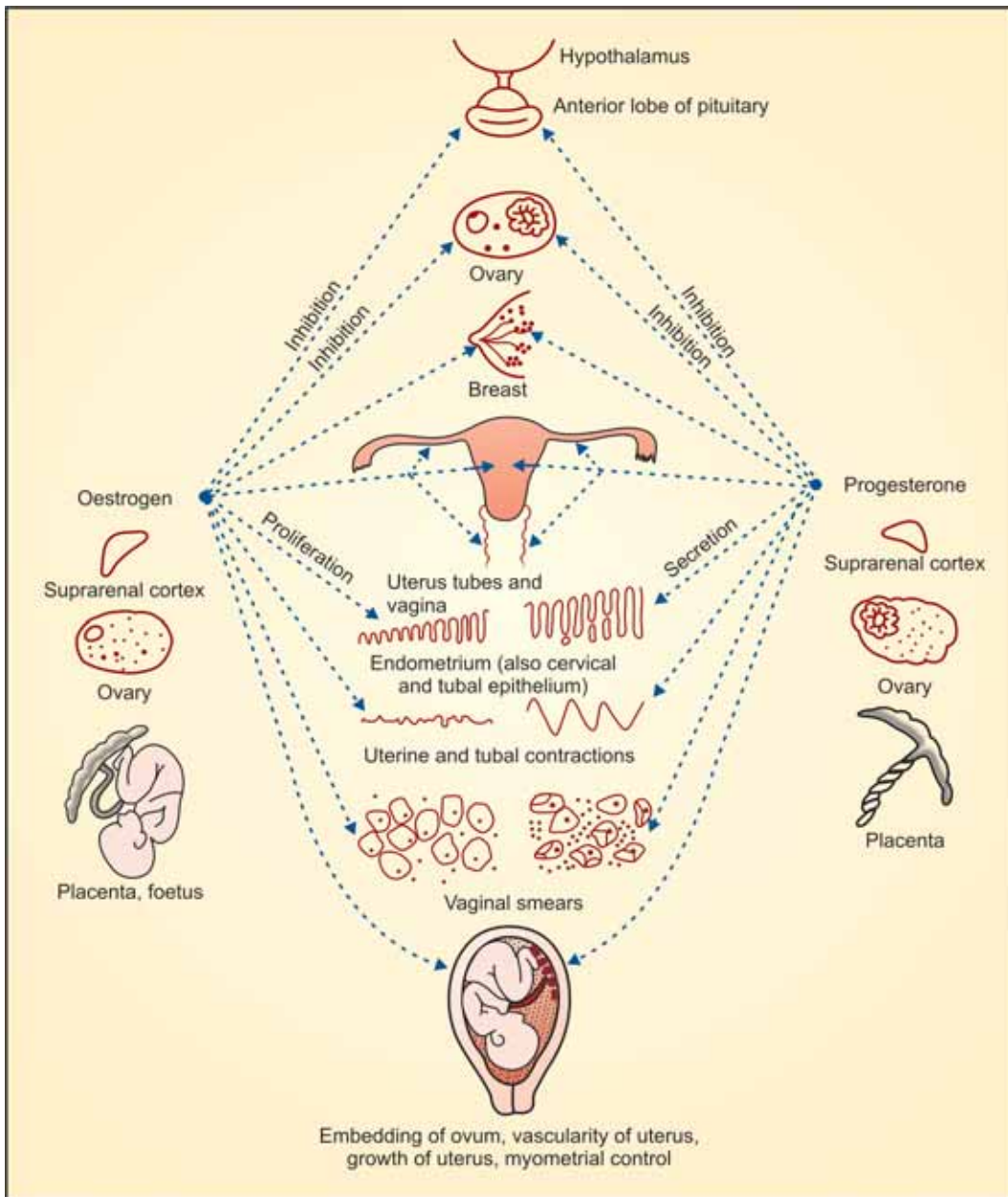
These respond to oestrogens by increased vascularity, hypertrophy and peristaltic movements of the muscle; and by enhanced ciliary and secretory activity of the endosalpinx.

#### *Breasts*

The breasts also respond to oestrogens by increased vascularity, enlargement, pigmentation of the areola and epithelial growth; the last is seen mainly in the lacteal ducts and nipple, rather than in the acini. No matter how great the stimulus, oestrogens do not cause lactation in women, they inhibit it.

#### *Endocrine System*

By controlling the *releasing factors* of the hypo-thalamus, oestrogens depress the output of FSH, but stimulate the production of LH and adrenocorticotrophic hormone (ACTH). Oestrogens inhibit follicular activity in the ovary, indirectly through the hypothalamus and pituitary and directly by autocrine mechanisms, on the



**Fig. 3.20:** Diagrammatic representation of the sources and main actions of oestrogens and progesterone. The inhibitory action of oestrogen on the anterior pituitary is probably mainly mediated through the hypothalamus. Although shown here, progesterone has slight if any inhibitory effect on the hypothalamic-pituitary system and then only when large doses are administered or when a progesterone is metabolized to an oestrogen

granulosa cell itself. Oestrogens, by increasing the amounts of binding globulins in circulation, also raise the blood levels of protein-bound iodine and protein-bound cortisol. They decrease glucose tolerance.

### *Skeletal System*

Oestrogens act on both osteoblasts and osteoclasts. They conserve calcium and phosphorus. They also inhibit interleukin-1, tumour necrosis factor (TNF) and



interleukin-6 which are potent stimulators of osteoclastogenesis and bone resorption. The net result is that they encourage bone formation. At puberty they first give rise to a growth spurt. Removal of both ovaries in childhood results in stunted growth. Closure of epiphyses and limitation of stature are mostly the effects of androgens of adrenal origin. After the menopause, lack of oestrogens leads to osteoporosis.

#### *Urinary Tract*

Oestrogen receptors are found in the urethra and bladder. Oestrogens promote urethral resistance and thus improve urethral continence. By maintaining the thickness of the urinary tract epithelium and urethral collagen, as well as by their effect on the vaginal pH, they protect against urinary tract infection. They may also have an action on the sensory threshold of the lower urinary tract. Lowering of this threshold in hypooestrogenism may lead to urge incontinence and nocturia.

#### *Blood*

Oestrogens increase the coagulability of the blood by raising the levels of fibrinogen and of Factors VII, VIII and X, and increasing the adhesiveness of platelets.

#### *General*

Oestrogens, like other steroids, encourage nitrogen, sodium and fluid retention in the body, but their action in this respect is not as strong as that of androgens. They lower the level of blood cholesterol, (especially low-density lipoproteins), and increase the level of high-density lipoproteins. This may have some bearing on the relatively low incidence of coronary thrombosis in premenopausal women. Oestrogens have a limited effect on other epithelia such as those of the nose and skin. They act on dermal fibroblasts and enhance dermal water content, mucopoly-saccharide concentration and collagen content, and improve vascularization. In certain sites, the uterus for example, they cause a release of acetylcholine. They modify liver function slightly but this is generally only revealed by very sensitive tests.

### Progesterone

#### *Production*

Progesterone produced by the ovary is rapidly metabolized by the liver. One of its products excreted in the urine is the biologically inactive *pregnenediol*, but this

accounts for only 10 per cent of the hormone which enters the circulation, the fate of the remainder is largely unknown. Progesterone is secreted mainly by the corpus luteum so its production during the early follicular phase of the cycle is negligible. However, LH initiates luteinization and progesterone production in the granulosa layer. This preovulatory rise in progesterone facilitates the positive feedback action of oestrogen.

Thus progesterone plays a role in inducing the mid-cycle FSH peak, which facilitates the release of the oocyte from its follicular attachment, converts plasminogen to plasmin, a proteolytic enzyme, and ensures adequate LH receptors are available for the luteal phase to proceed normally.

Immediately prior to ovulation, when the theca interna begins to luteinize, and during the luteal phase, the plasma progesterone level rises from 6 to 63 nmol/litre, falling in the next follicular phase to 1.3-6 nmol/litre (Fig. 3.18). The total amount of progesterone produced by the ovary during one menstrual cycle is 300-400 mg.

### Actions

#### *Pregnancy, Maternal Instinct*

Progesterone is essential to the maintenance of pregnancy in animals, hence its name. This may also be true for women but in this case the hormone is produced by the placenta rather than the corpus luteum during all except the early days of pregnancy. In animals, progesterone, by a direct action on the central nervous system, is important in determining certain activities associated with care of the young, such as the preparation of the nest, but this sort of effect is not obvious in the human being.

#### *Secondary Sex Organs*

Progesterone has some effect on all the secondary sex organs but only if they are simultaneously or previously under the influence of oestrogen. Without at least a trace of this hormone, progesterone is ineffective. Some of its effects on the genital tract and the breasts are described into which reference should be made.

#### *Genital Tract*

Progesterone causes changes in the vaginal epithelium and alters the secretory activity of the cervix to influence the physical and chemical properties of its mucus. It

raises the muscle tone and sphincter action of the isthmus and upper cervix. The main effects of progesterone on the genital tract, however, are seen in the body of the uterus. Here it assists oestrogen in causing hypertrophy of the myometrium, but it also brings about an increase in the number of muscle fibres such as occurs early in pregnancy. It influences spontaneous uterine contractions, tending to make them lower in frequency and tone but higher in amplitude than those produced by oestrogens. It is doubtful whether progesterone has an inhibitory effect on established human myometrial activity. If it has, it is because it blocks the orderly conduction of impulses from one muscle fibre to another. This is said to result from the hormone altering the electrolyte content of the cells.

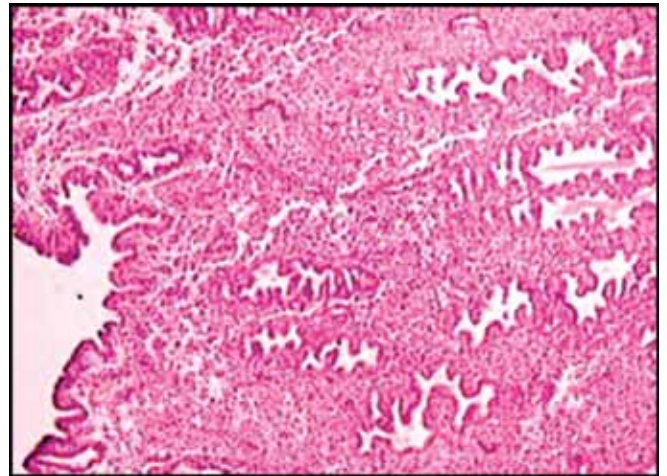
Progesterone increases the thickness of the endometrium by enlarging the glands and by rendering the stroma oedematous. It promotes endometrial enzymatic activity, induces the glands, already proliferated by oestrogen, to secrete and brings about a *decidual reaction* in the stroma. The last is seen mostly in stromal cells near the endometrial surface, especially if they are simultaneously or subsequently exposed to a mechanical stimulus such as is provided by implantation of an ovum. Decidual reaction is characterized by the cells imbibing fluid so that they swell to reveal the cytoplasm and cell walls previously not obvious. The loose network of the endometrial stroma is thus replaced by closely packed polyhedral cells with relatively small nuclei (Fig. 3.21). An endometrium which is suddenly deprived of a progesterone influence disintegrates on its surface and bleeds.

### Breasts

Progesterone acts in conjunction with oestrogen in producing breast development at puberty and during pregnancy. It stimulates the epithelium of the acini rather than that of the ducts, but does not induce lactation.

### Endocrine System

At low levels, progesterone in the presence of oestrogen, exerts positive feedback on the pituitary and is responsible for the FSH surge and for LH secretion. The increased levels of progesterone in the luteal phase exert a negative feedback on the hypothalamus to inhibit GnRH production and consequent gonadotrophin



**Fig. 3.21:** Endometrium in the late secretory phase. The glands have become serrated, the stroma in the upper part of the field shows the changes of a predecidua, and the spiral arteries which lie between the glands are well muscularized and surrounded by a mantle of decidualized cells. (Photomicrograph x95)

release. High levels of progesterone can inhibit ovulation by this mechanism.

### General

The sodium- and fluid-retaining effects of progesterone are similar to those of other steroids. Progesterone promotes the secretion of sebum by the skin and makes scalp hair more greasy; this may explain premenstrual acne and hair changes during pregnancy. Progesterone is thermogenic and raises the body temperature by 0.2-0.5°C (0.4-0.8°F). Progesterone relaxes smooth muscle throughout the body - in the ureters, blood vessels and alimentary tract; this probably accounts for the occurrence of hydroureter, varicose veins, haemorrhoids and constipation during pregnancy.

### Relaxin

Relaxin is a peptide hormone produced by the corpus luteum of pregnancy and perhaps by the human placenta, chorion and decidua as well. It congests and softens the ligaments controlling the joints of the pelvis and lower spine; this allows increased movement during pregnancy and labour. Relaxin has been shown to produce cervical ripening in *in vitro* studies of human cervical stromal cells; in future, recombinant relaxin may be available as a cervical ripening agent.

### Inhibin, Activin and Follistatin

Inhibin, activin and follistatin are peptides with paracrine functions secreted by granulosa cells into the follicular fluid, by the placenta and also in other tissues in the body. These peptides are secreted in response to FSH; in turn they exert feedback on FSH secretion. As the name suggests, inhibin inhibits FSH secretion while activin stimulates it. Follistatin suppresses FSH activity.

### PITUITARY HORMONES

The functions of the genital organs and breasts are controlled by hormones released from the pituitary gland. The output of these is, in turn, determined by the hypothalamus (*see below*), so the pituitary acts to some extent as a storehouse or reservoir.

### Posterior Lobe Hormones

The posterior pituitary (*neurohypophysis*) discharges oxytocin and vasopressin (antidiuretic hormone), both of which cause smooth muscle to contract. Oxytocin stimulates particularly the muscle of the uterus and that of the myoepithelial cells in the breasts and even in a pure synthetic form, has slight vasopressor and antidiuretic effects. Vasopressin maintains blood pressure by controlling arteriolar resistance, stimulates smooth muscle of the bowel and is strongly antidiuretic. It also, even in its pure synthetic form, has a slight oxytocic action.

### Anterior Lobe Hormones

The anterior pituitary (*adenohypophysis*) secretes at least six hormones: follicle stimulating hormone (FSH), luteinizing hormone (LH), prolactin, adrenocorticotrophin (ACTH), growth hormone (GH) and thyroid stimulating hormone (TSH). Melanocyte stimulating hormone (MSH) is thought to be secreted by the middle lobe. Follicle stimulating hormone and LH are collectively called gonadotrophins. Follicle stimulating hormone acts on the granulosa cells in the female and on the sertoli cells in the male. Luteinizing hormone acts on the preovulatory follicle and corpus luteum in the female and on the Leydig cells in the male. The basophil (beta) cells of the adenohypophysis are credited with the production of FSH and LH, the acidophil (alpha) cells with the production of prolactin and GH. The chromophobe cells may represent a state

in which, having discharged their secretion, they are temporarily without a capacity to take up stains. Another view is that chromophobes are undifferentiated cells that can give rise to acidophils or basophils.

### Follicle Stimulating Hormone

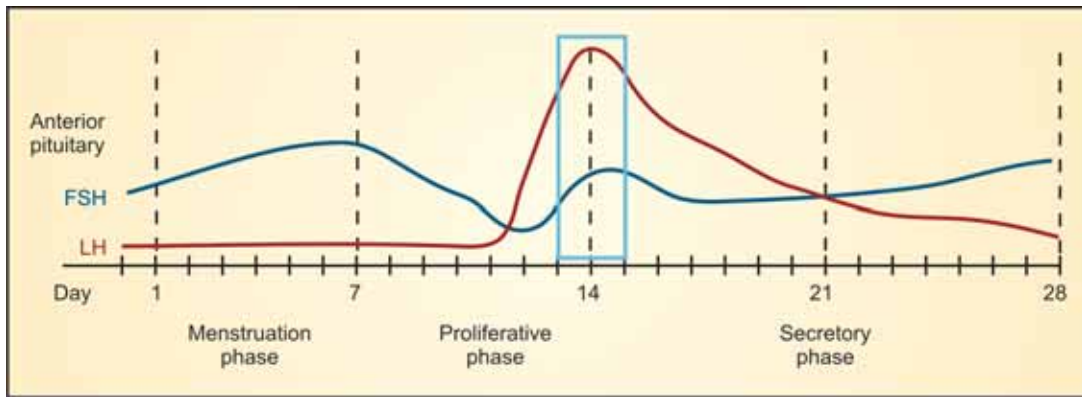
FSH is a glycoprotein which is responsible for the formation and ripening of the graafian follicle and for stimulating it to secrete oestrogen, although in these functions it requires the help of LH. By itself it certainly cannot bring about ovulation. The level of FSH in the plasma shows cyclical changes with peaks when follicular ripening is being initiated and also immediately before ovulation (Fig. 3.22). They play an important role in the menstrual cycle through an inhibitory effect on hypothalamic GnRH secretion. Other pituitary hormones are also modulated by opiates. There are essentially 3 classes of opioids: the endorphins, the enkephalins and the dynorphins. The endorphins are generated mainly in the anterior and middle lobes of the pituitary gland, but also in the hypothalamus and other areas of the brain, in the sympathetic nervous system and in peripheral tissues including the gonads, lungs, placenta and the gastrointestinal tract.

The enkephalins are produced in the posterior pituitary, the brain and spinal cord, adrenal medulla and the gastrointestinal tract and play an important role as inhibitory neurotransmitters in the autonomic nervous system. The dynorphins are found mainly in the hypothalamus and gastrointestinal tract and have potent analgesic and behavioural effects. The endorphin levels are at their lowest in the menstrual phase and at their highest in the luteal phase. Oestrogen and progesterone increase endogenous opiate levels.

The administration of naloxone, an opioid antagonist, increases the frequency and amplitude of GnRH and LH pulses. Naltrexone, which blocks opioid receptors, restores normal ovarian function in hypothalamic amenorrhoea. Even pregnancy has been reported following this therapy.

### Catecholestrogens

Catecholestrogens are formed in the hypothalamus by the conversion of oestrogens by the 2-hydroxylase enzymes. They have a catechol and an oestrogen side and can therefore interact with both systems. Thus they can increase and decrease catecholamine levels. Their



**Fig. 3.22:** Plasma levels of FSH and LH in relation to the menstrual cycle. The heights of the mid-cycle peaks, which are related to ovulation, vary, but that of LH is always more pronounced than that of FSH. During the rest of the cycle the plasma levels of both hormones are fairly constant, although sometimes an extra preovulatory peak of FSH is demonstrable

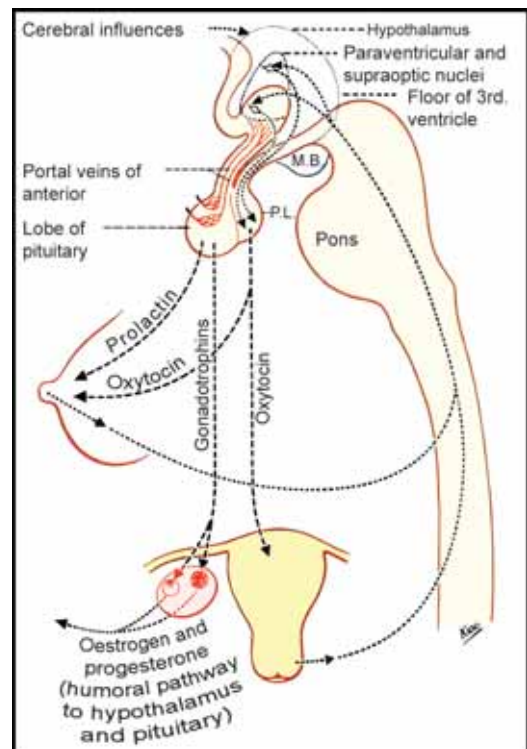
exact mode of action has not been defined but it is postulated that there may be a link between catecholamines and GnRH secretion.

### PITUITARY-HYPOTHALAMIC RELATIONS

There are close anatomical and functional links between the pituitary gland and the hypothalamus. The hypothalamus in humans is the area of the forebrain situated above the pituitary gland and forming the antero-inferior wall and floor of the third ventricle.

It is bounded laterally by the optic tracts and cerebral peduncles and anteriorly by the optic chiasma. The neurohypophysis differs from the adenohypophysis in that it is a secretory and storage unit composed of neural tissue. Anatomically it consists of the supraoptic and paraventricular nuclei of the hypothalamus, in which synthesis of vasopressin and oxytocin occur. The hypothalamo-hypophyseal tract, which conveys the hormones, is controlled by nerve impulses and the hormones are secreted directly into the capillary plexus of veins draining into the cavernous sinus and jugular veins in response to physiological stimuli (Fig. 3.23).

The hypothalamic control of the anterior lobe is achieved via the hypophyseal portal venous system; secretion and synthesis of each anterior pituitary hormone is controlled by releasing and release-inhibiting hormones from the hypothalamic nuclei, which pass down the portal system of capillaries to the adenohypophysis. Secretion of the releasing hormones is controlled by direct feedback or by influences which act via the higher centres. Feedback control is usually inhibitory (negative), i.e. depressing both the releasing



**Fig. 3.23:** Diagrammatic representation of the hypothalamic-pituitary relations. Nerve reflexes from the nipple and cervix can stimulate the release of oxytocin from the hypothalamus and the posterior pituitary via neuron pathways, and possibly the production of prolactin. Ovarian hormones travel by the bloodstream to exert their control on the hypothalamic-pituitary system. Releasing factors or hormones travel from the hypothalamus to the anterior pituitary by way of portal veins. Their output is also determined by influences from the cerebral cortex. M.B. - mammillary body which is not part of the hypothalamus. P.L. - posterior lobe of the pituitary

Table 3.1: Pituitary-hypothalamic hormones

<i>Hypothalamic releasing hormone</i>	<i>Hormone released</i>
Gonadotrophin releasing hormone—GnRH	LH and FSH
Corticotrophin releasing hormone—CRH	ACTH
Growth hormone releasing hormone—GHRH (SRH)	GH (somatotrophin)
Thyrotrophin releasing hormone—TRH	TSH
<i>Hypothalamic inhibiting hormone</i>	<i>Hormone inhibited</i>
Prolactin inhibiting factor—PIF	Prolactin
Growth hormone release inhibiting hormone—GHRH (somatostatin)	GH (somatotrophin)

hormone production and the trophic hormone secretions from the anterior lobe. Positive feedback (stimulatory) is less common but is involved in the secretion of LH in response to high levels of oestrogen and progesterone. The feedback is indirect if it operates on the pituitary via the hypothalamus and direct if the effect is on the anterior lobe itself.

Some of the releasing hormones have been synthesized. A list of the releasing hormones and inhibiting hormones is given in Table 3.1.

Within the central nervous system the control of the releasing factors is mediated by the local synthesis of neurotransmitters — dopamine, serotonin and noradrenaline. These neurotransmitters, apart from controlling hypothalamic neurohormone secretion, are also concerned at other sites including regulation of sexual function, behaviour and mood. There are many other peptides which also function as neuro-transmitters with local regulatory autocrine and paracrine roles. These include neurotensin, which alters pituitary hormone release; vasoactive intestinal peptide, which increases prolactin secretion; angio-tensin II, which controls gonadotrophin and prolactin secretion; endothelins, which cause release of gonadotrophins and inhibit prolactin; somatostatin, which inhibits the release of growth hormone, prolactin and TSH; neuropeptide Y, which is increased in undernutrition, anorexia and bulimia nervosa and may be a link between nutrition and reproductive function; growth factors, which modulate pituitary hormone production and secretion; activin, which augments the secretion of FSH and inhibits prolactin and growth hormones; inhibin, which selectively inhibits FSH, but not LH secretion; follistatin, which decreases the activity of activin; galanin, the endogenous opiates, etc. The response to the neurotransmitters can be modified by various pharmacological preparations.

In exciting or inhibiting the output of pituitary hormones, the hypothalamus can be influenced by higher centres in the brain, especially those in the temporal lobes. So emotional upsets can encourage or depress pituitary and, therefore, ovarian and menstrual functions.

The hypothalamus is also affected by environmental factors and this is especially evident in animals. Thus, increasing or decreasing hours of daylight affects gonadal activity in many species and can be used to induce or inhibit ovulation. In birds especially, daylight operates via the eyes along a chain which consists of retina → brain → hypothalamus → pituitary → gonad. Exposure to continuous daylight can so disturb the hypothalamic clock in female rats as to bring about persistent oestrus associated with cystic ovaries.

It also appears that the hypothalamus, and indeed the brain, is sexually differentiated in some if not all species. The discharge of gonadotrophins from the male hypothalamic-pituitary system is, excluding hourly variations, continuous and not cyclical. If it were otherwise, spermatogenesis in men would wax and wane. That it does not might be attributable to the fact that testosterone is not so inhibitory to hypothalamic-pituitary activity as are oestrogens. The phenomenon may also reflect a sexual difference in the central nervous system. In some animals, not including the human being, so far as is known, sexual differentiation of this system is determined by the influence of gonadal hormones before or shortly after birth. Thus, if a newborn female rat is given a single injection of testosterone, or if its brain is directly exposed to this hormone, the subsequent discharge of gonadotrophins by its hypothalamic-pituitary system in later life is continuous and not cyclical or intermittent. Moreover, the animal's sexual and other behaviour becomes male rather than female.

There are many loops for control of ovulation. It starts from the hypothalamus which has multiple inter-connections with other regions in the brain. Many of these pathways form feedback loops to areas supplying neural input to the hypothalamus.

The feedback loops (Fig. 3.24) to the hypothalamus exist and are known as the long, short, and ultrashort feedback loops. The long feedback loop is composed of endocrine input from circulating hormones, just as feedback of androgens and oestrogens. Similarly, pituitary hormones may feed back to the hypothalamus and serve important regulatory functions in short-loop feedback. Finally, hypothalamic secretions may directly feed back to the hypothalamus, itself, in an ultrashort feedback loop.

**Gonadotropin-releasing Hormone**

Gonadotropin-releasing hormone (GnRH) (also called luteinising hormone-releasing hormone, or LHRH) is the controlling factor for gonadotropin secretion. It is a decapeptide produced by neurons with cell bodies primarily in the arcuate nucleus of the hypothalamus. GnRH simultaneously regulates the secretion of two hormones—FSH and LH. It is secreted in a pulsatile fashion to be effective, and the pulsatile release of GnRH influences the release of the two gonadotropins. Continual administration does not result in gonadotropin secretion and infact it suppresses the release of FSH and LH. The pituitary gets suppressed with the contiunuous exposure of gonadotropin releasing hormones. Hence a continual exposure of the pituitary gonadotroph to GnRH results in a phenomenon called downregulation, through which the number of gonadotroph cell surface GnRH receptors is decreased. Similarly, intermittent

exposure to GnRH will “upregulate” or “autoprime” the gonadotroph to increase its number of GnRH receptors. This allows the cell to have a greater response to subsequent GnRH exposure. The continual pulsatile secretion of GnRH is necessary because GnRH has an extremely short half-life (only 2 to 4 minutes).

When the amplitude of the GnRH secretion is seen in the follicular phase it is characterized by frequent, small-amplitude pulses of GnRH secretion. In the late follicular phase, there is an increase in both frequency and amplitude of pulses. During the luteal phase, however, there is a progressive lengthening of the interval between pulses as well as a decrease in the amplitude. This variation in pulse amplitude and frequency is directly responsible for the magnitude and relative proportions of gonadotropin secretion from the pituitary.

Over the years the structure of the GnRH molecule has been changed and made into a more useful molecule for management of infertility and other gynaecological conditions. Additional modification of the GnRH molecule results in an analogue that has no intrinsic activity but competes with GnRH for the same receptor site. These GnRH antagonists produce a competitive blockade of GnRH receptors, preventing stimulation by endogenous GnRH and causing an immediate fall in gonadotropin and sex steroid secretion. Antagonists have an advantage of not suppressing the required FSH in the beginning phase of the follicular development unlike the GnRH- $\alpha$  which suppresses both FSH and LH. Compared with that of GnRH agonists, this action greatly reduces the time for therapy to become effective. Thus, as with constant GnRH exposure, downregulation occurs. GnRH agonists are now widely used to treat disorders that are dependent on ovarian hormones. They are used to control ovulation induction cycles and to treat precocious puberty, ovarian hyperandrogenism, leiomyomas, endometriosis, and hormonally dependent cancers. The development of GnRH antagonists proved more difficult, in that a molecule was needed that maintained the binding and degradation resistance of agonists but failed to activate the receptor.

**PITUITARY-OVARIAN RELATIONS (CONTROL OF OVULATION)**

The neurohormonal connections are again illustrated by the control of ovulation in certain animals such as the rabbit. In these, follicular ripening proceeds spontaneously but ovulation only occurs as a result of coitus.

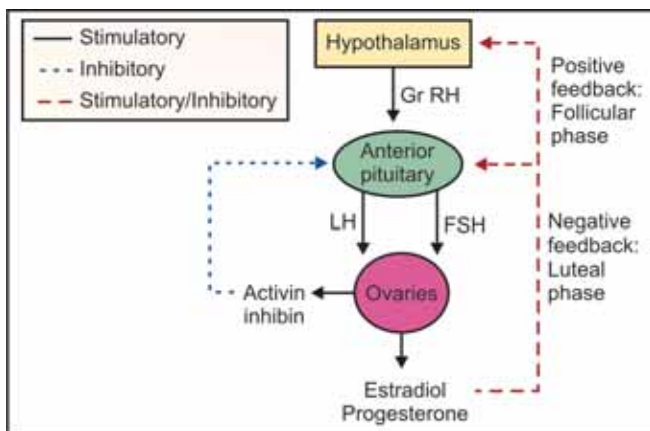


Fig. 3.24: Showing feedback loops

This acts by mechanical stimulation of the cervix. From the cervix, nerve impulses travel through the spinal cord to the hypothalamic-pituitary system which liberates LH to cause ovulation 18 hours after the initial stimulus. In women, ovulation ordinarily occurs independent of coitus and is spontaneous but this does not exclude the possibility that it may sometimes be determined by outside influences. It is timed in relation to the *next* menstrual period which it precedes by  $14 \pm 2$  days - this means that the luteal phase in the ovary is relatively constant in duration whereas the length of the follicular phase varies with the total length of the cycle.

The onset and duration of these phases are determined by a cyclical and sequential discharge of gonadotrophins by the hypothalamic-pituitary system.

Gonadotrophins are found only in small quantities in the anterior pituitary of the foetus and child; significant amounts do not become demonstrable in the urine until the age of 10-12 years. The relative quiet of the ovary during childhood is therefore partly explained by failure of the pituitary to put out gonadotrophins. This in turn is almost certainly because the hypothalamus does not release GnRH, the evidence being the fact that the administration of this factor to a child results in the secretion of FSH and LH by the pituitary. It follows that the awakening of ovarian function at puberty has a hypothalamic basis.

The cyclical production of FSH and LH in the adult woman is itself largely controlled by the ovarian cycle. This is by way of a feedback mechanism which operates through the hypothalamus and which can be explained in a simplified form as follows. This discharge of FSH (and a little LH) from the pituitary, initiated by the hypothalamus, causes a follicle in the ovary to ripen and secrete oestrogen. A resulting high level of oestrogen in circulation increases GnRH-receptor concentration. A surge in GnRH accompanies the LH surge. A high level of LH induces ovulation and corpus luteum formation with a consequent increase in the secretion of progesterone.

The negative feedback on the pituitary operates at both the hypothalamus and anterior pituitary. Oestrogen exerts inhibitory effects at both levels, decreasing GnRH pulsatile secretion and GnRH pituitary response. Progesterone also exerts its inhibitory action at the hypothalamic level. The degeneration of the corpus luteum results in a fall in the level of both oestrogen and progesterone in the circulation, then stimulates

the hypothalamus to put out GnRH to start off the next cycle.

The details of this feedback mechanism are complicated, operating on the pituitary and the hypothalamus. Moreover, oestrogen and progesterone, in different amounts and circumstances, exert either positive or negative effects on the hypothalamus and/or pituitary. Progesterone can first stimulate and then inhibit the production of GnRH. All actions are receptor mediated.

There is evidence to show that a 'short-loop feedback' mechanism also operates between the pituitary and the hypothalamus so that levels of different gonadotrophins influence the discharge of releasing hormone by the hypothalamus. Thus, a high level of LH in the circulation may inhibit the output of GnRH.

The balance between the actions of the hypothalamic-pituitary complex and the ovary is well demonstrated by the fact that, when ovarian function is feeble, the gonadotrophic activity of the pituitary becomes excessive. When both ovaries are removed from an adult woman, the outpouring of gonadotrophins (mainly FSH but also some LH) into the blood and urine continues without break for many months and may even be 5-20 times greater than the peak excretion in the normal menstruating woman.

## HORMONE LEVELS AND ASSAYS

The quantitative assay of many of the hormones and their metabolites in blood and urine was difficult till the development of specific and reliable radio-immunoassay techniques. The tests are still relatively expensive and should only be carried out for specific diagnostic and therapeutic indications. The ability to measure circulating steroid hormones has almost eliminated the need for measuring the urinary metabolic products.

The steroid hormones, their fractions and metabolites found in the blood are assayed by mass. For plasma assays the general rule is to give the amount per millilitre in picograms (pg), nanograms (ng) and micrograms ( $\mu\text{g}$ ) as well as milligrams (1.0 ng/ml is equivalent to 0.1  $\mu\text{g}/100\text{ ml}$  and to 1.0  $\mu\text{g}/\text{L}$ ); or in mIU/ml or IU/L.

The cyclical variations of the mean plasma levels of FSH and LH are shown in Fig. 3.25. However, there are wide variations from one woman to another and from one day to another. In practice, therefore, single assays

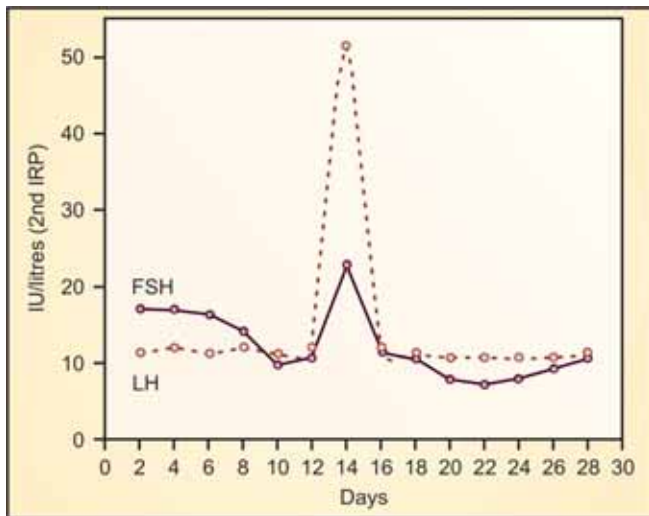


Fig. 3.25: Cyclical variations in levels of FSH and LH

are of little value in monitoring patients but may help diagnostically.

The picture is also complicated by the fact that the adrenal cortex produces oestrogens, progesterone and intermediate substances as well as androgens. Once secreted into the circulation, the fate of the hormone is related to the nature of the steroid, and not to the source. The excretion of pregnanediol and oestrogens by postmenopausal women, for example, reflects adrenal rather than ovarian activity. In the male, oestrogens are secreted by both the testes and the adrenal cortex. Hormone excretion products such as 17-ketosteroids are almost entirely indicative of adrenal cortical function.

Pregnanetriol, an excretion product of 17  $\alpha$ -hydroxyprogesterone, comes partly from the adrenal and partly from the ovary. Its urinary levels therefore show cyclical variations, and these persist in some measure in women subjected to bilateral adrenalectomy.

Adult women produce 300 mg testosterone in 24 hours, half of it coming from the adrenals and half from the ovaries. Adult men produce 7000 mg in 24 hours, 500 mg from the adrenals and 6500 mg from the testes. Testosterone contributes only 100 mg of the total urinary 17-ketosteroids in women. The fact that the testosterone contribution is so small probably explains why androgenic tumours of the ovary do not usually result in significant increases in the output of 17-ketosteroids. Plasma testosterone levels in these conditions *are* raised.

The range of total serum testosterone in women is 0.2-0.6 ng/ml compared with that of 4-8 ng/ml for men.

There is little variation in women throughout the menstrual cycle save for a slight increase during the LH rise at mid-cycle. Unlike testosterone, androstenedione levels are higher in women, 1.5-2.0 ng/ml compared to 0.8-1.2 ng/ml in men. There is a slight rise midcycle and the androstenedione levels are always slightly higher in the luteal phase. The peripheral conversion of androstenedione to oestrogens in non-pregnant women and in men is an important factor in hormonal status physiologically as well as in pathological states or conditions. There is always some variation in level from one laboratory to the other, so each laboratory must provide its reference range along with the report.

Hence, to summarise the whole event of ovarian cycle, GnRH is produced in the arcuate nucleus of the hypothalamus and secreted in a pulsatile fashion into the portal circulation, where it travels to the anterior pituitary. A change of ovarian follicular development moves from a period of gonadotropin independence to a phase of FSH dependence. As the corpus luteum of the previous cycle degenerates, luteal production of progesterone and inhibin A decreases, allowing FSH levels to rise. In response to FSH stimulus, the follicles grow and differentiate and secrete increasing amounts of oestrogen. Oestrogens stimulate growth and differentiation of the functional layer of the endometrium, which prepares for implantation. Oestrogens work with FSH in stimulating follicular development.

The two-cell two-gonadotropin theory dictates that with LH stimulation the ovarian theca cells will produce androgens that are converted by the granulosa cells into oestrogens under the stimulus of FSH. Rising oestrogen levels negatively feed back on the pituitary gland and hypothalamus and decrease the secretion of FSH. The one follicle destined to ovulate each cycle is called the dominant follicle. It has relatively more FSH receptors and produces a larger concentration of oestrogens than the follicles that will undergo atresia. It is able to grow despite falling FSH levels. Sustained high oestrogen levels cause a surge in pituitary LH secretion that triggers ovulation, progesterone production, and the shift to the secretory, or luteal, phase. Luteal function is dependent on the presence of LH. Without continued LH secretion, the corpus luteum will regress after 12 to 16 days. In the event of pregnancy, the embryo secretes hCG, which mimics the action of LH by sustaining the corpus luteum. Subsequently the corpus luteum continues to secrete progesterone and supports the secretory endometrium, allowing the pregnancy to continue to develop.



# CHAPTER 4

## Menstruation and Other Cyclical Phenomena

Endometrial Cycle	79	Cyclical Changes in the Tube	86
Correlation of Endometrial and Ovarian Cycles	82	The Cervical Cycle	86
Uterine Bleeding	83	The Vaginal Cycle	87
The Myometrial Cycle	86	Cyclical, Metabolic, Vascular and Psychological Changes	87

**Normal Menstrual Cycle:** The ovarian and the uterine endometrial changes are essential to be coordinated physiologically. The normal human menstrual cycle can be divided into two segments: the ovarian cycle and the uterine cycle. The ovarian cycle may be further divided into follicular and luteal phases, whereas the uterine cycle is divided into corresponding proliferative and secretory phases.

Menstruation is a function peculiar to women and the higher apes. It may be defined as a 'periodic and cyclical shedding of progesterational endometrium accompanied by loss of blood'. It takes place at approximately 28-day intervals between the *menarche* (onset of menstruation) and the *menopause* (cessation of menstruation).

### ENDOMETRIAL CYCLE

The cyclic histologic changes in the adult human endometrium proceed in an orderly fashion in response to cyclic hormonal production by the ovaries. Histologic cycling of the endometrium can best be viewed in two parts: the endometrial glands and the surrounding stroma. The superficial two-thirds of the endometrium is the zone that proliferates and is ultimately shed with each cycle if pregnancy does not occur. This cycling portion of the endometrium is known as the decidua functionalis and is composed of a deeply situated intermediate zone (stratum spongiosum) and a superficial compact zone (stratum compactum). The decidua basalis is the deepest region of the endometrium. It does not undergo significant monthly proliferation but, instead, is the source of endometrial regeneration after each menses.

The first 4 days are occupied with menstruation when two-thirds to four-fifths of the endometrium is shed. During the remaining 24 days the histological cycle consists basically of a proliferative and a secretory phase.

### Proliferative Phase

At the conclusion of a menstrual period the remaining endometrium is necrotic, disorganized and devoid of surface epithelium; sometimes only the basal layer

remains. The glands are macerated and broken, the stroma is infiltrated with red and white blood corpuscles (Fig. 4.1). Repair proceeds quickly and the surface is re-covered with epithelium, which grows from the glands and from the stroma, within hours of the completion of the menstrual phase. Vascular endothelial growth factor (VEGF) is a highly potent endothelial mitogen produced by the endometrium in response to oestrogen and hypoxia. It plays a role in angiogenesis and endometrial repair. By the end of 2 or 3 days the surface is intact, new vessels are growing from the stumps of the old and the glands and stroma are re-formed. At this stage, the glands are small and lined by cuboidal epithelium; they have a regular outline and tend to lie parallel to the surface (Fig. 4.2). Thereafter proliferation proceeds slowly at first but then quickly, the glands increasing in size and becoming perpendicular to the surface (Fig. 4.3). Mitoses are common in epithelial and stromal cells. The epithelial cells become columnar with their nuclei situated basally but they show no evidence of secretory activity. The stromal cells become spindle-shaped and assume a compact arrangement.

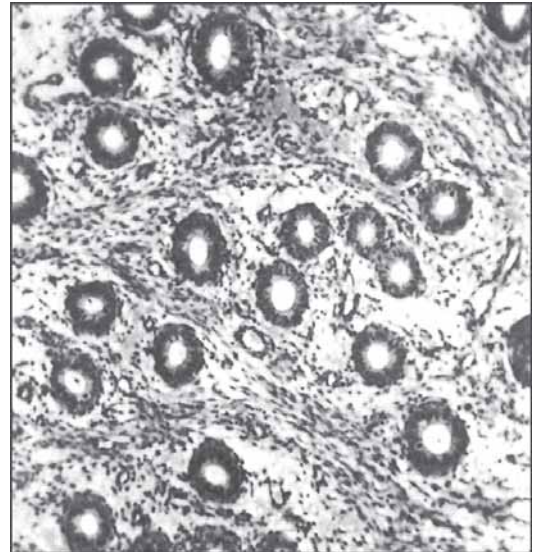
Postmenstrually the endometrium is only 1 mm thick whereas at the end of the proliferative phase (that is 10

days after the *end* of menstruation - the fourteenth day of the cycle), it measures 2-3 mm.

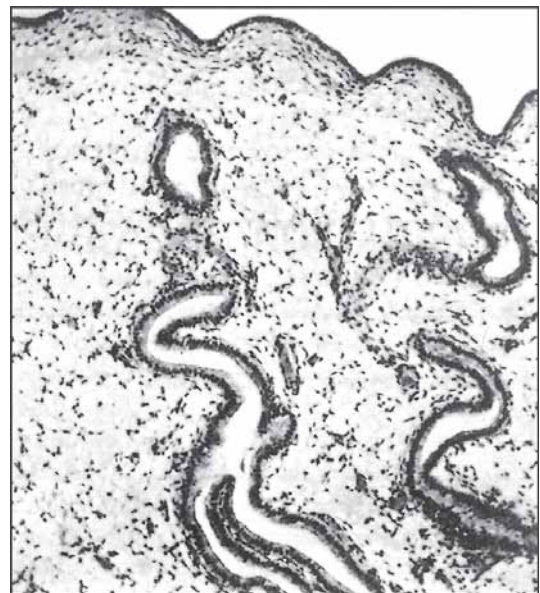
The first day of vaginal bleeding is called day 1 of the menstrual cycle. After menses, the decidua basalis is composed of primordial glands. At the beginning of the



**Fig. 4.1:** Menstrual endometrium from the second to the third day of the cycle. The basal glands, at the bottom, remain narrow and inactive, residual secretory glands occupy the midzone, and the surface layers, which are being shed, are disintegrating. (Photomicrograph x75)



**Fig. 4.2:** The early proliferative phase with small regularly shaped non-secretory glands. The glands generally appear in cross-section at this stage because they tend to lie parallel to the surface of the endometrium. (Photomicrograph x85)

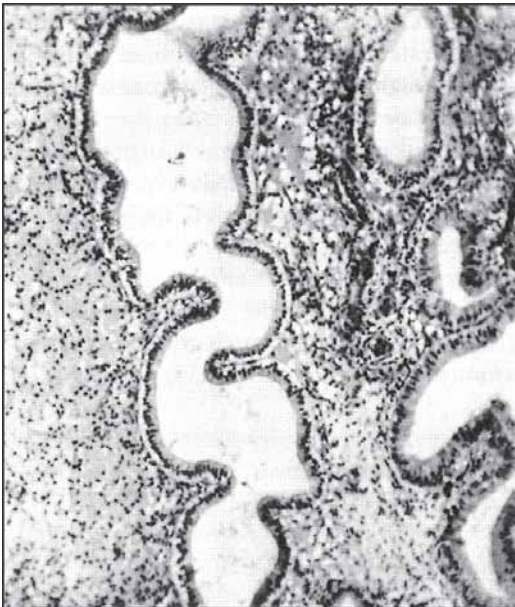


**Fig. 4.3:** The endometrium immediately after ovulation with well-developed glands some of which have cells showing early secretory activity. (Photomicrograph x85)

proliferative phase, the endometrium is relatively thin (1 to 2 mm). The predominant change seen during this time is evolution of the initially straight, narrow, and short endometrial glands into longer, tortuous structures. Histologically, these proliferating glands have multiple mitotic cells, and their organization changes from a low columnar pattern in the early proliferative period to a pseudostratified pattern before ovulation. The stroma is a dense compact layer throughout this time.

### Secretory Phase

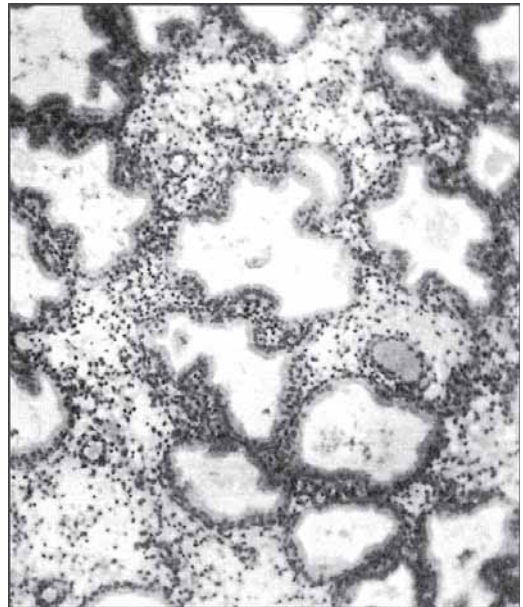
The secretory phase begins at approximately the fourteenth day of a 28-day cycle. During this phase the endometrium continues to grow to reach a thickness of 5-7 mm. During the first 3 days the epithelial cells still undergo mitosis and show pseudostratification of their nuclei. Thereafter mitosis ceases in the glandular epithelium but can be seen; in the stromal cells. The glands increase in size and become actively secretory (Fig. 4.4). The secretion collects first as a globule at the base of the cell to give rise to the appearance of subnuclear vacuolation. The globule is later seen on both sides of the nucleus but eventually collects near the lumen of the glands acinus and pushes the nucleus to the base of the cell. At the end of 5-8 days (nineteenth to



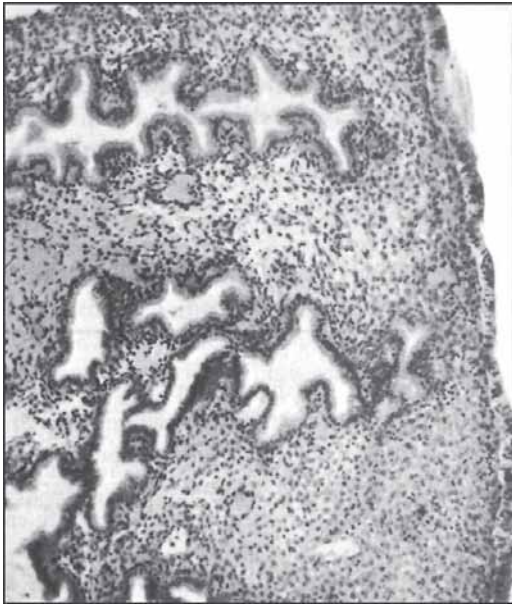
**Fig. 4.4:** The early secretory phase. The glands are larger and less regular in outline. The lining cells show globules of secretion lying basal to the nuclei, the so-called subnuclear vacuolation. (Photomicrograph x85)

the twenty-second day of the cycle) the secretion enters the gland lumen on its way to the uterine cavity, leaving the cells with their edges frayed (Fig. 4.5). This secretion, rich in glycogen, fructose and glucose, has a nutritive function for any fertilized ovum reaching the uterus. The secretory phase is also characterized by a change in the shape of the glands. As the glands and cells increase in size, and possibly also because of increased pressure from the surrounding stroma, the gland walls infold so that on cross-section they are crenated instead of round, and on longitudinal section they appear 'cork-screw' and finally 'saw-toothed' (Fig. 4.6). Meanwhile the stroma as a whole becomes more vascular and oedematous. These changes give the stroma a reticular appearance although near the surface it shows a decidual reaction which makes it compact. The latter keeps the necks of the glands narrow and straight. Decidual reaction also occurs in the vicinity of blood vessels.

Endometrial growth ceases 5 or 6 days before menstruation (twenty-second or twenty-third day), and within 1 or 2 days shrinkage is apparent. This occurs as a result of dehydration of stroma, decreased blood flow and discharge of secretion from the glands. The stroma becomes infiltrated with leucocytes and some red blood cells. Menstruation is heralded by extravasations of



**Fig. 4.5:** The late secretory phase with glands appearing crenated on cross-section. The nuclei are mainly in the bases of the epithelial cells with secretion adjacent to and within the lumina of the acini. (Photomicrograph x85)



**Fig. 4.6:** The late secretory phase with 'sawtooth' glands in longitudinal section. The stroma near the endometrial surface shows the decidual reaction typical of the premenstrual phase. (Photomicrograph x85)

serum and blood which collect in small pools near the endometrial surface. These fragment the new necrotic endometrium and break through the surface epithelium carrying pieces of it away in the bloody discharge which is the menstrual flow. Loss of tissue occurs mainly on the second and third days. During its secretory phase the endometrium shows three layers:

- A superficial compact zone consisting of stroma (with decidual reaction) surrounding the mouths of the glands.
- A middle spongy functional layer — spongy because of the numerous dilated glands and oedematous stroma.
- An inactive basal layer which shows little secretory response. This is not shed during menstruation and from it the new endometrium is formed after each period.

### CORRELATION OF ENDOMETRIAL AND OVARIAN CYCLES

By the end of, if not just before the onset of, a menstrual period, a new follicle is beginning to ripen in the ovary; endometrial proliferation therefore occurs during the

follicular phase in the ovary and is the direct result of a mounting oestrogen influence (Fig. 4.7).

Ovulation marks the change over from the proliferative to the secretory phase in the endometrium. Secretory activity and decidual reaction are manifestations of the luteal phase in the ovary and are brought about by progesterone acting in the presence of oestrogens.

The shrinkage of the endometrium premenstrually coincides with commencing failure of corpus luteum activity and is the direct result of the withdrawal of the supporting effect of oestrogens and progesterone.

These are the fundamental correlations with ovarian activity, although the timing of the histological cycle does not exactly match the rise and fall of hormone levels in the plasma (Fig. 4.7).

### Hormonal Variations

The relative pattern of ovarian, uterine, and hormonal variation along the normal menstrual cycle is seen.

At the beginning of each monthly menstrual cycle, levels of gonadal steroids are low and have been decreasing since the end of the luteal phase of the previous cycle.

With the demise of the corpus luteum, FSH levels begin to rise and a cohort of growing follicles is recruited. These follicles each secrete increasing levels of oestrogen as they grow in the follicular phase. This, in turn, is the stimulus for uterine endometrial proliferation. Rising oestrogen levels provide negative feedback on pituitary FSH secretion, which begins to reduce by the midpoint of the follicular phase. Late in the follicular phase the LH level is increased dramatically (biphasic response). At the end of the follicular phase (just prior to ovulation), FSH-induced LH receptors are present on granulosa cells and, with LH stimulation, modulate the secretion of progesterone.

With the oestrogen rising to a peak, the pituitary LH surge is triggered, which induces ovulation 24 to 36 hours later. Ovulation is the beginning of the transition to the luteal phase of the ovary or the secretory phase of the endometrium. The oestrogen level decreases through the early luteal phase from just before ovulation until the midluteal phase, when it begins to rise again as a result of corpus luteum secretion. Progesterone levels rise precipitously after ovulation and can be used as a presumptive sign that ovulation has occurred. Both oestrogen and progesterone levels remain elevated

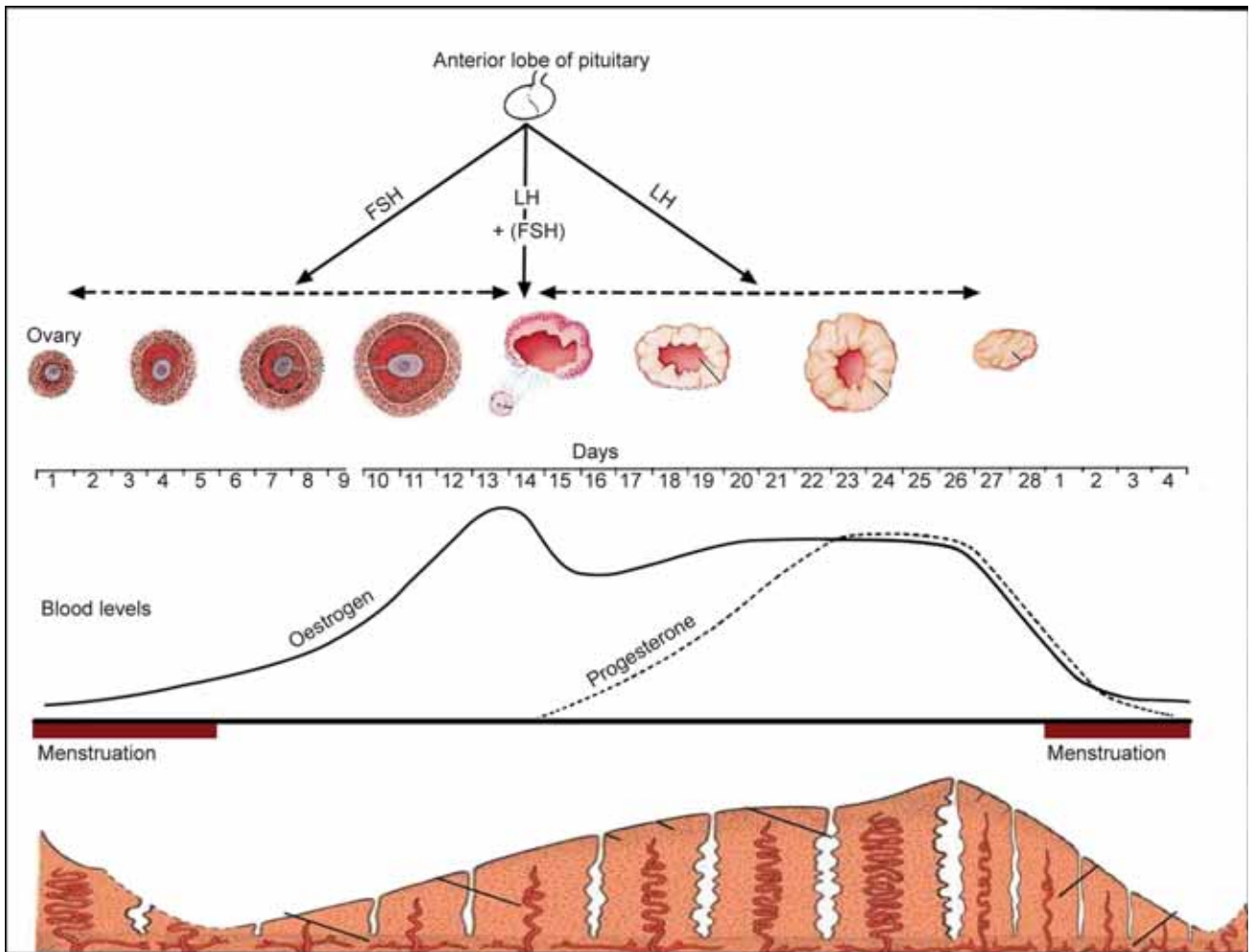


Fig. 4.7: Diagrammatic representation of the hormonal control of the ovarian and endometrial cycles

through the lifespan of the corpus luteum and then wane with its demise, thereby setting the stage for the next cycle.

### UTERINE BLEEDING

The phenomenon of uterine bleeding is best considered from the experimental aspect.

- If a woman without ovaries but possessing a normal uterus is given large doses of oestrogens for a few weeks and the administration is then suddenly discontinued, uterine haemorrhage always occurs 2-10 days later. This is termed *oestrogen withdrawal bleeding*.

- If progesterone is substituted for oestrogen in this experiment then, provided the uterus has been previously primed with oestrogens, *progesterone withdrawal bleeding* occurs within 2-5 days of suspension of medication.
- A mixture of oestrogens and progesterone has a similar effect.
- If large doses of oestrogens are given first and are then replaced by progesterone, no bleeding occurs on withholding the oestrogen. It is deferred until the progesterone is withdrawn. Progesterone is an adequate substitute for oestrogen but the converse is not true.

- If in the first type of experiment only a small dose of oestrogen is administered, no effect is seen when it is withdrawn.
- If, however, a moderate dose of oestrogen is given, then bleeding sometimes occurs intermittently, even while treatment is in progress.

Observations such as these have given rise to a concept of a *bleeding threshold* level of oestrogens in the bloodstream. The quantitative value of this level is unknown and its existence is hypothetical. Nevertheless, the idea is of practical value and is illustrated in Fig. 4.8. If the critical level is not reached, that is, if the amount of oestrogen administered is too small, no bleeding occurs. If the oestrogen level is pushed above the threshold then no bleeding takes place so long as it remains above, but once it drops to and below the threshold, haemorrhage occurs. If, however, the amount of oestrogen administered is such as to keep the blood level at or about the threshold, then bleeding may occur even while oestrogen is being given. This is generally called 'break-through' bleeding.

The above observations explain why removal of an ovary, or of the corpus luteum, at operation is often followed by uterine bleeding 2 or 3 days later.

### Menstruation

As a result of the ovarian cycle the uterus is subjected to the influence first of oestrogens and then of a combination of oestrogens and progesterone. Both are

withdrawn when the corpus luteum degenerates and menstruation occurs within a few days, that is, as soon as their levels fall to, and below, the bleeding threshold. There is some dispute as to whether the period represents oestrogen deprival haemorrhage or progesterone deprival haemorrhage, but this is an academic argument. The fundamental cause of menstruation is degeneration of the corpus luteum and this only degenerates if the ovum is not fertilised. Menstruation represents the breaking down and casting off of an endometrium prepared for a pregnancy which does not materialise, and so is sometimes described as 'the weeping of a disappointed uterus'.

With withdrawal of sex steroids, there is a profound spiral artery vascular spasm that ultimately leads to endometrial ischaemia. Simultaneously, there is a breakdown of lysosomes and a release of proteolytic enzymes, which further promote local tissue destruction. This layer of endometrium is then shed, leaving the decidua basalis as the source of subsequent endometrial growth. Prostaglandins are produced throughout the menstrual cycle and are at their highest concentration during menses. Prostaglandin  $F_{2\alpha}$  ( $PGF_{2\alpha}$ ) is a potent vasoconstrictor, causing further arteriolar vasospasm and endometrial ischaemia.  $PGF_{2\alpha}$  also produces myometrial contractions that decrease local uterine wall blood flow and may serve to physically expel sloughing endometrial tissue from the uterus.

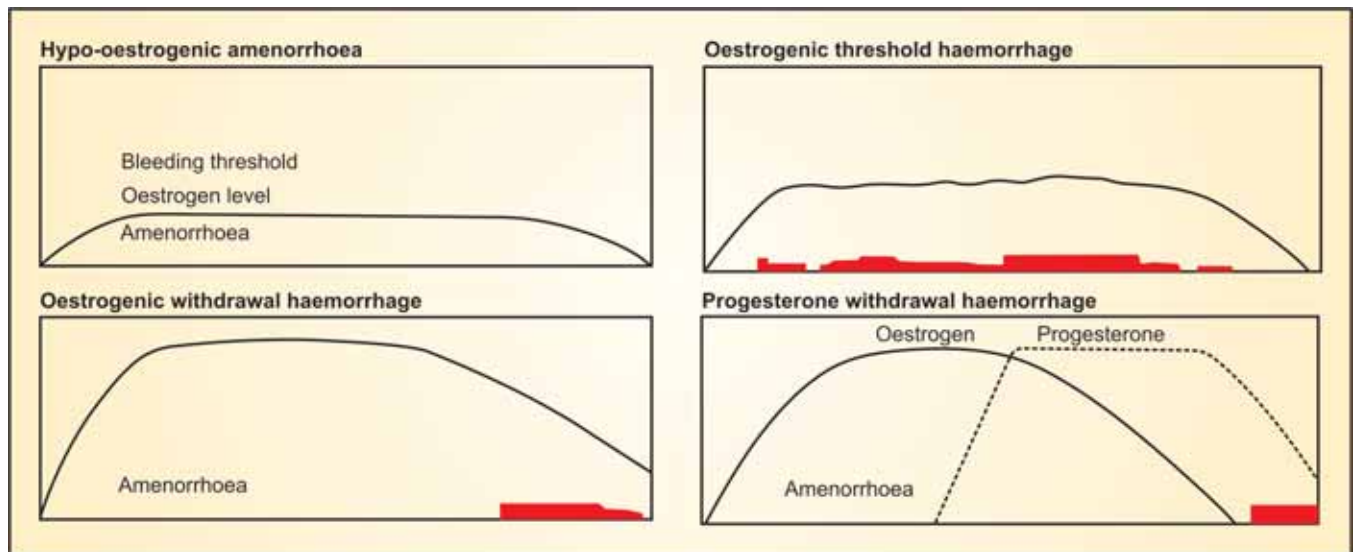


Fig. 4.8: The theoretical concept of a blood threshold level of hormones to account for different types of uterine bleeding. The black areas on the baseline indicate episodes of bleeding

### Anovular Menstruation

Degeneration of the corpus luteum was suggested as the cause of menstruation long before ovarian hormones and their effects were discovered, but the idea was always questioned because it was noted that sometimes there is no sign of a recent corpus luteum in the ovary when the abdomen is opened during a menstrual period. This observation is now explained by the phenomenon of *anovular menstruation*. Sometimes a follicle ripens but fails to rupture and is not converted to a corpus luteum. After a phase of activity the follicle degenerates, and there is thus a rise and fall in oestrogen production, the latter giving rise to oestrogen withdrawal haemorrhage. This can be completely cyclical and is outwardly indistinguishable from normal menstruation. It can, however, be recognized by histological examination of the endometrium which remains proliferative or hyperplastic but never secretory. Anovular menstruation is also always painless and unaccompanied by the usual menstrual moulins.

Anovular menstruation occurs occasionally in all women. It is probably not uncommon during the first 2 or 3 years of menstrual life and, after the age of 40 years, the incidence may rise to as high as 1 in 4 cycles. In the active reproductive period, however, not more than 1 in 10 to 1 in 50 regular cycles is anovular. For practical purposes, in mature women regular menstruation means regular ovulation.

### The Mechanism of Bleeding from the Endometrium

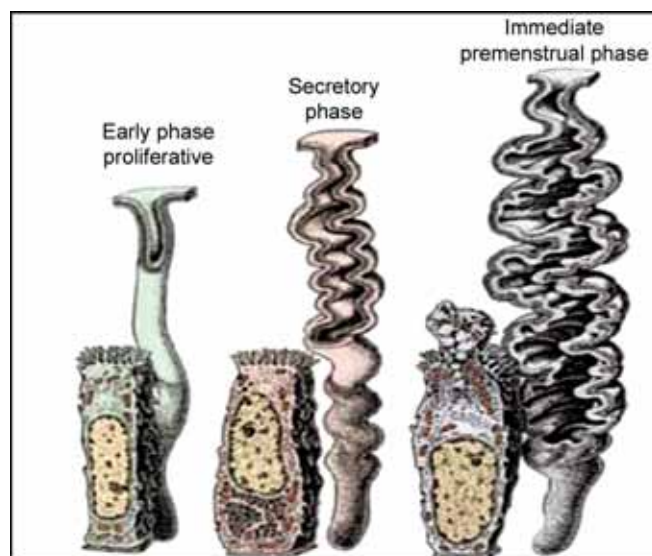
The main arteries supplying the endometrium lie where the muscle mucosal elements of the uterus intermingle and they run parallel to the endometrium. Arterioles from these basal arteries come off at right angles and are directed towards the uterine cavity (Fig. 4.9). In the first part of their course they are straight but more superficially they are coiled. The coiling allows lengthening and shortening of the vessels and reduces intravascular pressure. These arterioles provide for the middle and superficial layers of the endometrium, each supplying a limited area and having very little communication with its fellows. Capillaries beneath the surface of the endometrium are drained by veins which run parallel to the arteries. Arteriovenous connections are also described.

When the hormonal support of the secretory endometrium is withdrawn consequent to the degeneration of the corpus luteum, the endometrium shrinks

and the vessels have to shorten by increasing and tightening their coils. This in turn retards their circulation and results in ischaemic necrosis of the area of endometrium for which they are responsible. Some of the capillary stasis and other changes such as leucocytic infiltration of the stroma are caused by haemodynamic factors which are not understood, but some authorities believe that there is an arterio-venous shunt. Increased premenstrual permeability of the capillary reflects an oestrogen influence.

The breakdown does not occur simultaneously in all parts of the endometrium and each microscopic area bleeds intermittently for short periods, but the endometrium oozes from one part or another for a total of 3-5 days. The bleeding itself occurs from broken arteries, veins and capillaries, and from haematomas which form in the stroma in the immediate premenstrual phase.

Having entered the uterine cavity the blood coagulates but the clot is mostly dissolved by thrombolytins released from the endometrium. Proactivator of plasminogen is present in the endometrium at all times and, with the approach of menstruation, is converted to activator, probably as a result of anoxia or breakdown of tissue. Fibrin degradation products therefore circulate



**Fig. 4.9:** Diagrammatic representation of the endometrial glands and arterioles throughout the menstrual cycle. The veins are omitted for simplicity. The endometrium deep to the dotted line is relatively insensitive to hormones and is not shed during menstruation; its viability is maintained by special branches from the straight portions of the arterioles

in increased amounts during menstruation, and especially high levels are found in the uterine veins.

As a result of fibrinolysis the effluent from the uterus consists of altered blood, rich in calcium but deficient in prothrombin and fibrinogen. The expulsion of this, together with fragments of endometrium, is brought about by uterine contractions.

The occurrence of spasm in the straight stems of the endometrial arterioles is very important. This is seen about the time that bleeding commences and maybe the result of the action of the prostaglandin  $F_{2\alpha}$  released from the degenerating surface of the endometrium. It was at one time thought that the spasm causes the ischaemic necrosis but it is now believed to be a later phenomenon whose purpose is to limit the amount of bleeding from the arteriole. Indeed it is alleged that but for this protective spasm a woman might bleed to death as a result of menstruation. The amount of loss may also be controlled by muscular compression of the larger arteries as they pass through the myometrium. It is also determined by the area of the endometrial bleeding surface and by the intensity of the previous hormone stimulus. Other vasoconstrictors, e.g. endothelium and platelet-activating factor (PAF) have been identified but their exact role is unclear.

The mechanism of bleeding is the same no matter whether menstruation is ovular or anovular in type, although in the latter case there is rather less tissue destruction.

When the endometrium breaks down, the basal layers are not involved because they are supplied by blood vessels which come off the main arteriole proximal to the part affected by coiling and spasm (Fig. 4.9). Postmenstrually, new arterioles grow from the old stumps just as the endometrium grows from its basal layer. They do so as a result of the oestrogen stimulus from the next ripening graafian follicle.

## THE MYOMETRIAL CYCLE

The activity of uterine muscle changes with the menstrual cycle. During the early follicular phase the contractions are small and frequent and the response to oxytocics is limited. Activity increases with the oestrogen stimulus of approaching ovulation. In the premenstrual and menstrual phases the contractions are less frequent but are of greater amplitude, and muscle sensitivity is increased. The strongest contractions occur during

menstruation and may, to some extent, be stimulated by *prostaglandins* released from the endometrium.

## CYCLICAL CHANGES IN THE TUBE

The muscle of the fallopian tube behaves like the myometrium in that it shows increased movement about the time of ovulation. This is an oestrogen effect as is the increased ciliary activity at that time. These changes are timed to propel the ovum towards the uterus.

The follicular phase is marked by slight proliferation, with minimal mitotic activity of the mucosa, and this continues up to the premenstrual phase when it regresses. During menstruation there is further shrinkage and slight shedding of the surface epithelium; occasionally the endosalpinx may even menstruate.

The secretory activity of the tube is also cyclical, being highest just before ovulation and in response to oestrogen. Progesterone may also play a part in this but the consensus of opinion is that this hormone reduces the amount of the secretion.

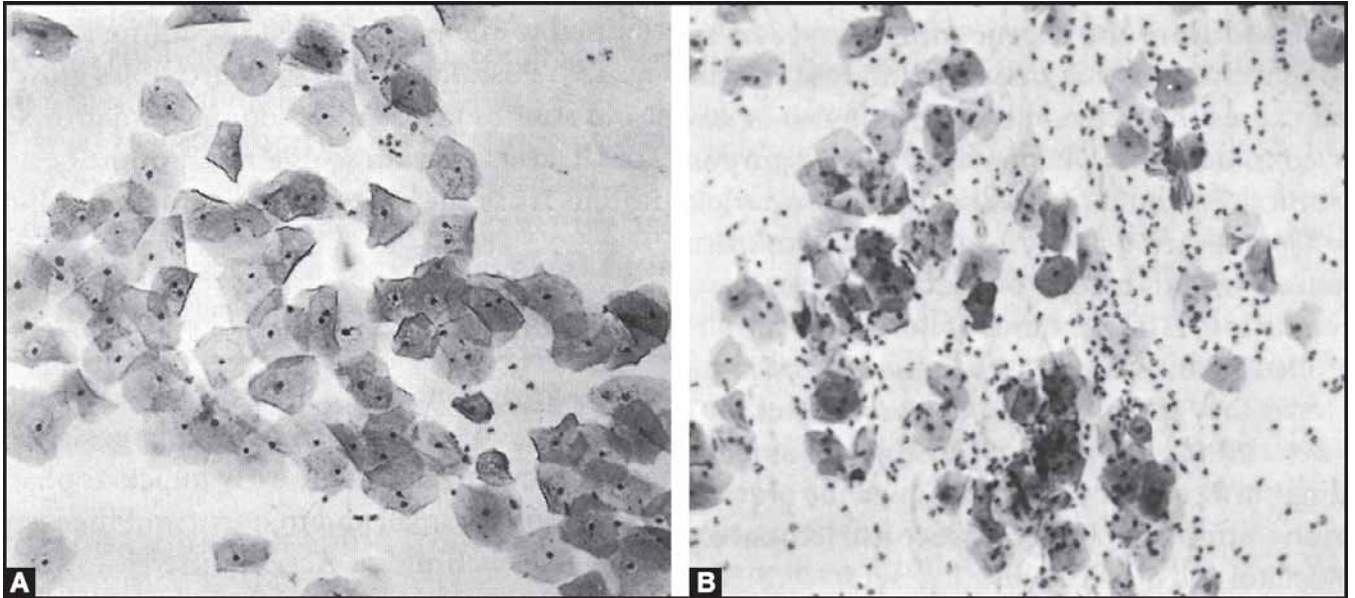
## THE CERVICAL CYCLE

Progesterone raises the tone of the muscles of the isthmus and internal os so the cervical 'sphincter' is tighter and more competent during the luteal than during the follicular phase.

The glandular elements of the cervix proliferate during the follicular phase and the epithelial cells become taller. Under the influence of oestrogens the glands also actively secrete a mucus which will stretch into threads measuring more than 6.5 cm, and even 10-15 cm, at the time of ovulation. This property of 'spinnbarkeit' is the basis of the *thread test* for oestrogen in circulation. During the follicular phase the cervical mucus absorbs water and salts and, when allowed to dry, deposits crystals of sodium chloride and potassium chloride in a characteristic pattern which suggests the fronds of a fern (Fig. 5.2). At the time of ovulation the secretion is so profuse that it may be noticeable as a vaginal discharge - the 'ovulation cascade'. Its special character at this time makes for its easy penetration by spermatozoa. This property is related to its low content of protein.

During the luteal phase the cervical glands become more branched and their secretion changes its physical and chemical properties. The mucus becomes more viscous and forms a more secure cervical plug. It loses its ability to stretch without breaking and resists





**Figs 4.10A and B:** Normal vaginal smears, (A) The oestrogenic smear obtained during the follicular phase of the cycle shows large squames with pyknotic nuclei, (B) The postovulatory smear with similar squames, many of which now have rolled edges, and with large numbers of leucocytes

penetration by spermatozoa. These changes are brought about by progesterone and are related to an increase in the amount of protein in the mucus and to the presence of phospholipids.

Progesterone also reduces the electrolyte content of the mucus, so by the twenty-second day of the cycle its property of ferning or arborization on drying is lost.

During menstruation the cervical glands collapse and may show slight desquamation with loss of blood.

### THE VAGINAL CYCLE

Cyclical histological changes occur in the vaginal epithelium but they are not clearly defined in tissue sections. They are better seen in smears of desquamated cells (Figs 4.10A and B). The unstimulated vagina shows relatively small basal type cells with healthy nuclei. These and intermediate basophil forms are also seen in vaginal smears taken in the early follicular phase. The

fully oestrogenic smear, evident during the late follicular phase, contains a preponderance of large cornified epithelial cells with pyknotic nuclei. These stain pink with eosin. During the luteal phase the smear shows evidence of increased desquamation, many of the cells having rolled edges, and is characterized by the reappearance of clumps of intermediate cells and the presence of leucocytes.

The *maturation index*, which is the percentage of superficial, intermediate and parabasal cells in a vaginal smear is used as a measure of the levels of hormones in circulation. It is a useful guide but is not so precise as assaying the hormones in blood.

### CYCLICAL, METABOLIC, VASCULAR AND PSYCHOLOGICAL CHANGES

These are discussed in detail in Chapter 5 (Section on Menstruation) and Chapter 40.

# CHAPTER 5

## Clinical Aspects of Menstruation and Ovulation

Menstruation	88
The Menopause and the Climacteric	91
Ovulation	100

### MENSTRUATION

#### General Description

As mentioned earlier, the menarche is quite a late feature of puberty. The first period may be short or long; thereafter the cycle is often irregular, periods occurring sometimes every few months, sometimes too frequently. A more or less regular rhythm is usually established within 2-3 years.

During the active reproductive era menstruation occurs at approximately 28-day intervals. Each woman tends to have her own rhythm although it may change after marriage or childbearing. Any regular cycle of 3-5 weeks is arbitrarily accepted as normal, but some women menstruate less frequently than this and still have good health and fertility. Those women who allege that their menstrual function is always completely regular delude themselves if not others: if records are kept all can be shown to have occasional cycles which vary by at least 2 days less or more than 28 days.

In the same way there are wide variations in the duration and amount of blood loss. The duration is most often from 3 to 5 days but anything between 2 and 7 days is accepted as normal; even these limits need to be extended in individual cases.

The menstrual flow is sometimes called *the menses* or *catamenia*. It begins as a pink discharge consisting of cervical mucus and blood, and is rich in leucocytes. It is heavier on the second and third days when it is dark red in colour and consists of blood, endometrial and cervical secretion, endometrial debris and bacteria. The discharge has a characteristic odour caused partly by bacterial action and degeneration, and partly by the accompanying secretions of sebaceous and apocrine glands on the vulva. The total loss of blood is difficult to estimate but is said normally to vary from 5 to 60 or 80 ml with an average of 35-45 ml. This is equivalent to an average daily loss of 0.6-0.7 mg iron throughout each month.

Normally, high fibrinolytic activity makes the menstrual efflux mainly fluid; small clots are noticed occasionally by 50 per cent of women. The passage of large clots usually means that the bleeding is so abnormally heavy as to defeat the process of fibrinolysis.

It is convenient to describe the menstrual function of any woman in terms of a fraction, the numerator referring to the duration of the flow and the denominator to the length of the cycle from the beginning of one period to the beginning of the next. A normal cycle may therefore be represented by 4/28.

### General Disturbances Associated with Menstruation

Menstruation is frequently accompanied by minor physical and nervous disturbances. It is estimated that only 20 per cent of women are completely free from discomfort or upset and that only 3 per cent of young nullipara do not experience premenstrual molimina of some kind. The degree of disturbance, however, depends to a large extent on the individual's outlook towards this physiological process, and on her determination not to allow it to interfere with her normal life. Highly strung emotional women exaggerate the significance of menstruation while well-balanced individuals disregard it. Fifty per cent of women less than 30 years of age experience an ache or pain in the lower abdomen, pelvis or back before or during menstruation.

General manifestations mainly occur pre-menstrually and include a feeling of lethargy and tiredness, malaise, depression, excitability and irritability, headache, fullness and tenderness of the breasts, inability to concentrate and impairment of efficiency in both mental and physical activities. It is of interest to note that the majority of accidental and suicidal deaths among women occur during the luteal phase of the cycle. Many women have a sensation of an impending period which includes a feeling of weight in the pelvis, possibly related to congestion of the pelvic viscera. This is followed by a sensation of relief when the period is well established. Changes in bowel function occur in 50 per cent of women, the most common being a tendency to constipation (with abdominal distension) premenstrually and more frequent motions during menstruation. This is a result of a disturbance in the autonomic nervous system as may also be premenstrual frequency of micturition. Nausea and vomiting may occur but these are mostly associated with dysmenorrhoea. Skin changes include shadows under the eyes, and the occurrence of rashes or a few acne spots on the face, back or chest. The first are probably due to MSH, the second to progesterone. The blood viscosity is highest in the third week of the

cycle and lowest at the time of menstruation when bruising and epistaxis may occur. All circulatory errors in the lower limbs, such as varicose veins and inherent defects, are more obvious premenstrually.

Enlargement of the thyroid gland may be noticeable a few days before menstruation. At this time, too, there may be slight rises in the levels of blood sugar and blood pressure, and some increase in pulse and basal metabolic rates. There is a tendency to retention of sodium and water in the tissues during the last week of the cycle. This is thought to be an effect of the high oestrogen level in the blood but peak plasma levels of aldosterone and renin at the time may have a bearing. It accounts for some of the general disturbances described above and for an increase in weight. One-third of normal women temporarily gain 1.4 kg or more in weight premenstrually. This feature is more common in women aged 25 and above, younger women generally notice little change.

### Management of Normal Menstruation

Menstruation is still a subject for taboo, superstition and folklore, and the handing on of these to young girls can be responsible for abnormal reactions to menstruation. One of the fallacies, which carries the support of religious practices, is that the menstruating woman is unclean. This idea alone is enough to instill feelings of shame, embarrassment and resentment. Again, it is commonly believed that girls are in low physical state during menstruation, that they are especially vulnerable to all manner of ills, and that dire results will follow bathing or even washing their hair at this time. These beliefs are to be resisted and corrected. The menstrual function should be explained to girls truthfully, if simply, and they should be made to realise that it is not a method for excreting something which is noxious but rather a manifestation of womanhood. There is no need for them to stop playing games or for not undertaking anything to which they are accustomed. Indeed they should be encouraged to live their usual life.

The menstrual discharge is contained either by means of a sanitary pad (diaper) applied to the vulva or by an absorbent tampon placed within the vagina. In either case regular and frequent changes are necessary if offensiveness and chafing are to be avoided.

Intravaginal tampons are comfortable, unobtrusive and convenient. It is said that they shorten the apparent duration of a period by 24 hours because the last day of

the flow ordinarily consists only of drainage from the vagina. Their disadvantages are:

- They cannot be used unless the hymen is torn or stretched.
- One may be forgotten and left in the vagina for several weeks when it can cause pelvic infection. This should not happen to an intelligent woman but it does, and a stinking tampon has sometimes to be removed in an outpatient clinic.
- They are inefficient if the flow is heavy.
- In general, the proper use of tampons does not lead to vaginitis, cervicitis, erosion or lowered fertility. In 1978, the *toxic shock syndrome* (TSS) was first described in children with acute infection due to *Staphylococcus aureus*. Subsequently, the syndrome was described in the USA in association with menstruation and the use of tampons. No particular type of tampon has been implicated. One can reassure women that the risk of contracting TSS is very low and can be reduced by using tampons for part of the period only (using pads at night), and using only the standard size which are changed more frequently.

One possible contraindication to the use of tampons is the presence of an intrauterine contraceptive device which has a tail lying in the cervical canal or vagina. This may become entangled with the result that the device is displaced on removal of the tampon.

In some countries, young girls are taught to douche the vagina at the end of each menstrual period. This again is a relic of the old idea of uncleanliness. Vaginal douching as a hygienic measure at the end of a period, or at any other time, is unnecessary and is potentially harmful in that it washes away the natural protective discharges. The vagina can take care of itself and it is remarkable how it cleans itself of all menstrual debris in the course of a few hours. Girls and women should also be warned against the use of vulvar and vaginal deodorant powders and sprays. They are unnecessary and very liable to produce local reactions. Talc-containing deodorants have been implicated as an aetiological factor for ovarian cancer.

Although many married couples shun coitus during menstruation, its practice at such time is probably more frequent than is generally realised. The menstrual phase is part of the 'safe period' and some women have a strong sexual desire at that time. Many women, however, react to menstruation by embarrassment and increased modesty (the taboo of uncleanliness), and resist coitus

at that time. The Jewish law forbids coitus during the period (or for 5 days, whichever is the shorter) and for 7 days afterwards, making a total of 12 days in any one cycle. It is remarkable that this old code provided for abstinence during what is now recognised as a safe period, and allowed resumption of marital relations at the optimum time for conception.

Medical arguments against the practice of coitus during menstruation are that sexual excitement may cause uterine congestion and increase the menstrual flow, that the more vascular and friable vaginal walls maybe injured, and that the associated orgasm may encourage retrograde menstruation and the development of endometriosis. These are theoretical considerations of little practical significance. If there is chronic or latent infection in the genital tract of either the male or the female, there is danger of causing salpingitis if coitus is practised during menstruation, but in a healthy couple there is no sound medical reason for advising against it. The only real objection is the obvious aesthetic one.

### The Artificial Deferment or Advancement of Menstruation

Some women, anticipating that a menstrual period will clash with an important business or social engagement, ask to have its onset changed. A dysmenorrhoeic student may fear that her period will commence on the day of a professional examination; the athlete is worried lest menstruation mar her performance; the prospective bride is embarrassed at the thought that her marriage is planned to coincide with the menses. In nearly all such cases it is best to advise that no treatment be given because a clash is not inevitable in that the date of the next menstrual period can never be calculated accurately, and the anticipation of the important occasion may itself make the period early or late; also the hormone therapy necessary may be more upsetting than the period and may result in break through bleeding.

If the circumstances appear to justify taking action, it is generally better to postpone than to advance the flow. This can be done by maintaining the ovarian hormone levels in the blood artificially at the time when their natural fall would lead to menstruation. For this purpose, oral therapy with one of the oestrogen-progestogen contraceptive preparations (one or two pills daily), or with a progestogen such as norethisterone, 5 mg tds, is usually adequate. Treatment is commenced 3-6 days

before the expected onset of the period and is continued until the crisis is over. The flow is to be expected 2 or 3 days after the treatment is suspended.

To bring on menstruation prematurely it is necessary to start treatment early in the cycle and to suppress ovulation. This can be done by giving an oestrogen-progestogen oral contraceptive once daily. Treatment is commenced on the fifth day of the cycle and continued for 14 days. When it is suspended, menstruation (anovular) is likely to begin within 2 or 3 days, that is approximately one week before it would otherwise have occurred.

## THE MENOPAUSE AND THE CLIMACTERIC

### Definition and Age

**Definition:** Menopause is defined as the permanent cessation of menses for 1 year and is physiologically correlated with the decline in oestrogen secretion resulting from the loss of follicular function.

The terms 'menopause' and 'climacteric' are often used synonymously but they refer to essentially different conditions. The *climacteric* is the counterpart of puberty and is a transitional phase lasting from 1 to 5 years during which the genital organs involute in response to the cessation of gonadal activity. The *menopause* is the counterpart of the menarche and refers only to cessation of menstruation; it is merely one manifestation of the climacteric ('change of life') and precedes complete cessation of ovarian function by several months or years. The interval between the two may in part be explained by the secretion of oestrogen by the adrenal cortex or by the ovarian stroma. Hyperplasia of the stroma of the ovarian cortex is described as a frequent finding in women aged 40-60 years, and is a postulated source of oestrogen - even after the menopause. The menopause and climacteric are peculiar to the human race; in lower animals, ovulation and fertility continue into old age. Ten per cent of men are also said to experience a climacteric (the *andropause*) but at a rather later age than women.

The age of the menopause does *not* depend on the age of menarche, the type of menstrual cycle, the number of pregnancies which a woman has had, marriage, climate or environment. *In the absence of general or pelvic disease*, and with the possible exception of economic and social status, the only known factors governing it are

familial and racial. The menopause usually occurs between the ages of 45 and 52 years, but it is not uncommon to meet women of 53 or 54 years who are still menstruating regularly. The average age, which used to be 47 years in Britain and the USA, is now said to be 51 years. The mean has risen by 5 years in the last century, a change which probably reflects a general improvement in health and vigour of the community and a determination of women to stay young. In India, it is still estimated at 48 years.

Menstrual function may cease suddenly without warning, but the menopause is most often heralded by a gradual decrease in the amount and frequency of blood loss during several months or years. Excessive and prolonged bleeding is never a feature of the *normal* climacteric or approaching menopause. The menstrual cycle ceases because the ovaries cease to react to the stimulus of the anterior pituitary gland. This is related to the disappearance of all the primary oocytes which is an ageing effect. The pituitary continues to pour out gonadotrophins and indeed, being released from an inhibitive, influence produces them in very large amounts. Traditionally, menopause has been diagnosed retrospectively based on the lack of menstrual periods. With the advent of modern laboratory testing, menopause may now be more precisely defined as amenorrhoea, with signs of hypoestrogenaemia, and an elevated serum follicle-stimulating hormone (FSH) level of greater than 40 IU/L. Various symptoms like hot flashes also points towards diagnosing menopause. Hot flashes and other acute symptoms associated with the perimenopausal period often become more intense near menopause when the levels of circulating oestrogen suddenly drop. These symptoms are especially intense in patients who experience premature ovarian failure or surgical menopause because of the peripheral conversion of both ovarian and adrenal androgens to oestrogen, the loss of ovarian function does not result in an absolute oestrogen deficiency. As a result, some women are less affected by oestrogen deficiency than others.

### Physical Changes

Although in 50 per cent of women the effect is temporarily delayed by a trickle of oestrogen from the adrenal, the whole genital tract reacts to waning ovarian function by atrophy and inactivity. The breasts shrivel and become flat except in obese women in whom they

may remain large and pendulous; this is because atrophy affects glandular tissue only. The anterior pituitary responds by histological as well as functional changes, and the workings of the thyroid and adrenal are also altered. Initially thyroxine metabolism slows down and there is a compensatory decrease in thyroxine secretion. Later, conversion of T4 to T3 decreases and TSH levels increase (latent hypothyroidism). The incidence of hypothyroidism increases with age and is commoner in women than in men. In a small proportion of women overt hypothyroidism results.

As a result of the hormonal changes, the woman becomes coarser in build and appearance, and develops features suggestive of a mild degree of acromegaly. The shoulders become fat, the waistline is lost, and there may be a slight growth of hair on the face. Axillary and public hair are not shed because these depend on the adrenal rather than the ovary. Body hair becomes sparse only later in life and this is part of a senile change affecting all organs.

Increase in weight is common at the climacteric but is not inevitable as is generally believed. When it does occur it is often related to an increased appetite or eating in the face of emotional stress, as much as to an alteration in metabolism which lowers the nutritional requirements. The plasma and urinary levels of calcium and potassium tend to rise; this may have either a cause or effect relationship to osteoporosis.

### Psychological Changes

These vary considerably and depend largely on the make-up of an individual and on her previous outlook on the menopause and its significance. This in turn is influenced by whether the woman is single or married, and whether she is childless and grand-childless or surrounded by a happy family. In the well-adjusted and well-informed woman psychological changes are few and insignificant, amounting to no more than a period of slight emotional instability. This is also true in the East where age brings with it an increase in social esteem.

Unfortunately, the menopause and the climacteric, like other aspects of the menstrual function, are subjects about which there are many fallacious ideas. For this reason many women approach the menopause with a dread which may have been with them for the previous 5-10 years. They fear insanity, loss of femininity, obesity and loss of their husband's affection. Some associate the

menopause with the development of cancer. For many it heralds the beginning of old age.

A fundamental reason for emotional upset is that the menopause represents the end of the reproductive era and this means something to all women, even those who have as many children as they want. It inevitably means more to the barren and unmarried woman who had previously lived in hope. Married women are sometimes worried by the idea that the menopause means the end of sexual desire and physical love. In fact, and unless the woman wills it otherwise, libido usually remains unchanged and marital relations continue after the menopause. It is reckoned that 75 per cent of couples in Britain aged 60 years still practise coitus regularly. Sex life wanes only gradually as part of the ageing process in both partners. It is influenced more by culture and individual attitudes than by declining hormones. Sex urge in the woman may even be temporarily increased by the menopause, especially if it has previously been inhibited by fear of pregnancy.

One of the difficulties is that middle age is often a period of stress in the home. Children are at an age when they can cause parents much anxiety (often needless) and expense. Household duties are heavy and the mother is no longer so physically fit to cope with them. Often she is untrained for anything other than marriage and it has become clear that her husband is never going to achieve the success at one time expected. It is no wonder, therefore, that many women in their forties develop all manner of minor complaints and neuroses. These are not always easy to treat successfully and it is tempting to both the patient and her doctor to attribute them to the menopause. This gives the menopause a bad name and is, in the long run, the main reason why so many women approach it with fear.

### Climacteric (menopausal) Symptoms

While the metabolic processes and the functions of other glands are becoming adapted to the cessation of ovarian function, a woman often experiences symptoms which are generally called 'menopausal' but they are strictly 'climacteric'. For this reason they arise some months or years *after* the cessation of menstruation and *never occur while menstruation remains regular*. If there is enough oestrogen in circulation to produce a period, there is enough to prevent climacteric symptoms. The exception to this rule is the hot flush which is brought about by the

relatively sudden change in hormone levels and is not seen in women who are chronically hypo-oestrogenic, e.g. Turner syndrome, or those subjected to bilateral oophorectomy in childhood. If this is recognised then many women in their forties will be spared the misery of being told that any discomforts they report are caused by the change of life.

The immediate cause of climacteric symptoms is generally ascribed to oestrogen deficiency and the compensatory gonadotrophic overactivity of the hypothalamus and pituitary. True climacteric symptoms certainly reflect an endocrine readjustment in which the adeno-hypophysis plays a part because they are not experienced by women with primary pituitary failure (for example, Sheehan's syndrome), and their incidence is related to the level of gonadotrophins. But the mechanism must be complex because women who have never been exposed to ovarian hormones do not suffer from hot flushes even though their production of gonadotrophins is high.

Seventy-five per cent of women experience some disturbance at the time of the climacteric but only 25 per cent require to seek medical advice and not more than 5-10 per cent need more than reassurance. The incidence, type and severity of climacteric symptoms depend on the physical, mental, emotional and social condition of the woman. 'Menopausal' symptoms fall into several groups and can be broadly classified as given below.

### Neurotic and Psychotic

These include depression, memory loss, nervousness, irritability and inability to concentrate. Headaches are also common and there may be insomnia, paraesthesiae of the hands and feet, giddiness and head noises. These problems are seen frequently early after menopause, but their causal relationship with oestrogen is unclear. Oestrogen therapy may help to improve headaches and insomnia in some of these women.

### Gastrointestinal

Appetite may be increased or decreased and there may be various forms of dyspepsia, especially intestinal distension and constipation associated with colonic spasm.

### Cardiovascular

Palpitations and precordial pains are not uncommon. The most important symptom, however, and the one

which is used as an index of the severity of climacteric upsets, is *hot flushes*. This is a manifestation of a vasomotor instability which results in a tendency to flush or blush, especially around the face and neck. The flushes are brought on particularly by excitement, nervousness and a hot atmosphere, and they possibly correspond to the blushes of the adolescent. They vary in number from one or two in 24 hours to one every 15-30 minutes, and are often associated with profuse sweating. They occur by night as well as by day and sleep is disturbed by *night sweats* which leave the woman bathed in perspiration. Vasodilatation is followed by vasoconstriction, so after a flush comes a *cold shiver*. Synchronous with the onset of each flush is the release of a pulse of LH. Each hot flush averages 2.7 minutes but is commonly 1 to 5 minutes in duration.

The incidence of coronary artery disease and myocardial infarction in women, which is about a fourth of that in men in the premenopausal years, rapidly increases in the postmenopausal years to approximately the same as in men. This has been attributed partly to alterations in lipid profile. The high density lipoprotein (HDL) cholesterol level is about 10 mg/dl higher in both pre- and post-menopausal women than in men. However, total and low density lipoprotein (LDL) cholesterol levels which are lower in premenopausal women rise rapidly after the menopause. Oestrogen may protect women through other mechanisms also which include the following: direct inotropic effect on the heart; favourable impact on fibrinolysis; augmentation of vasodilating and antiplatelet aggregation factors, e.g. nitric oxide and prostacyclins; inhibition of smooth muscle growth which prevents intimal thickening; reduction of angiotensin-converting enzyme and renin levels; reduction of insulin and homocysteine levels.

### Osteoporosis

Senile osteoporosis occurs in both sexes, but women lose more bone than men after the menopause. Osteoporotic fractures constitute a major public health problem. The main bone loss is in the vertebrae and the hip. Fifty per cent of all fractures are vertebral. They may be asymptomatic, manifesting as a loss of height up to 2.5 cm or the dorsal kyphosis of the dowager's hump. Hip fractures at the femur neck lead to increased mortality and morbidity. Approximately 10 per cent of these women die within 6 months due to surgical complications while a large number are unable to resume

normal activities. The third most common site of fracture is at the distal end of the radius. Osteoporosis of the jawbone leads to tooth loss. The critical blood level of oestradiol required to maintain bone mass is 40-50 pg/ml (150-180 pmol/L).

### Genital and Sexual

Libido is not usually materially reduced but, as the years go by, atrophy and dryness of the vagina can cause dyspareunia. Pruritus vulvae is *never* a symptom or result of the climacteric.

### Urinary

Urethritis with dysuria, frequency and urgency occur because of thinning of the mucosa of the urethra and bladder. The patients present with recurrent urinary tract infections and stress incontinence.

### Others

All manner of other symptoms and signs are ascribed to the menopause. They include painful and tender breasts (fibrocystic disease), joint pains (menopausal arthropathy), fibrositis and myositis, pigmentation of the skin, the development of warts and naevi, keratoconjunctivitis sicca, menopausal hypertension and onset of Alzheimer's disease. Some of these conditions are age related and some are directly related to waning ovarian function. Hypertension and arthritis, for example, are not prevented or reversed by oestrogens. Alzheimer's disease, on the other hand, has been shown to be linked with declining oestrogen levels, and will hopefully be prevented by oestrogen replacement therapy. Osteoporosis associated with arthritis may be benefited by oestrogen therapy. Oestrogen deficiency is currently being linked to cancer of the colon, cataracts and retinal dysfunction. Treatment of keratoconjunctivitis sicca with oestradiol drops has shown a better response in the postmenopausal woman than artificial tear drops alone.

### The Management of the Menopause and of Climacteric Symptoms

Whether to recommend hormone replacement therapy (HRT) to postmenopausal patients is a challenge facing many physicians. Equally difficult is an individual woman's decision to take or not to take HRT.

Controversies started with the publication of some of the literature. The findings of the Women's Health

Initiative (WHI) study, a prospective, randomised trial of more than 16,000 healthy, post-menopausal women, published in July 2002, have thrown the use of HRT into question in both the medical and lay communities. Publications mention about the increased risk of invasive breast cancer among women receiving the combined therapy, as well as heart attacks, stroke and clotting. These risks were not offset by the benefits: a decrease in colon cancer, and hip fractures.

However, the average age of the women in the WHI was 63.2 years, and does not reflect normal clinical practice where replacement is used mainly for symptoms including hot flashes, in women 10 to 30 years younger. Women in the WHI also had an average BMI of 28, one-third had hypertension, and one-half had a history of smoking. Thus, at the present time, the relative risk to benefit of using HRT in younger, healthier women is largely unknown, and physicians cannot make all clinical decisions by the WHI study, as it appears to apply specifically to the population studied. Hormone replacement is still an important therapeutic modality for women for symptoms and quality of life issues which deserves further study, and should be considered by physicians with their patients on an individual basis.

### General

It is first necessary to exclude organic disease as a basis for whatever the complaints may be. Thereafter it is essential to ensure that a woman understands that the menopause represents a change of life and not an end of life, and that, unless she allows it to do so, it will not result in her suddenly becoming aged and unattractive.

'Middle age spread' can be prevented by reasonable restriction of diet and appropriate exercise. It is important for the woman to recognise the benefits of exercise and include a regular programme in her schedule for at least half an hour every day. Walking is the safest and easiest, but does not have an impact on spinal bone density. Running, aerobics, weight lifting and climbing stairs are useful, but should be done in consultation with the physician. Women who exercise 3 or more times a week have fewer menopausal symptoms, i.e. vasomotor symptoms, negative moods, loss of libido and memory loss. Relaxation exercises help to decrease hot flashes.

The diet should contain 1000-1500 mg of calcium. Milk, beans, broccoli, spinach and fish are good dietary sources of calcium but a supplement may be required. Phytoestrogens are present in soyabeans, cereals and



legumes and their adequate intake helps to prevent or relieve menopausal symptoms.

Cigarette smoking, high intake of salt and consumption of alcohol, coffee and aerated drinks should be avoided as these are associated with a higher incidence of osteoporosis.

The woman facing the climacteric should be made to see it as a physiological process which calls for adaptation of various body organs to new conditions. During this adaptation any slight disturbances will correct themselves more quickly if she accepts them philosophically, and if she occupies her mind and body with interesting pursuits for which the new freedom of the postmenopausal era promises adequate time. Her husband should also be made aware of the significance of the menopause and of his wife's symptoms, and of the need for understanding and tolerance. Both partners should realise that it is normal and advantageous for coitus to be continued regularly. Should dyspareunia occur, which is unlikely if the practice is regular, a water-soluble lubricant can be prescribed to overcome dryness of the vagina. If the woman is fearful of a 'menopausal pregnancy', the taking of one of the oral contraceptives may be indicated.

### Medical

Those women who require more than explanation and encouragement but are reluctant to take hormone therapy sometimes find that small doses of sedatives help to control hot flushes.

Hypotensive agents such as clonidine hydro-chloride are sometimes advised. By blocking the sympathetic nerves centrally they can quieten vasomotor instability. But they are not without potentially serious adverse reactions, especially in women who are already hypertensive. When nervous symptoms predominate, tranquillizers may help.

### Hormone Replacement Therapy

Since menopausal symptoms are directly related to the result of deprivation of oestrogen, the administration of this hormone should relieve them completely. It can therefore be used as a therapeutic test to make sure that disturbances in any case are climacteric. Short-term low-dose oestrogen, in the absence of any absolute contraindication to its use, is a reasonable approach for the relief of severe menopausal symptoms. However, frequent re-evaluation of the patient is necessary.

About one-third of a woman's life is spent in the postmenopausal era and as a consequence the role of long-term hormone replacement therapy (HRT) is of relevance. The benefits, namely the prevention or control of vasomotor symptoms, insomnia, genital atrophy, coronary artery disease and osteoporosis, have to be balanced against the risks of iatrogenic disease as a consequence of medication. The greatest potential benefit of oestrogen therapy is the prevention of osteoporosis; oestrogen is considered by many authorities to prevent bone loss and osteoporosis *if* started before the disease is established and if maintained long enough. Exercise may have a similar beneficial effect; in countries where female labour is common and in women who partake vigorous exercise, bone demineralisation and fractures seem to be avoided, regardless of endocrine status. The actual or potential hazards of prolonged oestrogen therapy include cancer of the endometrium and breast, gall bladder disease and thromboembolism. The association between unopposed oestrogen therapy, endometrial hyperplasia and endometrial carcinoma is well established but can be countered by adequate progestogen therapy. The only real risk is that of breast cancer, the incidence of which is only marginally increased in current users up to 5 years (and may be up to 10 years) of therapy. Data for longer use are awaited.

Once the decision has been made to give oestrogen therapy, then the dose should be the lowest possible that gives symptomatic relief or has bone-sparing effect. It is necessary to review the patient regularly whether the patient is receiving short- or long-term therapy. Regular reviews are important in all women but particularly so in those who have a uterus.

### Oestrogen

Oestrogen acts at various levels on receptors all over the body. It also acts by inhibiting or reducing the output of gonadotrophins by the hypothalamic-pituitary system, though this is not consistent because of the loss of inhibin. If oestrogen is being prescribed for the relief of vasomotor symptoms, the effects can be judged by a daily hot flushes count. Natural oestrogens such as *conjugated equine oestrogens* can be used in a dose of 0.625 mg daily. If need be, the dose is gradually increased to achieve this effect. When the appropriate level is found, the same dose is maintained for one month and is then *very gradually* reduced over the course of 3 or 4 months. Gradual weaning is the secret of treatment, for if oestrogen is

discontinued suddenly symptoms return with renewed intensity. In order to mimic the natural cycle and to avoid continuous stimulation of the tissue, some authorities withhold treatment during one week out of every four; however, even this regimen does not give the patient an actual oestrogen-free interval due to storage and release in adipose tissue.

A disadvantage of this form of treatment is that many women fail to obey instructions about reducing the dose and, once having experienced the relief which oestrogens provide, continue to take them haphazardly over the course of many years. In such circumstances oestrogens are likely to cause uterine haemorrhage, endometrial hyperplasia and possibly carcinoma. Indeed, endometrial hyperplasia can develop in a young woman who has had radical intracavitary radium for a Stage 1 carcinoma of the cervix!

The standard daily dose for providing osteo- and cardioprotection has been found to be 0.625 mg of conjugated equine oestrogen. Equivalent doses of other oestrogens have been worked out.

*Ethinyl oestradiol* 10 µg, has been used orally for vasomotor symptoms but the dose-response effect on bone has not been sufficiently studied.

*Transdermal oestradiol patch* 50 µg twice weekly has a similar bone-sparing effect as 0.625 mg conjugated oestrogens. Its major advantage is that it avoids the hepatic first-pass effect; thus it lowers triglycerides and can be administered to women with hypertriglyceridaemia. However, there is a high incidence of local skin reaction due to the presence of alcohol, especially in tropical countries during the summer months. This problem is reduced with the use of the thinner matrix patches.

*Transdermal oestradiol gels* have obviated this problem. Daily application of 1.5 mg oestradiol has an efficacy equivalent to that of oral oestrogen.

*Oestradiol pellets* (25-50 mg) can be implanted subcutaneously twice a year. These take several months to be absorbed but should never be used alone in women who still have a uterus. Once a depot is established, treatment is beyond control. The place for *implants of oestrogen* is especially in young women subjected to hysterectomy and bilateral oophorectomy. An oestrogen implant spares them the effects of sudden deprivation of ovarian function. However, beneficial effects of transdermal oestrogens on lipoproteins may not occur because of the first-pass effect through the liver. Moreover, tachyphylaxis can occur over a period of time.

Oestrogens are well absorbed through the vaginal mucosa and while *vaginal creams* may be used to treat local genital atrophy, they are not the method of choice for long-term therapy. Some of the benefits gained by this treatment are related to the systemic rather than the local effect.

*Newer delivery systems* being developed include the continuous low-dose oestradiol-releasing vaginal silicon ring, which releases 5-10 µg oestradiol in 24 hours.

Oestrogens can be used alone only if the woman has already undergone hysterectomy. All women with an intact uterus, or even those who underwent hysterectomy for endometrial cancer (Stage I), endometrioid ovarian tumours or endometriosis, or those with severe osteoporosis should receive combined oestrogen-progestogen therapy or be considered for the selective oestrogen receptor modulators (*see below*).

#### *Combined Oestrogen and Progestogen Preparations*

With the possible exception of norethisterone, which is partly metabolised to an oestrogen, progestogens do not relieve climacteric symptoms. *It is now generally accepted that progestogens should always be given if oestrogen therapy is to be continued for longer than 2-3 months in a woman with an intact uterus.* Addition of progestogens is protective against endometrial cancer. Progestogens reduce oestrogen binding and are also capable of decreasing the amount of intracellular oestriol. They can be given cyclically, or in the form of a continuous combined regimen. For the perimenopausal woman, one of the lower-dose oral contraceptives may be appropriate, but these should be avoided in menopausal women as the amount of oestrogen is higher than that required. If an oestrogen preparation is used alone, it should be supplemented by progestogen for the last 10-12 days of treatment. Most treatment regimens are on a *cyclical* 3 weeks out of 4 basis, although the alternative of stopping treatment for the first 5-7 days of a calendar month is also popular. The advantage of having the oestrogen and progestogen preparations separate is that it allows the lowest possible dose of oestrogen to be determined for the individual patient. Medroxyprogesterone acetate 10 mg is administered daily for the last 10-12 days. Other options are dydrogesterone (10-20 mg), norethisterone (2.5 mg), desogestrel (150 mg) or micronised progesterone (200-300 mg). Of these, norethisterone has the potential for adverse effects on

the lipid profile but may be advantageous in osteoporosis.

The majority of women with a uterus will have withdrawal bleeding in the intervals between treatment. This is generally accepted by those women who wish to avoid climacteric symptoms, genital atrophy and preserve a youthful appearance and outlook. However, most women prefer not to have withdrawal bleeding and for them the *continuous combined regimen* is recommended in which the daily dose of oestrogen is combined with 2.5-5.0 mg medroxyprogesterone acetate or 0.35 mg norethindrone. Combined oestrogen—progestogen patches containing 50 µg of oestradiol and 250 mg of norethisterone are also available in some countries. Vaginal rings which release 15-20 µg of ethinyl oestradiol and 1 mg norethindrone acetate per 24 hours are also being developed. Nearly half the women on combination therapy will experience breakthrough bleeding in the first 6 months of therapy. Bleeding which persists beyond this time requires evaluation preferably by transvaginal sonography (TVS), hysteroscopy and endometrial aspiration. Giving patients a planned withdrawal every 3-4 months may decrease the incidence of, and be more acceptable than, an unscheduled breakthrough bleeding.

In *long cycle HRT*, 0.625 mg of conjugated equine oestrogen or its equivalent is administered for 70 days followed by 20 mg medroxyprogesterone acetate for 15 days. Placebo tablets are administered for the next 5 days to complete the 90-day cycle while allowing withdrawal bleeding.

Regardless of the therapeutic regimen, patients receiving oestrogen and progestogen therapy must have regular examinations. These should include examination of the breasts and genital tract, blood pressure monitoring and appropriate blood tests to check for any potential adverse endocrine or metabolic effects, i.e. blood sugar, liver function tests and lipid profile. Dual energy X-ray absorptiometry (DEXA) is the best index of bone mass but is not freely available in developing countries. Pap smear and TVS for evaluation of uterus, ovaries and endometrial thickness should be done annually and mammography performed every 2-3 years. Endometrial sampling may be required if there is persistent abnormal bleeding before or during HRT, or if the endometrium is markedly thickened on TVS. Combining the procedure with hysteroscopy improves the diagnostic sensitivity and specificity. Provided that proper medical supervision is maintained, the regular

taking of a 'youth pill' has benefits for *appropriately selected* post-menopausal women, especially those with an early menopause.

### *Mixed Oestrogen and Androgenic Preparations*

Except possibly when massive and virilising doses are used, androgens do not inhibit hypothalamic-pituitary gonadotrophic function and by themselves are of no value in the treatment of climacteric symptoms. But preparations containing 3-4 mg methyltestosterone and 30-50 µg ethinyloestradiol were used, the recommended dose being one to two tablets daily. The oestrogen is said to prevent virilism while the androgen is alleged to inhibit oestrogenic stimulation of the uterus and breasts. Both are protein anabolics. Oestrogen depresses the output of gonadotrophin and androgen gives a sensation of well-being and raises morale. The claims that one hormone cancels out the ill-effects of the other have an insecure foundation; certainly preparations of this kind can still cause uterine haemorrhage on the one hand, and hirsutism and voice changes on the other. If at all they have a place it may be in the treatment of depressed libido, where tibolone is either not available or not affordable.

### *Tibolone*

Tibolone is a gonadomimetic synthetic steroid, similar to the 19-nortestosterone steroids. It is metabolised into isomers with three major metabolites which have oestrogenic, progestogenic and androgenic effects respectively. These metabolites vary in their effect, on different target tissues. In the endometrium, tibolone and its metabolites have a weakly stimulatory effect because of a high progesterone receptor binding affinity. Thus tibolone produces beneficial effects on bone, vasomotor symptoms, genital tract, libido and mood changes in the standard 2.5 mg dose, but in the endometrium it generally induces atrophy. It has beneficial effects on coagulation factors, but not on lipoproteins. Total, HDL- and LDL-cholesterol are not altered; triglyceride levels decrease. It inhibits breast cell proliferation *in vitro*; *in vivo*, mammography pictures are more accurate because it does not increase the breast density like conventional HRT.

A major advantage of tibolone is its relatively low incidence of vaginal bleeding, seen mostly in small amounts within the first 4 months of therapy. It is also

suitable for women with leiomyomas and endometriosis, in whom conventional HRT can cause an aggravation of the condition. The major side-effects are weight gain and a bloated sensation. Some women complain of breast enlargement and tenderness and of gastrointestinal symptoms. Lower doses of 1.25 mg have been tried which, while offering some bone protection and other benefits, may be associated with a higher incidence of breakthrough bleeding.

### *Selective Oestrogen Receptor Modulators (SERMs)*

Two oestrogen receptors have been identified and are designated oestrogen receptor-alpha ( $ER-\alpha$ ) and oestrogen receptor-beta ( $ER-\beta$ ). Binding of the same oestrogen to different receptors can produce variable, even opposite, effects, e.g. binding of oestradiol to  $ER-\alpha$  can stimulate gene transcription whereas binding to  $ER-\beta$  will be inhibitory in some tissues and vice versa in others. The development of selective oestrogen receptor modulators (SERMs) has made use of this property to ensure that positive effects of hormone replacement therapy are effected on bone, lipids, brain, etc. while protecting from undesirable side-effects by an inhibitory action on the endometrium and breast. Raloxifene and tamoxifen are being intensively studied in this regard. Raloxifene prevents osteoporosis and is an advantage in those patients unsuitable for, or reluctant to use, hormone therapy but is not a substitute for oestrogen. Apart from bone, it has favourable effects on lipoprotein-a, LDL-cholesterol, homocysteine level and fibrinogen but does not affect HDL levels, does not benefit atherosclerosis and may even increase hot flushes and leg cramps. Tamoxifen has side-effects akin to oestrogen on bone mineral density and beneficial effects on coronary heart disease but has a stimulatory effect on the endometrium which precludes it from use for this purpose. Other SERMs such as draloxifene, idoxifene, toremifene, etc. are under evaluation.

### *Problems with HRT and Contraindications*

In spite of its many benefits, overall compliance with HRT is poor, with dropout rates as high as 40-60 per cent with conventional programmes. The main reasons for discontinuing HRT are vaginal bleeding, breast tenderness, nausea, vomiting, weight gain and the fear of breast cancer. Most of these symptoms settle after the first 2-3 months and may be less if therapy is initiated

with a lower dose, especially in older women who are well into the menopause. Fear of cancer and the general belief that hormones are not good for the system are also important reasons for discontinuing or turning to alternate methods of HRT (*see below*).

HRT is contraindicated in women with undiagnosed abnormal vaginal bleeding, breast lump, acute thrombosis, liver dysfunction, the acute phase of myocardial infarction and recently treated endometrial or breast cancer. Some relief of symptoms may be obtained in these women by lifestyle and dietary modifications and natural oestrogens.

### **Non-HRT Regimens**

Osteoporosis can be corrected by non-HRT methods such as the bisphosphonates, which have a direct inhibitory action on osteoclasts. Alendronate is most commonly used, a 10 mg dose being administered in the fasting state for a period of 3-5 years. Other agents are etidronate, paradronate and risedronate. Bisphosphonates are sometimes used in combination with HRT in severe cases of osteoporosis.

Salmon calcitonin has likewise been used when HRT is contraindicated (100 IU daily subcutaneously) but it is expensive and has the potential for immunologic reactions. It has the advantage of relieving the acute pain caused by subclinical vertebral fractures.

Slow-release sodium fluoride can be combined with calcium supplementation in a dose of 25 mg bd for a year followed by a gap for 2 months, up to a maximum of 4 years. It is effective in reducing the fracture rate.

### **Alternative Therapy for the Menopause**

Alternative therapy is increasing in popularity and one of the largest segments of this industry is therapy for menopause. This includes the use of vitamin and mineral supplements according to specific nutritional recommendations in addition to dietary modifications; herbal therapies including traditional Ayurvedic and Chinese medicinal formulas as well as European herbs; homoeopathic formulas; and mind—body medicine.

### **Neutraceuticals**

Vitamin E is an antioxidant which has been shown to decrease the risk of coronary artery disease by inhibiting the oxidation of LDL-cholesterol and inhibiting platelet aggregation. A minimum daily intake of 400 IU for

women less than 50 years of age and 600 IU for those over 50 years is recommended. Vitamin E supplementation has been shown to decrease fatigue, nervousness, dizziness, headaches, palpitations, joint pains and backache.

Supplementation of vitamins B<sub>6</sub>, B<sub>12</sub> and folic acid facilitates conversion of methionine (derived from homocysteine) to the harmless amino acid cystathionine and protects against cardiovascular disease.

All vitamins or minerals which work synergistically need to be supplemented adequately, else negative effects can result, e.g. vitamin E without adequate vitamin C can have a pro-oxidant effect.

### Natural Oestrogens

Phytoestrogens are compounds derived from plants. They have a weak affinity for the oestrogen receptors. Through this SERM-like action they act as both oestrogen agonists and antagonists.

There are many classes of phytoestrogens but the most important are the isoflavones which are found in legumes, especially soyabeans and chickpeas, and the lignans which are found in many fibre-rich foods, whole-grain cereals and nuts.

In animal studies, the isoflavone genestein has been shown to be equivalent to conjugated equine oestrogens in maintaining bone mass by stimulating osteoblast number and function and by inhibiting osteoclast activity. In women, 40 g of soya protein per day for a period of 6 months has been reported to increase the bone density by up to 2.2 per cent, but the beneficial effect of phytoestrogen on bone density has still to be established. Ipriflavone is a synthetic isoflavone which does not have oestrogenic effect but used in the prevention and treatment of osteoporosis.

Phytoestrogens have been found to be useful in reducing hot flushes, and may induce favourable changes in lipid metabolism and improve carbohydrate metabolism. High intake of phytoestrogens in the diet (>40 mg soya/day) has been correlated epidemiologically with a lower incidence of endometrial, breast and prostate cancers because of their SERM-like action.

### Herbal Therapies

Some herbs also contain oestrogen-like compounds, e.g. ginseng, red sage and dong quai, but there is not sufficient scientific data on these, and many herbal

preparations contain high levels of harmful heavy metals such as lead. Several herbs are known for their antidepressant effects, e.g. ginkgo biloba and St. John's wort. Valerian, kava and chamomile have sedative properties. Liquorice and ginger are added to some herbal formulas to relieve gastrointestinal symptoms commonly associated with the menopause.

## ABNORMAL MENOPAUSE

### Premature Menopause

It is rare for the menopause to occur before the age of 40 years, and the diagnosis of premature menopause should never be made until all other causes for amenorrhoea have been excluded. Nor should any symptoms ever be ascribed to the menopause unless they are accompanied by amenorrhoea. When the menopause does occur unusually early, there is often a history of a similar occurrence among other members of the family. Abnormal karyotype, hypothyroidism and autoimmune disorders including Addison's disease, pernicious anaemia and hypoparathyroidism have been linked with premature menopause.

No treatment is of any value because the ovaries are refractory. They are without ova if the amenorrhoea is truly menopausal. Gonadotrophin levels are raised and response to therapy is poor. Ovarian biopsy is not essential. Hormone replacement therapy is recommended to prevent long-term sequelae. However the role of oocyte donation in premature menopause for fertility needs to be considered.

### Late Menopause

Regular menstruation up to the age of 53 years is not uncommon and is of little significance. Beyond that age it should be regarded as unusual although not necessarily pathological, but if it continues beyond 55 years there is a clear indication for further investigation. The causes or associations of a late menopause are constitutional (a familial or racial tendency), uterine leiomyomas, diabetes mellitus, and an oestrogenic tumour of the ovary. The last causes irregular rather than cyclical bleeding.

Women who experience a late menopause are said to have an increased tendency to develop carcinoma of the body of the uterus later in life and this is one reason why the condition should not be neglected. Unless there is a strong family history, a delayed menopause may be

an indication for hysteroscopy, endometrial sampling and, occasionally, for hysterectomy.

### Artificial Menopause and Climacteric

#### *Surgical Menopause*

This is caused by removal of the uterus, ovaries or of both. If only the uterus is removed, and the blood supply of at least one ovary is not disturbed, ovarian function usually continues up to the normal age of the climacteric and no symptoms other than amenorrhoea develop. There are however, reports of declining ovarian function after hysterectomy even when both ovaries are conserved. In about 25-50 per cent of women ovarian function declines within 2-5 years after hysterectomy, especially in women who already have vasomotor symptoms. It is postulated that this may be caused by interruption of blood supply from the uterine artery. This is one of the reasons why all efforts are made to conserve the uterus in young women even if further reproductive function is not desired.

Removal of both ovaries from a woman who is still menstruating causes climacteric symptoms in 75 per cent of cases. The surgical climacteric is said to be more troublesome than the natural one because the ovarian influence is withdrawn suddenly rather than gradually, though this is not always true. Symptoms continue for 4-24 months after operation, tending to have a higher incidence but to persist for a shorter time in younger women. The rate of bone loss is greater in the first year after hysterectomy than it is in subsequent years or after a natural menopause.

#### *Radiation Menopause*

Ovarian function is suppressed by exposure to intense gamma radiation. Such treatment is likely to be followed by climacteric symptoms which are as intense as those following bilateral oophorectomy. In a woman less than 40 years of age, X-ray 'castration' may not be permanent, the effect lasting only a few years. Thereafter she may conceive and there is a theoretical risk of the fertilised ovum being abnormal. Moreover, conception can occur before the woman has any warning by way of a return of menstruation. The menopause can also be induced by inserting radium and other isotopes into the uterus. These act by destroying the endometrium but they also depress ovarian function. So climacteric symptoms ensue, their frequency and intensity being midway

between those which follow bilateral oophorectomy and those which occur at the natural climacteric.

### Follicle Stimulating Hormone (FSH) and Luteinizing Hormone (LH) in a Menopausal Woman

#### *Follicle-stimulating Hormone*

As the ovarian function declines in a woman the FSH and LH increases. The most consistent finding in the menopausal transition is an elevation of serum FSH levels. In fertile menstruating women, FSH on cycle day 3 should be 5 to 10 IU/L with normally functioning ovaries. In fact the quality of ovum is not very good when the basal levels of FSH is nearing 10 IU/L or when it is more than 10 IU/L. Elevated FSH levels (10 to 25 IU/L) suggest relative ovarian resistance consistent with the menopausal transition, even if oestradiol levels are in the normal range. Physiologically, this is believed to be the result of decreased inhibin production by the ovarian follicles during the last decade of menstrual function. However, levels of FSH >40 IU/L are consistent with complete cessation of ovarian function. Ovarian function can wax and wane over several years, and levels can fluctuate accordingly. Therefore, women with amenorrhoea and FSH >40 IU/L may resume menstruating for a short time in the future and occasionally may achieve pregnancy.

#### *Luteinizing Hormone*

In clinical practice evaluation of luteinizing hormone (LH) levels appears to be of somewhat less value than other hormone assessments during the menopausal transition. In a normally menstruating woman the LH is usually less than 10 IU/L and it is elevated in a PCOS woman. Prior to menopause, LH levels are usually in the range of 5 to 20 IU/L. However it is necessary to check both LH and FSH in women, especially young patients, with apparent loss of ovarian function.

### OVULATION

#### *Ovulation and the Menopause*

It is generally asserted that menstruation is frequently anovular during 5-10 years before the menopause and this is put forward as an explanation of lowered fertility after the age of 40 years. One of the few reported investigations into this matter showed that in women

aged 40-45 years, 75 per cent of cycles were ovular, and that in women aged more than 46 years, 60 per cent of cycles were ovular. Ovulation certainly continues sporadically if not regularly up to the time of the menopause and sometimes after wards. In England and Wales, prior to liberalisation of the abortion laws, 20-30 (1 in 28000) births each year occurred amongst women aged 50 years and over; in the USA, 1 in 20000 babies born had mothers aged 50 years or more. Most of the women who conceive late in life are still menstruating but there are reliable reports of conception occurring several months up to 11 years after the assumed menopause. In view of this, women should be advised not to discontinue contraceptive precautions until 2 years after the last menstrual period. After this time the risk is so slight as to be negligible.

Spontaneous ovulation has been demonstrated, and pregnancies recorded, in women aged 52 years. The Editor of the Guinness Book of Records was convinced of the authenticity of reports of babies being born to women aged 54 or 55 years (in Britain, 1956); and 57½ years (in USA, 1956). (With assisted reproduction technology, a woman aged 63 years has now given birth to a child).

Many women have the idea that there is an increased likelihood of conception at the change of life. This is not true; however, women may become careless about contraception as the menopause approaches.

### Ovulation and Lactation

See chapter 11.

### Diagnosis of Ovulation

It is sometimes clinically important to be able to determine if and when a woman is ovulating, and to distinguish between ovular and anovular menstruation. The following methods are available.

### Analysis of Symptoms

#### *Cyclical Bleeding*

The occurrence of regular normal menstrual losses is strong presumptive evidence of monthly ovulation.

#### *Ovulation Pain (Mittelschmerz)*

Many women feel some discomfort in the hypogastrium, or in one or other iliac fossa, for 12-24 hours just before or just after ovulation. An awareness of its

significance allows them to determine the approximate time of their ovulation.

#### *Ovulation Bleeding or Discharge (Mittelblüt)*

Some women experience a slight loss of blood or of mucus tinged with blood at the time of ovulation. This may be associated with ovulation pain although each can occur independently. Those women who do not have obvious bleeding may notice an increase in the natural discharges. Occult ovulation bleeding, or the presence of glucose in the secretions (a postovulation phenomenon), can be detected if tampons or paper strips impregnated with appropriate chemicals are inserted into the vagina daily.

#### *Premenstrual Mastalgia*

Premenstrual pain and tenderness in the breasts is in some way related to corpus luteum action, so its occurrence is fairly reliable evidence that ovulation has occurred during that particular cycle.

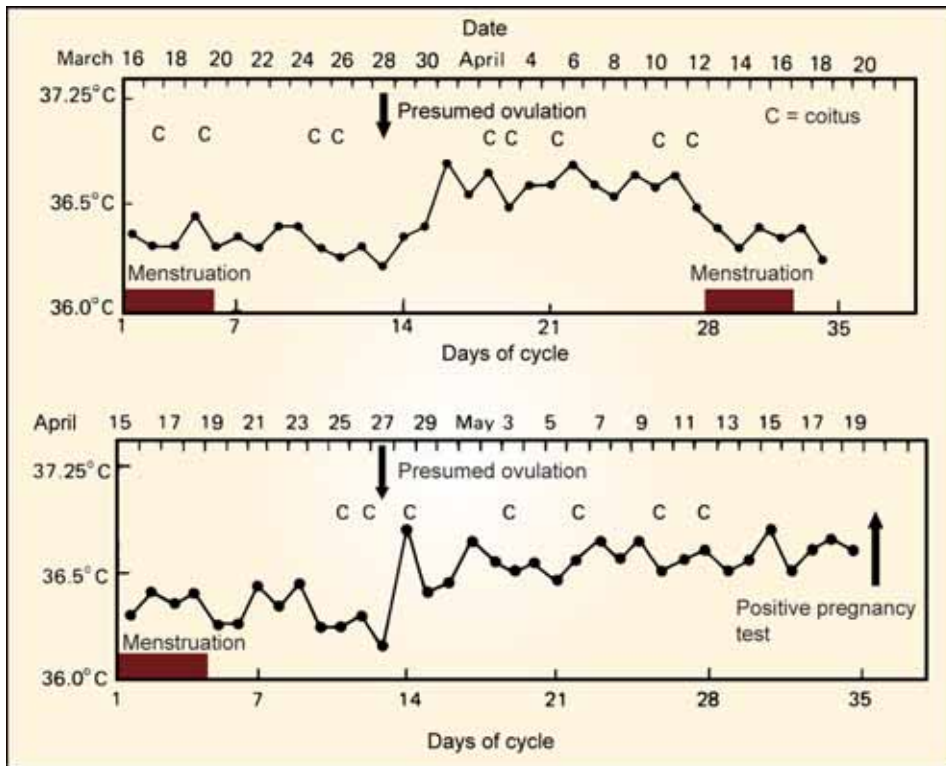
### Temperature Changes

The body temperature is raised by progesterone and is therefore higher during the luteal phase of the cycle and also during pregnancy. During the later part of the menstrual flow and during the follicular phase the temperature is relatively low. Ovulation is sometimes preceded by a low peak and is generally followed by a rise. However, a monophasic temperature chart does not always mean that ovulation has not occurred. The rise may occur suddenly within 24 hours or gradually over 4 days. After this the temperature remains 0.2-0.5°C higher than in the follicular phase until the onset of the next period (Fig. 5.1). This biphasic chart is evidence of ovular as opposed to anovular menstruation, and the thermal shift is a fairly accurate indication of the time of ovulation.

For this test to be of value it is essential for the temperature to be recorded daily under standard conditions, before rising from bed in the morning and before eating or drinking. The drawbacks of this test are its poor correlation with hormone levels and the inconvenience to the patient.

### Endometrial Changes

The *time* of ovulation cannot be determined accurately by histological changes in the endometrium, but the fact



**Fig. 5.1:** The biphasic basal temperature chart typical of an ovular menstrual cycle. If pregnancy occurs the temperature remains at a relatively high level

that it has occurred previously can be deduced by recognising secretory activity in the glands during the week preceding, or at the onset of, menstruation. Such activity is highly reliable evidence of corpus luteum formation.

*Endometrial biopsy or aspiration* for this purpose can be carried out on the unanaesthetised patient without causing more than slight momentary discomfort. It is important that it is the surface endometrium and not the unresponsive basal layer which is examined.

### Changes in Cervical Mucus

The different effects of oestrogen and progesterone on the physicochemical properties of cervical mucus are utilized in *the fern test*. Mucus is collected on cotton wool, spread thickly on a glass slide and allowed to dry. The fern pattern (Fig. 5.2) is seen under a low-power microscope from the sixth to the twenty-second day of



**Fig. 5.2:** The fern test. Crystallisation of cervical mucus on a glass slide to produce the pattern of a fern leaf (arborisation). This phenomenon reflects an oestrogen influence and does not occur when progesterone is dominant



the cycle after which it is non-existent. A failure to demonstrate ferning during the premenstrual week, after a positive finding earlier in the same cycle, denotes a dominant progesterone influence and suggests that ovulation has occurred. In performing this test it is essential to prepare the glass slide by washing it in *distilled* water. The electrolytes in tap water prevent the crystallisation of mucus, and so does contamination of the mucus with blood or semen.

### Vaginal Smears

Provided that there is no complicating pathology to confuse the picture, the daily examination of vaginal smears from the lateral vaginal wall by an expert will pinpoint ovulation quite well. The superficial cells increase in number towards mid-cycle and the number of intermediate cells declines gradually. A single smear taken in the second half of the cycle shows reliably whether a corpus luteum has formed. The intermediate cells now predominate. They have basophilic cytoplasm and large, pale, vesicular nuclei. The number of polymorphs increases. At menstruation, there is considerable debris with red and white blood cells and histiocytes.

### Hormone Assays

Ovulation can be reliably confirmed by an estimation of the mid-luteal phase plasma progesterone level, i.e. 5-8 days after ovulation. A minimum of 6.5 ng/ml is taken to indicate ovulation.

Prediction of ovulation is possible by detection of the preovulatory LH surge which precedes follicle rupture by 34-36 hours. Radioreceptor assays can estimate the levels of LH in plasma and urine within 2 hours of collecting the sample. Various kits utilise erythrocytes coated with anti-LH antibody; their different rates of sedimentation in the presence or absence of LH gives an effective measure of the levels of LH, to enable the initiation of the surge to be detected rapidly. This demands repeated sampling to time the initial rise in LH which is related to the follicle rupturing some 36 hours later. This information is helpful in relation to the timing of artificial insemination or the timing of oocyte collection. The study of daily oestrogen and progesterone levels is only likely to be undertaken in women in whom ovulation is being induced with gonadotrophins.

### Ultrasound

The modern real-time ultrasonic apparatus has been used to describe ovarian and follicular characteristics throughout spontaneous and stimulated ovulatory cycles. It thus allows criteria to be set by which abnormal and possibly inadequate cycles may be identified prior to follicular rupture. This is helpful in the induction and confirmation of ovulation, artificial insemination and *in vitro* fertilisation. The wide range of follicular size of the dominant follicle still makes it impossible to predict the precise time of ovulation.

Once ovulation has occurred the follicle appears as a smaller, irregular cyst which progressively decreases in size over the next few days. Internal echoes are seen within the follicle. Occasionally the follicle disappears completely. Sometimes, fluid is seen in the pouch of Douglas.

### Direct Observation

Recent ovulation can be diagnosed by the finding of an active corpus luteum on inspecting the ovary during laparoscopy or laparotomy.

### Ovarian Dysfunction

Ovarian dysfunction is classified into seven main groups (WHO 1976).

*Group I.* Hypothalamic-pituitary failure, e.g. anorexia nervosa, Kallman's syndrome, Sheehan's syndrome.

*Group II.* Hypothalamic-pituitary dysfunction, e.g. polycystic ovarian syndrome (PCOS), congenital adrenal hyperplasia (CAH), adrenal tumours, androgen-producing ovarian tumours.

*Group III.* Ovarian failure, e.g. Turner syndrome, pure gonadal dysgenesis, Swyer syndrome, autoimmune disorders, infection (e.g. mumps), radiotherapy or chemotherapy.

*Group IV.* Congenital or acquired genital tract disorders, e.g. imperforate hymen, Mayer-Rokitansky-Küster-Hauser syndrome, Asherman's syndrome.

*Group V.* Hyperprolactinaemia with a space-occupying lesion (SOL) in the hypothalamic-pituitary region, e.g. pituitary adenoma.

*Group VI.* Hyperprolactinaemia without an SOL in the hypothalamic-pituitary region, e.g. hypothyroidism, chronic renal failure, drug-induced.

*Group VII.* Amenorrhoea with an SOL in the hypothalamic-pituitary region with normal or low PRL, e.g. craniopharyngioma.

### Treatment

The detailed treatment of all groups is discussed in the respective sections. Groups I and II are treated by induction of ovulation (*see below*) if they desire pregnancy. Group III patients will not respond to induction of ovulation but can be considered for oocyte donation. The management of group IV patients is discussed in Chapter 13. Groups V and VI are treated with dopamine agonists but may require induction of ovulation as well. Group VII need neurosurgery.

### Treatment of the Cause

When general diseases such as diabetes, thyroid dysfunction, tuberculosis and anorexia nervosa are the basis of anovulation, treatment should be directed to cure these. Nevertheless, in resistant cases of anorexia nervosa, ovulation can be induced by gonadotrophin therapy.

### The Induction of Ovulation

The induction of ovulation in clinical practice is only indicated when the object is to give a woman, infertile by reason of anovulation, a chance to conceive. *It is not justified in the treatment of amenorrhoea alone.* Moreover, no method can succeed unless the ovaries contain oocytes. This means that it is pointless to attempt to induce ovulation in the postmenopausal woman or one suffering from streak gonads. Elevated serum gonadotrophin levels coupled with lack of withdrawal bleeding on progesterone challenge indicate ovarian failure.

Before treatment is planned it is necessary not only to be reasonably certain that ova are available for stimulation but to exclude the presence of all other possible bars to conception, male and female. This having been done, the methods whereby ovulation may be induced are as follows. Their results are always difficult to compute because of the possibility of ovulation occurring spontaneously irrespective of treatment.

#### Clomiphene

This substance is an analogue of the synthetic non-oestrogen chlorotrianisene, distantly related to

diethyl stilboestrol (DES). The usual commercial preparations comprise a mixture of the *cis* and *trans* isomers of clomiphene citrate, now redesignated zuclomiphene and enclomiphene citrate, the former being the mainly active principle. Taken by mouth, they are rapidly absorbed and are metabolised in the liver. Although mildly oestrogenic in some animals, clomiphene acts mainly as an anti-oestrogen in the human being. It competes with natural oestrogens for receptors on the specific oestrogen binding proteins and blocks their inhibitory action on the hypothalamic-pituitary system. The overall effect of clomiphene is therefore to bring about a release of gonadotrophins. An upsurge in the plasma level of FSH and LH is demonstrable after clomiphene administration. It is also suggested that clomiphene may potentiate ovarian sensitivity to gonadotrophins.

It follows that if clomiphene is to effect ovulation, the hypothalamic-pituitary system must be intact and capable of function. It is useless, for example, in cases of Sheehan's syndrome. Some degree of ovarian activity also seems essential so, before clomiphene therapy is applied, it is necessary to establish, directly or indirectly, that the patient is producing a certain amount of endogenous gonadotrophins and oestrogens. The best results are seen when the level of the former is low and that of the latter is high. Some of the best indications for clomiphene therapy are the polycystic ovary syndrome and the Chiari-Frommel syndrome, amenorrhoea and anovulation following the use of oral contraceptives, and infrequent ovulation and menstruation.

Clomiphene is a powerful drug and should not be given empirically. It is strongly contraindicated in the presence of impaired liver function. It is teratogenic when given in large doses to animals, so pregnancy should be excluded for certain before it is used.

The initial course of treatment consists of 50 mg clomiphene daily given orally for 5 days. This can be commenced at any time in the amenorrhoeic woman but, for the woman who has regular anovular menstruation, the starting point is usually the fifth day of the menstrual cycle. (In IVF programmes, treatment is started from the second day to recruit more follicles). The treatment is monitored by daily charting of basal temperature and serum oestradiol levels or ultrasound for confirmation of ovulation, if practical. If it is successful, ovulation occurs 7-12 days after the last day of treatment and coitus should be timed accordingly. If it fails, further courses

of treatment can be related to the periods or at 30-day intervals in amenorrhoeic women if regular menses are not re-established. It is reasonable to increase the dose, if there is no evidence of ovulation or untoward reactions, to 100 mg or even 150 mg. If there are large cysts during observation of the follicular growth then the persistence of the cyst should be evaluated on Day 2 of menses since the next cycle of CC can be started only if there are no cysts.

In general, no more than 150 mg of clomiphene is given in one day. Moreover, if the ovaries do not respond to six courses of treatment it is useless to give any more, and it may be dangerous to do so. Although the possible ill-effects of long-term treatment are unknown, there are stray reports of an increased likelihood of ovarian cancer in women who had received ovulation induction with clomiphene for prolonged periods.

Women vary in their sensitivity to clomiphene and even small doses sometimes overstimulate the ovaries to make them the seat of pain, enlargement, cystic change, haemorrhage and multiple ovulation. Other, side-effects include hot flushes (which occur in 10 per cent of cases and which coincide with peak releases of LH), nausea and vomiting, headaches, visual disturbances, alopecia (rare) and galactorrhoea (rare). Such patients can often be successfully treated with 25 mg daily for 5 days, or sometimes even for 3 days.

In well-selected cases clomiphene induces ovulation in 70 per cent but conception does not always result. This may mean that the evidence for ovulation is not always reliable and may reflect pseudo-ovulation or luteinisation of an unruptured follicle due to clomiphene-induced inhibition of prostaglandin synthesis. Another possibility is that the anti-oestrogenic action of clomiphene makes the cervical mucus unreceptive to spermatozoa. Pregnancy occurs in 40-50 per cent of women following treatment and, even though the dosage is carefully controlled, 5-10 per cent of the conceptions are multiple.

Some patients with hyperinsulinaemia will not respond to clomiphene and there is emerging evidence that correction of the hyperinsulinaemia with metformin 500 mg tds will effect ovulation. If an ovulatory response is not seen in three months, clomiphene is re-started in addition, beginning at the lowest doses. Metformin should not be administered to women with compromised renal function.

### *Tamoxifen*

This is a triphenylethylene compound which has anti-oestrogenic properties, probably because it competes with oestrogen for binding sites in target organs. It is an alternative to clomiphene and used for the same type of case. The usual dose is 10 mg twice daily on the second, third, fourth, fifth and sixth days of the menstrual calendar. The dose may be increased, if there is no evidence of ovulation, to 20 mg twice daily and, if there is no response, up to a maximum of 40 mg twice daily. In women who are not menstruating, subsequent courses are recommended at 45 day intervals. If the patient responds with menstruation, the next course of treatment starts on the second day of the period.

It is often a matter of personal choice as to whether one uses tamoxifen or clomiphene. Since some women respond to one of these drugs and not the other, it is not unusual for the alternative preparation to be given after a 3-4 month gap following six unsuccessful courses (the maximum recommended). There appears to be a rebound phenomenon with each preparation, for some women conceive shortly after completing a course. Patients on tamoxifen should be monitored as for clomiphene.

### *Corticosteroids*

In congenital adrenal hyperplasia regular treatment with small doses of cortisone or allied products usually corrects the ovarian function. The same is true for Addison's disease (adrenal cortical failure), the occult form of which is characterised by anovular, although often regular, menstruation. Without such clear indications for it, however, corticosteroid therapy is not of any value.

Dexamethasone has been added to clomiphene in women with hirsutism and high DHEAS levels. Daily administration of 0.5 mg at bedtime blunts the ACTH peak.

### *Gonadotrophins*

When ovulation is arrested because of a failure in the production of gonadotrophins by the hypothalamic-pituitary system, the logical treatment is to administer these hormones. They may also be tried when the more simple clomiphene therapy fails to produce ovulation. Indeed, except when pituitary failure is clearly established, the above methods should be applied before

resorting to gonadotrophin therapy. Induction of ovulation with gonadotrophins has also been accomplished in hypophysectomised hypogonadotrophic women.

All patients considered for gonadotrophin therapy will have been screened to exclude causes of amenorrhoea and anovulation treatable by other means. It is important that, if gonadotrophin therapy is considered appropriate, both husband and wife appreciate what is involved and are aware that treatment is costly and dangerous, and that success cannot be guaranteed. In most centres the number of treatments will be limited; we usually restrict it to six successful ovulations; ideally these should be confirmed biochemically.

Gonadotrophin therapy should only be given in centres where appropriate facilities are available to monitor each treatment cycle in detail. Extreme caution is required when anovulation is associated with cystic ovaries, because of the high risk of an excessive ovarian response. Since each treatment schedule has to be tailored to suit each individual patient, and modified according to daily responses, it is a matter for experts in the field. Several preparations of gonadotrophins are available. The oldest is human menopausal gonadotrophin (hMG) extracted from the urine of postmenopausal women with 75 IU each of FSH and LH per ampoule; purified urinary FSH, and recombinant FSH which can be administered subcutaneously are also available. If day 3 LH levels are low, hMG is a better choice, whereas if LH is high, pure FSH is a better choice. Human chorionic gonadotrophin (hCG), recombinant hCG and recombinant LH are also available.

Follicle stimulation is achieved by daily administration of gonadotrophin for 7-14 days. It is customary to start with 75 IU (one ampoule) daily from day 2 and assess the response by ultrasound, preferably vaginal, to assess the number and size of the follicles. Circulating oestradiol is periodically assessed, if possible. On the seventh day, further dose assessment is done depending on the response and the same dose is continued or it is stepped up. In the step-down method, the initial dose is higher (2-3 ampoules per day) and is reduced to one ampoule after the initial recruitment of follicles, thus mimicking the normal FSH changes.

Patients with polycystic ovaries are at greater risk of hyperstimulation and need earlier monitoring and lower doses.

Once the follicle has reached a size of 18-20 mm, the endometrium is showing the characteristic triple line and thickness of 9-10 mm, and the serum oestradiol level is 1000-1500 pg/ml, an ovulatory stimulus is given, either by 5000-10,000 units of hCG or 0.1 mg of triptorelin. The former mimics the LH surge and the latter stimulates it. The patient is advised to have intercourse regularly on that day and the next two days. Even when the optimum dosage has been determined, stringent monitoring of every course of treatment is essential because ovarian sensitivity varies from time to time and the activity of the ampoules of the commercial hormone preparation is not constant. Moreover, ovulation sometimes occurs without hCG being given, this being explained by the fact that preparations of hMG contain variable amounts of LH.

The postovulation phase is also monitored since it helps to determine a subsequent dose of FSH, should further treatments be required. Ovulation results more frequently than does conception, but overall the pregnancy rate should be at least 50 per cent with good selection and has been reported to be as high as 90 per cent in group I patients. The multiple pregnancy rate is about 20 per cent, with multiples over two forming 2-5 per cent. Despite all precautions, there is clinical evidence of ovarian hyperstimulation in not less than 2-5 per cent of treatment cycles.

**Ovarian hyperstimulation syndrome:** The ovarian hyperstimulation syndrome (OHSS) is an iatrogenic condition. It has a varied spectrum but is usually manifested by ovarian pain, haemorrhage, enlargement and cystic change (Fig. 5.3). Haemorrhage in particular can give rise to an 'acute abdomen' and to unnecessary laparotomy. Any discomfort, with or without fainting, is most likely to commence 2-4 days after the administration of hCG; it increases for 7 days and wanes during the next 7 days. The patient should be warned accordingly. Another possible side-effect is a painful reaction and swelling in the tissues at the injection sites.

When treatment has been less well controlled there have been cases of serious complications and a few fatalities have been recorded. In these, and probably as a result of a high level of ovarian steroids in circulation affecting the vascular tree, electrolyte levels and renal function, there have developed hypovolaemia, renal failure, a shift of protein from the plasma to the peritoneal, pleural and rarely the pericardial cavities with



**Fig. 5.3:** Gross enlargement of the ovaries complicating treatment with human gonadotrophins and resulting in a tumour arising out of the pelvis and extending as high as the umbilicus. This developed 7 days after the giving of hCG preceded by FSH. The patient conceived during this cycle of treatment and the enlargement of the ovaries subsided only very gradually during the first 3-4 months of pregnancy

consequent ascites and hydrothorax (pseudo-Meigs' syndrome), and venous thromboembolism. Massive intraperitoneal haemorrhage from the ovaries is also described. Adult respiratory distress syndrome (ARDS) is a rare but life-threatening complication which can lead to cardiac arrest. Based on clinical, laboratory and ultrasonographic findings OHSS is subdivided into mild, moderate and severe classes. If the ovaries are less than 8 cm in diameter and the patient complains of abdominal bloatedness, heaviness, tension or swelling with mild pain, the case is categorised as mild.

In moderate OHSS, the ovaries are 8-12 cm in diameter, ascites may be detected on ultrasound, all symptoms are more severe and may be accompanied by nausea and vomiting.

In severe OHSS, the ovaries are > 12 cm in diameter, there is clinical ascites, sometimes hydrothorax. Laboratory assessment reveals haemoconcentration, hypoproteinaemia and electrolyte disturbance. There is hypovolaemic perfusion.

Management aims to provide symptomatic relief and prevent complications. In mild OHSS, outpatient management may suffice and the condition resolves with the onset of menstruation. Paracetamol and opiates are safe but NSAIDs should be avoided as they interfere with the dispersion of the cumulus oophorus and ovum release. Anti-emetics, adequate fluid intake orally or parenterally and discontinuation of hCG with changeover to progestogen are important ancillary measures. In moderate OHSS the cysts take 2-4 weeks to resolve, but in conception cycles they may take longer. Elastic stockings reduce the risk of thromboembolism.

The treatment of severe OHSS is to admit the patient and put her on bed rest with strict intake-output charting, frequent monitoring of vitals and daily weight record. The haematocrit, blood urea, serum creatinine, electrolytes, serum proteins with albumin-globulin ratio, coagulation studies and electrocardiogram are monitored serially. Plasma expanders, human albumin and electrolyte supplements are administered to restore the plasma volume and correct the electrolyte imbalance. Removal of the fluid from the pleural and peritoneal cavities may be required if life-threatening ARDS develops. Heparinisation is indicated in severely haemoconcentrated patients to prevent arterial and venous thromboses. Termination of pregnancy or surgery for haemorrhage or rupture of the cysts is rarely required.

The incidence of OHSS can be reduced by careful monitoring of serum oestradiol and serial ultrasonography. If serum oestradiol levels are high or there are a large number of maturing follicles, hCG is withheld and the cycle is cancelled; or, if facilities permit, the oocytes are collected for cryopreservation. These patients are asked to weigh themselves daily. If weight gain is >5 kg or any of the other symptoms develop, they must come to the hospital. Using GnRH agonists instead of hCG for ovulation induction reduces the incidence of OHSS. All CC cycles must be monitored by sonography for response or hyperstimulation.

### *Clomiphene and Gonadotrophins*

When clomiphene alone fails to produce ovulation, it is supplemented with hCG 5000-10000 IU which mimics the LH surge.

The combination of clomiphene with FSH and LH decreases the requirement of gonadotrophins and therefore the cost of therapy. Clomiphene administration is begun on the second or third day of the cycle with 100 mg daily for 5 days and then 2 ampoules of gonadotrophins are administered daily or on alternate days with monitoring as described above. If the response is not seen with 100 mg CC it is ideal to add Gonadotrophins to CC for few days (CC 100 mg Day 2-6 plus add Gn 75 IU from Day 7 to 10 for better response or give only Gn.

### *Bromocriptine*

Although this drug does not specifically induce ovulation, it is the drug of choice for those women with amenorrhoea and/or infertility associated with

hyperprolactinaemia. A raised level of prolactin is thought to cause anovulation by a central and/or peripheral effect at the hypothalamic level by inhibiting the release of GnRH and hence FSH and LH, and peripherally by antagonising the effects of LH and FSH on the gonadal ovulatory processes. The drug may also be used for those women who have normal prolactin levels but who have not ovulated with courses of clomiphene or tamoxifen, before considering using gonadotrophins for inducing ovulation. In most instances, irrespective of the final dosage, the optimum response with the minimum of side effects is best achieved by the gradual introduction of bromocriptine. It is recommended that the tablets should be taken with food, starting with one tablet (2.5 mg) at bedtime, increasing after 5-7 days to two tablets. The dose may then be increased by a further tablet 5-7 days later until the a dose of 2.5 mg three times daily is reached. In infertile patients without an elevated serum prolactin level, the usual dosage is 2.5 mg twice daily. The lowest effective dose should be the objective of treatment in women with normal prolactin levels to avoid suppressing the prolactin level too much, since this would impair luteal function. Therefore, during the regular assessments the prolactin levels should be checked, since the duration of treatment will usually last 6-9 months if pregnancy does not occur. Bromocriptine should be discontinued if pregnancy occurs, although there is no evidence of any teratogenic effects.

#### *Hypothalamic Releasing Factors (GnRH)*

When the anterior pituitary gland is intact and capable of function, for example, when anovulation follows inhibition of the hypothalamus, it would appear appropriate to administer releasing factors instead of gonadotrophins. There are problems in administering GnRH because it has a very brief half-life and has to be given continuously in a pulsatile fashion by portable infusion pumps. This method is effective in women with hypothalamic amenorrhoea who do not have menstrual bleeding following a progestin challenge because of deficiency of endogenous GnRH. It is also effective in women with hyperprolactinaemia who cannot tolerate bromocriptine.

The pump has to be worn constantly. Drug administration may be intravenous or subcutaneous, doses being 5 mg and 20 mg per bolus, respectively every 90 minutes with the dose being increased in 5 mg

increments if required. Intravenous administration requires heparinisation.

After ovulation, the pump may be continued or alternatively hCG 2000 IU is given intramuscularly every 3 days for luteal support.

The pregnancy rate after 6 cycles is 80 per cent; with polycystic ovaries it is 30-40 per cent. The incidence of multiple pregnancy is low. In spite of its physiological action and advantages, the pump has not been accepted well by patients and is not available in many countries.

#### *GnRH Agonists and GnRH Antagonists*

Women with elevated basal levels of LH, e.g. women with PCOS have a poorer response to hMG treatment and a higher rate of abortion. In such women GnRH agonists are administered to convert these patients to a hypogonadotrophic state. GnRH agonists desensitise and downregulate pituitary GnRH receptors. Thus endogenous hormone production is shut off. Removal of the premature LH release improves the pregnancy rate, decreases the abortion rate and may even decrease the risk of ovarian hyperstimulation.

Administration of GnRH agonists causes an initial stimulatory response, the 'flare', which results in enlarged follicular cysts if the agonist is administered in the follicular phase or to anovulatory women. To obviate this problem, treatment is started in the mid-luteal phase of the previous cycle. The agonists are administered subcutaneously (e.g. leuprorelin 500 µg bd or 3.75 mg im) or intranasally (e.g. nafarelin 200 µg bd). Complete downregulation takes 7-10 days if started in the midluteal phase and about 3 weeks if started in the follicular phase. At this time patients develop menopausal-like symptoms but these disappear once hMG is started.

Following downregulation, hMG administration is started (Fig. 5.4). Higher doses of gonadotrophins are usually required following GnRH therapy which implies increased cost of therapy. The agonist is administered daily throughout the duration of gonadotrophin treatment until hCG is administered. Luteal support with hCG or progesterone is essential to compensate for the suppressed endogenous LH level. False-positive pregnancy tests can result from the luteal phase administration of hCG.

High LH levels have a negative role in IVF, so reduction in bioactive LH levels in the serum is desirable,

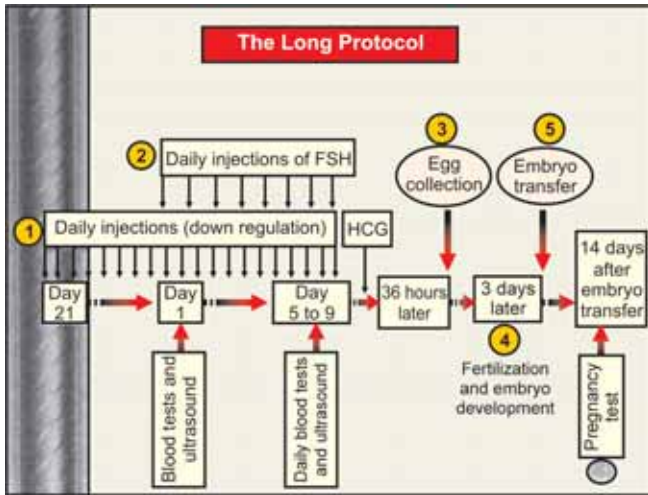


Fig. 5.4: Showing long protocol of GnRH-agonists

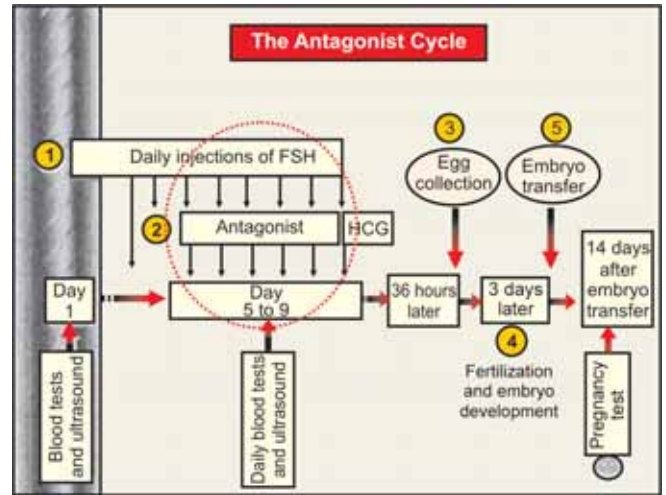


Fig. 5.5: Showing protocol with antagonists

particularly in the light of evidence associating raised LH levels in the follicular phase with adverse reproductive outcomes:

- Reduced fertilisation and pregnancy rates.
- Increased spontaneous abortion rate. Most specialist infertility clinics attempt to minimise premature LH surges using pituitary down-regulation. To achieve this, gonadotrophin-releasing hormone agonists (GnRH-a) were introduced into IVF superovulation regimens in the late 1980s and have become established as a component of standard regimens in most centres worldwide.

The inclusion of GnRH-a in ovarian stimulation protocols for assisted reproduction technologies (ART) has resulted in significant improvements in outcome:

- Cycle cancellation rates have decreased.
- Clinical pregnancy rates have increased. In fact, before GnRH-a became available, approximately 20 per cent of stimulated cycles within an IVF program were cancelled due to premature LH surges. By using the GnRH-a to prevent LH surges via gonadotrope GnRH receptor (GnRH-R) down-regulation and desensitisation, this percentage decreased to about 2 per cent, and concomitantly, the IVF and pregnancy rates (PR) per cycle initiated were increased.

Several treatment schedules currently are in use (long, short, or ultrashort protocol): the *long protocol*, in which the GnRH-a is begun in the luteal phase of the

cycle preceding the treatment (stimulation) cycle and down-regulation occurs before the start of the gonadotrophin-stimulation treatment phase, is generally the most effective regimen and is presently the most frequently used protocol. However, it has some disadvantages, such as hypoestrogenic side effects and an increase in the number of ampoules of FSH or hMG required for adequate stimulation.

Low doses of the native peptide delivered in a pulsatile manner to mimic that found in the hypothalamic portal vessels restore fertility in hypogonadal patients, and are also effective in treating cryptorchidism and delayed puberty. Administration of high doses of GnRH or agonist analogues causes desensitisation of the gonadotrope gland with consequent decline in gonadal gametogenesis and steroid and peptide hormone synthesis. This phenomenon finds extensive therapeutic application in clinical medicine in a wide spectrum of diseases and in IVF to avoid LH increase. In addition, GnRH analogues could be used as new generation male and female contraceptives in conjunction with steroid hormone replacement.

GnRH-antagonists (GnRH-ant) inhibit the reproductive system through competition with endogenous GnRH for the receptor and, in view of their rapid effects, are being increasingly used for the above mentioned applications. GnRH antagonists are started midcycle to suppress LH. Hence the dose of gonadotrophins are reduced. GnRH antagonists causes immediate suppression of LH (Fig. 5.5).

## Surgical Procedures

Wedge resection of the ovaries was earlier practiced in patients with polycystic ovaries who did not respond to medical induction of ovulation. Removal of stromal tissue resulted in decreased androgen and inhibin levels with a consequent rise in FSH levels and subsequent ovulation.

Most centres have now replaced wedge resection with laparoscopic procedures. The procedure is reserved for those women where an adequate trial of medical induction has been unsuccessful. The ovaries are 'drilled' using cautery, diathermy or laser through the laparoscope. Multiple punctures are used, varying from 4 to 20 per ovary, following which there is spontaneous ovulation or at least an increased sensitivity to clomiphene. However adhesions may develop in about 10-15 per cent of cases. Severe haemorrhage may occur. Excessive tissue destruction has also been reported to result in premature ovarian failure, so current trials are evaluating the place of lesser punctures which may even be restricted to one ovary. The effect is temporary. Better results have been reported with cautery than with laser.

## Suppression of Ovulation

The causes and means of suppression of ovulation are as follows.

### *Disease*

Ovulation is suppressed by psychoses and neuroses; by diseases affecting the hypothalamus, pituitary, ovary, thyroid, pancreas and adrenals; by metabolic disorders, including starvation and obesity; and by debilitating diseases of many kinds. In these circumstances, ovarian failure is usually accompanied by amenorrhoea or oligomenorrhoea.

### *Drugs and Other Therapeutic Agents*

Certain drugs, notably chlorpromazine and its derivatives, and possibly reserpine, can sometimes arrest

ovulation in susceptible women. They probably act via the hypothalamus, through prolactin. Some chemotherapeutic drugs, notably mustard-type alkylating agents and busulfan may cause permanent anovulation. Other drugs which have been implicated include the vinca alkaloids, bleomycin, cytosine arabinoside and hydroxyurea. Electroconvulsive therapy can have a similar effect.

### *Irradiation*

It is possible to suppress ovulation temporarily or permanently by exposing the pituitary gland or the ovaries to ionising radiations.

### *Oestrogens and Progestogens*

Ethinylestradiol, 0.05-0.1 mg, administered daily from the fifth day of the cycle onwards, prevents ovulation by inhibiting the production of gonadotrophins. This is evidenced by the fact that it eliminates the normal mid-cycle upsurge of gonadotrophins in the plasma and urine. Progestogens given alone do not usually suppress ovulation. It is the oestrogen content of the combined oestrogen-progestogen oral contraceptives which mainly determines their anti-ovulatory effect.

### *Androgens*

Any androgen given in a sufficient dose inhibits ovulation, mainly by direct inhibition of the ovarian follicles.

### *Danazol*

This drug has antigonadotrophic effects that suppress the mid-cycle surge of gonadotrophins. Most women become amenorrhoeic within 6-8 weeks of treatment.

### *Analogues of Hypothalamic Releasing Factors*

Ovulation can be inhibited by GnRH agonist treatment.



## PUBERTY AND ADOLESCENCE

### Definition and Description

Adolescence (Latin: *adolescere* = to grow) is the period of life during which the carefree child becomes the responsible adult. The period varies in duration from one individual to another and is difficult to define. A modern description of the adolescent is the 'teenager'.

*Puberty* (Latin: *pubertas* –adulthood) is the state of becoming functionally capable of procreation. This is usually accepted as occurring at the age of 12 years in girls and 14 years in boys, but full reproductive capacity is not usually attained until later. Puberty is characterised by physical sexual differentiation and by the onset of activity of the sex organs (*see* Fig. 6.1 and Table 6.1).

Puberty is really the first part of adolescence, the remainder being concerned with the mental and emotional adaptation to sexual function and with the development of full maturity. The *menarche* (Greek: month + origin) is the onset of menstruation and is merely one manifestation of puberty.

During childhood the anterior pituitary is concerned mostly with physical growth. It is capable of gonadotrophic activity but is inhibited by the hypothalamus until the higher centres of the brain are more mature. At puberty, as a result of the increased secretion of releasing factors by the hypothalamus, and the increased responsiveness of the pituitary gland to these factors, all activities are increased. This is manifested by a sudden spurt in stature just before or after the menarche (GH effect); by enlargement of the thyroid (TSH effect); by increased adrenal cortical activity (ACTH effect); by skin pigmentation (MSH effect); and by the onset of ovarian activity (gonadotrophin effect). The cyclical production of gonadotrophins and oestrogens in amounts approaching those found in the adult is often demonstrable by the age of 10 years. The secretion of oestrogen by the ovaries and of androgens by the adrenals induces epiphyseal closure, and skeletal growth then ceases.

Nevertheless, some sexual differentiation occurs in childhood. The nipples are rather more obvious in the female than the male by the age of 3 years, and there is a tendency to plumpness and roundness of the limbs at 6-8 years. The pelvis widens between the ages of 7 and 11 years. Definite signs of puberty are usually present by

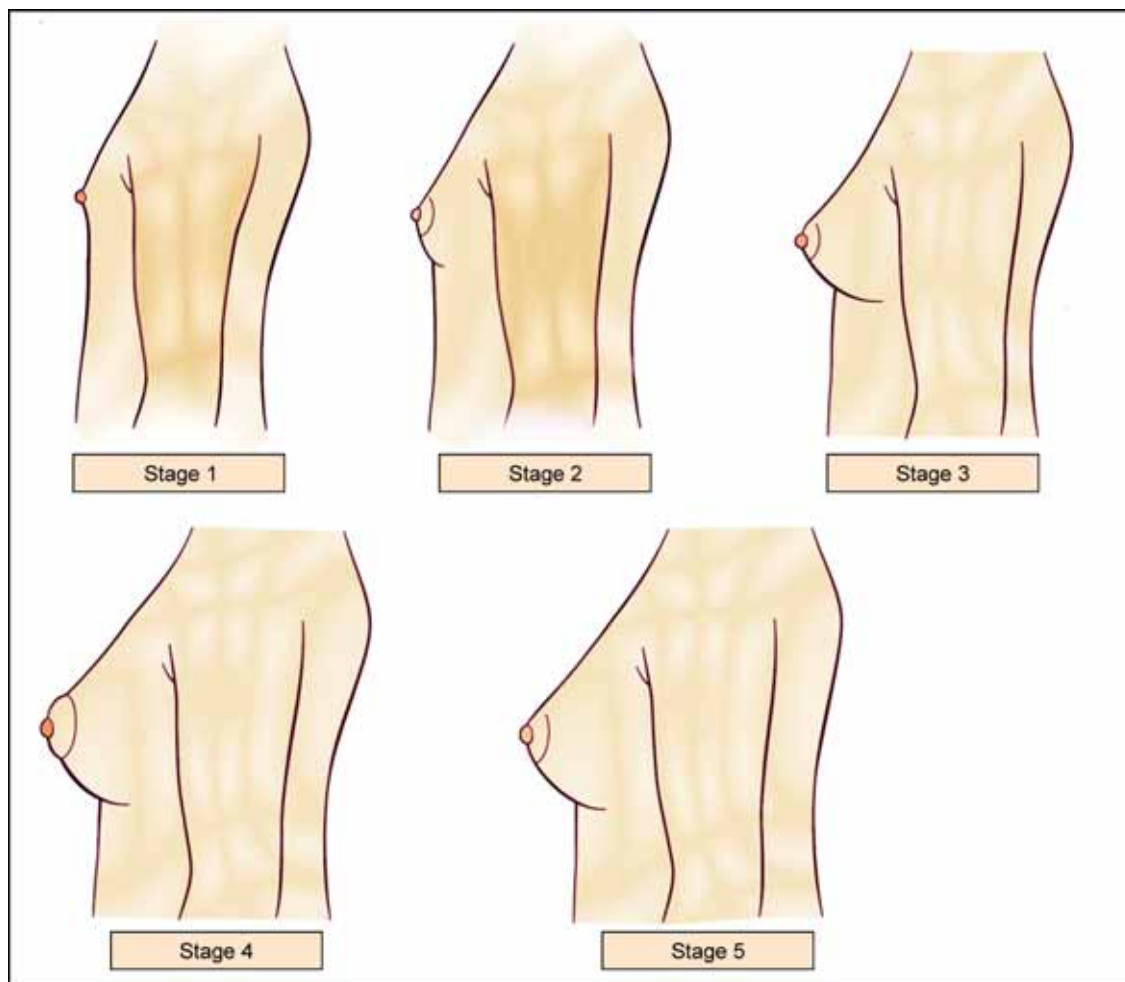


Fig. 6.1: Development of the female breast

Table 6.1: Tanner staging of development of secondary sex characteristics

Stage	Breast	Pubic hair
1.	Elevation of papilla	No pubic hair (prepubertal)
2.	Elevation of breast and papilla as a small mound, increased areolar diameter (median age 9.8 years)	Sparse, long pigmented hair mainly along labia majora (median age 10.5 years)
3.	Further enlargement without separation of breast and areola (median age 11.2 years)	Dark, coarse, curled hair sparsely spread over mons (median age 11.4 years)
4.	Secondary mound of areola and papilla above breast (see Fig. 6.1) (median age 12.1 years)	Adult-type, abundant hair, but limited to the mons (median age 12.0 years)
5.	Recession of areola to contour of breast (median age 14.6 years)	Adult type spread in quantity and distribution (median age 13.6 years)

Reproduced with permission from Speroff L. *et al.*, *Clinical Gynaecologic Endocrinology and Infertility* (ed. Mitchell C), Lippincott Williams and Wilkins, 1999.

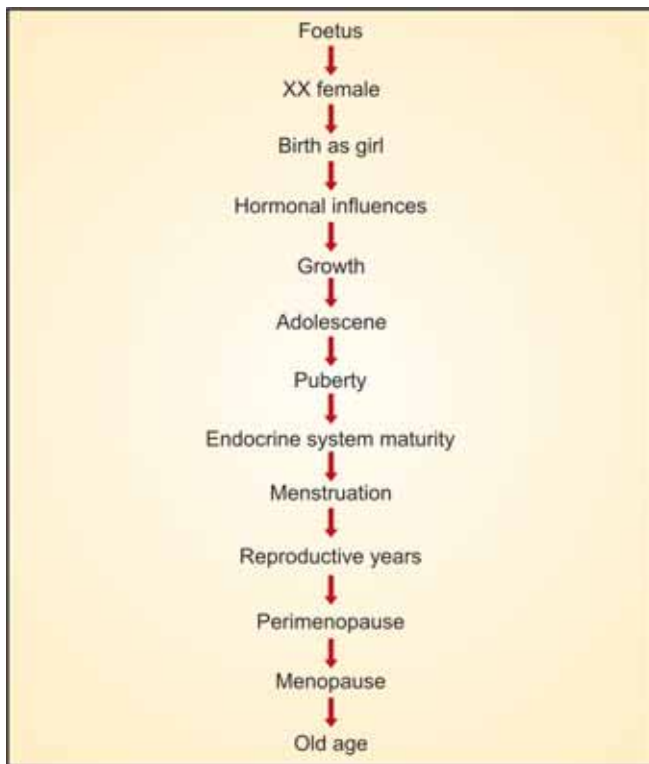
the age of 9 or 10 years when the breasts develop a 'bud' (*thelarche*, Fig. 6.2A), and soon afterwards they become generally enlarged. By this time hair begins to grow on the body, appearing first on the mons veneris (adrenarche). Meanwhile body contours change by the deposition of fat, the growth spurt occurs and there is some evidence of skin pigmentation, notably on the vulva but sometimes around the eyes, mouth and nipples, and on the abdominal wall in the form of a linea nigra. Some development of the breasts and pubic hair usually precedes the onset of menstruation, the average interval being 2 years. Axillary hair appears later, often after the menarche. Hence, the adolescence starts with *thelarche* (development of breast buds), followed by *pubarche* (development of pubic hair), *adrenarche* (development of axillar hair) and *menarche* (the first menstruation) (Flow chart 6.1).

The first menstrual period usually occurs between the ages of 10 and 16 years, the average being 13.5 years in India, 13.0 years in Western Europe and 12.5 years in North America. The age of the menarche varies to some extent with family, race, social class, family size, birth

order, environment, diet and general health, but not with climate. Menstruation tends to occur earlier in the higher social classes and in urban surroundings; this probably reflects general health. The age of the menarche, and of maturity in general, is falling. Among Caucasian races at least, girls of 14 and 15 years are now as physically and sexually developed as their mothers were at the age of 16 years. In England and Wales, Western and Northern Europe and in North America the mean age of the menarche dropped from 17 to 13 years during the 100 years up to 1960, decreasing at the rate of 4 months every 10 years. Similar trends were, and are being, seen in all countries and are variously credited to better nutrition, freedom from disease and increased outbreeding which provides hybrid vigour. However, after 1965 (in girls born from 1946 onwards), the menarchal age ceased to fall in Britain, North America and Western Europe and is now static at the levels indicated above. Whether this is a temporary or permanent stabilisation remains to be seen.

During the 2 years before the menarche the development of the genital tract proceeds apace. The menstrual flow itself is often preceded by mucoid vaginal discharge, and by periodic hypogastric pain caused possibly by uterine contractions. Rarely ovulation and even conception can precede the menarche. The phase of active physical growth makes the girl temporarily lanky and awkward in her movements. Thereafter, the figure becomes fuller and feminine and the shrill voice of the child changes to the slightly deeper and more melodious tone of the adult. Girls reach peak height velocity early in puberty before menarche. As a consequence, they have limited growth potential after menarche whereas, boys reach peak height velocity about 2 years later than girls. Boys grow an average of 28 cm during the growth spurt, in comparison to a mean of 25 cm for girls. The control of this is connected to the hormonal control of the pubertal growth spurt. Growth hormone, insulin-like growth factor 1 (IGF-1), and gonadal steroids play major roles. During puberty the long bones in the body lengthen, and the epiphyses ultimately close. The bone or skeletal age of any individual can be estimated closely by comparing X-rays documenting the development of bones in the nondominant hand (most commonly), knee, or elbow to standards of maturation for the normal population. Another practical clinical approach to predicting adult height uses midparental height. Several changes in body composition also occur during pubertal

Flow chart 6.1: Phases of female development



development. The changes in body contour in girls, with accumulation of fat at the thighs, hips, and buttocks, occur during the pubertal growth spurt. Voice and other changes also are associated with the changes in body composition

During puberty and adolescence the psychological changes are profound. The happy-go-lucky tomboy changes into a self-conscious girl who is interested in her appearance, may be moody and secretive, and is often imaginative and curious. She begins to feel that she is grown up, finds it more difficult to obey orders, and looks for independence. Her *confidante* becomes another girl rather than her mother. The sex urge becomes manifest and is often homosexual at first being evidenced by an unreasonable 'passion' for a particular older girl or woman. This phase is usually followed, sooner or later, by heterosexual impulses and activities.

Temporary enlargement of the thyroid at puberty has already been mentioned. Acne of the face and back is often a nuisance for 1 or 2 years after the menarche; it is mainly the result of increased androgen secretion by the adrenal which is also manifested by an increased excretion of 17-ketosteroids in the urine. Indeed, many of the manifestations of puberty (for example, the growth of pubic and axillary hair) are the result of adrenal rather than of ovarian activity. Vasomotor instability is revealed by a tendency to blush at the slightest provocation.

### Management of Adolescence; Sex Education

The problem of adolescence is that the girl regards herself as grown up and adult whereas physical and emotional maturity are not achieved until several years after the menarche. The management of the adolescent is difficult and is directed to ensuring that a balanced adult emerges from the testing period. The girl should not be teased or ridiculed but her move towards independence respected and controlled within limits. Affection and trust should take the place of orders. She should be encouraged to be continually occupied in either work or healthy recreation within the limits of her physical strength. Above all, her parents must be ready to accept and even encourage the disappearance of childhood ties and dependence. Failure to do so means that their daughter will never adequately fulfil her intended roles as a wife and a mother. It should be recognised that some girls are extremely embarrassed by changes in figure, especially by the development of the breasts, which they may attempt to hide by adopting a round-shouldered posture. Such girls are sensitive to

comment and are helped by the provision of loose-fitting upper garments.

On the other hand, there are many early 'teenagers' who worry because their bust development seems to them late or poor, and who accept the menarche and its accompaniments with pride. These are the ones who have been well primed in what to expect. The onset of menstruation in a girl who is uninformed arouses emotions of fear and shame, and can give her a psychological shock from which she never fully recovers. Failure of the adolescent to realise the implications and potential dangers of sex can lead to tragedy. Sex education should come naturally and piecemeal throughout childhood. Even infants are curious about their genitalia and their curiosity should be satisfied. Children inevitably ask questions and these should be answered simply but truthfully as they arise. Indeed, sex instruction should be merely part of the general education of the child, acquired from day to day in the course of family conversation, and becoming more detailed with the passing of time.

In today's world, the very real risks of unwanted teenage pregnancy and sexually transmitted diseases cannot be ignored. The progressively decreasing age of menarche has resulted in the first, the increasing permissiveness of society in the second. Today's adolescent needs to be armed with sufficient information to be protected against the hazards of HIV infection, in addition to other reproductive tract infections and to avoid the psychological and physical consequences of unwanted illegitimate pregnancy.

### Abnormalities of Puberty and Adolescence

#### *Obesity*

Adolescence is sometimes accompanied by a rapid increase in weight and the development of 'puppy fat'. This can be associated with the formation of *striae* on the breasts, flanks, buttocks and upper arms which are reddish-purple at first but later fade to silver. The cause is a weakening of the elastic tissue by an increased production of adrenal corticoids together with stretching of the skin by subcutaneous fat. Some of these girls may have an underlying problem such as hypothyroidism or polycystic ovaries. Obesity in children and adolescents, irrespective of the underlying metabolic processes of the individual, is nearly always associated with overeating, or with eating predominantly carbohydrates. This is true

no matter what the protesting parent may say. Adolescent obesity of a minor degree tends to disappear by the age of 20 years if the appetite is reasonably curbed. Obesity of a gross degree, however, requires strict dietetic control (1000 kcal in 24 hours), lest it persist and progress to prejudice the girl's future menstrual and reproductive functions, as well as her health in general.

There may be variation in the age of menarche and the obesity of the girl. Typically, the age of menarche is earlier than average in children with moderate obesity (up to 30% above normal weight for age), whereas delayed menarche is common in those with severe malnutrition.

Early in puberty, there is increased sensitivity of LH to GnRH. Gonadotropins are always secreted in an episodic or pulsatile fashion, even before puberty, the pulsatile secretion of gonadotropins is more easily documented as puberty progresses and basal levels increase. Appearance of the axillary and pubic hair is because of increased adrenal androgen secretion. Progressive increases in circulating levels of the major adrenal androgens, dehydroepiandrosterone (DHEA)

and its sulfate (DHEAS) accelerate at 7 to 8 years of age, and continue until 13 to 15 years of age. The accelerated increases in adrenal androgens begin about 2 years before the increases in gonadotropin and gonadal sex steroid secretion. Estrone, which is secreted in part by the ovaries and arises in part from extraglandular conversion of estradiol and androstenedione, also increases early in puberty but plateaus by midpuberty. Thus, the ratio of estrone to estradiol decreases throughout puberty, and this indicates that ovarian production of estradiol becomes increasingly important and peripheral conversion of androgens to estrone becomes less important during maturation.

*Menstrual Disorders*

See below and Chapters 37 and 38.

*Delayed Puberty*

The term delayed puberty is used when secondary sex characters do not develop and when menstruation does not begin before the age of 16 years (Figs 6.2A and B). If this arbitrary figure is accepted, one in every 100 girls



**Figs 6.2A and B:** Delayed puberty. Girl, aged 17 years, complaining of primary amenorrhoea. (A) Breast development has commenced and is characterised by the areolar bud ordinarily seen in a girl aged 9-12 years. Axillary hair has not yet appeared, (B) The labia majora are poorly developed and pubic hair is scanty. Investigation, which did not include sex chromosome analysis, revealed no abnormality and no treatment was given. Maturation proceeded spontaneously and menstruation commenced 2 years later

who subsequently prove to be normal and fertile has delayed puberty. Delayed puberty could be defined as girls who fail to develop any secondary sex characteristics by age 13, have not had menarche by age 16, or have not attained menarche 5 or more years since the onset of pubertal development.

The causes and management of delayed puberty are those of primary amenorrhoea (*see* Chapter 37).

### Precocious Puberty

Precocious puberty is defined as the onset of menstruation, accompanied by other evidence of puberty such as the development of breasts and pubic hair before the age of 8 years, taking mean  $\pm 2$  standard deviations as encompassing the normal range. Physical development is also precocious in some cases but epiphyseal closure is likely to occur early so the individual may ultimately be short in stature. Mental development may be retarded or advanced and precocious girls commonly show abnormal electroencephalographic patterns. However, reproductive life is normal and menopause also occurs normally.

#### Classification of Female Precocious Puberty

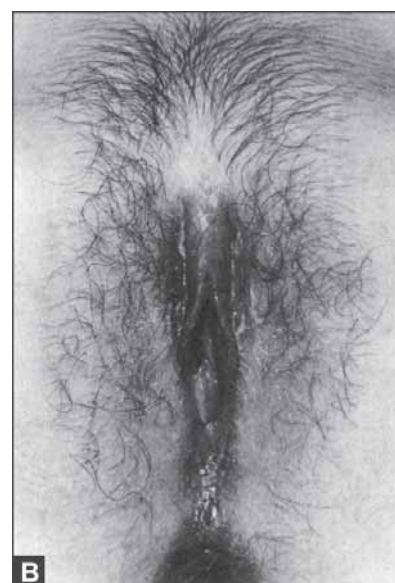
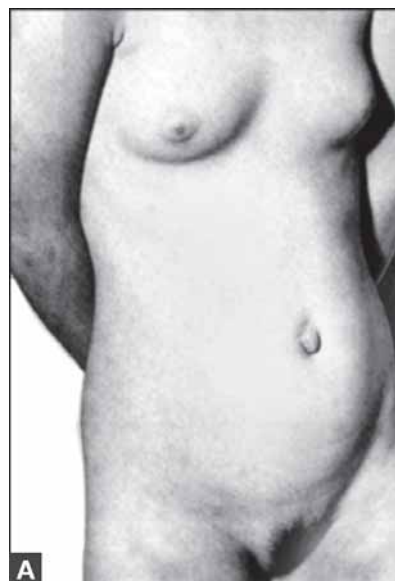
- I. Complete isosexual precocity (true precocious puberty: gonadotropin dependent)
  - A. Idiopathic
  - B. CNS lesions: Hamartomas, Craniopharyngioma, etc
  - C. Primary hypothyroidism
  - D. Post-treatment for CAH
- II. Incomplete isosexual precocity (GnRH independent)
  - A. Isolated precocious thelarche
  - B. Isolated precocious menarche
  - C. Estrogen-secreting tumours of the ovary or adrenals in girls
  - D. Ovarian cysts
  - E. McCune-Albright syndrome
  - F. Peutz-Jeghers syndrome
  - G. Iatrogenic
- III. (Isolated virilisation)
  - A. Isolated precocious adrenarche
  - B. Congenital adrenal hyperplasia
  - C. Androgen-secreting ovarian or adrenal neoplasm
  - D. Iatrogenic.

### Causes

Precocious puberty may be GnRH- and gonado-trophin-dependent or may be GnRH-independent being caused by the peripheral secretion of sex steroids.

### Constitutional

In 80 per cent of cases no organic abnormality is found and the precocity appears to be merely an individual characteristic (Figs 6.3A and B). Hypothalamic, pituitary, adrenal and ovarian functions mature early and regular



**Figs 6.3A and B:** Precocious puberty. Child, aged 3 years 11 months, who had been menstruating for 18 months. The breasts, pubic hair and the vulva are well developed. No abnormality was found on investigation and the precocity was labelled 'constitutional', but the after history of this case is unknown so a lesion in the hypothalamic-pituitary system is not excluded (*see text*)

menstruation can occur even at the age of 2 or 3 years. Gonadotrophins and gonadal hormones are excreted in adult quantities. Thus these are cases of GnRH-dependent or true precocious puberty. A baby aged only 9 months (bone age = 5 years) has been recorded as suffering from constitutionally precocious puberty. In many cases, however, subsequent development reveals a previously unrecognised lesion in the hypothalamus-pituitary region. Thus, an oft-quoted example of constitutional precocity is Lina Medina of Peru who not only had an early menarche but was delivered of a child at the age of 5 years 8 months. In fact, follow-up studies some years later showed that this girl suffered from Albright syndrome.

One form of constitutional precocity runs in families and usually occurs around 8 years of age. In these patients the normal sequence of pubertal events described above may not be followed.

Sexual precocity has been seen in a few cases of primary hypothyroidism, perhaps by stimulation of FSH receptors by the increased levels of TSH. These patients have galactorrhoea in addition to other clinical features. Though uncommon, this should be excluded in all cases of true isosexual precocity. In any case constitutional precocity is a diagnosis of exclusion and it may take many years for lesions to manifest.

*Disease in the Regions of the Midbrain, Hypothalamus and Pituitary*

A variety of lesions in the regions of the midbrain, hypothalamus and pituitary which result in precocious puberty are as follows:

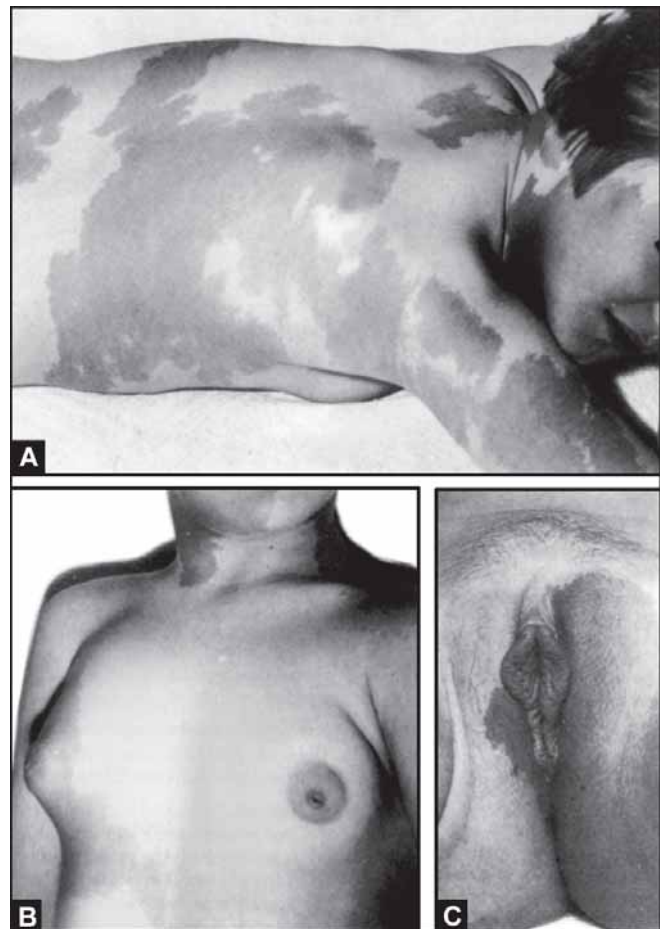
- Congenital defects, e.g. hamartoma, hydrocephalus, craniopharyngioma
- Tumours, e.g. astrocytoma, glioma, neurofibroma, ependymoma and suprasellar tumours
- Non-tumour conditions, e.g. encephalitis, meningitis, von Recklinghausen's disease, Albright syndrome
- Cranial trauma and abnormal skull development due to rickets.

The pathophysiology is unclear but most lesions are associated with increased intracranial pressure and are located in the region of the hypothalamus. This stimulates the output of hypothalamic releasing factors and/or gonadotrophins. One example is the McCune-Albright syndrome in which early puberty is associated with polyostotic fibrous dysplasia, fractures of bones and patchy yellow-brown pigmentation of the skin (café au

lait spots) (Figs 6.4A to C). The hypothalamus and pituitary are disturbed by sclerotic overgrowth at the base of the skull.

*Oestrogenic Tumours of the Ovary*

Precocious puberty is seen in patients with oestrogen-producing ovarian tumours such as granulosa and theca cell tumours. However malignant teratomas, ovarian cysts and cystadenomas have also been reported as causes of precocious puberty. Menstruation is not regular in time or duration and is not accompanied by ovulation. The breasts are enlarged but there is little body hair because adrenal function is not mature. The excretion of oestrogens is high and that of gonadotrophins low, although exceptions to this rule have been reported.



**Figs 6.4A to C:** Precocious puberty as part of Albright syndrome. Girl, aged 7 years, with well-developed breasts and vulva who had been menstruating for 2 years. She had suffered many fractures and both legs were in plaster at the time of photography. The patchy yellow-brown pigmentation is a typical feature (see text)

*Adrenal Cortical Tumours*

The precocity in these cases may be isosexual but is usually heterosexual; females show precocious virilism.

*Androgenic Tumours of Ovary*

Gonadoblastomas and lipid cell tumours are associated with heterosexual precocity.

*Ectopic Gonadotrophin Production*

This is very rarely seen in hepatoblastoma, dysgerminoma and choriocarcinoma which secrete hCG.

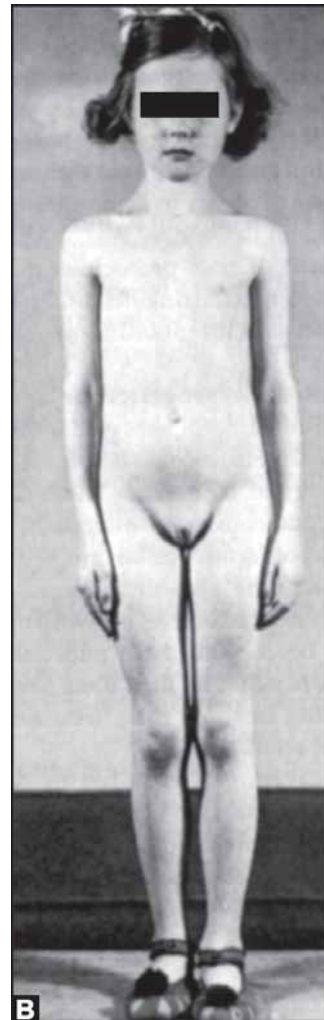
**Management**

Children presenting with vaginal bleeding before the age of 8 years should be examined for evidence of secondary sex characters. If these are not present, the bleeding is

probably not menstrual and a local organic cause in the uterus or vagina should be looked for (Figs 6.5A and B).

If secondary sex characters are present, then examination and special investigations should be done to exclude an intracranial, ovarian or adrenal lesion. The demonstration of pubertal or abnormal levels of plasma gonadotrophins in the plasma indicates that the anterior pituitary is showing precocious activity. Measurements of serum oestradiol, progesterone, 17-hydroxyprogesterone, testosterone and dehydroepiandrosterone sulphate (DHEAS), as indicated by the history and physical findings, along with basal FSH and LH levels are helpful. Any abnormality on neurological examination, head CT scan or MRI suggests a cerebral cause.

Then management depends on whether is its gonadotropin dependent (in which case it is almost



**Figs 6.5A and B:** Alleged precocious puberty. Child, aged 7 years, who had bled vaginally on two occasions. There is no development of the breasts, pubic hair or vulva and this indicates that the bleeding was not menstrual or the result of hormone stimulation. It was decided that it was caused by local interference of some kind and it did not recur. A normal menstrual cycle, accompanied by physical maturation, began 6 years later. At a later stage in life this patient was seen again and was then found to have a uterus didelphys and septate vagina. So the bleeding in childhood was probably caused by injury to the lower border of the septum inflicted by the patient herself. The photograph of the vulva shows what looks like a prominent clitoris. This is usual in childhood and is explained by poor development of the labia



invariably of central origin) or gonadotropin independent (of peripheral origin). The evaluation of precocious puberty is as follows:

The first test should be the measurement of basal gonadotropin levels.

Thyroid function should also be evaluated to rule out primary hypothyroidism as the cause of precocious development.

High levels of LH (which really may be human chorionic gonadotropin detected because of cross-reactivity with LH in immunoassays) suggest a gonadotropin-producing neoplasm, most often a pinealoma (ectopic germinoma).

Increased oestradiol levels suggest an oestrogen-secreting neoplasm, probably of ovarian origin.

Increased testosterone levels suggest an androgen-producing neoplasm of the ovary or the adrenal gland. Such neoplasms may be palpable on abdominal or rectal examination. Increased  $17\alpha$ -hydroxyprogesterone levels are diagnostic of 21-hydroxylase deficiency (i.e., congenital adrenal hyperplasia [CAH]). Dehydroepiandrosterone sulfate levels are elevated in various forms of CAH as well.

Bone age should always be assessed in evaluating an individual with sexual precocity. Then management with GnRH agonist therapy initially increases circulating gonadotropin and oestradiol concentrations for short periods of time. Chronic therapy is associated with suppression of pulsatile gonadotropin secretion and a blockade to the LH response of endogenous GnRH. Suppression is best monitored with GnRH challenge tests. Additionally, measurement of serum oestradiol (if elevated on prior analysis), height, bone age, and assessment of secondary sexual characteristics may be helpful. Evaluation of ovarian morphology and uterine size by pelvic ultrasonography may, in some cases, provide additional evidence of such suppression. The various effects like cessation of menses, regression in physical pubertal signs (i.e., breast size and pubic hair), and a diminution of uterine and ovarian size usually occur within the first six months of therapy.

If these are normal, it is most likely to be idiopathic sexual precocity. If a feminising adrenal tumour is suspected (with elevated serum DHEAS and oestradiol and low gonadotrophins), abdominal and pelvic ultrasound or MRI can be done. Ovarian tumours are also associated with elevated oestradiol and low gonadotrophins and can be detected by imaging. Skeletal survey for bone age shows accelerated maturation (breast development with bone age 11 and menarche with bone age 13). Virilising ovarian tumours may result in elevated serum DHEAS or androstenedione levels. Ovarian and adrenal tumours should be surgically resected.

Precocious puberty with delayed bone age suggests primary hypothyroidism. Serum TSH is increased, serum T4 is low, galactorrhoea may be present along with increased serum prolactin. Serum gonadotrophins are in the pubertal range. The sella may be widened on imaging. All values return to normal with treatment.

Patients with Albright syndrome may have a very variable presentation and sometimes a technetium-99 bone scan may be necessary to demonstrate areas of fibrous dysplasia in the bones.

The management of true precocious puberty requires attention to maximising height, arresting further maturation and attenuating precocious features.

In the past, medroxyprogesterone acetate, cyproterone acetate and danazol were used with some success. The use of GnRH analogues has significantly improved the results of treatment. These can be administered subcutaneously or intranasally, daily or in long-acting depot forms. The last are obviously the most preferred. The goal of therapy is to maintain the serum oestradiol level below 10 pg/ml. Treatment has to be continued till pubertal and chronological ages match. The final bone height is increased depending on how early treatment is instituted.

Prolonged observation is required to detect evidence of underlying disease in the pituitary, ovary or adrenal gland which may appear later.

Parents should be warned to guard the precocious child from possible sexual assault.

# CHAPTER 7

## Conception

Fertilisation of the Ovum	120
Early Development of the Ovum	123
Implantation of the Ovum into the Uterus	123
Formation of Foetus and Membranes	125
Hormonal Control of Early Pregnancy	128

### FERTILISATION OF THE OVUM

Pregnancy results when the liberated ripe ovum is fertilised by a spermatozoon. The opportunity for their meeting is provided by the deposition of semen in the upper vagina and on the external os during coitus. Even if spermatozoa are only deposited on the vulva they can sometimes make their way up the vagina to the cervix. This explains the occasional pregnancy in apparent virgins and also failures of coitus interruptus as a method of contraception.

Semen consists of mature spermatozoa (and a variable number of immature forms) suspended in a creamy viscous fluid secreted by the seminal vesicles and prostate. When spermatozoa leave the testis they have undergone the first maturation division with reduction of the number of chromosomes from 46 to 23. But they are neither fully mature nor capable of fertilisation. It takes them about 72 days from initiation of spermatogenesis to reach the caudal end of the epididymis and they do not become motile until they mix with seminal fluid immediately before ejaculation. It has long been said that spermatozoa are not stored in the seminal vesicles, but they must be because they appear in seminal fluid for 2-3 months after division of the vasa as in vasectomy.

Seminal fluid becomes clear and watery within 30 minutes of ejaculation; this liquefaction being brought about by prostatic secretion. The fluid contains fructose, the amount of which decreases rapidly after ejaculation as the spermatozoa use it for a source of energy.

Once deposited in the vagina, spermatozoa find themselves in a hostile acid medium from which they must escape quickly if they are to survive. Seminal fluid itself is alkaline with a pH of 7.05-7.41, rising to 7.5-8.0 on standing *in vitro*. When mixed with vaginal secretion the pH of the seminal pool is 6.2, and may be only 5.5 if the alkaline contributions from the cervix and from Bartholin's glands are limited. All spermatozoa remaining in the vagina for 2 hours or longer are killed, and it is probable that only those which can enter the alkaline cervical canal within a few minutes retain their fertilising power. They enter the cervix under their own powers

of propulsion, being directed by chemotaxis (acid repels and alkali attracts). They invade the mucus plug in the cervical canal which, at the time of ovulation, is arranged to form micro-channels to allow easier penetration. Once through the cervix, spermatozoa ascend rapidly; so rapidly that it is believed that they are moved by contractions of the uterus and tubes in addition to their own power. These contractions may be stimulated by prostaglandins present in semen. The chief function of its flagellum may be to allow the spermatozoon to penetrate the corona radiata and the capsule of the ovum.

The time taken for spermatozoa to travel from the vagina to the tubes may be as short as 5 minutes. Many are lost on the way, the semen being expelled from the introitus, the sperm digested by vaginal enzymes or phagocytosed by the epithelial cells of the genital tract. Those that reach the tube travel against the ciliary current and some find their way into the peritoneal cavity (Fig. 7.1). Of an average of 200-300 million

spermatozoa deposited in the vagina, fewer than 200 finally reach the egg. Until they enter the female genital tract, spermatozoa do not possess the capacity to penetrate the zona pellucida and to fertilise the ovum. 'Capacitation' is only acquired after they have been in the cervix, uterus and tubes for 2-4 hours.

The seminal plasma factors coating the surface are removed and the surface charge modified when the capacitated sperm interact with the follicular fluid, the sperm head undergoes the acrosome reaction, allowing the release of several enzymes including hyaluronidase, corona-dispersing enzymes and acrosin. The sperm motility also increases remarkably. All these changes are critical for zona penetration.

*In vitro*, the acrosome reaction can be induced by human follicular fluid and the zona pellucida proteins of the oocyte. *In vitro* capacitation can be brought about in a culture medium which is a balanced salt solution containing lactate, pyruvate and glucose for energy and

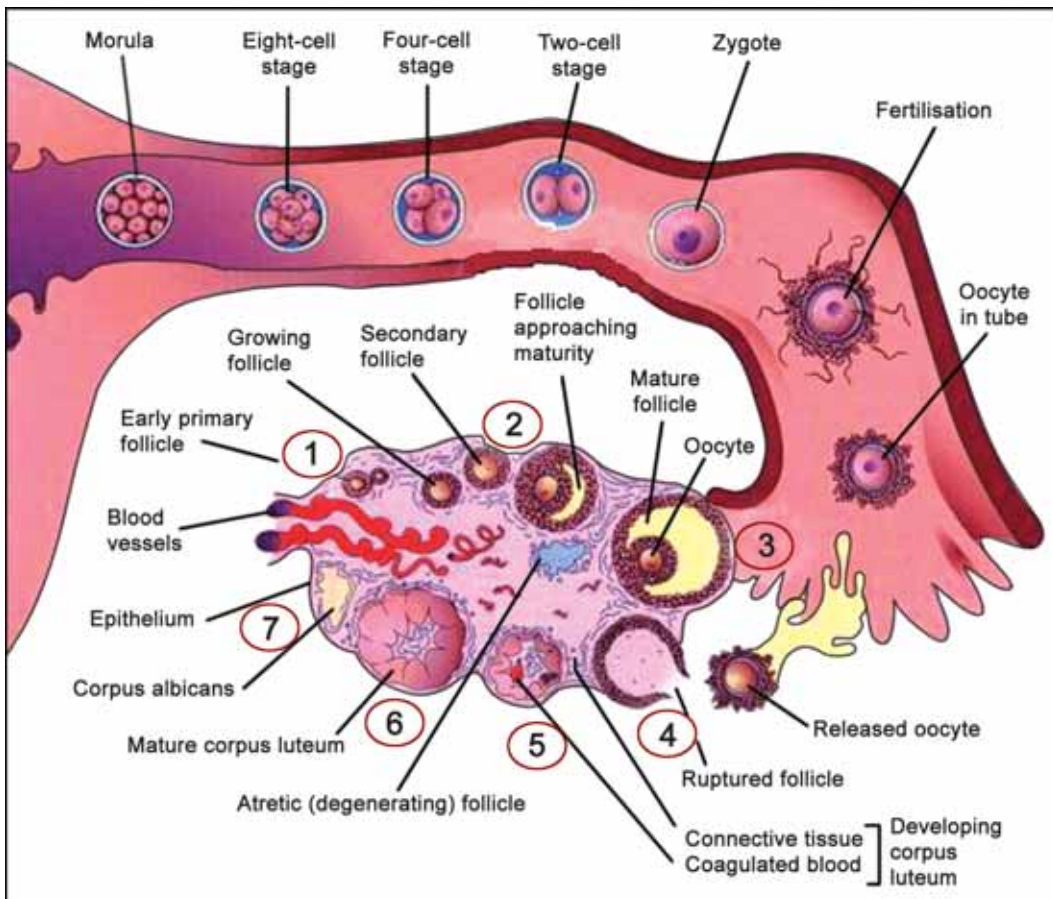


Fig. 7.1: Diagrammatic representation of ovulation, maturation of the ovum and fertilisation

albumin. This is used in assisted reproduction technology.

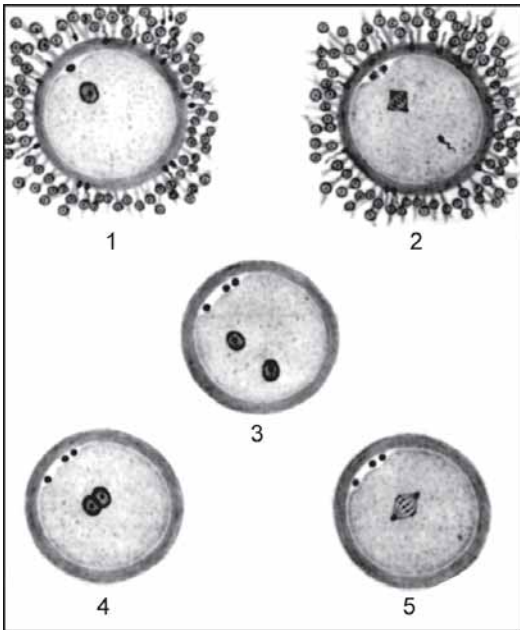
An ovum leaves the ovary having already undergone the first maturation (reduction) division and is picked up by the fimbria of the fallopian tube. In the ampulla of the tube, the gamete, still enclosed by the corona radiata, is approached by numerous spermatozoa some of which probably have the function of softening or preparing the envelope of the ovum by releasing hyaluronidase.

Ultimately, a single spermatozoon penetrates the ovum and then loses its tail and body. The pronucleus, contained in its head, does not actually fuse with the pronucleus of the ovum. As they complete their second maturation divisions, each gamete contributes its chromosomes to form a single nucleus containing 46 chromosomes. Thereafter, the fertilised ovum begins a

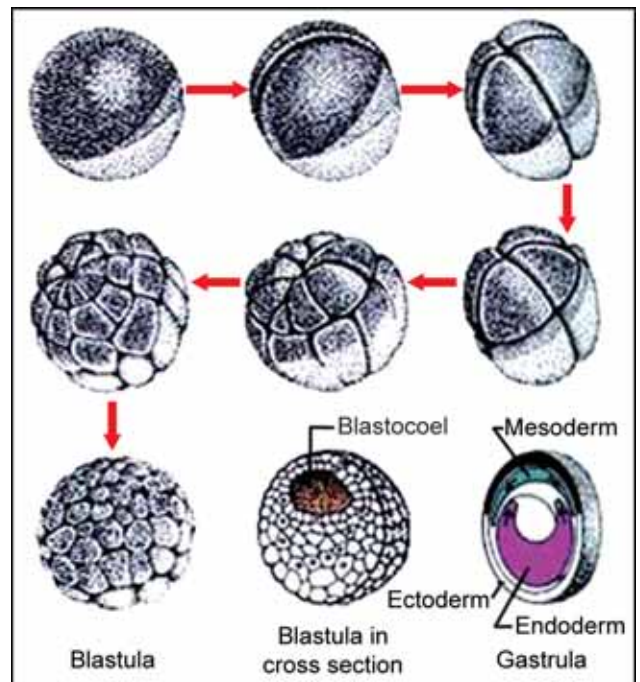
series of cell divisions but, for the first 7 days, does not increase in overall size (Figs 7.2 and 7.3).

How long can human spermatozoa survive in the female genital tract? It is true that spermatozoa have been found to retain motility in the cervical canal and uterus for 5-7 days, and have been found in the tube 60 hours after coitus, but this does not mean that they have the power to fertilise. Indeed, the evidence shows that spermatozoa do not retain this property for longer than 48 hours, and probably not for longer than 24 hours, after being implanted in the vagina. The ripe ovum can survive in a fertilisable form for only 24 hours, and probably only for 8-12 hours after it leaves the ovary.

Conception is therefore extremely unlikely unless coitus takes place during the 2 days before, or immediately after, ovulation. This is the basis for the *fertile period* of each monthly cycle. If ovulation always occurred on the fourteenth day of the cycle, conception could only result from coitus on the twelfth, thirteenth, fourteenth and fifteenth days. In fact, there is some



**Fig. 7.2:** Maturation and fertilisation of the ovum while still surrounded by the corona radiata. These events take place in the tube and are illustrated as follows. (1) Prior to ovulation the first (reduction) division has taken place to give rise to a polar body shown as a black dot to the side of the ovum itself. (2) The second division occurs, or is completed, after the spermatozoon penetrates the ovum; the polar body also divides so that the ultimate result is three polar bodies. (3) The male and female pronuclei approach each other to contribute chromosomes which link together to form one nucleus; the pronucleus of the spermatozoon is smaller than that of the ovum but, for clarity, is here shown of similar size. (4) Fusion almost complete. (5) The first division after fertilisation to produce a 2-cell ovum



**Fig. 7.3:** The development of the fertilised ovum during the first 7 days. (1) Morula stage. (2) Blastocyst stage. During this process, and to permit its transport along the tube, the ovum does not increase in size much. The diameter of the blastocyst is only 0.13 mm, that of the ovum immediately after fertilisation being 0.1 mm. The zona pellucida persists until the blastocyst embeds in the endometrium

variability in the time of ovulation so allowance is made for this and the fertile period in a woman with a 28-day cycle occupies the seventh to nineteenth days. The other days in the cycle constitute the *safe period* but it should be recognised that it is relatively rather than absolutely safe. Indeed, pregnancy is recorded following coitus on any day of the cycle, even during menstruation, but this is rare and is explained by some unusual irregularity in the time of ovulation rather than by longevity on the part of spermatozoa.

### EARLY DEVELOPMENT OF THE OVUM

The first division of the ovum into two cells occurs within 24-30 hours of fertilisation and thereafter each cell divides again and again to form a *morula*, a clump of cells 0.13 mm in diameter, by the third or fourth day (Fig. 7.3, 7.12 to 7.17). The morula, still covered by the zona pellucida, next becomes cystic as a result of fluid being either secreted by its own cells or absorbed from the genital tract (Figs 7.3 and 7.4). It is moved along the fallopian tube by the ciliary current and by peristalsis, being nourished temporarily by the cells of the corona radiata and by the secretions of the endosalpinx. In approximately 4 days it reaches the uterine cavity where it lies free for another 2 or 3 days during which it is

supported by the secretions of progesterational endometrium. This *blastocyst*, present by the seventh day, consists of a single layer of cells surrounding the contained fluid, with a collection of cells forming a solid area on the inner aspect of the wall at one point. This is the *inner cell mass* from which the foetus is formed. The cyst wall of flattened cells is the *trophoblast* which soon becomes differentiated into two layers: an inner one of cuboidal cells — the *cytotrophoblast*; and an outer one — the *syncytiotrophoblast* (Figs 7.4 and 7.5). The latter consists of irregular masses of protoplasm with multiple nuclei and few cell walls. It is probably developed from the cytotrophoblast and its formation from this source is continued throughout pregnancy. The function of the trophoblast is to attach the ovum to the wall of the uterus and thereafter to nourish it.

### IMPLANTATION OF THE OVUM INTO THE UTERUS

About the seventh day the blastocyst adheres itself to the wall of the uterus, normally in the upper part for which it has a special predilection, and then burrows into the endometrium (invasion). At this time it loses its covering, the zona pellucida. The site of entry is quickly sealed (Figs 7.1 and 7.6). The invasive power is provided

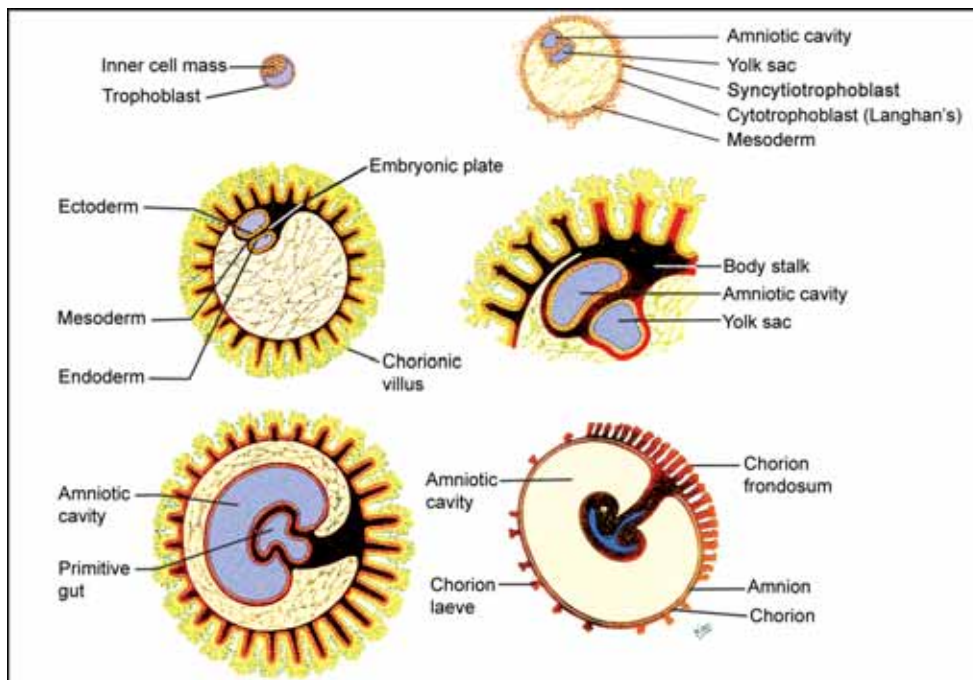
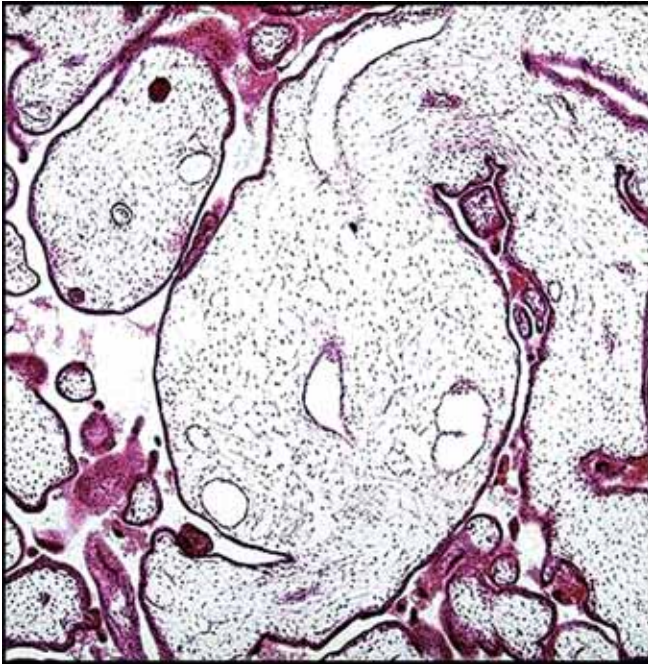


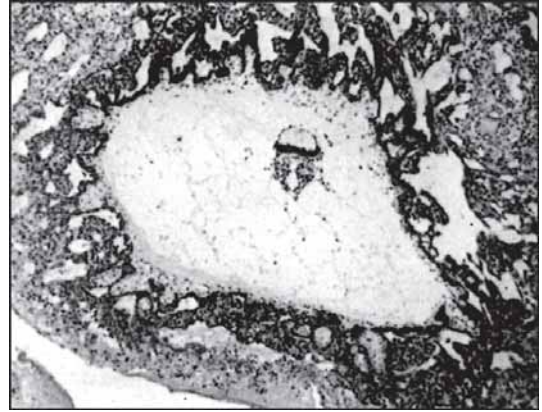
Fig. 7.4: The development of the early embryo and its membranes



**Fig. 7.5:** First trimester placental villi. The villous stroma is immature and contains blood vessels in which nucleated foetal erythrocytes can be seen. The trophoblast around the villi forms an outer syncytiotrophoblastic layer and an inner layer of cytotrophoblast. (Photomicrograph x600)

by enzymes of the syncytium and related proteins, e.g. implantation-initiating factor, fibronectin and blastokinin, and the endometrium, already sensitised by progesterone, reacts by a strong decidual change. Decidual reaction is also seen to a limited extent on the pelvic peritoneum and on the surface of the ovary. Decidual reaction is also sometimes seen in cervical tissues, including cervical polypi. Occasionally the peritoneal reaction is excessive and causes the condition of *deciduosis peritonei*. In this, greyish-white nodules of decidua, 2-10 mm in diameter, are found scattered on the surface of the uterus, tubes, ovaries, broad ligaments, mesocolon, omentum and even the diaphragm. These can bleed, sometimes quite seriously, to cause haemoperitoneum.

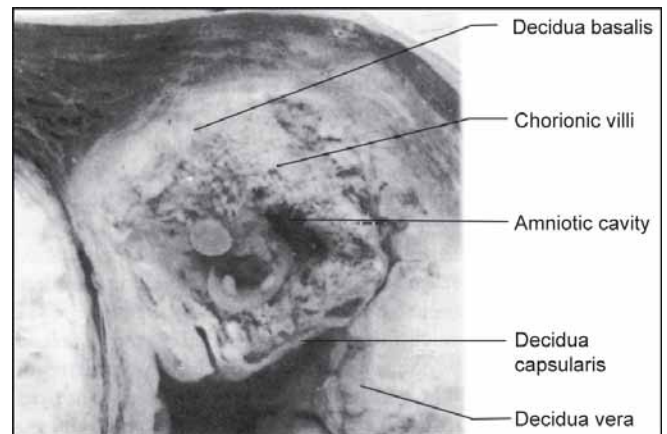
So far as the uterus is concerned, decidual reaction is protective in that it controls the degree of penetration by the chorion and prevents the erosion of large blood vessels. Nevertheless, fine capillaries of the endometrium are opened and the blood leaks out to form pools and lakes around the ovum. The trophoblastic epithelium acts as an intermediary or as a semipermeable membrane.



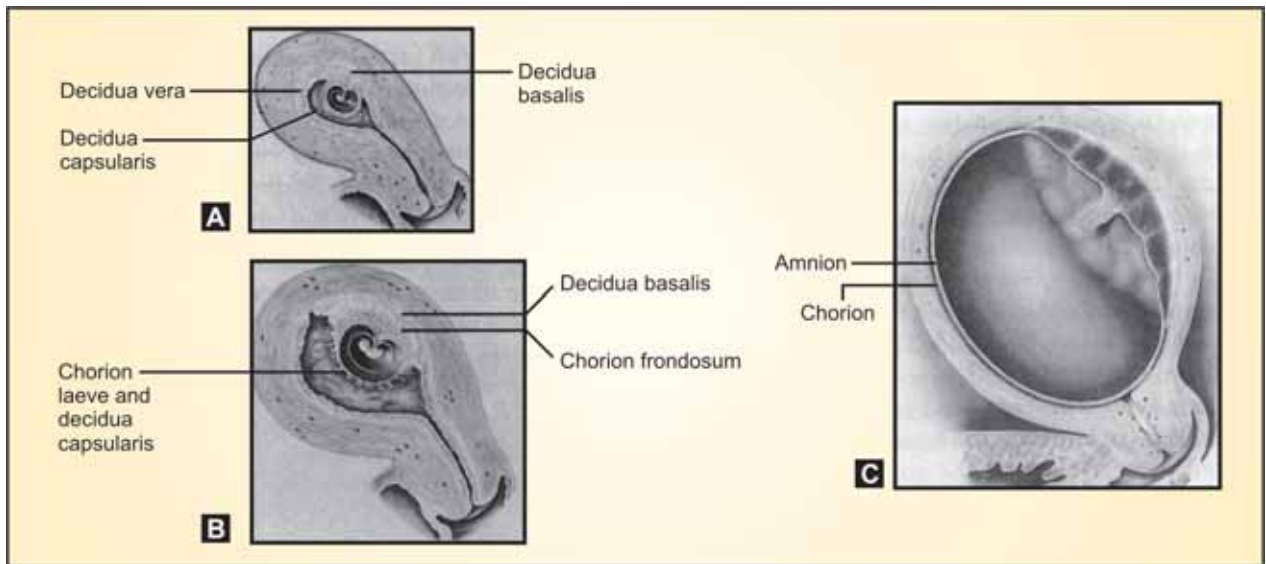
**Fig. 7.6:** A 16-day ovum with differentiation into amniotic sac, yolk sac and embryonic plate. It is surrounded by loose extraembryonic mesoderm and the whole is covered with trophoblast burrowing into the endometrium. This was found as a result of curettage carried out on the twenty-eighth day of a 28-day cycle. (By permission of the Editor of *JAnat* and Professor R.G.Harrison)

To facilitate the interchange of carbon dioxide during the early stages of trophoblastic development, the endometrium is rich in carbonic anhydrase. This forms as a result of a progesterone influence and is probably vital to successful implantation.

The altered endometrium lying deep to the implanted ovum is the *decidua basalis*, and that which shields it from the uterine cavity is the *decidua capsularis*. The lining of the remainder of the uterus is the *decidua vera* (Figs 7.7 and 7.8). The decidua vera and decidua capsularis fuse by 12 weeks of gestation, obliterating the uterine cavity.



**Fig. 7.7:** An early conceptus, with foetal limb buds just showing, embedded in the endometrium. The small cyst near the head of the foetus is probably the yolk sac. The edge of a leiomyoma appears to the left of the pregnancy sac (see Fig. 30.13)

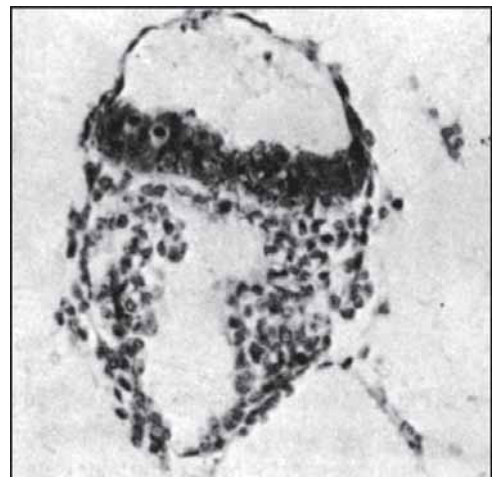


**Figs 7.8A to C:** The formation of the placenta and membranes, (A) At 4 weeks, (B) At 6-8 weeks, (C) At 12 weeks

Thus there is no access to the tubes from the cervix after this time and no possibility of ascending infection.

### FORMATION OF FOETUS AND MEMBRANES

As the cells of the inner cell mass proliferate, a fluid-filled space appears in their midst on the side adjacent to the trophoblast; this is the *amniotic cavity* and its lining cells become the *amnion* (Fig. 7.4). A second cyst lined by a single layer of flattened cells appears on the other aspect of the inner cell mass: this is the *yolk sac*, a primitive structure in the human being (Figs 7.6 and 7.9). These two cavities are separated from each other by a double layer of cells. Between these two layers the mesoderm develops (probably from the amniotic layer), and grows out to form the *body stalk* or *umbilical cord*. The amniotic cavity and yolk sac are present by the seventh day. A reticulum of mesenchyme appears in the blastocyst and condenses to line the trophoblast on its inner aspect. There is now a flat plate between the amnion and the yolk sac comprising three layers - amniotic cells which become *ectoderm*; the intermediate *mesoderm*; and yolk sac cells or *endoderm*. It is from these primary layers that the whole foetus develops. The process of development is one in which the plate folds on itself in two dimensions (Fig. 7.4) so that ultimately a part of the yolk sac is included by the engulfing mesoderm and ectoderm. The



**Fig. 7.9:** A higher-power view of the inner cell mass of the ovum illustrated in Fig. 7.8. This shows the amniotic cavity above and the yolk sac below. Between the two is the embryonic plate consisting of the three primary layers of ectoderm, mesoderm and endoderm from above downwards. (By permission of the Editor of *JAnat* and Professor R.G. Harrison)

resulting tube-like structure stretching from end to end becomes the primitive gut and cloaca. This at first communicates with the remains of the yolk sac (*vitelline duct*) now lying in the body stalk. The *allantois*, also found in the body stalk, is a diverticulum from the primitive gut.

The neural canal forms from an invagination of ectoderm; the mesoderm gives rise to the primitive muscles, blood vessels, bones and all structures intervening between the ectoderm and endoderm.

All the essential structures of the body are present in primitive but recognisable form by the sixth week.

Meanwhile, the trophoblast has developed villous projections on its outer aspect to give it the appearance of a fluffy ball (Fig. 7.10). Mesenchyme invades each villus as a central core. When the trophoblast receives its inner layer of mesoderm it becomes known as *chorion* and its projections become *chorionic villi*. The situation can be summarised thus: Cytotrophoblast + syncytiotrophoblast = trophoblast; trophoblast + mesoderm = chorion.

Chorionic villi are well formed by the fourteenth day. By the twenty-first day, blood vessels have developed from the mesoderm and are found in the foetus itself, in the body stalk and in the core of each villus to form a continuous circulation. The chorionic villi are thus bathed in maternal blood and oxygen. Foodstuffs and foetal waste products are exchanged between this and the foetal blood in the vessels of each villus.

The villi are at first present on all aspects of the blastocyst. As the ovum grows, the decidua capsularis bulges into the uterine cavity and the chorionic villi within it atrophy on the side adjacent to the uterine cavity and persist on the side adjacent to the uterine wall. The part of the chorion still covered with villi is rough and shaggy - the *chorion frondosum*; the part devoid of villi is smooth - the *chorion laeve*. The villi of the chorion frondosum grow and invade the decidua basalis. With further development the chorion frondosum becomes more and more clearly demarcated and restricted to one

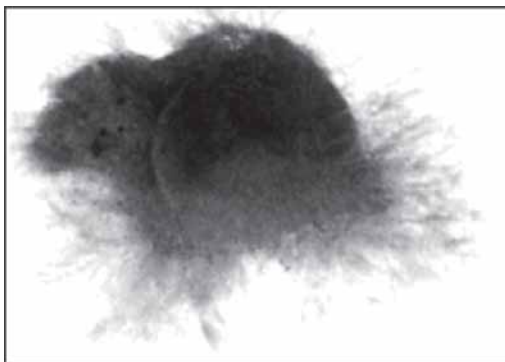


Fig. 7.10: A 3-4-week-old embryo in its amniotic sac, surrounded by chorionic villi

area, giving rise to the *placenta*. This is connected to the foetus by the umbilical cord, the umbilical vessels linking up those of the chorionic villi with those of the foetus.

While the foetus develops and the remains of the yolk sac shrivel, the amniotic cavity grows apace until it completely fills the original blastocyst (Fig. 7.4). It comes into close contact with the chorion and adheres to it lightly; it covers the umbilical cord and is continuous with the skin of the foetus at the umbilicus. The foetus is suspended in amniotic fluid; around this are the *membranes* which consist of an inner glistening thin but tough amnion (Fig. 7.11) and an outer thicker but more friable chorion.

When the ovum fills the uterine cavity the decidua capsularis comes in contact and fuses with the decidua vera lining the opposite pole of the uterus (Fig. 7.8c). The arrangement of the membranes and the placental-foetal relationships then remain essentially unchanged until the end of pregnancy.

As pregnancy progresses, trophoblastic cells continually break away and migrate into the decidua and myometrium; others enter the blood-stream from which they are sieved by the lungs. These are normal and harmless happenings but the decidual reaction to these 'wandering cells', sometimes labelled *syncytial endometritis*, can be mistaken for choriocarcinoma by the histologist. Yet others break away and collect at the

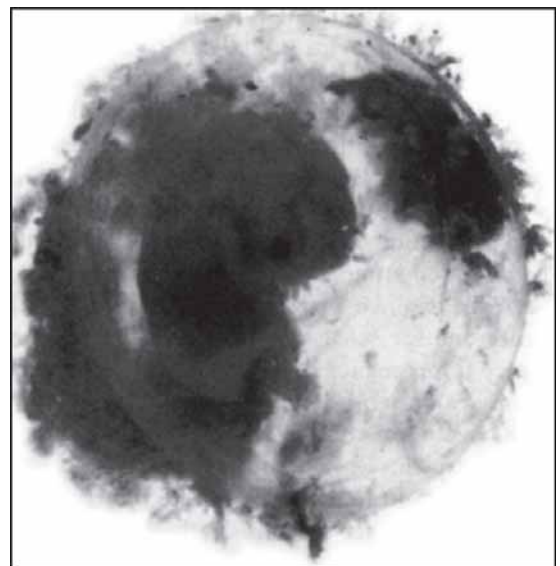


Fig. 7.11: A 5-6-week-old embryo in its amniotic sac. Much of the chorion has been lost. This specimen was found lying free in the peritoneal cavity at operation for tubal pregnancy



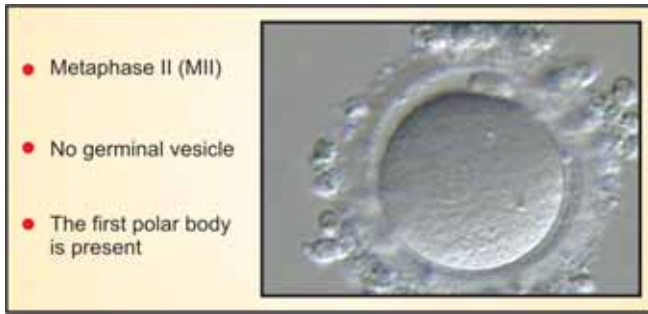


Fig. 7.12: Mature Oocyte

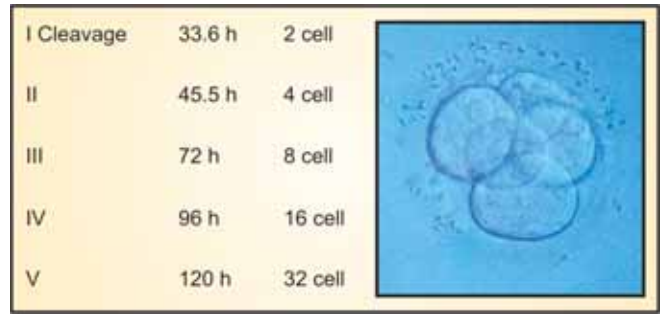


Fig. 7.14: Embryonic development rating (EDR)

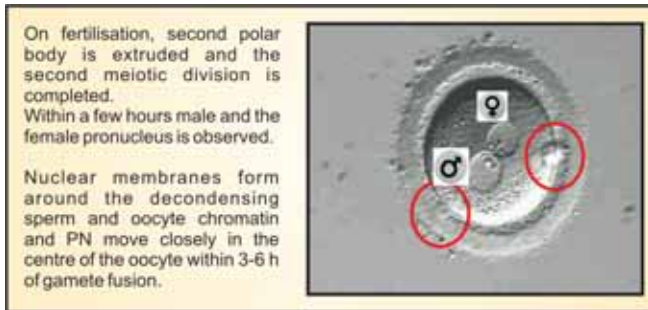


Fig. 7.13: Successful fertilisation

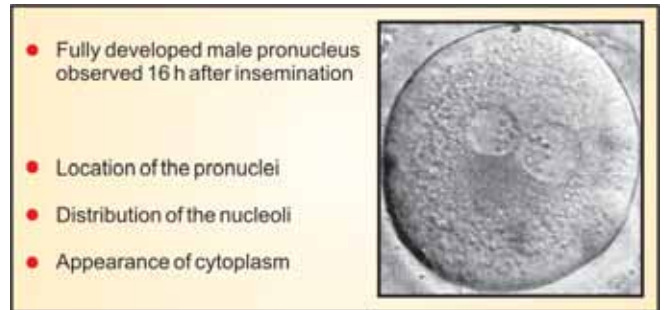


Fig. 7.15: Pronuclear assessment



Fig. 7.16: Different stages of early development from pronuclei to blastocyst stage

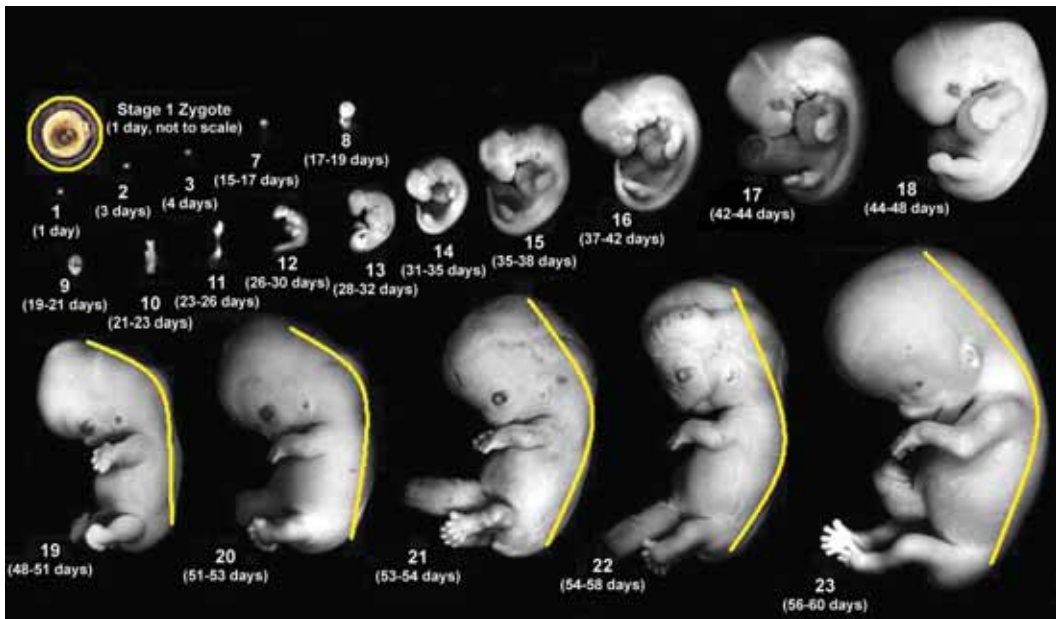


Fig. 7.17: Stages of development

internal os. Transcervical mucus plug aspiration prior to 12 weeks' gestation is a potential technique for first-trimester prenatal diagnosis of aneuploidies, trisomies, etc. which may be less invasive than chorion villus sampling which is done between 9 and 11 weeks for foetal chromosomal disorders but carries the risk of abortion, preterm labour, premature rupture of membranes and foetal limb reduction defects.

### HORMONAL CONTROL OF EARLY PREGNANCY

The fertilised ovum is embedded in the endometrium on about the twenty-first or twenty-second day of the menstrual cycle and by that time is beginning to secrete small amounts of human chorionic gonadotrophin (hCG) which is luteinising and lutetrophic. This prevents the degeneration of the corpus luteum which continues to maintain the progesterational endometrium; amenorrhoea and anovulation result.

### The Corpus Luteum of Pregnancy

The corpus luteum not only persists but continues to enlarge slightly up to the sixtieth day of pregnancy when it may measure 3 cm in diameter. Individual cells are three to four times larger than those of the corpus luteum of menstruation. Soon after the sixtieth day, and presumably because of the dramatic fall in hCG

production at about this time, the corpus luteum temporarily becomes cystic and its activity begins to wane by the tenth week. It shows evidence of colloidal degeneration by the sixteenth week but remains a recognisable structure throughout pregnancy. In the puerperium and after abortion, it occasionally undergoes calcification, but is ultimately absorbed.

### Placental Hormones, Enzymes and Proteins

The placenta produces a wide range of hormones in the syncytiotrophoblast, of which some are clinically different from the comparable maternal hormone. The steroid hormones oestrogen and progesterone cannot be produced by the placenta alone because the necessary enzymes are absent. However, the foetal and maternal adrenals produce the precursors for the placental synthesis of the hormones. As a consequence of the shared biosynthesis of oestrogens by the foetal adrenal and the placenta, the concept of the foetoplacental unit was developed. The placenta transforms foetal adrenal dehydroepiandrosterone sulphate (DHEAS) to oestrogen using a placental sulphatase enzyme. The synthesis of DHEAS is regulated during early pregnancy by hCG and thereafter by foetal ACTH. The placenta synthesises progesterone from maternal and foetal cholesterol throughout pregnancy so that the maternal levels increase steadily during pregnancy.

Only the large protein hormones, hCG and human placental lactogen (hPL) will be discussed in this section, as the roles of the other hormones are largely unknown or speculative. Since the early 1970s, several new proteins of placental origin have been discovered in the maternal circulation and are called placental associated plasma proteins (PAPP). Their concentration increases as pregnancy progresses; rather like hPL. So far no definite physiological functions have been attributed to these proteins.

### Gonadotrophins

Chorionic gonadotrophins, although glycoproteins, differ chemically from pituitary gonadotrophins, but act similarly and have both a follicle stimulating and luteinising action. The latter, however, is dominant.

As soon as the ovum is implanted in the endometrium, the production and excretion of hCG rises rapidly from approximately 100 IU/L in the maternal serum at the time of the expected menses to a maximum of approximately 100,000 IU/L at the sixtieth day of pregnancy; thereafter they fall to a fairly constant low level. The purpose of hCG in circulation in early pregnancy is mainly concerned with maintaining the corpus luteum. Some of the suggested biological functions of hCG include stimulation of placental progesterone production, inhibition of maternal—foetal graft rejection, stimulation of the foetal adrenal and production of DHEAS and stimulation of the foetal gonads, in particular the production of testosterone by the testis.

### Human Placental Lactogen (HPL)

This hormone, also known as chorionic somatomammotrophin (hCS), is also secreted by the syncytiotrophoblast. It is demonstrable in the plasma by the sixth week of pregnancy and rises to a maximum in the third trimester of pregnancy to disappear quickly after delivery. It is a protein hormone with immunological and certain biological similarities to growth hormone (GH). As its alternative name implies, it is growth-promoting, but is less than one-twentieth as effective as GH, and is lactogenic, although this has only been proved in other animal species. Its action is weak compared with pituitary prolactin.

The hormone participates, directly or indirectly, in a number of metabolic processes. It has been suggested that it may function as a metabolic regulatory, albeit a

fine one, in the mother to ensure that the nutritional requirements of the foetus are met. In the mother, hPL induces insulin resistance and carbohydrate intolerance. It mobilises lipids as free fatty acids. Thus it ensures an adequate supply of fuels to the foetus between maternal meals. Alterations in the levels of hPL have been used in early pregnancy to assess viability in cases of threatened abortion, and in late pregnancy as an indication of placental function. However, biophysical techniques are more reliably predictive and sensitive for assessing foetal well-being.

### Progesterone

The activity of the corpus luteum of pregnancy explains the slight rise in the level of progesterone in the blood during the first few days or weeks following conception. The placenta, however, soon takes over responsibility for producing progesterone in ever-increasing amounts until term or near term. The daily production of progesterone in late pregnancy is about 250 mg with blood levels of 100-200 ng/ml. Progesterone helps prepare and maintain the endometrium to permit implantation. It may have a role in suppressing maternal immunological response to foetal antigens, thus preventing maternal rejection. It reduces myometrial contractility. It also serves as the substrate for some of the foetal adrenal gland production of gluco- and mineralocorticoids. The increased progesterone levels have an effect on the kidneys since progesterone competes with aldosterone for renal receptor sites. The sodium balance in pregnancy reflects, to some extent, the increased aldosterone and progesterone levels.

The secretion of progesterone by the human placenta explains why, in women, the corpus luteum is not important to the maintenance of pregnancy in contrast to other animals. In the human being both ovaries, including the corpus luteum, can be removed in the first trimester without abortion taking place in 50 per cent of cases. There are reports of the human corpus luteum having been removed as early as the twenty-third day of the menstrual cycle (presumed ninth day of pregnancy) without untoward effect.

Nevertheless, if it is removed within the first 4 weeks (6 weeks' amenorrhoea), abortion usually occurs within 80 hours.

This is the basis for the use of the antiprogestogen RU 486 (mifepristone) for medical induction of abortion in the early first trimester.

## Oestrogens

These hormones are produced in ever-increasing quantities from the beginning to the end of pregnancy. The corpus luteum makes a contribution in the first few weeks but the main source, as described above, is the placenta. This secretes oestradiol, oestrone and oestriol. Oestrone and oestradiol levels increase to about 100 times the non-pregnant levels, but oestriol excretion is increased about 1000 times. Although oestriol is a weak oestrogen, its high concentrations compensate and the biological effect is equivalent to oestradiol. If the foetus is removed and the placenta remains *in situ*, as in some cases of abdominal pregnancy, the level of oestriol falls considerably. This level is also low if foetal adrenal function is defective as it is with anencephaly. The level

of unconjugated oestriol along with levels of maternal serum alpha-fetoprotein and maternal serum hCG form the *triple test* which is used antenatally to screen for foetal aneuploidy. Here, unconjugated oestriol and AFP levels are low whereas the hCG level is raised. Most of the oestrogens found in the blood and urine are in a biologically inactive form, being conjugated with glucuronic acid. Only about 8-10 per cent of maternal serum oestradiol is unconjugated.

The role of oestrogens in pregnancy is not clearly defined, although there is hardly an organ or tissue which is not, directly or indirectly, affected to some extent during pregnancy. The hypertrophy and hyperplasia of the uterine muscle and development of the breast tissue are obvious target-organ effects but much still remains unknown.

# CHAPTER 8

## Spontaneous Abortions (Including Recurrent Loss)

Spontaneous Abortion	131
Pathology	131
Clinical Varieties	135
Recurrent Early Pregnancy Loss	138

The definition of abortion is the termination of pregnancy by any means before the foetus is sufficiently developed to survive. In the United States this definition is confined to the termination of pregnancy before 20 weeks based upon the date of the first day of the last normal menses. Another commonly used definition is the delivery of a foetus-neonate that weighs less than 500 g.

### SPONTANEOUS ABORTION

When abortion occurs without medical or mechanical means to empty the uterus, it is referred to as spontaneous. Another widely used term is miscarriage.

### PATHOLOGY

Haemorrhage into the decidua basalis and necrotic changes in the tissues adjacent to the bleeding usually accompany abortion. The ovum becomes detached, and this stimulates uterine contractions that result in expulsion. When the sac is opened, fluid is commonly found surrounding a small macerated foetus, or alternatively there may be no visible foetus in the sac, the so-called blighted ovum.

Blood or carneous mole is an ovum that is surrounded by a capsule of clotted blood. The capsule is of varying thickness, with degenerated chorionic villi scattered through it. The small, fluid-containing cavity within appears compressed and distorted by thick walls of old blood clot. The incidence of spontaneous abortion is about 15 per cent of all pregnancies.

More than 80 per cent of abortions occur in the first 12 weeks, and the rate decreases rapidly thereafter. Chromosomal anomalies cause at least half of these early abortions, and their incidence likewise decreases thereafter.

1. *Chromosomal abnormalities*: Cause at least 50 per cent of early abortions e.g. trisomy, monosomy X (XO) and triploidy (Fig. 8.1).
2. *Blighted ovum (anembryonic gestational sac)*: Where there is no visible foetal tissues in the sac.
3. *Maternal infections*: e.g. listeria monocytogenes, mycoplasma hominis, ureaplasma urealyticum, cytomegalovirus and toxoplasma gondii which causes



Fig. 8.1: USG picture of YS and embryo

abortion if there is acute infection early in pregnancy. Acute fever for whatever the cause can induce abortion.

4. **Trauma:** External to the abdomen or during abdominal or pelvic operations.
5. **Endocrine causes:**
  - a. Progesterone deficiency (causes abortion between 8-12 weeks).
  - b. Diabetes mellitus.
  - c. Hyperthyroidism.
6. **Drugs and environmental causes:** e.g. quinine, ergots, severe purgatives, tobacco, alcohol, arsenic, lead, formaldehyde, benzene and radiation.
7. Maternal anoxia and malnutrition.
8. Overdistension of the uterus: e.g. acute hydramnios.
9. **Immunological causes:**
  - a. Systemic lupus erythematosus.
  - b. Antiphospholipid antibodies that are directed against platelets and vascular endothelium leading to thrombosis, placental destruction and abortion.
  - c. Histocompatibility between the mother and father and in turn the foetus. It is assumed that histoincompatibility particularly in human leucocyte antigen (HLA- DR locus) is essential for stimulation of the immune system to produce blocking factors which prevent rejection of the foetus.
10. Ageing sperm or ovum.
11. **Uterine defects:** e.g. Septum, Asherman's syndrome (intrauterine adhesions) and submucous myomas.

12. Nervous, psychological conditions and over fatigue.
13. Idiopathic.

Autosomal trisomy is the most frequently identified chromosomal anomaly associated with first-trimester abortions. Trisomies can be the result of an isolated nondisjunction, maternal or paternal balanced translocation, or balanced chromosomal inversion. Balanced structural chromosomal rearrangements are present in 2 to 3 per cent of couples with a history of recurrent abortions. Translocations may be identified in either parent. Balanced chromosomal inversions may also be identified in couples with recurrent abortions. Trisomies for all autosomes except chromosome number 1 have been identified in abortuses, but autosomes 13, 16, 18, 21, and 22 are most common.

Monosomy X (45, X) is the next most common chromosomal abnormality and is compatible with live-born females (Turner syndrome). Triploidy is often associated with hydropic placental degeneration. Incomplete hydatidiform moles may have foetal development that is triploid or trisomic for chromosome number 16. Foetuses associated with these frequently abort early, and the few carried longer are all grossly malformed. Advanced maternal and paternal age are not associated with this abnormality. Tetraploid abortuses are rarely live born and are most often aborted very early in gestation.

Chromosomal structural abnormalities are unusual causes of abortion and have been identified only since the development of banding techniques. Some of these infants are live born with balanced translocations and can be normal. Autosomal monosomy is extremely rare and is incompatible with life. Sex chromosomal polysomy (47,XXX or 47,XXY) is unusual in abortus material but is commonly seen in live births. In women with genetic problem can be offered chorion villi sampling (Fig. 8.2).

**Euploid Abortion:** Three fourths of aneuploid abortions are before 8 weeks, while euploid abortions peaked at about 13 weeks.

The following causes are possibilities:

1. A genetic abnormality such as an isolated mutation or polygenic factors. Approximately 0.5 per cent of live births have chromosomal abnormalities, while at least 2 per cent of live births have diseases associated with a single-gene mutation or a polygenic mechanism of inheritance.

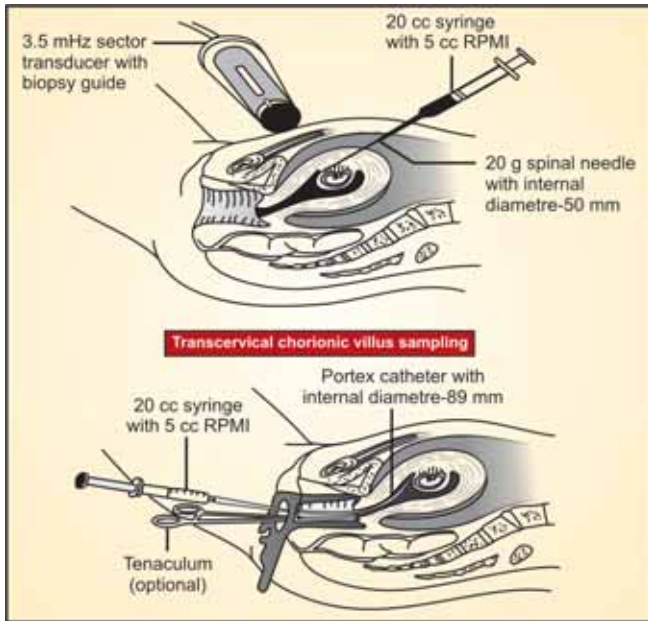


Fig. 8.2: Chorionic villi in spontaneous abortion

2. Various maternal factors.

- a. **Infections:** Some chronic infections have been implicated in causing abortion. There is no evidence in humans that either *Listeria monocytogenes*, *Brucella* or *Chlamydia trachomatis* produce abortions. Herpes simplex, however, has been associated with an increased incidence of abortion following genital infection in early pregnancy. The association of *Mycoplasma hominis* and *Ureaplasma urealyticum* in abortion was suggested by few. However, there was no evidence of spontaneous abortion with genital mycoplasma.
- b. **Endocrine abnormalities:** There does not appear to be an increased incidence of abortion associated with clinical hypothyroidism. Diabetes Mellitus who are insulin dependent have a higher incidence of spontaneous abortion and major congenital malformations.
- c. **Progesterone deficiency:** Insufficient progesterone secretion by the corpus luteum or placenta has been associated with an increased incidence of abortion. It has been suggested that abnormal levels of one or more hormones might help to forecast abortion. Unfortunately, reduced levels of these hormones are usually the consequence

rather than the cause. Luteal phase deficiency is uncommon.

- d. There is no conclusive evidence that dietary deficiency of any one nutrient or moderate deficiency of all nutrients is an important cause of abortion. The nausea and vomiting that develop rather commonly during early pregnancy, and any inanition so induced, are rarely followed by spontaneous abortion.
- e. **Drug use and environmental factors:** Different agents has been reported, but not confirmed, to be associated with an increased incidence of abortion. However this is not proved.
- f. **Smoking:** This has been associated with an increased risk for euploidic abortion.
- g. **Alcohol:** Both spontaneous abortion and foetal anomalies may result from frequent alcohol use during the first 8 weeks of pregnancy.
- h. **Caffeine:** Coffee consumption at greater than four cups per day appears to slightly increase the risk of abortion. This may be due to paraxanthine (a caffeine metabolite) levels of which are associated with a significant two-fold risk of spontaneous abortion. However moderate consumption of caffeine is unlikely to be associated with spontaneous abortion.
- i. **Radiation:** In sufficient doses, radiation is a recognised abortifacient.
- j. **Environmental toxins:** In most instances, there is little information to indicate any specific environmental agent; however, there is evidence that arsenic, lead, formaldehyde, benzene, and ethylene oxide may cause abortion.
- k. **Immunological factors:** Much attention has been focused on the immune system as important in recurrent pregnancy loss. Two primary pathophysiological models that have evolved are the autoimmune theory (immunity against self) and the alloimmune theory (immunity against another person).
- l. **Autoimmune factors:** It has been determined from compiled studies that approximately 15 per cent of over 1000 recurrent pregnancy loss patients have recognised autoimmune factors. The most significant antibodies have specificity against negatively charged phospholipids and are most commonly detected by testing for lupus anti-coagulant (LAC) and anticardiolipin antibody (ACA).

The lupus anticoagulant is an immunoglobulin (IgG, IgM, or both) that interferes with one or more of the phospholipid-dependent tests of *in vitro* coagulation. The term is a misnomer because it is associated with clinically important increases in thromboembolic events. Importantly, the lupus anticoagulant is most often diagnosed in patients who do not meet the diagnostic criteria for lupus.

- m. Antiphospholipid antibodies are acquired antibodies targeted against a phospholipid. They can be of the IgG, IgA, or IgM isotope. The mechanism of pregnancy loss in these women is thought to involve placental thrombosis and infarction.

Investigators have proposed various treatments for the antiphospholipid antibody syndrome, including low-dose aspirin, prednisone, heparin, and intravenous immunoglobulin. These treatments are thought to counteract the adverse action of antibodies by affecting both the immune and coagulation systems.

- n. *Alloimmune factors*: A number of women with recurrent pregnancy loss have been diagnosed as having an alloimmune cause. They have received a variety of therapies targeted at stimulating maternal immune tolerance of foetal material. Diagnosis of an alloimmune factor has centered on several tests:

- Maternal and paternal HLA comparison.
- Assessment of maternal serum for the presence of cytotoxic antibodies to paternal leukocytes.
- Maternal serum testing for blocking factors for maternal-paternal mixed lymphocyte reactions. In essence, those couples determined to have significant HLA-type homology, or in which the women were found to have minimal antipaternal antibodies, were judged to represent an alloimmune disorder. This view is doubtful.

- o. *Inherited thrombophilia*: There have been numerous reports of an association of spontaneous abortions and inherited thrombophilias. It has been found to have increased incidence of activated protein C resistance and factor V Leiden mutation. Some reported that elevated serum homocysteine levels were also a risk factor.

The optimal treatment for the various thrombophilias during pregnancy is unclear, but heparin

(including low molecular weight heparin) appears to be efficacious for the treatment of antithrombin III deficiency as well as protein C and S deficiency. Aspirin plus heparin seems to be efficacious for treatment of factor V Leiden mutation and antiphospholipid syndrome.

- p. *Aging gametes*: Some researchers found an increased incidence of abortion relative to successful pregnancies when insemination occurred 4 days before or 3 days after the time of shift in basal body temperature. They concluded, therefore, that aging of the gametes within the female genital tract before fertilisation increased the chance of abortion.
- q. *Uterine defects and acquired uterine defects*: Large and multiple uterine leiomyomas usually do not cause abortion. Uterine synechiae (Asherman syndrome) are caused by destruction of large areas of endometrium by curettage. This in turn results in amenorrhoea and recurrent abortions believed to be due to insufficient endometrium to support implantation.
- r. *Defects*: These defects are the consequence of abnormal müllerian duct formation or fusion; Some types, such as uterine septa, may be associated with abortions.
- s. *Incompetent cervix*: The term incompetent cervix is applied to a discrete obstetrical entity. It is characterised by painless cervical dilatation in the second trimester or perhaps early in the third trimester, with prolapse and ballooning of membranes into the vagina, followed by rupture of membranes and expulsion of an immature foetus. Unless effectively treated, this sequence tends to repeat in each pregnancy.

Numerous methods have been described in nonpregnant women to make the diagnosis, usually by documenting a more widely dilated internal cervical os than is normal. Methods have included hystero-graphy, pull-through techniques of inflated catheter balloons, and acceptance without resistance at the internal os of specifically sized cervical dilators. It is not recommended to do the tests inbetween pregnancies. During pregnancy, attempts have been made with moderate success to predict premature cervical dilation using ultrasonic techniques. Ultrasound is useful in identifying women with subtle changes in the cervix who would benefit from urgent cerclage.



There is little doubt that ultrasound, especially transvaginal sonography (TVS), is a useful adjunct for the diagnosis of cervical shortening or funneling of the internal os and in the early detection of cervical incompetence. Endovaginal sonography has been shown to be a reproducible and safe method to assess cervical length objectively when compared to digital examination or abdominal or perineal ultrasound. Earlier studies used transabdominal ultrasound. This technique required a full bladder to visualise the cervix, which often falsely elongated the apparent cervical length introducing an unpredictable effect on measurement. The Transvaginal sonography (TVS) has become the gold standard. Ultrasound images of the cervix in pregnancy have demonstrated that cervical effacement begins at the internal cervical os and proceeds distally through a process called funneling. This process is usually established prior to dilatation of the external cervical os and can begin as early as 16-24 weeks in patients who eventually deliver preterm. Zilanti et al described the appearance of cervical effacement as seen by TVS as progression of the letters T, Y, V and U to denote the relationship of the lower uterine segment to the axis of the cervical canal.

The mean cervical length is 35-40 mm from the 14-22 weeks and falls to approximately 35 mm between 24-28 weeks and 30 mm after 32 weeks. The cervical length from 22-32 weeks gestation displays a normal bell-shaped distribution, with the 50th percentile approaching approximately 35 mm and the 10th and 90th percentile at 25 mm and 45 mm respectively. Hence a cervix below 25 mm at mid pregnancy is suggestive of short cervix.

A good evidence in the literature shows that inflammation contributes to preterm labour and it is shown that a short cervix predisposes to inflammation. A cervix less than 15 mm has very high incidence of preterm labour. Insertion of cervical suture may not substantially reduce the risk of prematurity. However, when diagnosed along with aggressive preterm tocolysis, antibiotics etc will help in a good number of those women otherwise would have delivered preterm. Hence TVS has a good positive predictive and negative predictive value for preterm labour and therefore could be used as a screening method in pregnancy.

3. **Paternal factors:** Little is known about paternal factors in the genesis of spontaneous abortion. Certainly, chromosomal translocations in sperm can lead to

abortion. DNA abnormalities may be contributory in these cases and it may be worth assessing this.

### Mechanism of Abortion

- Up to 8 weeks:* The gestational sac tends to be expelled complete and the decidua is shed thereafter.
- From 8-12 weeks:* The decidua capsularis ruptures and the embryo is expelled either entire or after rupture of the amnion.
- After 12 weeks:* The placenta is completely formed and the process of abortion is like a miniature labour. It is more common for the foetus to be expelled but for the placenta to be retained due to firmer attachment to the uterine wall (Figs 8.3 and 8.4).

### CLINICAL VARIETIES

#### *Threatened Abortion*

*Clinical picture:* Symptoms and signs of pregnancy coincide with its duration.

Vaginal bleeding slight or mild, bright red in colour originating from the choriodecidual interface. Pain is absent or slight. Cervix is closed. Pregnancy test is positive. Ultrasonography shows a living foetus.

*Prognosis:* With or without treatment if the foetus is normal in chromosomes the chances of pregnancy continuation is 85 per cent.

*Treatment:* Rest in bed until one week after stoppage of bleeding. No intercourse as it may disturb pregnancy by the mechanical effect and the effect of semen prostaglandins on the uterus. Sedatives can be used if the patient is anxious. Progestogens and its role is controversial. However, low plasma progesterone level is an indication of pregnancy failure. Progestogens may cause retention of the dead ovum leads to missed abortion. Gonadotrophins (hCG) may be of benefit in cases of luteal phase deficiency which is once again not proved.

#### *Inevitable Abortion*

*Clinical picture:* Symptoms and signs of pregnancy coincide with its duration. Vaginal bleeding is excessive and may be accompanied with clots.

Pain is colicky felt in the suprapubic region radiating to the back. The internal os of the cervix is dilated and products of conception may be felt through it.

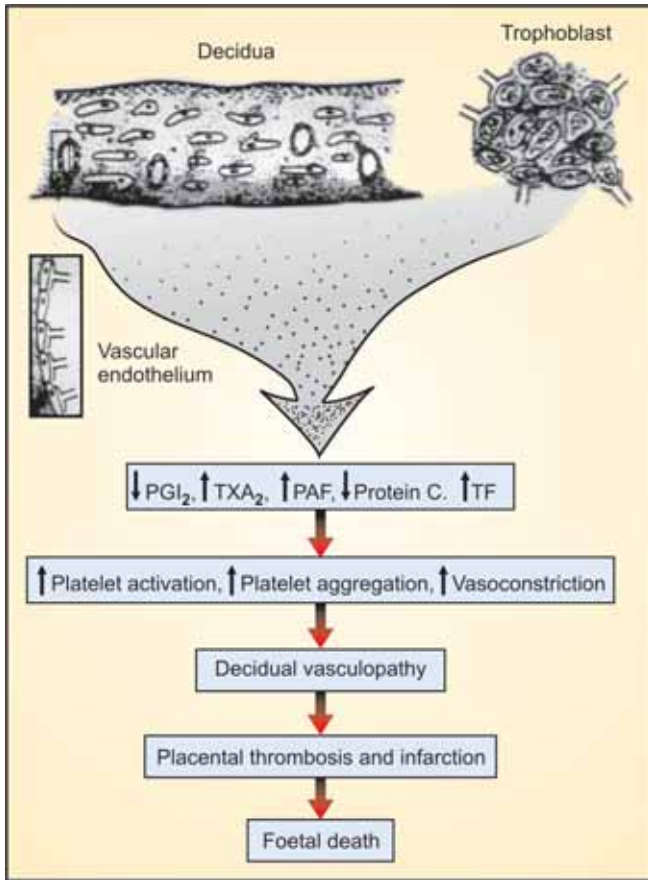


Fig. 8.3: Proposed mechanisms of foetal loss

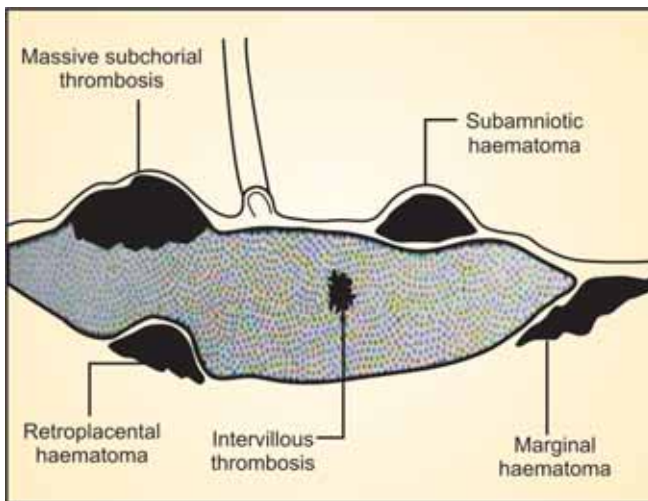


Fig. 8.4: Threatened abortions

Rupture of membranes between 12-28 weeks is a sign of the inevitability of abortion.

*Treatment:* Any attempt to maintain pregnancy is useless.

Resuscitation and ergometrine 0.5 mg is given by IM or IV route to induce tetanic uterine contraction and stop bleeding.

- I. If pregnancy is less than 12 weeks: Termination is done by vaginal evacuation and curettage or suction evacuation under general anaesthesia.
- II. If pregnancy is more than 12 weeks:
  - Oxytocin is given by intravenous drip to expel the uterine contents.
  - If the placenta is retained it is removed under general anaesthesia.

*Cervical abortion:* is a variety of inevitable abortion in which the products of conception has been separated from the uterine cavity but retained in the cervical canal causing its distension.

#### **Clinical Picture**

- The patient complains of considerable bleeding and severe lower abdominal pain referred to the back.
- On examination, the products of conception is felt through the dilated cervix.

*Treatment:* Under anaesthesia, the cervix is dilated, contents is removed and cavity is curetted to remove the decidua.

#### **Incomplete Abortion**

Retention of a part of the products of conception inside the uterus. It may be the whole or part of the placenta which is retained.

*Clinical picture:* The patient usually noticed the passage of a part of the conception products. Bleeding is continuous. On examination, the uterus is less than the period of amenorrhoea but still large in size. The cervix is opened and retained contents may be felt through it.

*Ultrasonography:* shows the retained contents.

*Treatment:* Complete the process by evacuation.

#### **Complete Abortion**

- All products of conception have been expelled from the uterus.
- *Clinical picture:* The bleeding is slight and gradually diminishes. The pain ceases.

- The cervix is closed. The uterus is slightly larger than normal.
- *Ultrasound*: shows empty cavity.

### Missed Abortion

Retention of dead products of conception for 4 weeks or more.

Carneous mole is a special variety of missed abortion in which the dead ovum in early pregnancy is surrounded by clotted blood.

### Clinical picture

*Symptoms*: Symptoms of threatened abortion may or may not be developed.

Regression of pregnancy symptoms as nausea, vomiting and breast symptoms.

The abdomen does not increase and may even decrease in size. The foetal movements are not felt or ceases if previously present. Milk secretion may start particularly in second trimester abortion because of the decline in oestrogens secretion that were normally blocking the action of prolactin on the breasts. A dark brown vaginal discharge may occur (prune juice discharge).

*Signs*: The uterus fails to grow or even decreases in size and becomes firmer. The cervix is closed.

*Investigations*: Pregnancy test becomes negative within two weeks from the ovum death, but it may remain positive for a longer period due to persistent living chorionic villi. Ultrasound shows either a collapsed gestational sac, absent foetal heart movement or foetal movement (Fig. 8.5).

*Complications*: Disseminated intravascular coagulation (DIC) may occur if the dead conceptus is retained for more than 4 weeks and superadded infection.

*Treatment*: The dead conceptus is expelled spontaneously in the majority of cases. Evacuation of the uterus is indicated in the following conditions: spontaneous expulsion does not occur within four weeks. However, in clinical practice one does not wait for too long as there is an increased psychological feelings in the woman and her relatives. Hence the same may be evacuated either medically or surgically depending on the size of the uterus. The other indications to interfere is that when there is bleeding or infection or DIC.

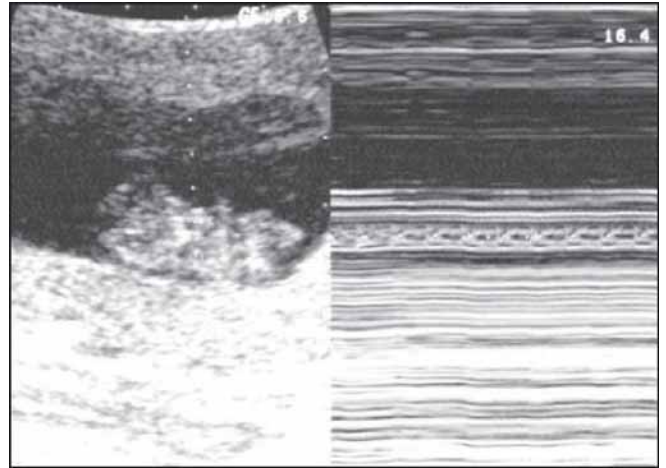


Fig. 8.5: Foetal cardiac activity

### Evacuation is carried out as following:

If the uterine size is less than 12 weeks' gestation: vaginal or suction evacuation is done. If the uterine size is more than 12 weeks' gestation : evacuation can be done by :

- a. *Prostaglandins*: given intravaginally (PGE<sub>2</sub>), intravenously, intra-or extra- amniotic (PGF<sub>2α</sub>).
- b. Oxytocin infusion.
- c. *Combination*: starting with prostaglandin and completed with oxytocin.
- d. *Hysterotomy*: is not done in modern methods of evacuation.

### Septic Abortion

It is any type of abortion, usually criminal abortion, complicated by infection.

*Microbiology*: E. Coli, bacteroids, anaerobic streptococci, clostridia, streptococci and staphylococci are among the most causative organisms.

### Clinical picture

#### General examination:

- Pyrexia and tachycardia.
- Rigors suggest bacteraemia.
- A subnormal temperature with tachycardia is ominous and mostly seen with gas forming organisms.
- Malaise, sweating, headache, and joint pain.
- Jaundice and/or haematuria is an ominous sign, indicating haemolysis due to chemicals used in

criminal abortion or haemolytic infection as *clostridium welchii*.

**Abdominal examination**

- Suprapubic pain and tenderness.
- Abdominal rigidity and distension indicates peritonitis.

**Local examination**

- Offensive vaginal discharge. Minimal inoffensive vaginal discharge is often associated with severe cases. Uterus is tender, products of conception may be felt, local trauma may be detected. Fullness and tenderness of Douglas pouch indicates pelvic abscess which will be associated with diarrhoea.

**Complications**

Endotoxic (septic) shock may develop with its serious sequels as acute renal failure and DIC.

**Treatment**

- Isolate the patient. Bed rest.
- An intravenous line is established for therapy. In case of shock a central venous pressure (CVP) line when needed to aid in the control of fluid and blood transfusion is added.
- Observation for vital signs: pulse, temperature and blood pressure as well as fluid intake and urinary output. A cervico-vaginal swab is taken for culture (aerobic and anaerobic) and sensitivity,
- **Antibiotic therapy:** Ampicillin or cephalosporin (as a broad spectrum) + gentamycin (for gram -ve organisms) + metronidazole (for anaerobic infection) are given by intravenous route while awaiting the results of the bacteriological culture. Another regimen to cover the different causative organism is clindamycin + gentamycin.
- **Fluid therapy:** e.g. glucose 5 per cent normal saline and/or lactated ringer solutions can be given as long as there is no manifestations of acute renal failure particularly the urinary output is more than 30 ml/hour.
- **Blood transfusion:** is given if CVP is low (normal: 8-12 cm water). It is of importance also to correct anaemia coagulation defects and infection.
- Anti-gas gangrene (in *Cl.welchii*) and antitetanic serum (in *Cl. tetani*).
- **Oxytocin infusion:** To control bleeding and enhances expulsion of the retained products.

- Surgical evacuation of the uterus can be done after 6 hours of commencing IV therapy but may be earlier in case of severe bleeding or deteriorating condition in spite of the previous therapy.
- Hysterectomy may be needed in endotoxic shock not responding to treatment particularly due to gas gangrene (*Cl. welchii*).

**RECURRENT EARLY PREGNANCY LOSS**

Recurrent miscarriage (RM) is traditionally defined as three or more consecutive miscarriages occurring before 20 weeks of pregnancy. Majority of RM cases following investigations are classified as idiopathic, that is, no identifiable cause in either partner, it is generally accepted that within the idiopathic group there is considerable heterogeneity and it is unlikely that one single pathological mechanism can be attributed to their RM history.

**Aetiology (Fig. 8.6)**

*Coagulation Investigations*

Acquired maternal thrombophilia is a well-recognized cause of RM. All women with a history of three or more early pregnancy losses, that is, before 10 weeks, or 1 or more unexplained deaths at 10 weeks of a morphologically normal foetus, or 1 or more premature births at 34 weeks with severe pre-eclampsia or placental insufficiency, should be offered a testing for lupus anticoagulant (LAC) and anticardiolipin antibodies

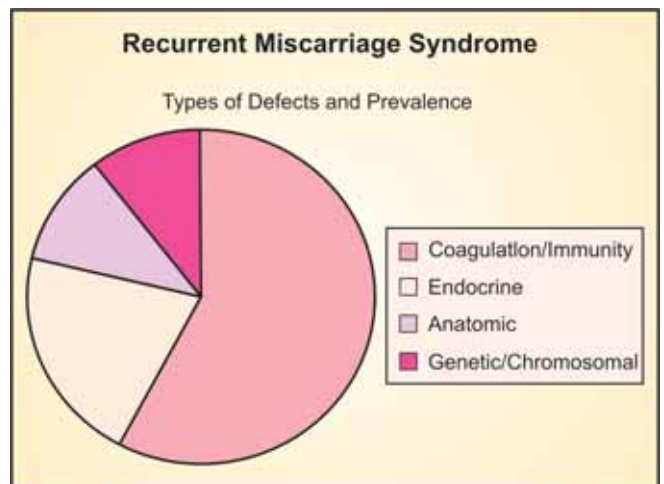
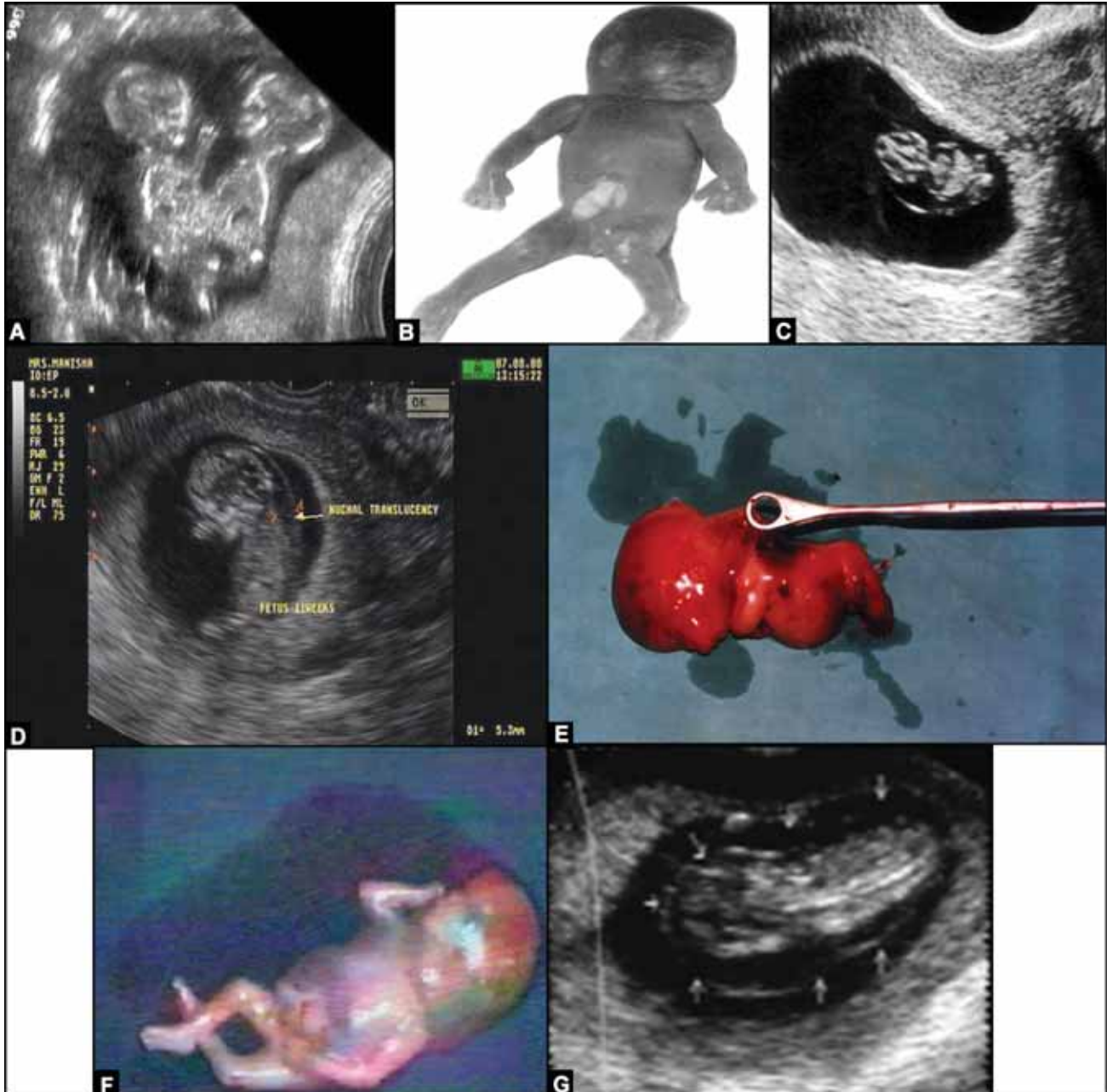


Fig. 8.6: Aetiology

(ACA), known collectively as antiphospholipid antibodies (APA), to exclude an antiphospholipid syndrome (APS). More recently, an increased incidence of early and recurrent foetal loss has also been suggested in women with inherited thrombophilia, including Factor V Leiden deficiency, activated protein C

resistance, prothrombin G20210A and protein S deficiency. Other coagulation abnormalities, including impaired fibrinolytic activity, factor XII deficiency and reduced activated partial thromboplastin time have also been reported to be associated with RM, but the corresponding epidemiological data are limited.



Figs 8.7A to G: Genetic anomalies in embryo

### Endocrinologic Investigations

Early epidemiological data have shown an association between RM and hypothyroidism or diabetes mellitus. Although current evidence indicates that treated hypothyroidism and well controlled diabetes are not associated with RM, it is better to rule out the same with a TSH levels and blood sugars for diabetes mellitus. Obesity certainly has a wider impact on women's health, and several studies have shown that the association between polycystic ovary syndrome (PCOS) and RM could be secondary to the association between obesity and miscarriage.

### Immunologic Investigations

An excessive maternal immune response against paternal antigens resulting in abnormal immune cells and cytokine production has and is thought to be one of the causes of RM but no definitive data has been found.

### Parental Cytogenetic Investigation

The incidence of structural chromosome abnormalities, usually a balanced translocation is increased in couples with RM. A high resolution 11-14 weeks scan can pick up many markers of genetic anomalies (Figs 8.7A to G).

*Cytogenetic studies in the abortus:* The risk of live born trisomy following an aneuploidy in a sporadic early pregnancy failure is around 2 per cent. By contrast, chromosomal analyses of the products of conception in couples with RM indicate that a normal conceptus karyotype in a previous pregnancy is a predictor of subsequent miscarriage since chromosomal abnormalities in recurrent early pregnancy loss is not seen.

*Uterine anomalies:* Using 3D ultrasound, it has been reported that women with a subseptate uterus have a higher incidence of first trimester loss, whereas women with an arcuate uterus have a greater proportion of second trimester loss and preterm delivery. However uterine anomalies per say does not contribute to increased incidence of RM (Figs 8.8A and B).

*Other investigations:* High level of homocysteine (hyperhomocysteinaemia) can be associated with RM. Among the genetic causes of this condition, a common one is polymorphism at position 677 in the *methyl tetrahydrofolate reductase (MTHFR)* gene, which in the homozygous form leads to a thermolabile enzyme variant. Within this context, low plasma folate levels have been associated with an increased risk of first trimester miscarriage.

*Infections:* Toxoplasmosis, Rubella, cytomegalovirus, herpes (TORCH) screen is of limited value in the investigation of RM.



Fig. 8.8A: 3D ultrasound septate



Fig. 8.8B: Hysteroscopy showing septum

*Management:* Aspirin and/or heparins have become routine treatment for women with APS and inherited thrombophilias and a history of RM, on the basis of limited evidence. There seems to be a considerable medical use of progestogens and there is currently insufficient information to allow recommendations regarding optimal dose, route and timing of progesterone supplementation. A recent systematic review found no

evidence to support the routine use of progesterone in the first trimester to prevent miscarriage.

The use of intravenous immunoglobulin (IVIG), anti-TNF, glucocorticoids or cellular therapies in order to prevent or reduce an 'excessive immune response remains controversial. A small number of non-randomised studies have reported that psychological support, that is, tender loving care (TLC) in early pregnancy, decreases miscarriage rates in women with unexplained RM.

# CHAPTER 9

## Ectopic Pregnancy

Tubal Pregnancy	144
Ovarian Pregnancy	155
Cornual Pregnancy	156
Cervical Pregnancy	157
Abdominal Pregnancy	157
Intraligamentary Pregnancy	159

### Definition

An ectopic pregnancy is one in which the fertilised ovum becomes implanted in a site other than the normal uterine cavity. Although *extrauterine pregnancy* is often used as a synonymous term, it is different in that it does not include certain rare types such as pregnancy in the rudimentary horn of a bicornuate uterus. Ectopic pregnancy is the consequence of an abnormal implantation of the blastocyst.

### Frequency

Ectopic pregnancy is seen in about 2 per cent of all pregnancies in USA, 3-4 per cent worldwide incidence. In some studies the incidence reported is as high as 16 ectopic pregnancy for 1000. The incidence of ectopic pregnancy has risen in the past 20 years due to various reasons like predisposing factors and also better diagnostic techniques.

Ectopic pregnancy is the leading cause of maternal mortality in USA (10-15%).

### Sites of Ectopic Pregnancy

Any pregnancy occurring outside the uterine cavity is labelled as ectopic pregnancy. The possible sites can be classified according to above downwards and according to frequency.

#### *Above downwards*

1. Abdominal cavity
2. Ovary
3. Fallopian tubes
4. Broad ligament
5. Rudimentary horn of uterus
6. Cervix



### Frequency

- |                                       |                |
|---------------------------------------|----------------|
| 1. Fallopian tubes                    | 95-98 per cent |
| 2. Uterine cornu                      | 2-2.5 per cent |
| 3. Ovary, cervix and abdominal cavity | <1 per cent    |
- Ectopic pregnancy is commoner on the right side.

### Risk Factors

1. Pelvic inflammatory diseases (6 fold increased risk).
2. Use of IUCD's (3-5% increased risks)
3. Smoking (2.5% increased risks)
4. ART pregnancies (3-5% increased risk)
5. Tubal damage (Surgical occlusions or cilia damage).
6. Tubal Surgery (5.8% increased risk)
7. Salpingitis isthmica nodosa (3.5% increased risk)
8. Prior ectopic pregnancy (10 fold increased risk)
9. Age risk of ectopic is 3 fold greater in women of 35-44 years as compared to 18-24 years
10. Non-white race (1.5 fold increased risk)
11. Endometriosis (1.5 fold increased risk)
12. Developmental errors
13. Overdevelopment of ovum and external migration.

### Aetiology (causes)

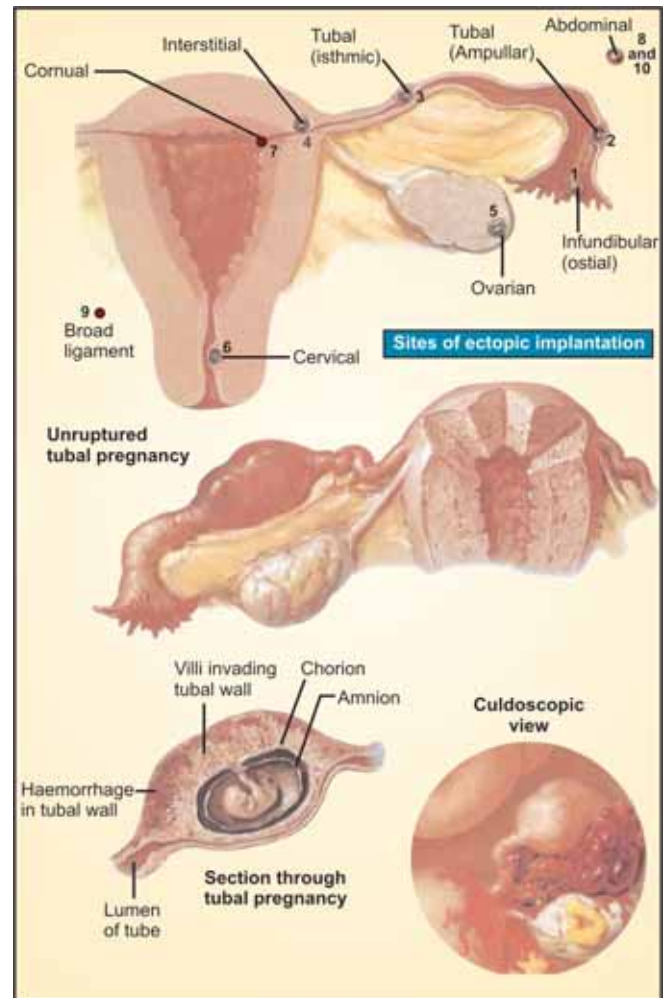
The cause of ectopic pregnancy is tubal damage or altered motility that results in the blastocyst being improperly transported and abnormally implanted. The commonest cause is acute Salpingitis in almost 50 per cent of cases. In almost 40 per cent cases no risk factor is apparent.

*Pelvic inflammatory disease:* Infection of the tubes is seen as the commonest cause preceding ectopic pregnancy and histopathological evidence of salpingitis is identified in almost 50 per cent of tubes harbouring ectopic pregnancy (Fig. 9.1).

Salpingitis causes peritubal adhesions, partial tubal lumen occlusion, intra tubal adhesions, diverticula and disturbed tubal functions.

Salpingitis (PID) may be due to Chlamydia, gonococcal infection, tuberculosis, postabortal, puerperal or secondary to pelvic peritonitis infection source could be extragenital also like appendicitis (20% cases may give history of previous surgery, usually appendicectomy).

Since tubal disease is nearly always bilateral, there is a strong tendency for ectopic pregnancy to occur first on one side and then at a later date on the other. In a woman who has already had one tubal pregnancy, the risk of a



**Fig. 9.1:** The sites of ectopic pregnancy. (1) Fimbrial (2) Ampullary (3) Isthmic (4) Interstitial (5) Ovarian (6) Cervical (7) Cornual-rudimentary horn (8) Secondary abdominal (9) Broad ligament (10) Primary abdominal - a disputed site, but see the text

second is 7 to 13 times greater than the overall risk. The aetiological influence of faulty tubes is also shown by the fact that ectopic pregnancy is often preceded by several years of infertility. The incidence of ectopic pregnancy in women previously investigated for infertility is two-and-a-half times the normal.

### Use of IUCD's

Tubal pregnancy is more likely in women using IUCD (some studies are contrary to this). IUCD prevent intrauterine pregnancy hence the ratio of ectopic to intrauterine pregnancies is much higher. Ectopic

pregnancy is more likely with progesterone IUCD rather than copper IUCD's. Copper has a phagocytic effect and a toxic effect on sperms, oocytes and embryo. Progesterone devices may alter tubal motility and polarity and hence lead to abnormal implantation.

### Smoking

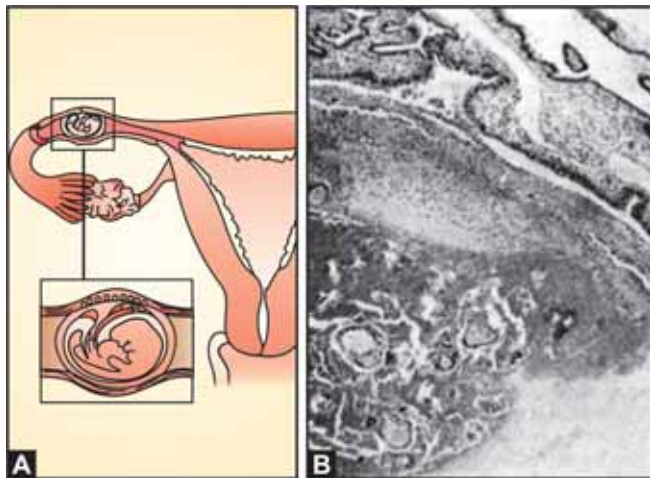
Cigarette smokers who smoke more than 20 cigarettes per day may have a relative risk of 2.5 times compared to non-smokers, while those who smoke 1 to 10 cigarettes have a relative risk of 1.3. Nicotine is thought to alter tubal motility, ciliary activity and blastocyst implantation.

### Assisted Reproduction Techniques

There is a higher incidence of ectopic pregnancy after *in vitro* fertilisation (IVF). These may be the result of direct injection of embryos into the fallopian tube, retrograde propulsion by uterine contraction, and pre-existing tubal damage. The position of the catheter in the uterine cavity and the volume of transfer medium may also be risk factors. Cauterisation of the cornual ends of the tubes was practised earlier to decrease this risk. However, this does not eliminate the possibility of an interstitial pregnancy.

### Surgical Obstruction (Tubal damage)

The fertilised ovum sometimes implants on the stump of a tube after partial salpingectomy. Tubal pregnancy



**Figs 9.2A and B:** (A) Tubal pregnancy, (B) A photomicrograph showing chorionic villi and blood alongside the endosalpinx

is also recorded after tubal ligation, and after hysterectomy with conservation of the tube, when the operation is performed within 48 hours of coitus. In such a case, the surgeon unwittingly imprisons the ovum. Tubal pregnancy is also more likely in case of sterilisation failures, these being commonest within 2 years of sterilisation and more often with cauterisation procedures than with conventional mini-laparotomy.

Abnormalities of the two agents which normally propel the ovum into the uterus represent developmental anomalies or the results of previous infection.

### Tubal Surgery

Ectopic pregnancy is seen following surgery for blocked tubes and reversal of sterilisation. The risk depends on the method and site of ligation, residual tube length and adhesions, and is also higher following cauterisation procedures.

### Salpingitis Isthimica Nodosa

This is a condition seen in chronic infections like tuberculosis and in this the tubal epithelium extends into the myometrium and forms a true diverticulum where the blastocyst is likely to implant.

### Prior Ectopic Pregnancy

Women who have had one ectopic pregnancy are likely to have a 10 fold increased risk of having an ectopic pregnancy again, even after a surgical removal of tube has been done in the first instance. This risk is due to the fact that PID and salpingitis is a bilateral disease and the risk factor will be same for other side even after ectopic on one side.

**Age:** It has been observed that older age group women (35-44 years) are at a 3 fold increased risk of an ectopic pregnancy as compared to younger women (18-24 years). This may due to the fact that older the age, more likelihood of a chromosomally abnormal blastocyst and more likelihood of this abnormal embryo implanting at an abnormal site.

**Non-white race:** Asians, blacks and other non-white race have a slightly higher risk of having an ectopic pregnancy.

**Endometriosis:** Endometriosis of fallopian tubes leads to a patchy differentiation of endosalpinx into endo-

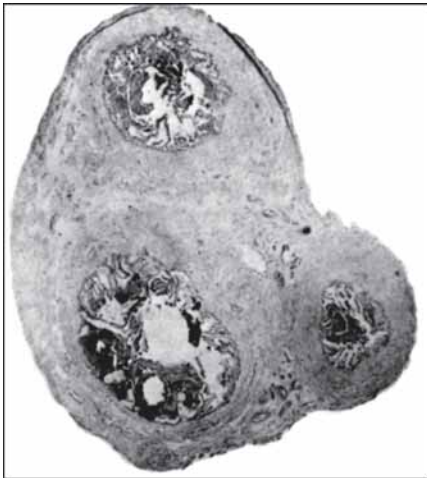
metrium and this may provide as a site for implantation. Adhesions and faulty transport within tube may also be a reason.

### Developmental Errors of the Tube

Rarely the fallopian tube may show developmental errors such as hypoplasia undue tortuosity, undue length, diverticula accessory lumen. These may trap the travelling embryo and impede its progress leading to a faulty implantation.

### Overdevelopment of the Ovum—External Migration of the Ovum

An ovum discharged from one ovary can be fertilised in the peritoneal cavity and cross the pelvis by a process of *external migration* to enter the tube on the opposite side. Meanwhile, its early development has proceeded to such an extent that it may be too big to pass the isthmic portion of the tube or, more important, it has acquired its trophoblast which encourages its implantation before it reaches the uterus. The phenomenon is not rare and is evidenced by the finding of the corpus luteum in the ovary on the side opposite to that of the tubal pregnancy. External migration is assumed in such cases but, bearing in mind how rare is conception in the woman with only one tube and only one ovary, those being on opposite sides, I often wonder whether the migration is sometimes *internal* rather than external, that is, from one tube to the



**Fig. 9.3:** An early ectopic pregnancy in a diverticulum of the fallopian tube. The cross-section of the tube shows the normal lumen at the top with accessory lumina below. Of the latter, the left one contains blood and chorionic villi. Both the diverticula had blind ends, as was established by serial sections

other across the uterine cavity. That this can occur is reliably reported.

## ECTOPIC PREGNANCY IN FALLOPIAN TUBES

### Sites

Excluding tubal ‘stump pregnancy’ the ovum implants in one of four main positions (Fig. 9.1).

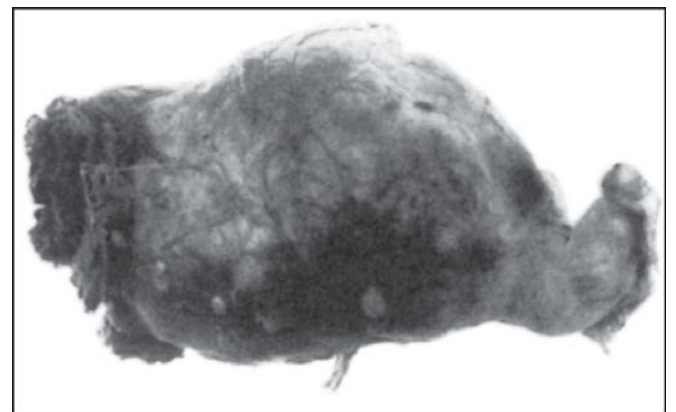
- *Fimbriated opening:* A primary implantation at this site is unusual (17%) (Fig. 9.4).
- *Ampulla:* This is the commonest and least dangerous site (55%) (Fig. 9.5).
- *Isthmus:* This is less common but is more dangerous because of the likelihood of tubal rupture (25%).
- *Interstitial:* This is probably rare although some cases may be missed because the pregnancy can be discharged through the uterus: it is said to be the site in 3 per cent of all tubal pregnancies.
- Diverticulum of fallopian tube (Fig. 9.3).

### Reactions of the Tube

The ovum burrows into the tube as it does into the uterus and, in so doing, induces a decidual reaction in the cells of the endosalpinx. This reaction is patchy, feeble and relatively ineffective in controlling the invasion of the trophoblast into the tube wall and blood vessels. The muscle undergoes only limited hypertrophy so, for one or both reasons, there is a high risk of choriodecidual haemorrhage and of erosion or rupture of the tube wall.

### Reactions of the Uterus

The uterus itself is under the influence of the hormones of the corpus luteum and of the trophoblast, so it



**Fig. 9.4:** An unruptured tubal pregnancy situated near the fimbriated extremity

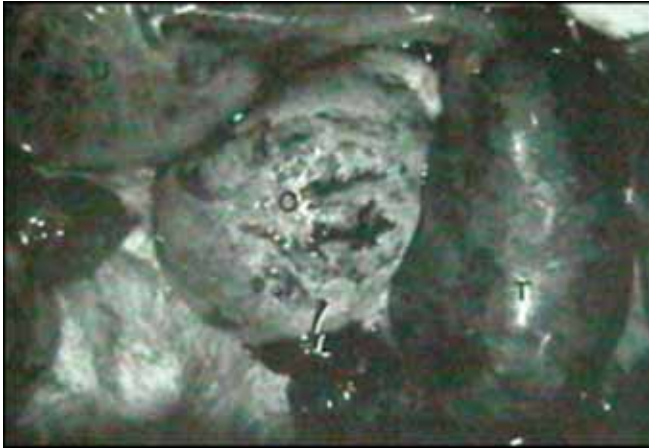


Fig. 9.5: Ampullary ectopic pregnancy

responds by generalised enlargement, increased vascularity, hypertrophy of all tissues, and decidual reaction in the endometrium.

A special appearance of the endometrial glands (the *Arias-Stella reaction*) is seen in 10-15 per cent of cases. This is characterised by a mixed pattern of atypical proliferative and secretory activity, the epithelial cells being enlarged and having hyperchromatic and gigantic bizarre-shaped nuclei which are sometimes polypoidal. Their cytoplasm can be vacuolated and foamy. These histological features, which, except for the secretory activity, are rather suggestive of malignant change, represent an unusual response to steroid hormones and are not, as was once thought, peculiar to ectopic pregnancy. They can sometimes be found in association with normal early intrauterine pregnancy, abortion, hydatidiform mole, choriocarcinoma, endometriosis, and after prolonged intake of oestrogens and progestogens.

The decidua is maintained until some accident overtakes the pregnancy when it separates and is discharged from the uterus, either as a whole cast or in fragments (Figs 9.6 and 9.7). Decidual separation is accompanied by slight continuous uterine bleeding, the mechanism so far as the vascular apparatus is concerned being the same as in menstruation. Prior to this, and while the pregnancy is alive, the patient is amenorrhoeic.

### General Reactions

The woman responds to pregnancy in the usual way and may experience nausea, vomiting, changes in appetite, and pain and tenderness in the breasts.

### Discharge of the Ovum Into the Lumen of the Tube—Tubal Abortion

*Tubal abortion:* When the pregnancy is implanted in the fimbrial end (17%), this will separate from its attachment to the tube and its trophoblastic shell and this could lead to complete absorption, complete abortion, incomplete abortion or missed abortion (tubal mole).

*Complete absorption:* Difficult to prove as very small embryo may abort in peritoneal cavity and get absorbed without any signs and symptoms.

*Complete abortion:* The embryo is expelled out of the fimbrial end by tubal contractions into the peritoneal cavity. This may occur with only slight bleeding (Asymptomatic or mild symptoms) and may later get absorbed. Complete abortion may also lead to continuous bleeding and haemoperitoneum and shock like symptoms.

### Pregnancy Outcome

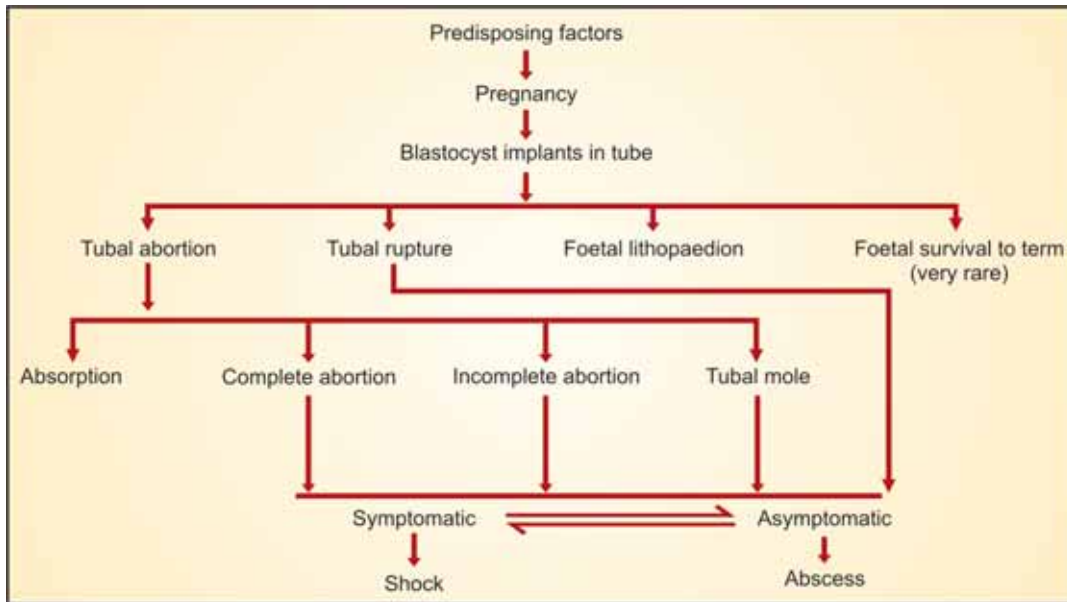
The tube is capable for only limited distention and is unable to provide secure placentation also due to the unsatisfactory environment, 80 per cent of these embryos are malformed and more than 99 per cent of these pregnancies do not progress beyond 6 weeks. The course of pregnancy is illustrated in the flow chart 9.1. Usually this condition will lead to a disaster in one of the following ways:

1. Tubal abortion
2. Complete absorption
3. Complete abortion
4. Incomplete abortion
5. Missed abortion (Tubal Mole)
6. Tubal rupture
7. Chronic ectopic adnexal mass
8. Foetal survival to term.

*Incomplete abortion:* Some of the products of conception one expelled out of fimbrial end. Usually bleeding continues and condition is symptomatic.

*Missed abortion (Tubal Mole):* The embryo dies due to faulty environment and faulty implantation and is converted into a carneous mole. Usually will get partially absorbed and liquified and give rise to a symptomless haematosalpinx. Or the process may progress leading to haematosalpinx, peritubal haematocele and even pelvic haematocele.

Flow chart 9.1: Course of ectopic pregnancy



The haematocele if asymptomatic and not treated will form a pseudo false capsule around the organised blood and lymph. Later it will lead to adhesions to omentum, bowel uterus, pelvic peritoneum and ultimately it will get infected and form pelvic abscess.

### Tubal Rupture

The fallopian tube may rupture due to its thin lumen at isthmus and ampulla. The lumen is incapable of distension due to the blastocyst burrowing and eroding the tubal wall.

Rupture of tubes usually cause severe bleeding and complete or partial extrusion of chorionic villi leading to a haemodynamic unstable patient presenting with shock like features.

The rupture is usually intraperitoneal leading to pelvic and peritoneal haematocele.

Rarely rupture may be extraperitoneal, if rupture is at broad ligament attachment such a condition will present as broad ligament haematoma pelvic haematoma. Ultimately the broad ligament haematoma will either rupture intraperitoneal or form an abscess.

### Chronic Ectopic Adnexal Mass

Sometimes the products of conception are partially extruded through the fimbria or through a partial

rupture. After a slight or mild to moderate bleeding the haemorrhage may get arrested and result in a adnexal mass involving the tube, ovaries and clots. This may present as chronic pelvic pain in many women.

### Foetal Survival to Term

The foetus usually does not develop beyond 6 weeks in the fallopian tubes however in rare conditions pregnancy may progress and foetal death occurs later with formation of calcified lithopaedion which may even be detected many years later as expulsion of foetal bones through rectum, bladder, pouch of Douglas or in abdominal cavity.

Very rarely pregnancies have been known and reported to have survived upto term in abdominal cavity (secondary abdominal pregnancies). The chorionic villi and placenta have been reported to get implanted in broad ligament, bowel, omentum, liver surface and even diaphragm. Such pregnancies have a poor foetal outcome (80% do not survive) and also have a 20 per cent chance of maternal mortality due to haemorrhage.

### Clinical Features

Tubal pregnancy presents as a chronic or an acute illness, or as an acute-on-chronic. *The first is much more common* but the acute picture is so dramatic that it tends to receive more attention.

### Symptoms and Signs

1. Normal symptoms and signs of pregnancy (amenorrhoea and uterine softening)
2. Acute Abdominal pain (dull, crampy or colicky pain)
3. Evidence of haemodynamic instability (hypotension, collapse, sign and symptoms of shock)
4. Adnexal mass (with or without tenderness)
5. Vaginal bleeding
6. Signs of peritoneal irritation
7. Absence of gestational sac on ultrasound with a  $\beta$ -HCG of  $\geq 2500$  mIU/ml
8. Abdominal pregnancy.

### Chronic Ectopic Pregnancy

This is seen when intraperitoneal bleeding from the tube is small in amount but recurrent, as in tubal abortion and tubal mole.

The patient has a *short* period of amenorrhoea and sometimes notices other symptoms of early pregnancy such as nausea and breast pain. When a menstrual period is overdue by a few days (that is, when the pregnancy is only 2-3 weeks old), distension or contractions of the tube may cause aching in one or other iliac fossa. This is not so noticeable, however, as are attacks of sharp stabbing pain caused by choriodecidual haemorrhages or by the escape of blood into the peritoneal cavity. The severity of pain depends on the amount of blood lost and there is *nearly always an associated syncope*. The latter varies from

a momentary feeling of faintness to collapse and unconsciousness, but a combination of pain and syncope is the most constant and characteristic symptom of ectopic pregnancy. Many published analyses of symptoms put syncope relatively low on the list, but this is because the analyses are made retrospectively on incomplete records in which no attention is paid to slight faintness. When the patient lies down, the blood tracks to the diaphragm and this is manifested by shoulder tip pain, or by epigastric pain which is worse on inspiration.

Slight vaginal bleeding follows lower abdominal pain and this is easily mistaken for the late onset of a menstrual period. It is uterine in origin and indicates separation of the decidua although some authorities consider that, in part at least, it comes from the affected tube. Once this bleeding has begun it tends to continue (if only as a brown discharge) *without intermission*; this is a diagnostic feature. A decidual *cast* may be recognised in the discharge (Fig. 9.6). A large pelvic haematocele (Fig. 9.7) can cause acute retention of urine as a leading symptom. The collection of blood in the pouch of Douglas can also mean that the patient finds it difficult to sit on a hard chair without some ill-defined discomfort.

Examination may or may not reveal early pregnancy changes in the breasts. *Tenderness and muscle guarding over the lower abdomen*, especially on the affected side, is a striking feature. The amount of blood in the peritoneal cavity is unlikely to be sufficient to give rise to signs of free fluid, but some degree of intestinal distension is a

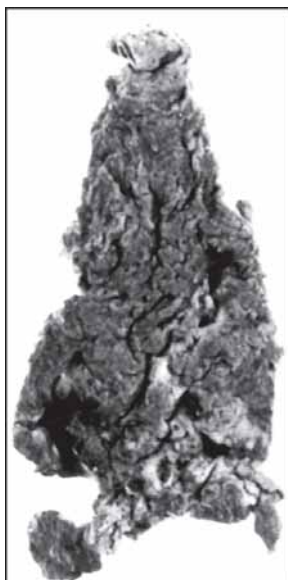


Fig. 9.6: Decidual cast from a case of ectopic pregnancy



Fig. 9.7: Ruptured ectopic with haemoperitoneum

common and an important diagnostic sign. Haemoperitoneum of 2 or 3 weeks' standing can cause the appearance of bruising around the umbilicus (Cullen's sign). It is rarely seen nowadays in ectopic pregnancy but I have found it to be the clue to the diagnosis of haemoperitoneum due to other lesions.

The possible findings on vaginal examination include: arterial pulsation in the fornix on the affected side; an irregular and *tender* enlargement of the adnexum on the affected side; and an ill-defined *tender* semi-solid swelling in the pouch of Douglas, indicative of pelvic haematoma. Tenderness in the pelvis is the most constant sign.

The patient looks pale and the pulse rate is likely to be raised, especially after an attack of pain. It is also not uncommon to find slight intermittent pyrexia - the effect of absorption of products of degenerated blood. The bilirubin content of the blood is increased and the patient may ultimately become jaundiced. In the ordinary case, there is a slight rise in the leucocyte count and in the erythrocyte sedimentation rate. A long-standing haemoperitoneum, however, can cause a high leucocyte count; this, in association with a low haemoglobin level, is a diagnostic point.

### Acute Clinical Picture

This is seen when there is a sudden massive intra-peritoneal haemorrhage (Fig. 9.7) and is typical of tubal rupture rather than tubal abortion. It may supervene on a previously chronic picture.

After a *short* period of amenorrhoea, and sometimes none, the patient is seized with a severe lancinating pain in one iliac fossa or in the hypogastrium. This is immediately followed by profound collapse marked by pallor, low blood pressure, subnormal temperature and a weak rapid pulse. Death may ensue in a very short time. Usually, however, the haemorrhage is temporarily arrested and the general condition improves within a few hours. Pain persists, however, and is referred to the epigastrium or the shoulder.

Examination reveals obvious signs of shock and anaemia. The lower abdomen (and sometimes the upper as well) is usually acutely tender. The presence of free blood in the peritoneal cavity may be indicated by dullness in the flanks and intestinal distension in front. *Vaginal examination should not ordinarily be carried out for fear of precipitating more bleeding but if it is (and it*

*should be very gentle), some enlargement of one adnexum may be detected. This sign is not easy to elicit because of tenderness. Again, acute tenderness and the production of pain by movement of the cervix are the leading signs.*

### Classical Triad

A patient with amenorrhoea, pain and vaginal bleeding should always be suspected to have an ectopic pregnancy. The dictum to early diagnosis and successful management is to "THINK ECTOPIC" but also not to "OVER THINK ECTOPIC".

### Differential Diagnosis

All women in reproductive age group complaining of the classical triad or any one of the three symptoms should raise the suspicion of ectopic pregnancy even through the patient is on an effective contraception or even has had a tubal occlusion operation.

The picture of ectopic pregnancy is extremely variable and can mimic any intra-abdominal disease. It should be kept in mind here that:

1. 85-90 per cent patients have abdominal pain
2. 80-85 per cent have amenorrhoea
3. 80-85 per cent have vaginal bleeding

In ectopic pregnancy the clinical diagnosis is more on symptoms rather than signs (Negative physical signs should not be allowed to over rule symptoms).

The following conditions are most likely to be confused with ectopic pregnancy. These may be pelvic diseases or non-gynaecological non-obstetric diseases.

- A. Obstetric diseases
  - i. Abortion of an early intrauterine pregnancy
  - ii. Abortion followed by salpingitis
  - iii. Early pregnancy with pelvic Tumours
  - iv. Retroverted gravid uterus (Threatened abortion)
  - v. Septic abortion
- B. Gynaecological diseases
  - i. Degenerating fibroid
  - ii. Dysfunctional uterine bleeding
  - iii. Endometriosis
  - iv. Ovulation (Mittelschmerz)
  - v. Ruptured corpus luteum
  - vi. Torsion of adnexal mass
  - vii. Acute or subacute salpingitis (including tuberculosis)
  - viii. Dysmenorrhoea

C. Non-gynaecological conditions

- i. Appendicitis
- ii. Gastroenteritis
- iii. Mesentric thrombosis
- iv. Perforated peptic ulcer
- v. Renal colic
- vi. Intraperitoneal haemorrhage from any source (Rupture splenic aneurysm/tumours).

**Diagnosis**

Mostly the diagnosis is based on the classical clinical triad of pelvic pain, vaginal spotting and amenorrhoea (5-9 weeks).

Other classical symptoms are dizziness, pregnancy symptoms and vaginal passage of clot/tissue. The most common classical finding is adnexal tenderness and adnexal mass.

Ruptured ectopic may present as shock (tachycardia with hypotension). Shoulder pain due to diaphragmatic irritation is a late sign of haemoperitoneum.

**Tests and Aids to Diagnosis**

1. *Urine pregnancy test*: Is positive in about 50 per cent of cases (A negative test is seen in cases due to dead chorionic tissue or disruption of connection of ectopic to maternal circulation).
2. *β-hCG levels*: In ectopic pregnancy the production of β-hCG is less as compared to normal pregnancy. A subnormal rise in β-hCG in early pregnancy (<66% in 48 hours) suggests pregnancy is not viable (early pregnancy failure or ectopic pregnancy). β-hCG is an important hormone to follow serially. It should also be kept in mind that transvaginal sonography should detect a gestational sac in nearly 100 per cent pregnancies when β-hCG level exceeds 2400 mIU/ml in serum.
3. *Serum progesterone*: Also may be helpful as an adjunct to β-hCG in evaluating ectopic pregnancy. A progesterone level of greater than 25 ng/mL is associated with an intrauterine pregnancy in 97.5 per cent.

*Ectopic Finding/Heterotrophic (Colour Doppler)*

4. *Transvaginal ultrasound* is a valuable diagnostic tool. The presence of an intrauterine pregnancy generally excludes ectopic pregnancy (Heterotrophic ectopic should be kept in mind).

The discriminatory zone is the level of serum β-hCG greater than 2400 mIU/ml. A gestational sac is visualised in almost 100 per cent cases at a β-hCG level above discriminatory zone (with use of transabdominal ultrasound the value of discriminatory zone is 6500 mIU/ml).

Transvaginal ultrasound findings may be classified as uterine findings or extra uterine findings.

*Uterine Findings (Fig. 9.8)*

- i. Empty uterus
- ii. Thickened endometrium
- iii. Pseudogestational sac

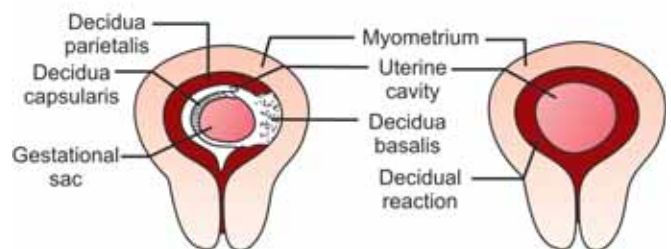
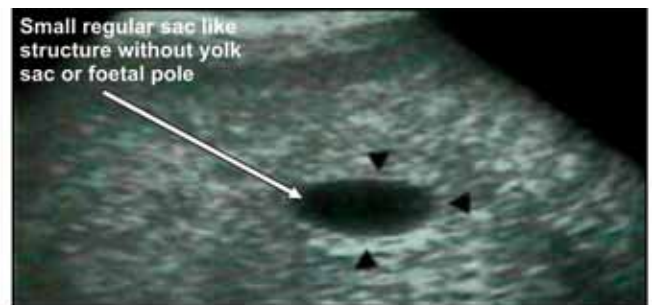
*Extra Uterine Findings (Fig. 9.9)*

- i. No findings (Fig. 9.9D)
- ii. Live tubal pregnancy (Fig. 9.9A)
- iii. Adnexal ring sign (Figs 9.9B and 9.10)
- iv. Complex adnexal mass (Figs 9.9C and 9.11)
- v. Free fluid in pouch of Douglas

Colour doppler will classically identify “ring of fire” around the ectopic on the same side as corpus luteum. The blood flow is low resistant trophoblastic flow pattern (Fig. 9.12).

5. Other Placental Markers:

- i. Serum creatine kinase levels (CK)
- ii. Pregnancy specific β (1) - glycoprotein (sp1)
- iii. Human placental Lactogen (HPL)
- iv. Pregnancy associated plasma proteins (PAPP-A).



**Fig. 9.8:** Uterine findings of pseudosac



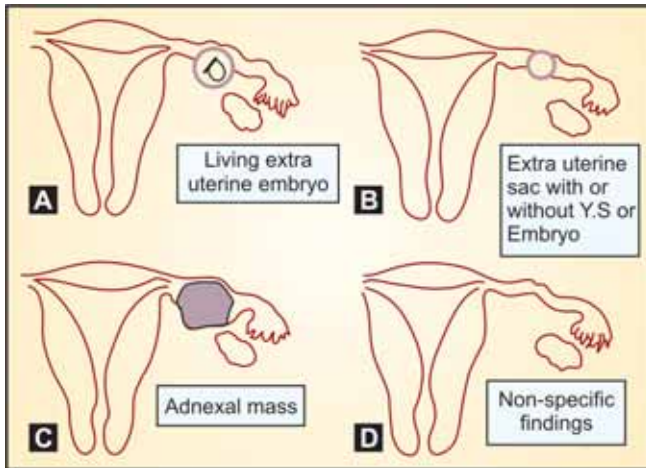


Fig. 9.9: Adnexal findings (Extra uterine findings)



Fig. 9.12: Colour doppler findings

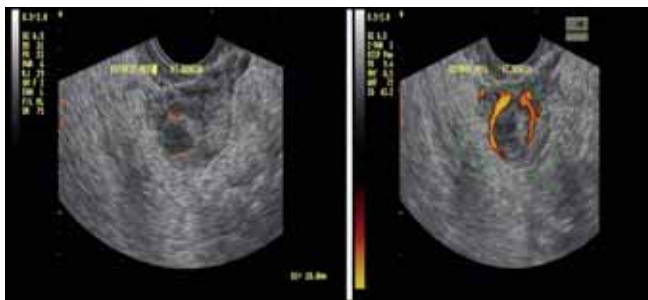


Fig. 9.10: Adnexal ring sign

Neither of the markers (increased CK, decrease SP1, HPL or PAPP-A) can exclude ectopic from early pregnancy.

A combination (triple marker test) in a computed formula may be helpful VEGF/PAPP-A × P (Vascular endothelial growth factor, progesterone and pregnancy associated plasma proteins)

- v. Serum IL-8, IL-6 and TNF $\alpha$  concentrations also increased in women with ectopic.
- vi. Cancer Antigen 125 (CA 125) is not specific but may indicate pregnancy failure.

6. Pelvic Examination Under GA and Culdocentesis (Culdotomy/Posterior Colpotomy)

Examination under GA to determine presence of an adnexal mass has no place in modern management of ectopic pregnancy. It is potentially dangerous and may result in rupture and haemorrhage.

A culdocentesis to determine presence of blood in pouch of douglas is unreliable and has no role in modern management with ultrasound and laparoscopy.

7. Laparoscopy: A laparoscopic confirmation of diagnosis is useful.

8. Curettage: A diagnostic curettage will identify chorionic tissue in the curetted material (floatation test, look under microscope for villi and histo pathological examination).

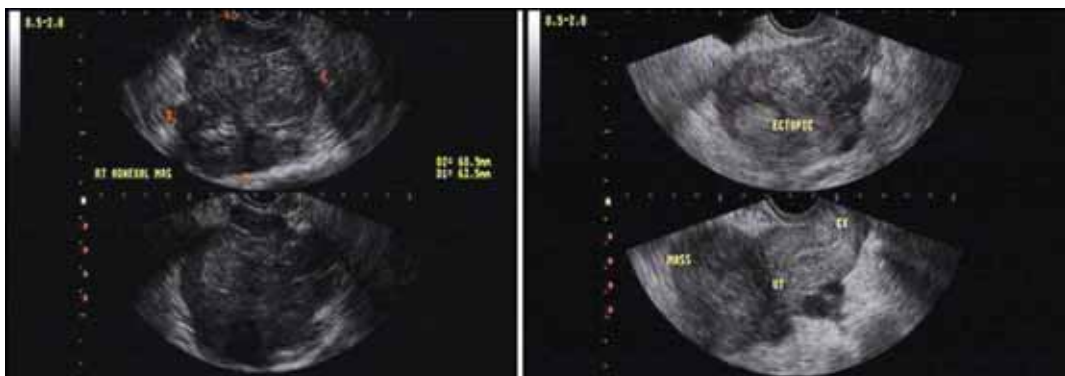


Fig. 9.11: Complex adnexal mass

Identification of only decidua in histopathology (Arias - Stella reaction) is suggestive not diagnostic.

Today dilatation and curettage for diagnosis is seldom used, with the availability of more accurate methods.

9. *Other laboratory tests:* A complete blood test (haemogram and CBS and blood grouping and typing) All other routine blood tests should be done. A high ESR may suggest tubercular salpingitis in cases of unruptured ectopic pregnancies. Diagnostic Laparoscopy is reserved and indicated if patient is stable, shows a subnormal rise of  $\beta$ -hCG and ultrasound has not been able to detect and diagnose ectopic. The advantage with laparoscopy is that if diagnosed, ectopic pregnancies can be safely operated at the same sitting hence saving a laparotomy.

Today operative video laparoscopy has revolutionised the surgical management of ectopic and will prevent over 40 per cent laparotomies overall. Good equipment and surgical skill is required for laparoscopic surgery.

### Management and Treatment Options

In all cases of suspected ectopic pregnancy, the patient should be admitted in the hospital. Shock must be treated before she is moved.

For treatment options, the management will depend on:

1. Condition of patient (Haemodynamic stability)
2. Acute ruptured ectopic
3. Chronic ectopic
4. Unruptured early ectopic
5. Unruptured dieing ectopic
6. Ectopic in places other than fallopian tubes (cervical, abdominal, ovarian, interstitial, uterine scar).

Surgical or medical management will depend on the above factors.

### Laboratory Tests

These include a white cell count and an erythrocyte sedimentation test, which may help to distinguish between ectopic pregnancy and conditions such as salpingitis.

### Treatment

Whenever tubal pregnancy is diagnosed or suspected, the patient should be admitted to hospital *immediately*,

provided that she is not in a state of shock. Shock must be treated before she is moved.

### Treatment of Shock

Lay the patient flat, keep her still and quiet, and give morphine or pethidine. With these simple measures alone, and *so long as no vaginal examination is made to confirm the diagnosis and to cause more haemorrhage*, the general condition usually improves. Transfusion with blood, plasma or substitutes should be arranged as soon as possible, if need be in the patient's home.

### Surgical

Laparotomy is called for as soon as the diagnosis of ruptured ectopic pregnancy is made and the patient is in hospital. Blood transfusion may be required before, during and after operation, but operation must not be deferred until the woman is in good condition. Resuscitation and operation at the same time can be life-saving. Immediate laparotomy and clamping of the bleeding vessels may be the only means of saving the life of a moribund patient. When donated blood is not available, an autotransfusion of blood, ladled from the peritoneal cavity and filtered through gauze, gives excellent results. But it must be fresh and not old blood.

Before deciding the surgical treatment of the affected tube, *the opposite tube and ovary should be examined*; the procedure should then take account of the patient's age and future reproductive capacity as well as the nature of the lesion. The importance of this was illustrated by the case of a doctor's wife whose first pregnancy was in the right tube. The gynaecologist operated and noted that the left tube was rudimentary and functionless, and the uterus almost unicornuate. He therefore carried out right-sided salpingotomy. The state of affairs was confirmed at subsequent caesarean section. This woman now has three children, thanks to the gynaecologist who examined the left tube first.

### Salpingotomy

If the patient has an unruptured ectopic pregnancy and wishes to retain her fertility, linear salpingotomy is the procedure of choice. An incision is made over the distended segment of the tube using needle-tip cautery, laser, scalpel or scissors, and the products of gestation removed. The tube is irrigated well to remove all trophoblastic tissue and ensure haemostasis. The

procedure can be done by laparoscopy or laparotomy with equally good pregnancy rates subsequently. A segmental resection with primary microsurgical re-anastomosis has also been advocated but has the same results as linear salpingotomy and the latter is an easier and shorter procedure. Milking the pregnancy through the abdominal ostium (transfimbrial extraction) has been advocated in the past if the haemorrhage is easy to control and the pregnancy is fimbrial. However, the risk of recurrent ectopic pregnancy is twice as high as that with linear salpingotomy, so this procedure is now obsolete.

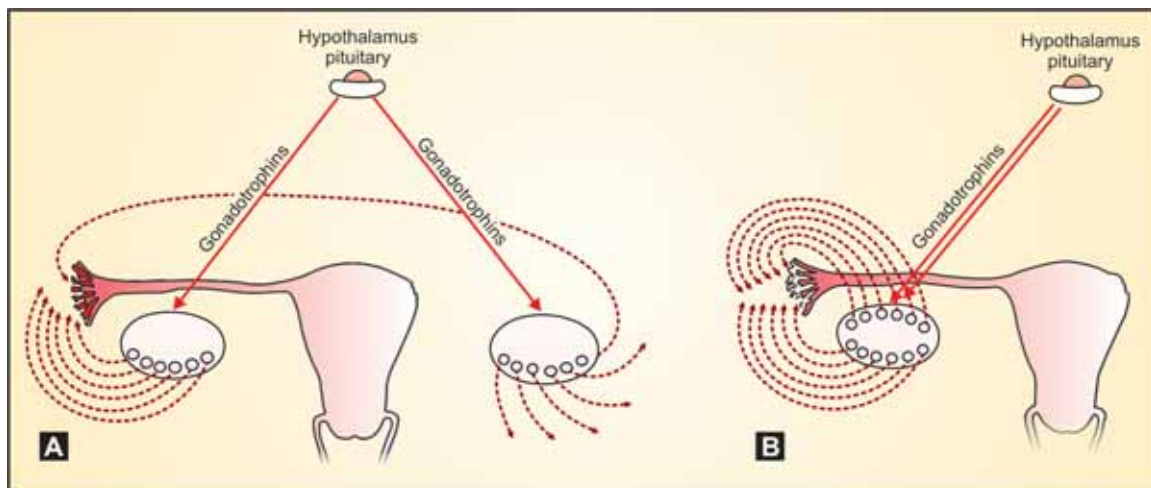
#### *Salpingectomy and Salpingo-oophorectomy*

Removal of part or all of the affected tube is the usual procedure, if the patient has completed her family, if the tube appears to be grossly damaged, or if ectopic pregnancy has recurred in a tube already treated conservatively. In the case of interstitial pregnancy, the cornu of the uterus is excised as well. In practically all cases, the ovary can be conserved even though the surrounding blood clot makes it at first look beyond hope. The advantage of saving the ovary is conservation of its endocrine function. Portions of the removed tube should always be examined histologically and *bacteriologically for tuberculosis*.

Failure to conceive again after a tubal pregnancy is sometimes voluntary but is also to some extent explained

by abnormality of the other tube. Professor Jeffcoate postulated that *unilateral salpingectomy* reduces the chances of pregnancy by approximately one-half. When an ovum is produced by the ovary on the side from which the tube has been removed, and this is likely on an average during half the cycles, it can be fertilised and implanted only if it undergoes external migration. This phenomenon, if it ever occurs, would add to the risk of an ectopic pregnancy on the other side. If *unilateral salpingo-oophorectomy* is carried out, the chances of subsequent pregnancy are doubled because ovulation must then always take place from the ovary which still has its oviduct. It follows that in a woman who is particularly anxious about future fertility it may be better to sacrifice than to save the ovary on the affected side (Fig. 9.13).

Having started this idea in respect of the treatment of any unilateral tubal disease, Professor Jeffcoate was often accused of recommending removal of the normal ovary as well as the tube as the standard treatment of tubal pregnancy. This is not true; he did this less than 10 times in all, usually with pleasing results. Professor Tindall also did this on a similar number of occasions, based on the findings and strict observations of the principles in the preceding paragraph, which require careful study. However, the developments of *in vitro* fertilisation and embryo transfer and of microsurgery make conservation of the ovaries even more important.



**Fig. 9.13:** Jeffcoate's theory of the different effects of salpingectomy and salpingo-oophorectomy on subsequent fertility (see text). (A) After salpingectomy, approximately half the ova shed are from the ovary without an oviduct and, unless they migrate across the pelvis, are lost, (B) After salpingo-oophorectomy all the ova are produced by the remaining ovary and are available for fertilisation and passage down the tube into the uterus

Moreover, in practice, the ovaries are often found lying relatively close to each other behind the uterus and external migration is not a greatly improbable happening. *Presently, salpingo-oophorectomy is never recommended unless the ovary itself is grossly diseased or damaged.*

If culdotomy has been performed for diagnostic purposes and the affected adnexum is found easily accessible, salpingectomy or salpingo-oophorectomy can be carried out by the vaginal route. This, however, is generally to be avoided because it does not permit proper assessment of the opposite tube and ovary, nor adequate peritoneal toilet.

Before any operation is concluded, free blood and clots are removed from the peritoneal cavity. Omission to do this, on the grounds of shortening the time of operation in an ill woman, often leads to postoperative ileus and sometimes necessitates reopening the abdomen a few days later. As soon as the haemoperitoneum is cleared, the patient usually makes a remarkably rapid recovery.

Rhesus isoimmunisation can result from ruptured tubal pregnancy so, if the patient's blood group is rhesus negative and she is hopeful of further pregnancies, anti-D immunoglobulin must be administered in the immediate postoperative period.

#### Role of Laparoscopy

Salpingectomy (Fig. 9.14), salpingostomy (Fig. 9.15), segmental resection and direct injection into the sac can

all be done laparoscopically if the patient is haemodynamically stable. Blood loss is reported to be less; hospital stay and convalescence are shorter; postoperative requirements of analgesia are less; cosmetic results are better and subsequent tubal pregnancy, pregnancy and persistent trophoblast rates are similar. A ruptured ectopic pregnancy can also be managed laparoscopically, but if removal of blood clots is causing operative delay, laparotomy is preferable. Laparotomy is also preferable in cases of cornual or interstitial pregnancy. In most parts of the developing world, facilities for laparoscopy may not be available, especially in emergency settings.

#### Medical

Methotrexate is the most frequently used drug in the medical management of ectopic pregnancy; 20 per cent potassium chloride, prostaglandins, RU 486, hyperosmolar glucose, vasopressin and actinomycin have also been tried. Some have been administered intravenously, intramuscularly or orally; with others, local therapy has been tried via laparoscopic injection or ultrasound guidance.

Methotrexate was initially administered in the standard dose used for trophoblastic disease. Presently the single-dose intramuscular injection ( $50 \text{ mg/m}^2$ ) is also used. This is cheaper, has less side-effects, needs less monitoring, folinic acid rescue is not required and treatment results are comparable. Indications for methotrexate therapy include the following: no intrauterine gestation sac or fluid collection on transvaginal sonography (TVS), hCG level less than 2000

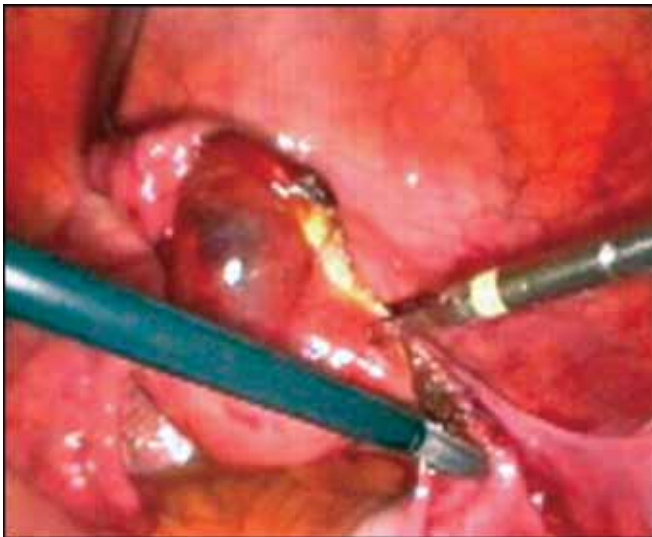


Fig. 9.14: Laparoscopic salpingectomy

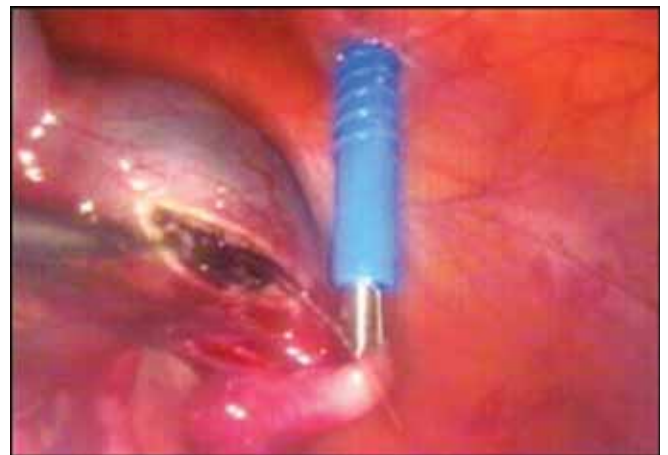


Fig. 9.15: Laparoscopic salpingostomy

mIU/ml, ectopic pregnancy mass less than 3.5 cm; or hCG is positive after salpingotomy (persistent ectopic pregnancy). Gastrointestinal, hepatic, renal and haemopoietic disease should be excluded. Patients can be followed up on an out-patient basis. If pain increases or is prolonged, TVS may be done to ensure that the tube has not ruptured. However, the fluid collection and size of the mass may increase if there is a tubal abortion. This is acceptable if the haematocrit is stable. Every 3 days, hCG levels are repeated until negative. A fall of 15 per cent between day 4 and 7 should occur, otherwise a second dose is administered. Approximately 5 per cent of cases do not respond and require surgery.

Salpingocentesis (Fig. 9.16) has been used with agents such as potassium chloride, methotrexate, prostaglandin, vasopressin, RU 486 or hyperosmolar glucose. These are instilled directly into the ectopic pregnancy sac transvaginally using ultrasound guidance or by laparoscopy. This procedure can avoid systemic side-effects but long term results are not yet known. Methotrexate is the most commonly used agent. A 2 ml solution containing 50 mg of the drug is injected directly into the sac. This method is particularly useful in cases of interstitial or cornual ectopic pregnancies where other forms of surgery carry the risk of severe haemorrhage. The criteria are the same as above. However, it is difficult to predict the patient who can have tubal rupture.

### Expectant Management

Early diagnosis of ectopic pregnancy can allow for expectant management if the symptoms are slight and subsiding, initial  $\beta$ -hCG level is less than 1000 mIU/ml, the size of the ectopic pregnancy is less than 2 cm on TVS and the haemoperitoneum is less than 50 ml.

Nearly two-thirds of patients will undergo spontaneous resolution within 3-5 weeks. Regular monitoring with estimation of hCG levels and ultrasound is required. Results of subsequent fertility are presumably as good, but assessment of larger groups is awaited.

### OVARIAN PREGNANCY

Ovarian pregnancy is very rare, many apparent examples being explained by an extruded tubal pregnancy becoming adherent to the surface of the ovary. In true ovarian pregnancy, the ovum is fertilised while it is in the abdominal cavity, in the graafian follicle or in the process of leaving the follicle. The pregnancy then develops within a capsule of ovarian tissue with the corpus luteum immediately alongside it (Fig. 9.17).

Endometriosis on the surface of an ovary is said to favour implantation of an ovum fertilised in the peritoneal cavity.

The criteria for a diagnosis of ovarian pregnancy are: the tube and its fimbriae are normal and separate from

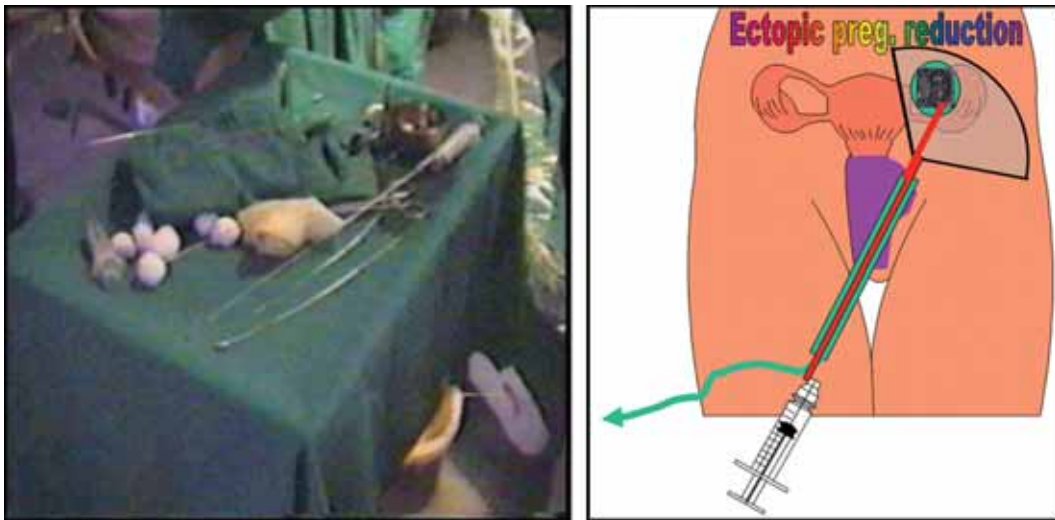
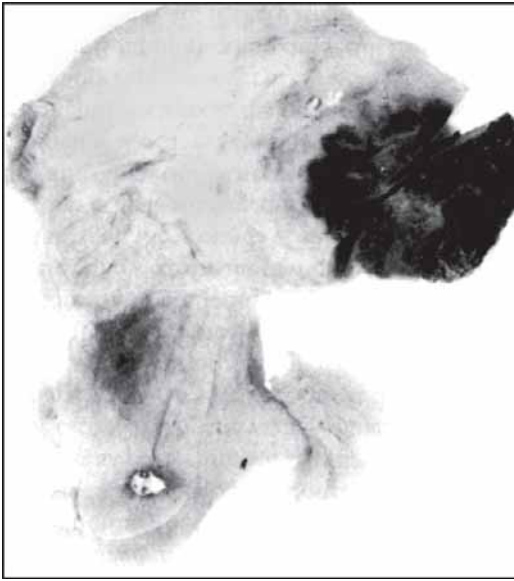


Fig. 9.16: Local injection of methotrexate



**Fig. 9.17:** Ovarian pregnancy with the outer end of a normal tube above

the pregnancy sac; the pregnancy sac is in the position of the ovary; the pregnancy sac is attached to the uterus by the ovarian ligament; ovarian tissue is histologically recognisable in several areas of the wall around the pregnancy. These criteria are generally attributed to Spiegelberg.

### Pathology

The general and local reactions of the body are the same as in tubal pregnancy. Decidual reaction occurs in the endometrium and, to a limited extent, in the stroma of the ovary. The ovary can only accommodate the pregnancy for a very short period; within 2-3 weeks the capsule bursts or is eroded and is the source of intra-abdominal haemorrhage.

### Clinical Features; Differential Diagnosis

These are the same as for tubal pregnancy, and an ovarian site for the pregnancy is usually unsuspected before laparotomy. At operation the conditions likely to be confused are: haemorrhage from the corpus luteum of menstruation or of pregnancy; ovulation haemorrhage; and haemorrhagic cysts of all kinds. These are often only distinguished by histological examination of removed tissues.

### Treatment

The principles of treatment are the same as for tubal pregnancy. At operation the affected ovary usually has to be sacrificed.

### CORNUAL PREGNANCY

In this rare form of ectopic pregnancy implantation occurs in the cavity of a rudimentary horn of the uterus. The horn does not always communicate with the rest of the uterine cavity in which case it must be assumed that spermatozoa ascend through the other horn and tube and fertilise an ovum in the peritoneal cavity. This then enters the tube of the rudimentary horn.

### Pathology

The general and local reactions are the same as for tubal pregnancy. An important feature of cornual pregnancy, however, is that the sac is surrounded by myometrium and, even though this is poorly developed, it can contain the pregnancy for a longer time than can the tube or ovary. Rupture of the horn therefore does not usually take place until the twelfth to the twentieth week but, when it does, there is nearly always severe bleeding which makes the condition extremely dangerous.

In some respects, cornual pregnancy resembles the interstitial type of tubal pregnancy and they can be confused at operation. A distinguishing feature is *the insertion of the round ligament which is always lateral to a cornual pregnancy*. In both cases it is possible for the pregnancy to be discharged into the main cavity of the uterus.

### Clinical Features; Differential Diagnosis

These are similar to those of tubal gestation except that dramatic symptoms occur late. Before the occurrence of rupture the condition most likely to be confused is a painful leiomyoma complicating pregnancy. The pregnant horn differs from a myoma in that it can be *felt to contract*.

Asymmetrical enlargement of the uterus, real or apparent, is a feature of normal early pregnancy. If exaggerated, an implantation of the conceptus into the cornu of a normal uterus is sometimes postulated and the condition called an *angular pregnancy*. The asymmetry disappears by the twelfth week but, meanwhile, might be confused with a cornual pregnancy.

## Treatment

This is governed by the principles described under tubal pregnancy, the affected horn together with the pregnancy being usually removed.

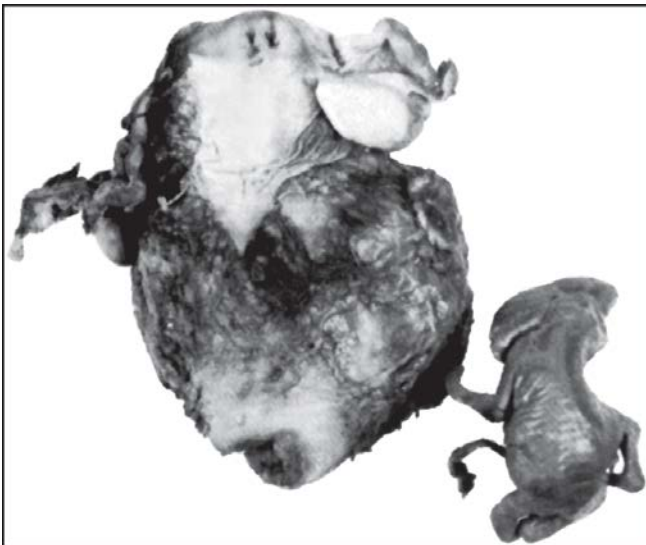
## CERVICAL PREGNANCY

This rare form of ectopic pregnancy is one in which the ovum becomes implanted in the cervical canal and distends it as it grows.

Clinical criteria for diagnosis of cervical pregnancy are: the uterus above the distended cervix is smaller; the internal os is closed; no placental tissue is obtained on endometrial curettage; the external os opens earlier than in spontaneous abortion.

Ultrasound criteria have been described to differentiate a true cervical pregnancy from a spontaneous abortion. These include: empty uterine cavity or a false gestation sac; hour-glass uterine shape; ballooned cervical canal containing the gestation sac and placental tissue; closed internal os. Magnetic resonance imaging has also been used to establish the diagnosis.

The condition can be mistaken for an incomplete abortion of a normally sited pregnancy, placenta praevia or, if the external os is not dilated, for a cervical leiomyoma or cervical carcinoma.



**Fig. 9.18:** A cervical pregnancy with a small misshapen foetus still attached to its placenta within the pregnancy sac. The latter is in the supravaginal cervix and bulging out into the right broad ligament. The external os is visible at the lower pole. As is usual, the bleeding in this case was so severe and uncontrollable that hysterectomy was necessary

Abortion usually takes place sooner or later and, when it does, bleeding from the non-retractile cervix can be so severe as to necessitate hysterectomy (Fig. 9.18). Continuance of the pregnancy to produce a viable child has been described.

## ABDOMINAL PREGNANCY

Some authorities doubt whether a *primary* abdominal pregnancy, that is, one in which a fertilised ovum implants itself initially on some abdominal organ, ever occurs. Well-documented cases, in which both tubes and ovaries were normal and separate from the pregnancy sac, are reported. However, most cases of abdominal pregnancy are *secondary* in that the pregnancy is first implanted in the tube, ovary or uterus. In the case of the last it escapes by way of rupture of a scar (Fig. 9.19). The criteria for diagnosis of primary abdominal pregnancy are: normal tubes and ovaries with no evidence of recent or past pregnancy; no evidence of utero-placental fistula; pregnancy related to the peritoneal surface and early enough to eliminate the possibility of secondary implantation.

## Pathology

The usual sequence of events is for the foetus and chorion to commence their development in the tube. After a few



**Fig. 9.19** Secondary abdominal pregnancy, the empty uterine cavity being demonstrated by hystero-graphy

weeks, the foetus is extruded through the abdominal ostium or through a break in the wall of the tube, but does not die because its chorionic attachment and amniotic sac remain intact. When the amnion is intact the amount of liquor amnii is always small, probably because the normal contribution from the decidua, via the membranes, is missing. The chorion grows through the rent and forms attachments to the pelvic peritoneum, broad ligament, uterus, omentum and intestine. These structures react by developing large blood vessels to serve the placenta, and their anatomy becomes grossly disturbed. The foetus develops in the peritoneal cavity, its amniotic sac becoming supported by an outer coat of organising lymph and blood exudate.

The placental attachment is so insecure and the local decidual reaction so weak that retroplacental and intra-abdominal haemorrhage is likely at any time. Nevertheless, some abdominal pregnancies proceed to term when spurious labour ensues. The uterus then contracts painfully and rhythmically and there is some dilatation of the cervix with a discharge of blood and decidua. The foetus dies but remains in the abdominal cavity where it undergoes maceration or other change as described on page 148 (Fig. 9.20).

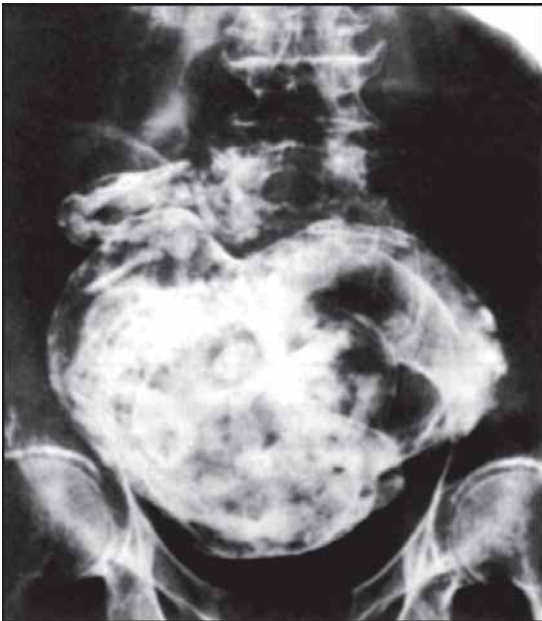


Fig. 9.20: A lithopaedion in the abdomen of a woman aged 84 years. It was left untreated. (Mr C.H.Walsh's case)

### Clinical Features

If closely questioned, the patient usually gives a history suggestive of tubal implantation in the early weeks. The pregnancy then proceeds apparently normally except it is unusually uncomfortable; intestinal distension, periodic abdominal pain, and occasional slight uterine bleeding are common. The foetus usually takes up an abnormal attitude and position. Contrary to what might be expected the foetus is *not* specially easy to feel: the whole tumour is asymmetrical but difficult to define and the abdomen is tender in one or other area. The uterus *may* be felt as a tumour separate from the pregnancy sac and be mistaken for a leiomyoma or cyst, the distinguishing feature being that it contracts from time to time. The *pregnancy mass, on the other hand, does not contract*. On vaginal examination the cervix is nearly always found displaced, often upwards and forwards with foetal parts lying below and behind it.

### Diagnosis

This can be surprisingly difficult and many cases were missed until late in pregnancy before the more routine use of ultrasound. Sometimes the diagnosis is suspected only when repeated attempts at induction of abortion or labour are unsuccessful. Pregnancy in one horn of a uterus didelphys can be difficult to exclude. Radiological examination is particularly helpful for it not only reveals an unusual foetal attitude and position but gas shadows of *coils of intestine superimposed on the foetal skeleton*. Lateral radiographs of the standing woman may also show some part of the foetal skeleton on a plane posterior to the anterior border of the maternal spine. Hysterography confirms the diagnosis but cannot be employed so long as there is any chance of the pregnancy being within the uterus (Fig. 9.19). Experience of rare conditions takes time to accumulate but the ultrasonic findings are in essence similar to those described above and the empty uterus more easily identified.

### Treatment

Laparotomy should generally be undertaken as soon as the diagnosis of abdominal pregnancy is made. The operation is dangerous because the anatomical relations are likely to be disturbed, and great skill and gentleness are necessary if serious haemorrhage is to be avoided. The difficulty is to control the sinuses of the placental



site when it involves the intestines and the peritoneum. If the site be such that the maternal vessels leading to it are easily ligated, the foetus and placenta are removed. If the placenta is implanted dangerously, it is often better to remove the foetus without disturbing its sac. The umbilical cord is cut short and the placenta and membranes are left to be absorbed during the next 1 or 2 years. Only rarely do they have to be removed later, and then usually because of abscess formation. In such cases the hCG and plasma progesterone levels fall only gradually during the course of 8-12 weeks. Methotrexate has been used to manage the residual placenta but can accelerate tissue necrosis and cause severe infection.

There may be circumstances, when it offers the patient her only chance of a live child for example, in which it is justifiable to delay operating until the foetus is viable. This course is only to be followed after

considering the serious maternal risk involved, and in the knowledge that the child is likely to be mis-shapen, albeit not permanently, and that the neonatal death rate is 50 per cent.

If the foetus dies in the abdomen it is sometimes wiser to defer operation to allow the placental sinuses to become thrombosed. In such cases the maternal coagulation profile needs to be monitored.

### **INTRALIGAMENTARY PREGNANCY**

Intraligamentary pregnancy is similar to secondary abdominal pregnancy in that it arises secondarily to tubal implantation, the tube rupturing extra-peritoneally and discharging the foetus between the layers of the broad ligament. If the chorionic attachment remains undisturbed and the foetus lives, the further progress, clinical features, complications and treatment are similar to those of abdominal pregnancy.

# CHAPTER 10

## Gestational Trophoblastic Disease

Types of Tumours	160
Hydatidiform Mole	162
Persistent Gestational Trophoblastic Tumour	167

### Epidemiology

The incidence of Gestational trophoblastic disease (GTD) vary dramatically in different regions of the world. The variation in the incidence rates of molar pregnancy may in part result from differences between reporting population-based versus hospital-based data. Reviewing all products of conception from first- and second-trimester abortions a study based on a complete pathologic review, the incidence of complete and partial mole was found to be 1 per 1,945 and 1 per 695 pregnancies, respectively. The high incidence of molar pregnancy in some populations has been attributed to nutritional and socioeconomic factors. Areas with a high incidence of molar pregnancy also have a high frequency of vitamin A deficiency. Dietary factors, therefore, may partly explain regional variations in the incidence of complete mole. Maternal age older than 35 years has consistently been shown to be a risk factor for complete mole. Ova from older women may be more susceptible to abnormal fertilisation. Limited information is available concerning risk factors for partial molar pregnancy. However, the epidemiologic characteristics of complete and partial mole may differ. There is no association between maternal age and the risk for partial mole. The risk for partial mole has been reported to be associated with the use of oral contraceptives and a history of irregular menstruation, but not with dietary factors.

### TYPES OF TUMOURS

This chapter is concerned with tumours which can arise in the epithelium of the trophoblast. This does not include the *primary choriocarcinoma* sometimes found in teratomas, but the trophoblast resulting from fertilisation of an ovum. Trophoblastic tumours are all malignant or potentially malignant, and histologically show various grades of differentiation, from a recognisable chorionic villus structure to highly virulent anaplastic masses of cells. Gestational trophoblastic disease (GTD) comprises a spectrum of interrelated tumours, including complete and partial hydatidiform mole, placental site trophoblastic tumour and choriocarcinoma. While these have varying behaviour regarding local invasion and metastasis, even those with widespread dissemination can be cured completely. Although persistent

gestational trophoblastic tumours (GTTs) most commonly follow a molar pregnancy, they may ensue after any gestational event, including therapeutic or spontaneous abortion, ectopic pregnancy, or term pregnancy.

Since the introduction of effective chemotherapy, one need not have representative tissues from the uterus or metastases in order to start treatment. An elevated titre of human chorionic gonadotrophin (hCG) in the appropriate clinical situation is all that is required to initiate treatment. Although the prognosis may be affected to a certain degree by the type of tumour, histologically it is impossible to reliably assess the malignant potential of a given tumour.

In practice, the biological activity and clinical behaviour of the tumour are better indices of prognosis.

### Aetiology

Normal trophoblast behaves in many ways like a malignant growth. It locally invades maternal tissues and fragments of it enter the bloodstream to lodge in the lungs. These properties, however, are normally controlled by some maternal factor (immunological) or non-factor, so that invasion of the uterine wall is limited and any extrauterine deposits are destroyed. In this respect it has to be recognised that trophoblast is made up of tissues which are only 50 per cent maternal. The paternal contribution is presumably foreign to the host so there must normally also be some mechanism whereby its rejection is prevented. The occurrence of a trophoblastic tumour can be regarded as the result of a breakdown in what must be a complicated and delicate host-invader balance. It has been suggested that trophoblastic tumours, or at least the choriocarcinoma, are more likely to arise as a consequence of the first pregnancy by a particular man, and that when they occur in a multiparous woman the pregnancy often has a different paternity. Behind this is the idea that every first conception tests a woman's capacity to resist and control the trophoblast produced by a particular mating. Having succeeded, she is more or less immune to choriocarcinoma in the future, unless she takes a new mate to whose offspring she has not acquired a resistance. Although there is documentary evidence pertaining to cases arising in North America, the United Kingdom and Taiwan to substantiate this thesis, it is not upheld by most observations made on Asiatic women in whom choriocarcinoma is much more common in later than in

first pregnancies. Other evidence supporting the concept of a paternal aetiological factor is the fact that it is not uncommon for more than one wife of the same man to die from choriocarcinoma. Considering the rarity of the disease this must be more than a chance occurrence. Blood groups also play some part. The group A woman mated with a group A man is at least risk; and the woman whose blood group is AB is at greatest risk. There are also reports of matching leucocyte HLA types between the woman and her partner.

The idea of an underlying breakdown in normal host resistance could explain why choriocarcinoma often appears months and even years after the causal pregnancy. This suggests that the woman is able to resist fragments of trophoblast and to keep them dormant until a time comes when her powers of resistance fail for some reason. In those cases in which spontaneous regression of metastatic deposits occurs, and there are many authentic reports of this, it can also be supposed that the woman has in some way recovered from a temporary failure in normal host response.

Trophoblastic tumours have a striking geographical distribution. In Europe and North America they are rare; they are more common in the Middle East, and occur most frequently in South-East Asia, Malaysia, Singapore, Hong Kong, Indonesia, the Philippines and China. The incidence is also relatively high in Central Africa. These observations at first suggest a racial or inherent aetiological factor, which is also in keeping with the concept of a variable host resistance. However, in Malaysia at least, the tumours occur with equal frequency in women of Indian, Chinese and Malay stock. The Europeans in that area remain relatively immune so it is suggested that trophoblastic diseases occur especially in 'rice eaters'. There is also clear evidence that, in those particular countries, trophoblastic tumours mainly affect those women who are of high parity, malnourished or debilitated by diseases such as tuberculosis. Dietary deficiency of carotene has also been associated with an increased incidence of complete molar pregnancy.

Thus the lack of ability to control trophoblastic activity has two possible bases: an inherent or immunological one; and one which results from malnutrition and debility.

Chromosomes of partial moles generally have a triploid karyotype (69 chromosomes); the extra haploid set of chromosomes usually is derived from the father.

## HYDATIDIFORM MOLE

### Incidence

In Europe and North America, trophoblastic disease complicates 1 in every 1000-2000 pregnancies. The incidence is as high as 1 in 200-300 live-births in South-East Asia. Women aged over 40 are particularly susceptible to complete mole and are responsible for at least one-third of all cases. There is also a suggestion that there is an increased risk in the 14-16-year-old primigravida. However, there is no association between maternal age and the risk for partial mole. A previous hydatidiform (vesicular) mole is a risk factor for recurrence of hydatidiform mole as well as for the development of choriocarcinoma.

Hydatidiform change can occur in one ovum of a twin pregnancy, the other developing normally; it can also complicate ectopic gestation. What follows mainly concerns the typical intrauterine molar pregnancy but applies generally to the condition in any site.

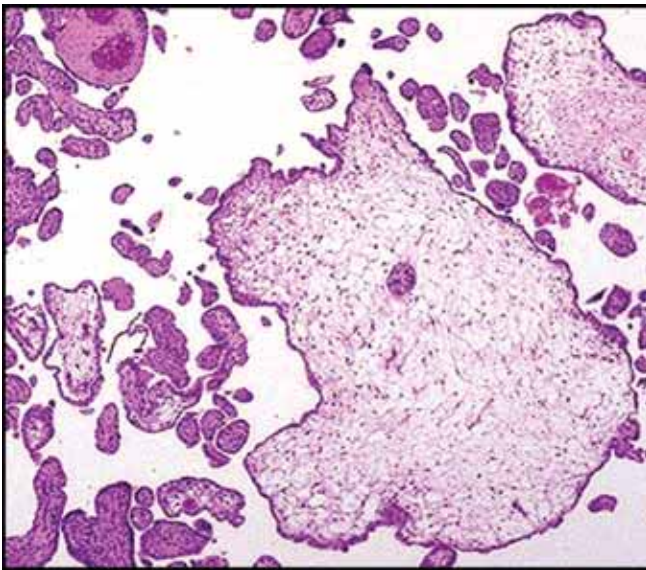
### Pathology

A hydatidiform mole is a *neoplasm of the trophoblast* which involves both epithelial layers, cytotrophoblast and syncytiotrophoblast, in different proportions in different cases. Although the histological picture varies, the typical

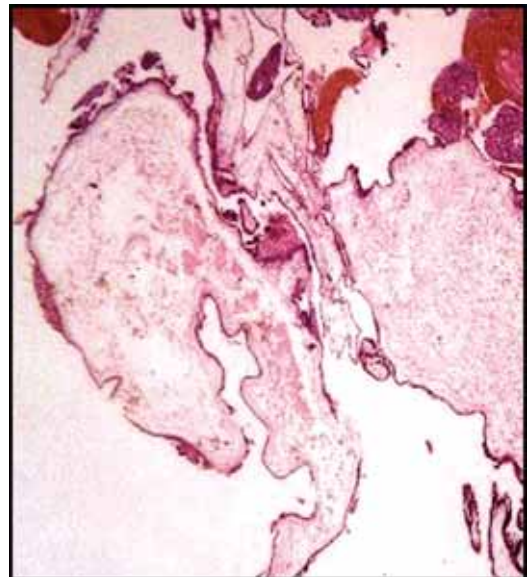
complete diffuse mole shows proliferation and pleomorphism of epithelial cells whose nuclei are hyperchromatic and actively mitotic (Fig. 10.1). The stroma of each villus is at first oedematous but soon the whole central core, including most of the vessels, is destroyed. The villus then swells to form a rounded cyst filled with watery fluid. The chorion thus becomes converted into a mass of grape-like structures each attached by a fine stalk (Fig. 10.2). The cysts vary in size from a pin head to a cherry. No foetal tissue can be identified.

The mechanism by which the cysts form is a subject for several theories: primary death of the foetus results in failure of the villus circulation and consequent oedema and liquefaction of the stroma; a primary error in the development of the vessels in the core causes the villus to become overloaded with fluid and foodstuffs, the latter then providing the epithelial cells with an excessive growth stimulus; or primary overactivity of the covering epithelium of the villus, possibly in response to anoxia, is manifested by active secretion of fluid into the core of the villus as well as by cellular hyperplasia. The last is the most likely explanation and in its support is the fact that the fluid is rich in hCG.

Although *partial* hydatidiform change in a placenta without death of the foetus does occur, it is rare (Figs



**Fig. 10.1:** Placenta, partial hydatidiform mole. Enlarged, oedematous, vesicular villi of normal size and appearance are present



**Fig. 10.2:** Placenta, hydatidiform mole. All the villi in this complete mole are enlarged and vesicular to a varying degree. The trophoblastic mantle shows mild to moderate circumferential hyperplasia. (Photomicrograph x 40)

10.3 and 10.4). Some cases so described are probably examples of twin pregnancy with only one conceptus affected. Ordinarily the foetus dies, probably as a result of failing chorionic function. The disease usually arises in the very early weeks of pregnancy so the foetus remains only as a rudimentary structure. Foetuses which survive generally exhibit the stigmata of triploidy like intrauterine growth restriction and congenital malformations, e.g. syndactyly, hydrocephalus, etc. Occasional normal births have, however, been reported.

Pathological features which characterise the partial mole as distinct from the complete mole are the presence of foetal or embryonic tissue, focal changes of hydatidiform swelling of chorionic villi and trophoblastic hyperplasia, marked scalloping of chorionic villi and prominent trophoblastic stromal inclusions.

In partial hydatidiform mole, persistent tumour develops in approximately 4 per cent of patients. The majority of these have a triploid karyotype. The disease is usually non-metastatic in nature.

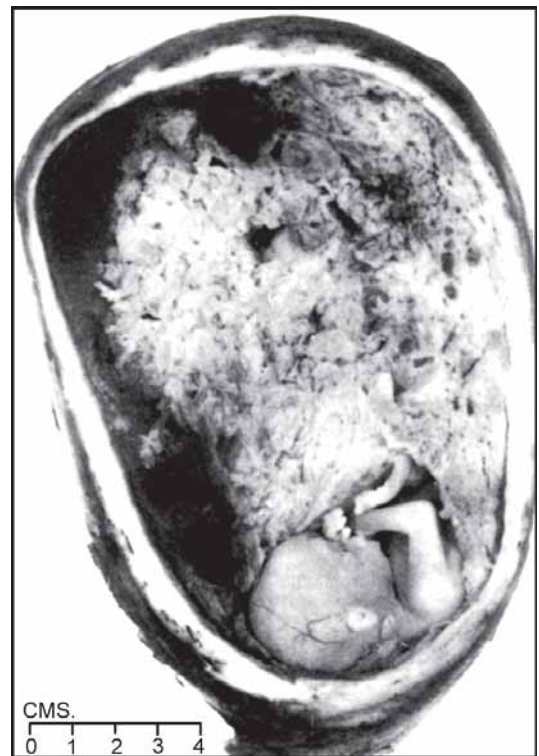
Analysis of the sex chromatin pattern of hydatidiform moles has revealed that the majority are female. This is due to the *complete* or *classical* mole possessing a dual set of paternal genes and none of maternal origin (due to the development of an ovum under the influence of the nucleus of a spermatozoon but with the usual nucleus of the ovum being absent or inactivated). Even



**Fig. 10.3:** A partial hydatidiform mole in the uterus of a multiparous woman aged 40 treated by hysterectomy

in the 10 per cent which have a 46,XY karyotype, the chromosomes appear to be of paternal origin. The *partial* mole, which has hydropic villi interspersed among normal villi and is associated with a foetus, has chromosomal abnormalities which are triploid in the majority of cases, the extra haploid set of chromosomes generally being derived from the father. It is postulated that there is no transition from partial to complete moles and malignant change is very rare in partial moles.

Despite foetal death the mole continues to grow, so the uterus enlarges and may be bigger than that housing a normal pregnancy of similar age. The overactivity of the chorion is also evidenced by its production of abnormally large amounts of human placental lactogen (hPL) and hCG. The latter acts on the patient's ovaries to produce excessive luteinisation which may take the form of *multiple theca lutein cysts*. Such tumours are bilateral and can be as large as oranges (Fig. 10.5). Although the cysts are typically lutein, some may be follicular; both types are entirely hormone-dependent and they disappear when the gonadotrophic stimulus is withdrawn.



**Fig. 10.4:** An unusual partial hydatidiform mole with a foetus present. In this case, as in the majority of those with a foetus present, there would characteristically be foetal triploidy



**Fig. 10.5:** Bilateral theca lutein cysts associated with fundal choriocarcinoma

The output of steroid hormones and their derivatives, by the mole or the lutein cysts or both, is variable.

Hydatidiform mole must always be regarded as a potentially malignant condition though the activity of the chorion is extremely variable. A mole may die *in utero* so that tests for gonadotrophin in the urine become negative and the clinical picture is that of missed abortion. Excluding this possibility, moles can be classified into groups, *the distinguishing features being their behaviour rather than histological appearance.*

Complete hydatidiform mole is the typical mole which, although tending to invade the myometrium more than does a normal placenta, generally has a benign behaviour. Fragments remaining in the uterine wall after its removal usually atrophy and only give rise to local uterine invasion in 15 per cent and metastases in 4 per cent of cases. The risk is highest if the serum hCG level at presentation is >100 000 mIU/ml, the uterus is excessively enlarged or the theca lutein cysts are >6 cm in diameter. In these women the chance of subsequent choriocarcinoma maybe 10 per cent. Older women are also at a higher risk of developing persistent tumour.

### Clinical Features

The symptoms and signs of complete hydatidiform mole are at first those of early pregnancy but, with the development of the mole, the general reactions are exaggerated. Excessive vomiting is common, the patient loses weight, and she feels and looks ill. Pre-eclampsia

develops in approximately one-third of the cases and earlier than usual. Its appearance is directly related to the weight of the mole, and this suggests that excessive trophoblastic activity is the primary cause of the pre-eclampsia. Strangely, eclamptic convulsions rarely supervene.

The symptom which most often calls attention to the abnormality is recurrent uterine bleeding and brown discharge. The initial diagnosis is therefore likely to be threatened abortion and, in approximately 50 per cent of cases, the mole is not suspected until it is expelled in part or whole, or the patient undergoes ultrasonography to check for foetal viability. Abortion almost always takes place sooner or later. Heavy and prolonged vaginal bleeding superimposed on pre-existing malnutrition leads to anaemia in half these women.

The possibility of hydatidiform mole should be considered whenever the symptoms of threatened abortion do not subside quickly or when they recur, and especially if the patient is reacting badly to the pregnancy. The physical signs are as follows:

- The uterus is too large for the period of amenorrhoea. This sign is present in only 50 per cent of cases; sometimes the uterus is smaller than normal, especially if the mole dies.
- The uterus is doughy in consistency and does not contract.
- Foetal parts are not felt.
- Foetal movement and heart sounds are absent.
- The passage of vesicles in the uterine discharge is conclusive evidence but rarely occurs until abortion is imminent.
- Bilateral ovarian enlargement is palpable in 25-50 per cent of cases.

A rare but fascinating development is thyro-toxicosis. Although several investigators speculated that a unique thyroid stimulating hormone (TSH) is synthesised by trophoblastic tissue, there is evidence that hCG itself may cause hyperthyroidism. Human chorionic gonadotrophin has an alpha subunit identical to that of TSH and therefore has an inherent capacity to stimulate the thyroid. The thyrotoxicosis disappears dramatically when the mole is removed, but may be severe enough to require treatment with  $\beta$ -adrenergic blockers before operation or the patient can have a thyroid storm.

In patients with partial hydatidiform mole, the clinical picture is not so dramatic. Of the clinical features described above, only vaginal bleeding is usually seen,

the remaining features being seen in less than 4 per cent of cases. The general presentation is that of incomplete or missed abortion. Now-a-days, many more cases are being diagnosed by ultrasound.

### Diagnosis

When the clinical features are suggestive, the following tests can be applied.

#### Ultrasound

Ultrasonography is the diagnostic method of choice because of its reliability, sensitivity and safety. The diffuse hydropic swelling of the chorionic villi produces a characteristic 'snow-storm' appearance throughout the uterine cavity (Fig. 10.6). No gestation sac or foetus can be identified. A similar picture can, however, sometimes be seen in cases of degenerated leiomyomas or adenomyomatous polyp.

In the case of a partial mole, focal cystic spaces are seen in the placental tissues and the transverse diameter of the gestation sac is increased.

#### Human Chorionic Gonadotrophin

The serum level of  $\beta$ -hCG is markedly elevated. The condition most likely to be confused with hydatidiform mole is multiple pregnancy. This, in the early months, is not infrequently manifested by threatened abortion, an unusually large uterus, vomiting and elevated  $\beta$ -hCG levels. Consequently, hCG estimations cannot be depended upon alone for absolute diagnosis of hydatidiform mole, although they usually add strong supporting evidence. Since accurate dating of the pregnancy is necessary for assessment of the level of hCG, ultrasonic examination is essential, and will also prove the diagnosis. The two modalities are thus complementary to each other. Serum  $\beta$ -hCG level is important in the follow-up.

### Dangers

These are severe haemorrhages, with or without an associated coagulation disorder, at some stage of the expulsion of the mole; infection; perforation or rupture of the uterine wall by the invading chorion or by attempts to remove it; and simultaneous or subsequent development of choriocarcinoma. The risk of malignant change averages 5 per cent. If, however, there is proper supervision of all affected women, with the administration of

cytotoxic drugs when indicated (*see below*), the risk is small.

### Treatment

*If the mole is spontaneously expelled* from the uterus, the immediate treatment is the same as for inevitable abortion.

*If none of the mole is expelled* when the diagnosis is made, the uterus must be emptied as soon as possible. Suction curettage is done with a wide-bore cannula, even if the uterus is 20 weeks or more. Blood should be cross-matched and kept available if necessary and an intravenous lifeline should be in place. Accumulated old blood and fresh blood in the lower part of the uterus may gush out at first, but continued suction will remove the mole and control the bleeding. After the uterus is evacuated, a gentle sharp curettage of the uterus should be carried out. It is now recommended that an oxytocin drip should be started only after evacuation is complete to decrease the risk of trophoblastic embolisation. Rh-negative women should receive Rh immune globulin as trophoblast cells express the RhD factor. *A check ultrasound is done after one week to see the completeness of the evacuation.*

Suction curettage is the preferred method of evacuation, regardless of uterine size, for patients who desire to preserve fertility. It involves the following steps:

1. Oxytocin infusion—This procedure is required to keep the uterus contracted so that the bleeding is less during the procedure of evacuation.
2. Cervical dilation—Usually the cervical dilatation is not required as the cervix is very soft and easily permits the use of the suction canulae.
3. Suction curettage—Passage of the uterine sound is avoided as this may cause perforation of the uterus sometimes. Within a few minutes of commencing suction curettage, the uterus may decrease dramatically in size, and the bleeding is generally well controlled. The use of a 12-mm cannula is strongly advised to facilitate evacuation. The tip of the suction canula is inserted just beyond the internal os. Deep insertion of the suction canula near the fundus may cause uterine perforation as the uterus will be very soft in this condition. If the uterus is larger than 14 weeks of gestation, one hand should be placed on top of the fundus, and the uterus should be massaged to stimulate uterine contraction and reduce the risk of perforation.

Hysterectomy may be performed with the mole *in situ* for women aged 40 and over who have completed their families. However in spite of hysterectomy a careful follow up is required since choriocarcinoma can still develop. The ovaries can be preserved; large theca lutein cysts can be decompressed by aspiration. In any case, these disappear spontaneously once the chorionic activity is quelled.

Most medical oncologists believe in careful follow up and in the administration of cytotoxic drugs only as and when required. They point out, justifiably, that only 20 per cent of women who deliver a hydatidiform mole develop persistent tumour. There is some evidence that routine prophylactic chemotherapy can prevent the incidence and morbidity of locally invasive disease as well as metastases. A decision in any case may depend on facilities for follow up as well as on patient cooperation. There maybe a place for prophylactic chemotherapy in the management of high-risk complete molar pregnancy, especially when hormonal follow up is unavailable.

### Further Management

The material removed from the uterus is always examined histologically but the microscopic appearance by itself is not reliable to assess the prognosis. Knowledge of the blood groups of the patient and of her husband can indicate whether she is in the category at special risk. In any case, and even if the mole has been removed by hysterectomy, regular observation of the patient is essential to detect the first sign of remaining or reawakening chorionic activity. After six ovulatory cycles which is made out by six regular cycles, the next pregnancy is allowed. However if the woman goes to persistent trophoblastic tumour the next pregnancy should be avoided for two years. Pre-eclampsia develops almost exclusively in patients with excessive uterine size and markedly elevated hCG levels. Hydatidiform mole should be considered whenever pre-eclampsia develops early in pregnancy. Hyperemesis requiring antiemetic or intravenous replacement therapy may be seen particularly in those with excessive uterine size and markedly elevated hCG levels. Severe electrolyte disturbances may develop and require treatment with parenteral fluids. Currently, less than 10 per cent of patients have hyperemesis. Irregular uterine bleeding and amenorrhoea can both signify the development of

persistent disease. The persistence or development of cystic ovaries can also suggest continued chorionic activity. The most reliable method of follow-up is by serum  $\beta$ -hCG assay. Prominent theca lutein ovarian cysts (6 cm in diameter) develop in about one-half of patients with a complete mole. Theca lutein ovarian cysts result from high serum hCG levels, which cause ovarian hyperstimulation. Ultrasonography can accurately document their presence and size. After molar evacuation, theca lutein cysts normally regress spontaneously within 2 to 4 months.

Prominent theca lutein cysts may cause symptoms of marked pelvic pressure, and they may be decompressed by laparoscopic or ultrasonographically directed aspiration. If acute pelvic pain develops, laparoscopy should be performed to assess possible cystic torsion or rupture.

### Gonadotrophin Assays

Serum  $\beta$ -hCG levels are assayed every week after molar evacuation till 3 consecutive levels are found to be normal. Thereafter the assays are done at monthly intervals until they are normal for 6 consecutive months.

Serum hCG levels remain high for a longer time after evacuation of a mole than after a normal pregnancy. The average time to achieve the first normal hCG level after evacuation is about 9 weeks. If, after a phase of normal hCG titres, the patient is found to have high levels, the *occurrence of a new conception* must be excluded before it is assumed that she has developed choriocarcinoma. For this, and other reasons, it is important at the outset to warn the woman against conceiving again within 12 months of having a hydatidiform mole. In this respect, however, care is necessary over the method of contraception advised. An intrauterine contraceptive device (IUCD) is inadvisable because it may cause uterine bleeding to raise the fear of choriocarcinoma. Insertion of an IUCD before normalisation of hCG levels also carries the risk of perforation. If the patient does not desire surgical sterilisation, the choice is to use either oral contraceptives or barrier methods. Previously the combined oestrogen-progestogen pills were avoided as it was feared that they would increase the risk of postmolar trophoblastic diseases. However, these fears have not been substantiated and the combined pills are actually preferred because they provide reliable contraception. Progestogen-only pills, however, are



liable to produce irregular bleeding and should not be used.

In subsequent pregnancies, because of the slight chance of choriocarcinoma developing, it is always advisable to confirm normal development by an ultrasound in the first trimester. The placenta or products of conception should be sent for histological review on delivery and the hCG level checked 6 weeks after pregnancy to rule out trophoblastic neoplasia.

### Contraception

Patients are encouraged to use effective contraception during the entire interval of hCG follow-up. Because of the potential risk of uterine perforation, intrauterine devices should not be inserted until the patient achieves a normal hCG level. If the patient does not desire surgical sterilisation, the choice is to use either oral contraceptives or barrier methods. It was reported earlier that there was increased incidence of persistent trophoblastic tumours when oral contraceptives were used for contraception following evacuation of Hydatidiform mole. But it appears that oral contraceptives may be used safely after molar evacuation during the entire interval of hormonal follow-up.

#### *Indications for Chemotherapy after Hydatidiform Mole*

The risk following the evacuation of a hydatidiform mole, is principally that of developing persistent trophoblastic tumour. The principles of all follow-up programmes must be to ensure that all patients who require chemotherapy should receive it at the time it is effective; and it is not given to those patients who do not need it. If this cannot be done, prophylactic chemotherapy is justified. Some of the factors which influence attendants to use chemotherapy have already been mentioned, namely, the age, parity, and mode of evacuation, as well as the geographical variations.

*Criteria for treatment are as follows:* High levels of hCG more than 4 weeks postevacuation; progressively increasing levels of hCG at any time postevacuation; any detectable level of hCG not showing a tendency to disappear 4-6 months postpartum; and evidence of metastases with any level of hCG.

After one molar pregnancy, the risk of having molar disease in a future gestation is about 1 per cent.

### Persistent Trophoblastic Tumour

The serum hCG level is measured weekly after each course of chemotherapy, and the hCG regression curve serves as the primary basis for determining the need for additional treatment. If the patient's response to the first treatment was adequate and a second course of MTX-FA is required the dosage of MTX is unaltered. An adequate response is defined as a fall in the hCG level by 1 log after a course of chemotherapy. If the response to two consecutive courses of MTX-FA is inadequate, the patient is considered to be resistant to MTX, and Act-D is promptly substituted. If the hCG levels do not decline by 1 log after treatment with Act-D, the patient also is considered resistant to Act-D as a single agent. She must then be treated intensively with combination chemotherapy to achieve remission. The EMA-CO (Etoposide, Methotrexate, Actinomycin, Cyclophosphamide, Oncovin) regimen is generally well tolerated, and treatment seldom has to be suspended because of toxicity. The EMA-CO regimen is the preferred primary treatment in patients with metastasis and a high-risk prognostic score.

Therefore, for any subsequent pregnancy, it seems prudent to undertake the following approach:

1. Perform pelvic ultrasonographic examination during the first trimester to confirm normal gestational development.
2. Obtain a thorough histologic review of the placenta or products of conception.
3. Obtain an hCG measurement 6 weeks after completion of the pregnancy to exclude occult trophoblastic neoplasia.

Pregnancies after persistent GTT patients with GTT who are treated successfully with chemotherapy can expect normal reproduction in the future.

### PERSISTENT GESTATIONAL TROPHOBLASTIC TUMOUR

This is generally classified as non-metastatic and metastatic disease.

#### Non-metastatic Disease

Non-metastatic locally invasive gestational trophoblastic tumour (GTT) develops in about 15 per cent of patients after molar evacuation, though it may

infrequently develop after other gestations. The patients present with irregular vaginal bleeding. On examination, the uterus may show subinvolution and may be asymmetrical in its contour. Theca lutein cysts may be present. Serum  $\beta$ -hCG levels are persistently elevated. Perforation of the tumour through the myometrium may cause intraperitoneal haemorrhage. If a vessel is eroded, massive vaginal bleeding may occur. The necrotic tumour tissue is a focus for infection.

#### *Placental Site Trophoblastic Tumour*

This is an uncommon, monomorphic trophoblastic tumour comprised principally of cytotrophoblast. The lesion may be microscopic in size or form a soft, brown, partly haemorrhagic mass which protrudes into the uterine cavity and infiltrates the myometrium. The placental site trophoblastic tumour shows a range of behaviour from benign, with a capacity for spontaneous regression, to a highly malignant form which proves resistant to cytotoxic chemotherapy. It differs from choriocarcinoma in that it produces relatively little hCG and hPL in relation to the size of the tumour. When diagnosed it is essential to follow-up patients with serum  $\beta$ -hCG levels.

Typically it occurs in the reproductive years and the patient presents with amenorrhoea and uterine enlargement. Most of the sensitive radioimmunoassays for pregnancy will be positive and a clinical diagnosis of missed abortion is likely to be made. Curettage can lead to uterine perforation because the tumour penetrates deeply into the myometrium. These tumours are best treated by hysterectomy if still localised to the uterus. Conservative surgery with excision of the tumour has been described in sporadic cases where preservation of fertility is desired.

### **Metastatic Disease**

#### *Incidence*

Choriocarcinoma is rare; it has a geographical distribution similar to that of hydatidiform mole, and occurs in the same type of women. In Britain and North America, choriocarcinoma arises only once for every 50,000-70,000 pregnancies. In the Far East and in Central Africa, the incidence is one case for every 5000-6000 pregnancies, those women affected being mostly relatively old, of high parity and in poor physical

condition. The Middle East holds an intermediate position.

The growth may commence, in its full malignant form, during pregnancy but more commonly arises afterwards from remaining islets of trophoblastic tissue. Nevertheless, small foci and microscopic areas of choriocarcinoma in otherwise normal term placenta are described. These give no clinical evidence of their presence and it seems possible that many small growths of this type are missed. Some may be delivered with the placenta and give no more trouble; others may be the origin of the choriocarcinoma which follows normal pregnancy.

When choriocarcinoma develops during normal pregnancy, metastases may rarely be found in the baby. These are mostly in the liver, indicating a bloodstream spread. In fact, choriocarcinoma accounts for about half the cases of metastatic disease in the foetus.

The interval between pregnancy, molar or other-wise, and the development of overt choriocarcinoma may be as long as 5 years or more, although it is usually less than 2 years. Extraordinary cases have been reported. In one, choriocarcinoma appeared 12 years after hysterectomy for a mole. In another, 'ectopic choriocarcinoma' developed in the lungs 20 years after the last pregnancy and 8 years after hysterectomy.

In 50 per cent of cases the condition is preceded by hydatidiform mole. In 25 per cent it follows abortion or ectopic pregnancy, and in the remaining 25 per cent, delivery of a normal foetus. A normal pregnancy intervening between a mole and the development of choriocarcinoma is recorded.

#### *Pathology*

The primary growth, which is a tumour of embryonic chorion, is usually in the uterine wall, but may be in the cervix or vagina, or in the tube or broad ligament following ectopic pregnancy.

The tumour is soft, necrotic and haemorrhagic so it appears plum-coloured to the naked eye (Fig. 10.6). Its invasive character is usually obvious and quite often there are multiple and apparently entirely separate primary nodules in the cavity and wall of the uterus. Although the degree of malignancy varies, it is usually high and the growth spreads early by local extension into the broad ligaments and paracolpos, and by the bloodstream to the lungs, (80%), vagina (30%), pelvis (20%), brain (10%) and liver (10%).

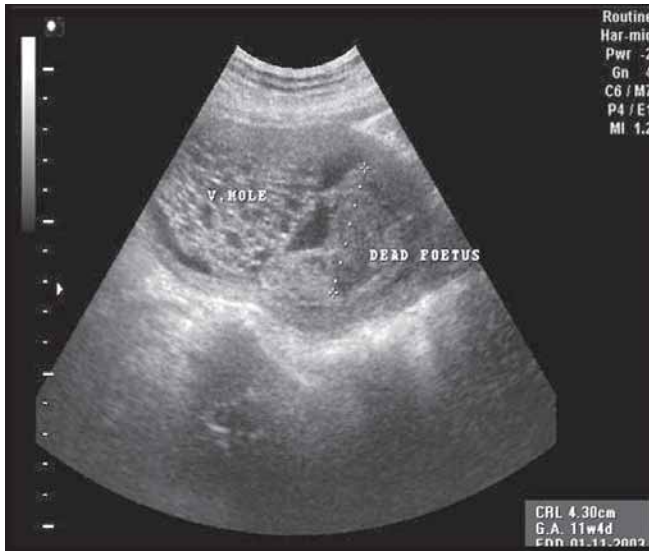


Fig. 10.6: USG showing mole and foetus

On section, the tumour shows cyto- and syncytiotrophoblastic cells in varying numbers, actively proliferating and assuming bizarre forms; also mononucleated and multinucleated giant cells (Figs 10.7 and 10.8). When syncytial tissue predominates, the growth is sometimes called a *syncytial knot* – a distinction of little practical importance. Chorionic villi are characteristically absent.

A choriocarcinoma is functional and usually secretes hCG in large quantities. This causes luteinisation (with or without cyst formation) of the patient’s ovaries (Fig.

10.5). Occasionally the hCG level is low, possibly because the tumour is encapsulated, possibly because it is mainly composed of non-secretory elements. There may be mole and foetus co-existing (Fig. 10.6).

Choriocarcinomas also secrete hPL but the amount is variable; it has been suggested that it varies inversely with the degree of malignancy.

### Clinical Features

The leading symptom is irregular uterine haemorrhage, coming on sooner or later after the expulsion of a mole or a normal pregnancy. The haemorrhage is characteristically intermittent but *alarmingly heavy* while it lasts. Such bleeding is arterial and can arise either from a nodule in the vagina or from one in the uterus. For the former, the treatment has been by suture; for the latter, an emergency hysterectomy may be necessary to control bleeding into the vagina or into the peritoneal cavity. As the condition advances, an offensive vaginal discharge develops and cachexia with pyrexia supervenes.

Often, the disease presents by way of its metastases. Thus, the occurrence of a haemothorax, a complaint of dyspnoea or haemoptysis, or the appearance of neurological signs and symptoms such as headaches, visual disturbances or focal neurological deficits can be the first evidence of choriocarcinoma. Chest radiography, revealing ‘cannon balls’ or a ‘snow storm’ appearance in the lungs may give the lead, as may a finding of acute pulmonary hypertension or pleural effusion. Solitary lesions appearing in the lungs or brain many years after

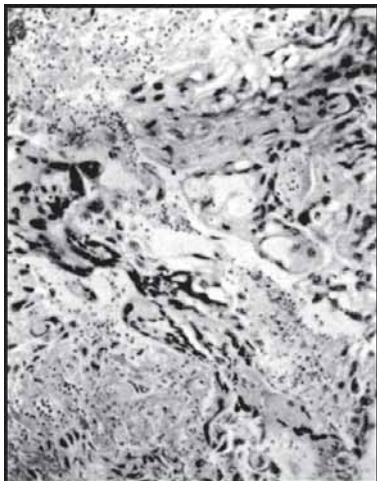


Fig. 10.7: Choriocarcinoma. The actively proliferating pleomorphic cells are derived from both layers of the trophoblast



Fig. 10.8: A higher-power view of choriocarcinoma, showing mainly syncytial cells

the causal pregnancy are often misdiagnosed. Hepatic metastases may stretch the hepatic capsule and present as epigastric or right upper quadrant pain. Such patients may also present as an acute emergency with massive intraperitoneal bleeding following hepatic rupture.

On pelvic examination, vaginal metastases may be seen; these are characteristically suburethral or in the fornices and bleed briskly if biopsied. The uterus often feels enlarged and cystic ovaries are sometimes palpable.

### Staging

Gestational trophoblastic tumour can be staged according to the FIGO system (Table 10.1).

### Diagnosis

The diagnosis is usually made or confirmed by the finding of high levels of serum  $\beta$ -hCG. Biopsy is contraindicated to prove any metastasis as it would lead to profuse bleeding. It should be noted, however, that *the growth does not always abut on to the uterine cavity so that curettage usually gives negative findings*. Another fact to be remembered is that in one-third of the cases of metastatic choriocarcinoma there is no evidence of disease in the uterus. **Curettage of uterus also is not needed as tissue diagnosis is not important. In fact curettage also may cause torrential bleed.**

A high index of suspicion is required for the diagnosis of metastatic disease. This differential diagnosis must be kept in mind when any woman who has ever been pregnant presents with pulmonary, neurological or hepatic symptoms as described above. The work-up includes a chest X-ray, a CT scan of the chest in some cases, an ultrasonogram or CT scan of the abdomen and pelvis, CT scan of the head and CSF hCG if required. CT

scan of the chest can show micrometastases or lesions located behind the heart shadow in patients with a normal chest X-ray. If there are pulmonary metastases, brain metastases must be ruled out, but in the absence of pulmonary metastases, brain metastases never occur. Pelvic ultrasonography may help to identify patients with large tumour bulk in and around the uterus and determine whether hysterectomy is indicated. Baseline complete blood count, hepatic, thyroid and renal function tests are part of the pretreatment investigation.

### Treatment

#### Chemotherapy

Chemotherapy is indicated in all cases of choriocarcinoma, alone or in conjunction with surgery. It is essential that all those treating these cases have available an accurate, reliable and sensitive method of determining hCG for the diagnosis, monitoring of therapy, and follow-up. They must be familiar with all the possible drugs, their mode of delivery and particularly their toxicity and how to control it. These are vital for optimal results and hence the advantage of referral of patients to special centres if possible and practical.

Several factors affect the prognosis and response to therapy apart from age, parity and blood groups (Table 10.2). The number and size of metastases will obviously influence the response, but the site is also important. Tumours involving the brain, liver and gastrointestinal tract have a poor response. The duration of the disease from the pregnancy, or the onset of symptoms associated with a pregnancy also influence the outcome. The critical time interval appears to be 4 months, since after that period of time the patient is less likely to respond to chemotherapy. The level of hCG prior to starting treatment is of major importance in predicting the response to therapy. Patients with serum hCG levels above 100,000 IU/litre have a poor response. If the diagnosis is made early, and with limited disease, even if metastases are present, patients have a good prognosis; but those patients who are treated late, have extensive disease and a high hCG output have a bad prognosis. It has also been noted that patients with metastatic disease following a term pregnancy fare less well than those following abortion or hydatidiform mole. Finally, those patients who are referred for treatment following previous chemotherapy or inadequate chemotherapy, as might be expected, fare badly.

**Table 10.1: Staging of gestational trophoblastic disease**

Stage I	Disease confined to uterus
Stage II	Gestational trophoblastic disease (GTD) extending outside uterus but limited to genital structures (adnexa, vagina, broad ligament)
Stage III	GTD extending to lungs with or without known genital tract involvement
Stage IV	All other metastatic sites

All stages subdivided as (a) No risk factors; (b) One risk factor; (c) Two risk factors

Risk factors: 1. hCG >100 000 mIU/ml  
2. Duration of disease >6 months from termination of antecedent pregnancy.

Table 10.2: Scoring system based on prognostic factors

Prognostic factors	Score			
	0	1	2	4
Age (years)	<39	>39		
Antecedent pregnancy	Hydatidiform mole	Abortion	Term	
Interval*	<4	4-6	7-12	>12
hCG(IU/L)	<10 <sup>3</sup>	10M0 <sup>4</sup>	10M0 <sup>5</sup>	>10 <sup>5</sup>
ABO groups (female X male)	O X A	B		
	AX O	AB		
Largest tumour, including uterine tumour	3-5 cm	>5 cm		
Site of metastases		Spleen, kidney	Gastrointestinal tract, liver	Brain
Number of metastases identified		1-4	4-8	>8
Prior chemotherapy			single drug	2 or more

The total score for a patient is obtained by adding the individual scores for each prognostic factor.

Total score: <4 = low risk; 5-7 = middle risk; >8 = high risk.

\* Interval time (in months) between end of antecedent pregnancy and start of chemotherapy.

Prior to commencing treatment, patients are graded according to their risk factors so that the optimal course of chemotherapy can be given (Table 10.2). The grading is either low-risk (good prognosis), or high-risk (poor prognosis). In some centres, there is a third grade in between these called medium-risk. Since there are well-known side-effects of all the drugs used, a careful check is made before a course of treatment is commenced or continued.

The principal adverse effects are on the bone marrow, the liver and kidney, so regular checks are made on white cell count, platelets, liver function and blood urea. The systemic effects as far as the patient herself is concerned are stomatitis, skin rash, alopecia, gastrointestinal disturbances and conjunctivitis, which are treated symptomatically. They rarely influence the decision about continuing drug therapy. Any life-threatening toxicity must be treated vigorously.

In non-metastatic and in low-risk metastatic GTT, single-agent chemotherapy is recommended. The drug of choice for single-agent chemotherapy is methotrexate given intramuscularly, 50 mg (35 mg/m<sup>2</sup>) on alternate days for four doses, with 6 mg of folinic acid given in the days between the four doses. An alternative single-agent drug is actinomycin D, 10-13 ng/kg per day, intravenously, for 5 days. The serum hCG is measured weekly after each course and if the level is found to be progressively declining, no further chemotherapy is given.

If the titre rises or plateaus at an elevated level after two courses, or if the hCG level does not undergo one log fall within 18 days after completing the first course, a second course is given in the same dosage and monitored similarly, until there is a negative  $\beta$ -hCG subunit assay. Once this level is reached, treatment is stopped or one further course given. This regimen is used for low-risk (good prognosis) cases which constitute the majority of the cases at risk on the two-grade system.

Patients with medium- and high-risk factors or those who have failed to respond to single-agent chemotherapy are given combination chemotherapy. The same criteria as mentioned above are used for changing a particular combination of drugs. Several regimens have been tried. Triple therapy with methotrexate, actinomycin D and cyclophosphamide (MAC) may be useful in cases with failed single-agent therapy but has remission rates of only 50 per cent in patients with metastases and a high-risk prognostic score.

The EMA-CO regime (etoposide, methotrexate, actinomycin D, cyclophosphamide and vincristine) is used in patients with metastatic GTT and a high-risk score. When a patient fails to respond to multi-agent therapy, her chances of cure are poor. Intra-theal methotrexate is administered for the treatment of CNS metastases.

A diagnosis of remission is not made until three consecutive weekly negative  $\beta$ -hCG subunit assays are obtained. After remission, two additional courses of

chemotherapy are given to reduce the risk of relapse. Follow-up is usually carried out with monthly hCG estimations for 2 years for stage I through III and for 2 years for stage IV disease. In general, less than 1 per cent of those who have been in remission for a year ever require further treatment. Cure is usually said to have occurred after a period of 5 years in remission. After two years in remission, patients who had retained their reproductive capacity may embark on another pregnancy if they wish.

### Surgery

If investigations failed to reveal evidence of extension of the growth outside the uterus, it was once the practice to proceed with immediate total hysterectomy. It still has a place in selected Stage I cases in whom future fertility is not desired or those who are resistant to chemotherapy. It is also indicated in patients with placental site trophoblastic tumour which is usually resistant to chemotherapy. Combined with chemotherapy, some gynaecologists favour this operation even when secondary deposits are known to exist in Stage II and III. They do so on the grounds that it is best to remove as much growth, primary or secondary, as is possible to give 'host response' and cytotoxic drugs the optimum effectiveness. In some it may be required to control uterine bleeding. In all cases there should be joint consultation, with either the medical oncologist or a specialised centre, regarding the management of each case. The fact that a proportion of cases (10-40% reported) in which hysterectomy is carried out reveal no evidence of choriocarcinoma on histological examination suggests that investigations carried out before surgery should indicate that the uterus is involved.

Whenever hysterectomy is carried out, the ovaries should be conserved. It is illogical to do otherwise. If the growth is confined to the uterus there is no point in removing the adnexa; if it has already entered the bloodstream it is equally useless. Metastases to the ovary are also rare, and these are usually easily identified at operation. Rarely, a young woman who wishes to retain her fertility does not respond to either single-agent or combination chemotherapy. In such patients, local uterine resection has been attempted after defining the exact site of the resistant tumour by MRI or arteriography.

Under the heading of surgery it is necessary to mention the occasional need for the excision of isolated nodules in the vagina and lungs when these persist after chemotherapy. Vaginal metastases may bleed profusely and may require wide local excision or arteriographic embolisation of the hypogastric arteries. Thoracotomy for excision of resistant disease should be supplemented with postoperative chemotherapy. Similarly, hepatic resection or arterial embolisation for hepatic lesions and craniotomy for cerebral resection may be required for localised metastatic disease or for control of bleeding.

### Radiotherapy

Radiotherapy is not an appropriate mode of treatment for pelvic lesions as it will interfere with the delivery of optimal chemotherapy. Whole brain irradiation is sometimes used in conjunction with chemotherapy for localised cerebral metastases to reduce the risk of haemorrhage. Intensive combination chemotherapy supplemented with intrathecal methotrexate has shown similar results.

### Results

The advent of chemotherapy improved survival rates dramatically, although the results of this, like those of surgery, depend on how early the disease is recognised and treated. If the tumour is confined to the uterus (or pelvis) and there is no evidence of metastatic disease, it is claimed that the cure rate is 90-97 per cent. When the disease is metastatic, then the remission rate is still high if it is considered to be in the group of good prognosis as judged by the pretreatment assessment. Some workers have reported very similar results to low-risk patients without evidence of metastatic spread. For patients with metastatic disease and poor risk, the remission rate is 75-90 per cent.

The best results are obtained amongst those cases discovered as a result of routine serial assays of hCG in women who have had a hydatidiform mole; treatment can then often be started before the disease; is clinically evident.

There is a place for surgery in cases treated with chemotherapy and it is possible that it may give the best results.

Contraception is essential during treatment and the period of hCG follow-up and is recommended as described above for hydatidiform mole. There is no real evidence that successfully treated trophoblastic disease is associated with subfertility or foetal wastage. There does not appear to be any increase in abortions, congenital abnormalities, perinatal loss or neonatal morbidity. The explanation suggested is that the period of contraception allows all mature ova affected by chemotherapy to be eliminated, whilst the resting oocytes are not affected by the drugs.

The treatment of gestational trophoblastic tumours has been one of the chemotherapy success stories since

the first patient of metastatic choriocarcinoma was cured in 1956. Nevertheless, there still remains the problem of treating patients where it is impossible to arrange for the necessary detailed hCG follow-up facilities, which are vital, or those individuals who are unlikely to return for their follow-up visits. Under these circumstances prophylactic therapy has a place. Even where all facilities are available and the patient cooperates, there is the problem of those who do not respond to therapy. With improvements in chemotherapy these are now very few in number and even these will hopefully be resolved in the foreseeable future.

# CHAPTER 11

## Breast Function and its Disorders

Breast Development	174	Endocrine Disorders (Galactorrhoea and Breast Atrophy)	179
Developmental Anomalies of Breast	176	Screening for Breast Diseases	183
Changes in Pregnancy and Lactation	177	Benign Breast Diseases	186
Breast Feeding and Lactation	178	Carcinoma Breast	188
Suppression of Lactation	179		
Drugs and Lactation	179		

### BREAST DEVELOPMENT

The female breasts (mammary glands) develop rapidly between the age group 10-20 years. The adolescent breast development takes place according to sexual maturity rating and the breast bud development is the first sign of puberty in girls at around eight years of age.

Embryologically the breasts (mammary glands) develop on the mammary line/ridge which is a thickened ectoderm from axilla to inguinal region.

On this mammary line the ectoderm thickens as a mass of epidermal cells and projects into the dermis in the pectoral region and this forms the mammary glands on both sides. About 15 to 20 outgrowths arise from this thickened epidermal mass and grow into the dermis to get surrounded by fat, vascular and connective tissue. The distal part of these outgrowths forms secretory elements and proximal part cannulates to form lactiferous ducts. All the ducts open into a pit which becomes elevated to form nipple.

The breast lobes develop at puberty in response to endocrine stimulation (Figs 11.1 and 11.2).

#### Stages of Breast Development at Puberty

At birth the breast is a simple system of ducts without alveoli. By 9-10 years female breasts begin to enlarge, first the area around nipples enlarges.



**Fig. 11.1:** Areolar bud (Patient on oestrogen therapy)





Fig. 11.2: Chiari-Frommel syndrome

- The ducts and acini develop in the next 3-4 years.
- By menarche there is fat deposition and breasts become prominent and round.
- Further enlargement of breasts occurs till 18 years of age.
- Prepubertal development is mainly due to oestrogens from ovary and also due to growth hormone and adrenal corticoids.
- The hormones which are required by a non-lactating breast to grow are oestrogens, progesterone, growth hormone, insulin, cortisol, thyroxine and prolactin.
- The receptors in mammary glands (cytoplasm of mammary epithelium) depend on prolactin and these receptors respond to oestrogen. Adequate fat deposition is also needed for normal breast development and this adipose tissue provides a loose matrix for glandular and ductal expansion under hormonal stimulation.
- The morphological changes in breasts at puberty are described by Tanner in five stages (P<sub>1</sub> – P<sub>5</sub>) (Fig. 11.3).

**Tanner's Staging**




- P<sub>1</sub> Prepubertal (Breast bud only)
- P<sub>2</sub> Early development of subareolar bud, widening of areolae, small amount of labial or axillary hairs

- P<sub>3</sub> Increase in size of palpable breast tissue and areolae. Increased dark pubic hair on mons veneris and of axillary hair and characteristic body odour.
- P<sub>4</sub> Further increase in breast size and areola which protrudes above breast level. Adult sexual hair but limited to pubes. Acne and menarche may occur.
- P<sub>5</sub> Adult breast and areolae. Adult amount and distribution of pubic hair with extension to upper thigh. Menarche occurs.

**Endocrine Control of Female Breast**

The mature breasts undergo a cycle which corresponds to the ovarian cycle. Oestrogen will stimulate ductal elements whereas oestrogen and progesterone stimulate glandular elements and increase in water content of breast. In the luteal phase there is increased epithelial activity (slight secretion) in the ducts and acini; this regresses during menstruation. The breast as a whole increases in size during a week before menstruation and this is mainly due to congestion and oedema of the connective tissue between lobules. This is manifested as premenstrual heaviness and pain and tenderness in breasts (Table 11.1).

**Table 11.1: Endocrine control of female breast development and function from prepubertal stage to pregnancy**

Stage	Duct system	Major Hormones	Permissive Hormones
Prepubertal		None	Unknown
Adult		Oestrogen (Progesterone)	
Pregnancy		Progesterone Prolactin Human placental lactogen	Insulin Thyroxine Glucocorticoids Growth hormone

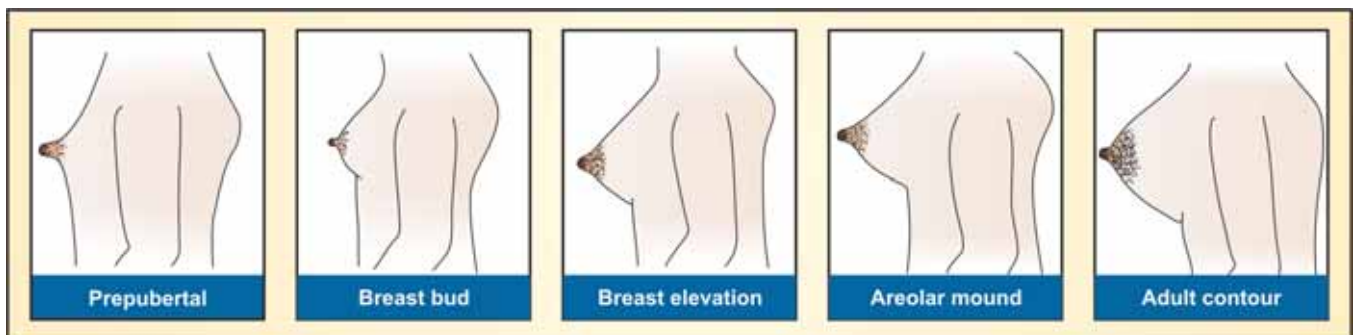


Fig. 11.3: Morphological changes in breast at puberty

During pregnancy there is an active development of both ducts acini (Many acini are formed for first time).

The breast enlarge and their vascularity increases. The acini secrete a small amount of glairy fluid (colostrum). The development of breast during pregnancy is endocrine hormone (oestrogen + progesterone) dependant for full preparation for Lactation is also dependant on an adequate diet, corticosteroids and prolactin (placental or pituitary) (Fig. 11.4).

At menopause, as the level of sex steroid hormones decrease, the breast tissue, both glandular and stromal undergoes atrophy. The breast size will decrease and this may also contribute to psychological disturbance during menopause. Breast is also an important secondary sexual organ and it is an erogenous zone, the stimulation of which aids in orgasm. Breast give the women a female identity, hence changes in breast size and problems of breast cause a lot of psychological upset and trauma.

#### DEVELOPMENTAL ANOMALIES OF BREAST

The breast development may show various anomalies which are seen during the adolescence growth period and cause a lot of psychological trauma.

The breast anomalies are classified as:

1. Congenital Anomalies
  1. Absence
  2. Supernumerary
  3. Ectopic position (Accessory breast/Nipple)
  4. Midline webbing
  5. Retracted Nipples
2. Modification of Physiological response
  1. Hypoplasia or Aplasia
  2. Hypertrophy

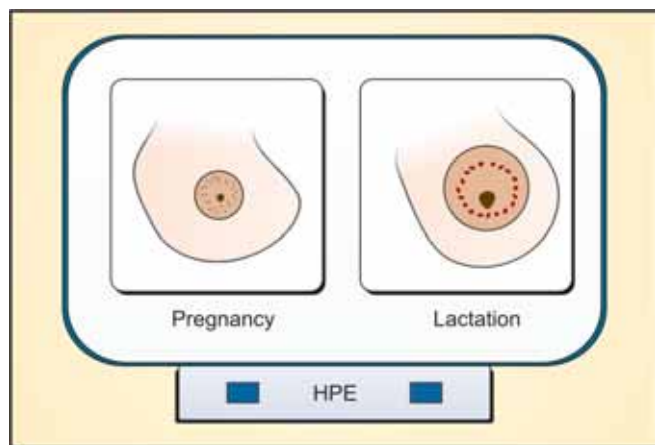


Fig. 11.4: Breast enlargement in pregnancy and lactation

3. Asymmetry
4. Painful engorgement (Neonatal or pubertal)
5. Malformation of shape
3. Faulty sexual development
  1. Premature development
  2. Delayed or failure of development

#### 1. Congenital Anomalies

1. Absence
  - a. Amastia: absence of complete breast
  - b. Athelia: absence of nipple
  - c. Amazia: nipple is formed but not breast tissue
2. Supernumerary
  - a. Polymastia: multiple breast
  - b. Polythelia: multiple nipples
  - c. Polythelia areolaris : only multiple areolas
  - d. Only glandular tissue
3. Ectopic position of nipple or breast (accessory breast and nipples)
4. Symmastia: Midline webbing between breasts

Congenital breast anomalies should be indentified early and mostly reassurance is needed and counselling is needed for corrective surgery in most cases. The surgeries done for such anomalies are augmentation mammoplasty, surgical removal of supernumerary breast or nipples, mammary prosthesis or glandular flap for unequal breasts.

#### 2. Modification of Physiological response

1. *Aplasia or Hypoplasia*: Varying degree of under developed breasts are seen in young women and is usually due to fat and glandular tissue. The treatment for hypoplasia ranges from good diet, excercises of pectoral muscles, massage, oestrogen therapy in cases of low ovarian oestrogens and plastic surgery.
2. *Hypertrophy*: True hypertrophy (not adiposity) is uncommon. The cause is not known and it affects glandular tissue and not nipples. Usually bilateral and seen at puberty. These breasts may weigh as much as 6-13 kgs. These breasts will further hypertrophy during pregnancy and lactation but they do not lactate. Treatment is support or surgical reduction (subtotal mastectomy). Bromocriptine may be of some benifit during pregnancy.
3. *Asymmetry*: Like all other paired organs breast also will show some inequality in size (In 7% Adolescent which disappears later). Breast measurement is done with a centimetre tape from

3 O' clock to 9 O' clock and then from 12 O' clock to 6 O' clock over the nipples. The two measurements are multiplied and the figure is called "breast unit" Right breast normally tends to be slightly larger than left breast (Table 11.2).

Table 11.2: Breast unit

Age	Rt Breast		Left Breast	
	Measure (cm)	Unit	Measure (cm)	Unit
14	19 × 13	247	18 × 14	252
15	21 × 17	357	17 × 20	340
16	22 × 18	396	18 × 21	378

The fault of asymmetry of breasts is always inherent fault in target tissue hence endocrine treatment is of no value. If the asymmetry is too much then surgery is the only answer (usually reduction of the larger breast and sometimes enlargement of the smaller).

4. **Painful engorgement (Mastitis) (Neonatal or Adolescent):** Breasts of male or female babies sometimes become enlarged and hard 3-4 days after birth. This is due to congestion related to the withdrawal of the influence of maternal oestrogens. A discharge may also occur from the nipple, known as "witch's milk". No treatment is required.

Adolescent mastitis is a nodular painful enlargement of breasts in both boys and girls. It is due to an upsurge of pituitary hormones. No treatment is required. Reassurance and sometimes analgesics for symptom relief. A well fitting brassiere for breast support.

5. **Malformation of shape:** Usually the malformation involving inferior quadrant will present with various degree of severity. Minor malformations are high submammary sulcus, hypoplasia of inferior quadrant. Major malformations are flatness of whole inferior quadrant leading to "Funnel breast" or "Tubular breasts" also known as "nipple" breast or "snoopy" breasts. Surgical correction is the only treatment (Fig. 11.5).

### 3. Faulty Sexual Development

1. **Premature development:** where breast growth starts before the age of 8 years (Premature the larche), is due to increased organ sensitivity. This is usually self limiting.

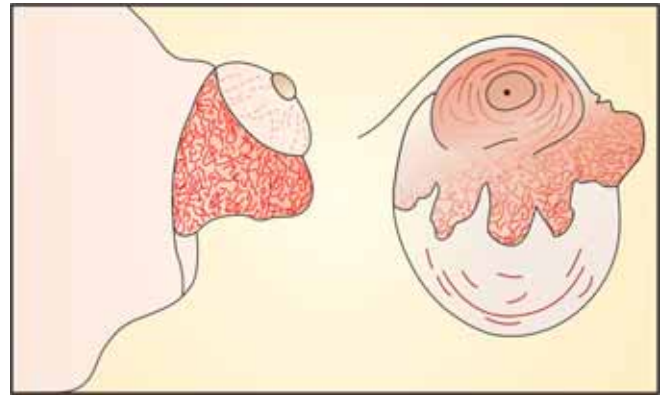


Fig. 11.5: Tubular breast: excision of glandular tissue

If breast growth is associated with other secondary sexual characters and menstruation then it is known as "precocious puberty".

2. **Delayed or failure of development of breast:** Absence of breast growth by age of 14 years is regarded abnormal.

If menses is normal then it is hypoplasia due to target organ receptor. If amenorrhoea is there then the causes could be gonadal dysgenesis, pituitary hypothalamic lesion or androgen producing tumours.

Complete endocrine and genetic investigations with CT skull may be required.

3. **Changes in pregnancy and lactation:**

The mature breast is a collection of sweat glands modified during evolution to produce milk. Developed breast (mammary gland has stroma and glands which consist of fat, connective tissue, ducts and lobuloalveolar system. Breasts undergo mammogenesis during pregnancy.

#### Anatomic Changes

- General enlargement upto 2 to 3 times
- Increased vascularity and engorgement of superficial veins
- Brown pigmentation of areola
- Raised areas of areola: Montgomery's tubercle
- formation of secondary areola
- Increased erectility of breasts
- Nodularity of breasts
- Secretion of a glairy fluid (colostrum)
- Pain and tenderness

Anatomic changes are more pronounced in primigravida rather than multigravida.

### Physiological Changes

1. Mammogenesis
2. Lactogenesis
3. Galactokinesis
4. Galactopoiesis

The preparation of breasts (Mammogenesis) begins during pregnancy. Synthesis and secretion of milk (Lactogenesis) occurs due to high prolactin and fall in oestrogen and progesterone after delivery of placenta. The hormones responsible for mammogenesis or lactogenesis are cortisol, growth hormone, thyroxine and insulin.

Galactokinesis is a centrally mediated reflex of milk let down. Galactopoiesis is maintenance of lactation and depends on frequent suckling of breast by infant.

### 4. Breast Feeding and Lactation

Breast milk is universally recognised as the preferred nutrition for infants. Exclusive breast feeding is promoted internationally as optimum feed upto 4-6 months. Breast milk is nutritionally and immunologically superior to any substitute.

The advantages of breast feeding to infant are nutrition, fat demand of baby, lactose content, protein content, vitamins and minerals, protective role against infections (due to IgA, lactoferrin, bifidus factor, unsaturated fatty acids, antibodies, lacto-peroxidase, interferons and chemotactic factor).

Breast feeding also has benefits for the mother.

1. Breast feeding women return to prepartum state faster
2. Low risk of long term osteoporosis
3. Lower risk of premenopausal breast cancer
4. Inhibits ovulation hence contraceptive value.

Other advantages are:

- a. Economic
- b. Benefits to community and country
- c. Ecologic benefits
- d. Psychological advantages
- e. *Other benefits to baby:* Minerals, protective role, lactoferrin, bifidus factor, unsaturated fatty acids, antibodies and non specific factors against viruses, other cellular components, development of brain and CNS.

The Benefits of breast feeding also extend to the mother and these are:

1. Faster return to prepartum state
2. Low risk of long term osteoporosis
3. Lower risk of premenopausal breast cancers
4. Exclusive breast feeding, inhibits ovulation and hence delays return of fertility (contraceptive benefits).
5. The other benefits are economic, benefit to community and country, ecologic and psychological.

The role of health care professionals is very important in initiating breast feeding in women during the first few days of hospital stay. WHO and UNICEF have also launched Baby Friendly Hospital Initiative (BFHI) in India and as a part of global effort to protect, promote and support breast feeding.

### Special Conditions

Breast feeding can be reliably continued in various maternal health problems, except in heart failure, severe lung and kidney diseases and severe psychosis or postnatal depression. Mastitis and breast abscess do not contraindicate breast feeding. In mothers suffering from open tuberculosis, breast feeding can be continued and infant should be given prophylactic isoniazide. Breast milk is a primary form of immunisation for the infant hence in HIV and Hepatitis B infected mothers the benefits outweigh the risk of transmission.

Maternal malnutrition does not affect breast milk, however extreme prematurity and bilateral cleft palate may be a contraindication.

### Breast Diseases in Lactation

The most common problem during lactation is mastitis and abscess formation. Mother may develop tender painful masses of galactoceles which can be diagnosed and cured by aspiration. Fibroadenomas may enlarge and become painful due to infarct.

Breast cancer diagnosis becomes delayed if it occurs during lactation.

### Failure of Lactation

Lactation fails if not initiated by early suckling. In 70 per cent cases lactation can be restored by counselling, good nutrition, rest and frequent suckling.

If there is complete failure (agalactia) or very less breast milk, then galactogogus may be tried (chrompropazine or metoclopramide).

Also it is possible to induce breast milk in non puerperal mothers.

**SUPPRESSION OF LACTATION**

In some conditions breast milk needs to be suppressed in about 60-70 per cent. This can be achieved by no suckling and breast support. Drugs used for suppression are oestrogen and progesterone and androgen combination. This combination can reduce engorgement and discomfort but there is a risk of thromboembolism and rebound engorgement. Pyridoxine is a cheap and effective drug for lactation suppression. Bromocriptine is effective but has side effects. Cabergoline in a single 1 gm dose is very effective.

**DRUGS AND LACTATION**

Safety of prescribing any drug during lactation is questioned and a through knowledge of pharmacokinetics excretion in breast milk and probable hazards to infant should be kept in mind. Drug therapy beneficial to mother and not detrimental to infant is ultimate goal. Tables 11.3 to 11.8 includes safe and unsafe drugs.

**ENDOCRINE DISORDERS (GALACTORRHOEA AND BREAST ATROPHY)**

**Galactorrhoea**

About 5-10 per cent of normally menstruating women and 22 per cent of infertile women have milky discharge

**Table 11.4: Ratio of drug distribution in milk/plasma**

Drug Type	M:P Ratio
Lipid soluble	+1
Water soluble (with MW 200)	+1
Weak acids	=<1
Weak bases	=>1
Actively transported drugs	>1

**Table 11.5: Drugs contraindicated in lactation**

<ul style="list-style-type: none"> <li>• Antineoplastic</li> <li>• Diazepam</li> <li>• Lithium</li> <li>• Phenindione</li> <li>• Radiochemicals</li> </ul>
--

**Table 11.6: Drugs with limited safety in lactation**

Anthraquinones	Nalidixic acid
Barbiturates (safe in low doses)	Oral contraceptives (safe in low doses)
Cimetidine	Phenylbutazone
Indomethacin	Reserpine
Isoniazid	Sulphonamides
Methyldopa	Tetracycline
Metronidazole	Thiazide diuretics

**Table 11.3: Factors affecting drug transfer into milk**

<i>Maternal pharmacology</i>
Drug dose, frequency and route of administration
Clearance rate
Plasma protein binding
Metabolite profile
<i>Breast</i>
Blood flow and pH
Yield capacity
Ion nd other transport mechanism
<i>Milk</i>
Composition (Fat, Protein, Water)
<i>Infant</i>
Suckling time and amount/feed
Feeding intervals
<i>Drug</i>
PKa
Solubility characteristics in fat
Protein binding characteristics, molecular weight

**Table 11.7: Probable safe drugs in lactation**

Alcohol	Erythromycin	Nitrofurantion
Ampicillin	Folic acid	Paracetamol
Antihistamines	Frusamide	Penicillin
Caffeine	Gentamycin	Pentazocine
Carbamazepine	Guanethidine	Pethidine
Carbenicillin	Heparin	Phenothiazines
Cephaloridine	Heroin	Potassium iodide
	Imipramine	Propanthelene
Chlordiazepoxide	Iron	Quinine
Chloroquine	Kanamycin	Salicylates
Chlorpromazine	Lincomycin	Sodium fucidate
Codeine	Mefenamic acid	Streptomycin
Desipramine	Methylergometrine	Thyroxine
Dichloralphenazone	Morphine	Tolbutamide
Digoxin	Nitrazepam	Warfarin

Table 11.8: Analgesics and anti-inflammatory drugs

Drug	Quantity in Milk	MP Ratio	Adverse effects(Infant)	Comments
Aspirin	Trace	<1	Platelet	Cautious use
Mefenamic acid	Negligible	—	NS*	Compatible
Indomethacin**	Excreted	0.37	Seizures and may be nephrotoxic	Compatible
Morphine	Trace	—	Neonatal addition in high doses	Compatible
Phenylbutazone	Trace	0.13	NS*	Compatible
Pentazocine	Not excreted	None	NS*	Compatible

\*NS—Not significant  
\*\*Case report

from breast nipples known as galactorrhoea. Milk discharge from nipples can be scanty or abundant expressed or spontaneous, intermittent or persistent and unilateral or bilateral. Galactorrhoea needs to be evaluated in nulliparous women and in women who have stopped breast feeding for a year. Nipple discharge can be confirmed as milk by examining on a slide with coverslip under a microscope to see for fat droplets.

*Prolactin* is a polypeptide secreted from anterior pituitary gland and also by chorion, endometrium and decidua. Normal midmorning fasting levels of prolactin are 0-20 ng/ml. Prolactin release is in pulses every 1-1.5 hrs more in night time (circadian rhythm). Secretion is highest from midnight to 6 am.

Prolactin secretion is affected by eating, stress (physical or mental) exercise and sexual intercourse (But rarely more than 30 ng/ml).

In pregnancy levels may increase upto 100 - 200 ng/ml i.e. 5 to 10 times from 10th week onwards and during postpartum levels may go up by 15 times i.e. upto 300-600 ng/ml. The figure 11.6 shows how prolactin hormone is regulated.

**Pathophysiology of Galactorrhoea**

The final pathway for milk discharge from breast is an oestrogen primed breast and hyper prolactinaemia. All cases of hyperprolactinaemia may not have galactorrhoea (28%). Idiopathic galactorrhoea may occur without a prolactin rise and 1/3 of these women may menstruate normally.

**Causes of Galactorrhoea (Table 11.9)**

Most common cause is due to pituitary tumours (seen in 40% cases) and due to drugs.

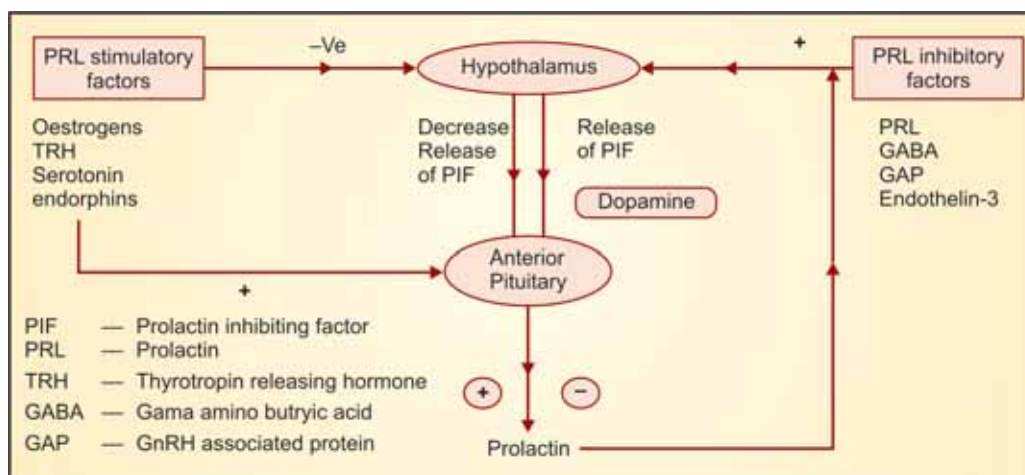


Fig. 11.6: Control of prolactin secretion

Table 11.9: Causes of galactorrhoea

Cause	Mechanism
I. Pharmacological	Certain drugs
II. Persistent breast stimulation	Neurogenic reflexes from chest and nipples to CNS decrease PIF and release oxytocin
III. Chest lesions: Thoractomy scars Herpes zoster, cervical spinal lesions	
IV. Hypothalamic dysfunction Chiari Frommel syndrome (Galactorrhoea persists after delivery) Del-Castillo syndrome (Galactorrhoea without antecedent delivery)	Psychogenic disturbance alters brain transmitters which decrease PIF
V. Forbes Albright syndrome (it signifies organic brain lesion)	
A. Pituitary tumour: Prolactinomas (Micro and Macro), Mixed growth hormone/PRL secreting (acromegaly), Mixed ACTH/PRL secreting (Cushing's disease)	Hyper-secretion of prolactin
B. Non-pituitary lesions Craniopharyngioma, empty sella syndrome, other tumours: (Pinealoma, meningioma, astrocytoma metastasis, neurofibromatosis head trauma, encephalitis)	Pituitary stalk compression
VI. Primary hypothyroidism	TRH stimulates PRL release
VII. Renal disease	Decreased excretion of PRL
VIII. Ectopic prolactin secreting tumours: Bronchogenic carcinoma, hypernephroma leiomyoma	Ectopic prolactin secretion
IX. Idiopathic	

PRL = Prolactin  
PIF = Prolactin inhibiting factor  
ACTH = Adrenocorticotrophic hormone  
TRH = Thyrotropin releasing hormone

### Clinical Features

- Oligomenorrhoea
- Amenorrhoea
- Dysfunctional uterine bleeding
- Luteal phase defects
- Infertility
- Hirsutism
- Osteoporosis

### Diagnosis

All preliminary routine mandatory investigations to include serum prolactin, thyroid and renal function tests.

A serum prolactin should be done on two occasions as a mid-morning fasted, non stressed, no drugs and in follicular phase of menstrual cycle (Table 11.10).

### Table of Levels

Screening for pituitary tumours is done by imaging sella turcica by the various imaging modalities as shown in table 11.11.

Table 11.10: Correlation of PRL levels in non-pregnant non-lactating women

Prolactin levels (ng/ml × 43.86 = /Pmol/ml)	Probable diagnosis
≤ 20 ng/ml	Normal
20-100 ng/ml	Functional or tumour
100-200 ng/ml	Very suggestive of a tumour
200-300 ng/ml	Tumour present in 90% of cases
>300 ng/ml	Tumour is invariable

Endocrinal tests to discriminate hypothalamic and pituitary causes.

- GnRH stimulation
- TRH stimulation

Endocrine tests do not give any more additional value than a coned down view of sella turcica.

Visual field examination is not useful as these may be altered only in very big tumours which are evident by radiological examination.

**Table 11.11: Imaging techniques of sella-turcica**

<i>Lateral coned down view of sella turcica</i>	<i>Computer axial tomographic scan in coronal plane with intravenous contrast (Enhancement CT Scan)</i>	<i>Magnetic resonance imaging (MRI)</i>
<p>Detects macroadenoma and craniopharyngioma</p> <p><i>Advantages</i></p> <p>Cheap and easily available</p> <p><i>Disadvantages</i></p> <ul style="list-style-type: none"> <li>• It is not very sensitive for small tumours as interpretation is dependent upon bony changes occurring in sella turcica secondary to tumour enlargement</li> <li>• In large tumours it cannot detect suprasellar extension</li> </ul>	<p>Uses 1 mm slices of the pituitary gland and hypothalamus. It visualises pituitary tissue and surrounding soft tissue. Therefore, it can diagnose microadenoma, suprasellar extension and empty sella syndrome</p> <p><i>Disadvantages</i></p> <ul style="list-style-type: none"> <li>• High cost</li> <li>• Radiation exposure which is 3 rads, to eye lens it is 7 rads</li> </ul>	<p><i>Best imaging technique for sella turcica</i></p> <p>It gives resolution of 1 mm, more sensitive than CT. Scan gives better accuracy in assessing extrasellar extension and empty sella syndrome. It has no biologic hazard</p> <p><i>Disadvantages</i></p> <ul style="list-style-type: none"> <li>• Very expensive</li> <li>• Requires lengthy period of time to obtain images</li> </ul>

**Treatment**

Treatment depends on aetiology, stop aggravating drug, treat hypothyroidism, chest lesions and renal disease.

If pituitary tumour is diagnosed, there are three options: medical, radiation or surgery.

In cases of microadenoma only close surveillance in non-infertile parous women is a treatment option.

**Breast Atrophy**

Breasts are symbolic of femininity and maternal and sexuality not well formed breast and small atrophic breasts after puberty have a psychological feeling of disfigurement, loss of womanhood, social rejection or isolation. Breast atrophy or deformity is the most emotionally devastating of the physical deformities in women.

*Classification*

- A. Developmental breast hypoplasia (Micromastia)
  - i. Congenital
  - ii. Iatrogenic
- B. Late onset breast atrophy
  - i. Postpartum
  - ii. Postmenopausal
  - iii. Secondary breast atrophy
  - iv. Idiopathic

**Aetiology**

Table 11.12.

**Table 11.12: Causes of small breasts**

<i>Clinical type</i>	<i>Causes</i>
1. Developmental breast hypoplasia	1. Congenital 2. Iatrogenic in pre-pubertal age <ul style="list-style-type: none"> <li>• Trauma</li> <li>• Infections</li> <li>• Incision</li> <li>• Radiation therapy</li> </ul>
2. Late-onset breast atrophy <ul style="list-style-type: none"> <li>a. Postpartum atrophy</li> <li>b. Postmenopausal atrophy</li> <li>c. Secondary atrophy</li> </ul>	Hormonal Oestrogen deficiency 1. Endogenous factors <i>Neoplasms</i> <ul style="list-style-type: none"> <li>• Adrenal and ovarian tumours</li> </ul> <i>Non-neoplastic conditions</i> <ul style="list-style-type: none"> <li>• CAH*</li> <li>• Late onset CAH</li> <li>• Cushing's syndrome</li> <li>• PCOD**</li> </ul> 2. Exogenous-drug induced <ul style="list-style-type: none"> <li>• Androgens and anabolic steroids</li> <li>• Danazol, dilantin</li> <li>• Minoxidil, diazoxide</li> <li>• Oral contraceptives</li> </ul>
d. Idiopathic	Unknown viral
*CAH — Congenital adrenal hyperplasia **PCOD — Polycystic ovarian disease	

*Clinical Features and Evaluation*

- Age (Adolescent, Post-pregnancy, Post-menopausal)
- History (weight loss or gain)



- Development (puberty/pregnancy/lactation)
- Endocrine (secondary sex characters)
- Breast masses
- Family history of breast cancer
- Psychological
- Medical diseases

In secondary breast atrophy:

- Virilism
- CAH or Cushing's disease
- Ovarian tumours

*Laboratory Tests*

1. 17 ketosteroids and hydroxy ketosteroids in urine
2. Plasma testosterone and free testosterone
3. Plasma androstenedione, LH, FSH, PRL
4. Adrenal and Ovarian vein studies
5. CAT Scan and MRI
6. Ultrasound
7. Laparoscopy

**Management**

Look for underlying causes in adolescent group and treat them however to increase breast size. Mammary augmentation surgery is required.

The figure 11.7 highlights the management of small breasts.

**SCREENING FOR BREAST DISEASES**

In the western countries breast cancer is the foremost killer. The incidence is as high as one in nine women. In India breast cancer is second to cervical cancer in incidence and mortality.

To reduce mortality early detection is essential and statistics show that by screening mortality can be reduced by 25 per cent.

**Risk Factors**

Twenty per cent in 30-54 years age group and 29 per cent in women aged 55-84. Every woman is assumed at risk and must be screened.

*Age:* At the age of 70 years a woman has 10 times more risk than 40 year old.

Screening will benefit women 50-69 years most as there will be a 29 per cent reduction in mortality.

Recommended screening is two yearly mammography (National cancer Institute)

As the incidence of breast cancer is less than 10 per cent before 40 years these women benefit maximum by screening.

**Genetics (familial)**

Almost 5-10 per cent of breast cancer is seen to have a familial pattern over many generations. The relative risk

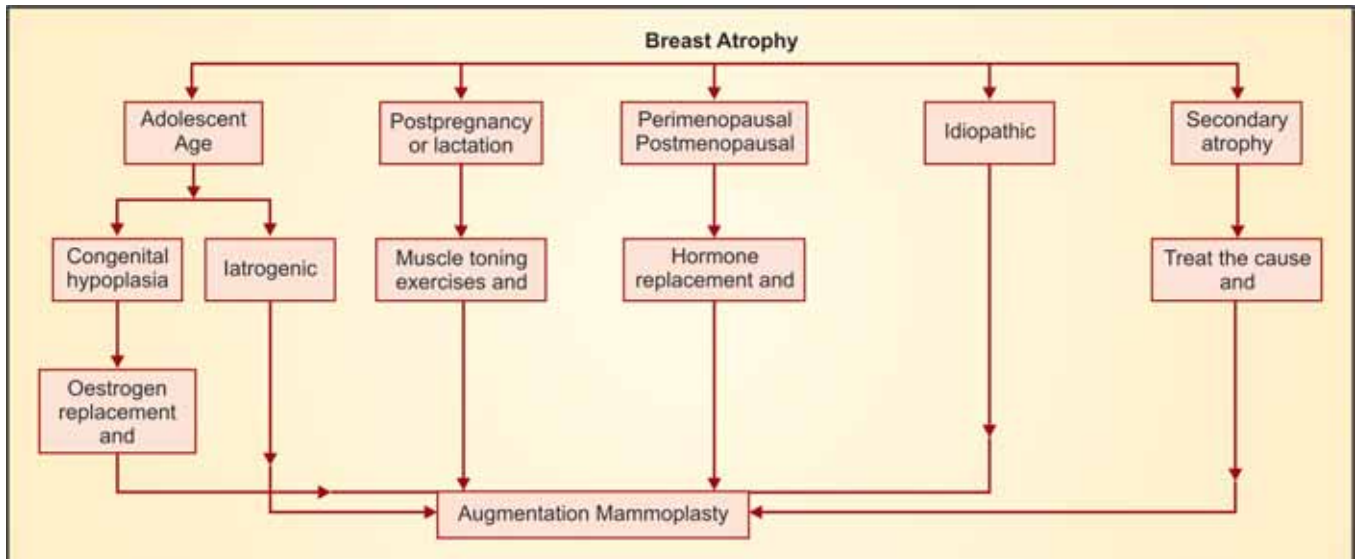


Fig. 11.7: Management of breast atrophy

is 1.5 to 2 with one first degree relative and 4-6 with two first degree relatives.

BRCA-1 gene on the long arm of chromosome 17 and BRCA-2 on chromosome 13 and mutation p53, the tumour suppressor gene are implicated.

### Reproductive Factor

Early menarche is a weak risk factor, relative risk of 1.2 for women with a menarche before 12 years as compared to 14 years. Chinese women have a 5 times less risk of breast cancer as compared to American women as the menarch is 17 years. Incidence is doubled in women with natural menopause occurring after 55 years. Nulliparity and delay of first child birth are also risk factors, increasing the risk by 3.5.

Lactation is a weak to moderate protector.

### BENIGN BREAST DISEASE

Women with history of benign breast disease contribute to 5 per cent of breast cancer cases.

*Diet/obesity/Alcohol:* High fat contents in diet may influence, obesity is not a major risk factor. Alcohol consumption of even one drink per day is a moderate risk factor.

*Hormones and Breast Cancers:* Oestrogen and very long term use of oral pills appear to increase risk but the risk drops as soon as drug is stopped.

*Ionising Radiation:* No increase of risk in low dose exposure as low dose screening mammography. Risks increased from atomic blast exposure (Japanese women), radiation exposure for postpartum mastitis, tubercular patients undergoing multiple fluoroscopy.

### Screening Strategy

Screening is basically done by:

1. Breast self examination (BSE) (every month)
  2. Clinical examination by Physician (Annually)
  3. Screening mammography (every two years)
1. *BSE:* Should be done every month after a menstrual period when breasts are soft (Fig. 11.8).

The woman is asked to uncloth to waist and sit in front of a mirror:

1. Hands by the side
2. Hands pressed against the hips
3. Hands above the head
4. Stooping forwards

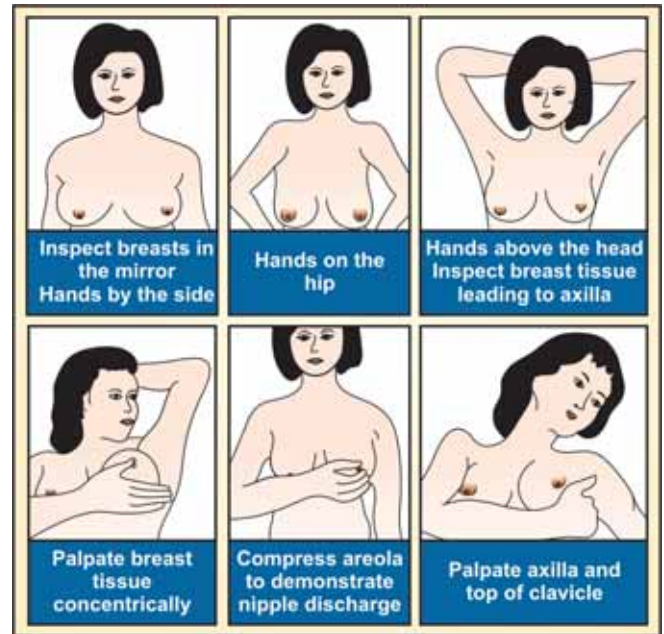


Fig. 11.8: Routine breast self examination

The woman is taught to look for changes in size, contour, nipple retraction, elevation, visible lumps, skin changes like erythema, dimpling, ecchymosis. Breast should fall forwards on stooping.

The woman should palpate after inspection in both sitting and supine position. Palpate right breast with left hand and vice versa. Teach the woman to palpate using palmar surface and areola is compressed to demonstrate nipple discharge, and then feel supraclavicular area.

2. *Clinical examination by Physician:* A complete and thorough history, assesment of reproductive history, counselling handing out pamphlets and reteaching BSE. The clinical examination is same as BSE but done by the physician.

### Screening Mammography

The breast imaging can be done by ultrasound (high resolution probes) or radiologically by mammography. (Film screen mammography or xeromammography).

For screening purpose breast mammography should be done every two years.

Breast ultrasound is done by a 5-7.5 MHz transducer. The entire quadrant is scanned in sagittal and transverse planes.

Both film screen and xeromammography are sensitive techniques in evaluating breast diseases.

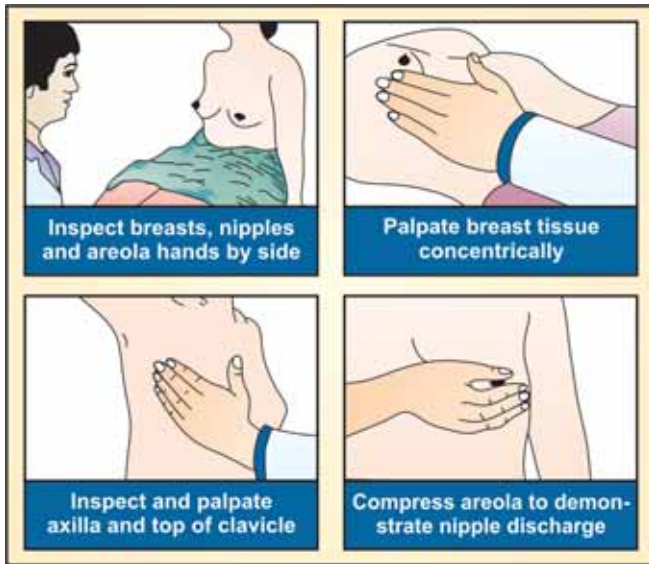


Fig. 11.9: Breast examination by physician

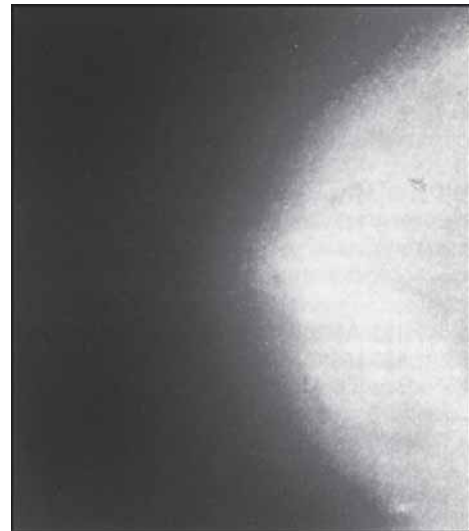


Fig. 11.10: Mammogram shows diffuse increased density with no evidence of calcification. Benign breast disease

**Film Screen Mammography** has a sensitivity of 90 per cent. It is the only method that allows reproducible and reliable detection of a prognostically relevant non palpable carcinoma. Xeromammography provides good penetration specially in dense breasts (Fig. 11.10). The procedure is dry, quick and does not need a darkroom, but only 5 per cent of mammograms are performed with xeromammography due to high dose of radiation and some technical disadvantages.

**Ultrasound:** Today high resolution ultrasound with high frequency probes and the newest introduction of elastography (still under trial as screening for breast

cancer) has revolutionised breast imaging ultrasound is becoming indispensable after a clinical examination. Ultrasound is quick, reliable and cheap and reproducible with patient comfort. Also almost all interventional procedures for diagnosis in breast disease are now done under ultrasound guidance (Fig. 11.11).

**Thermography** shows thermal asymmetry and an abnormal thermography indicates

- A localised abscess or inflammation
- Alveolar lesions.

**Diaphanography** is based on identifying lesions using transillumination.

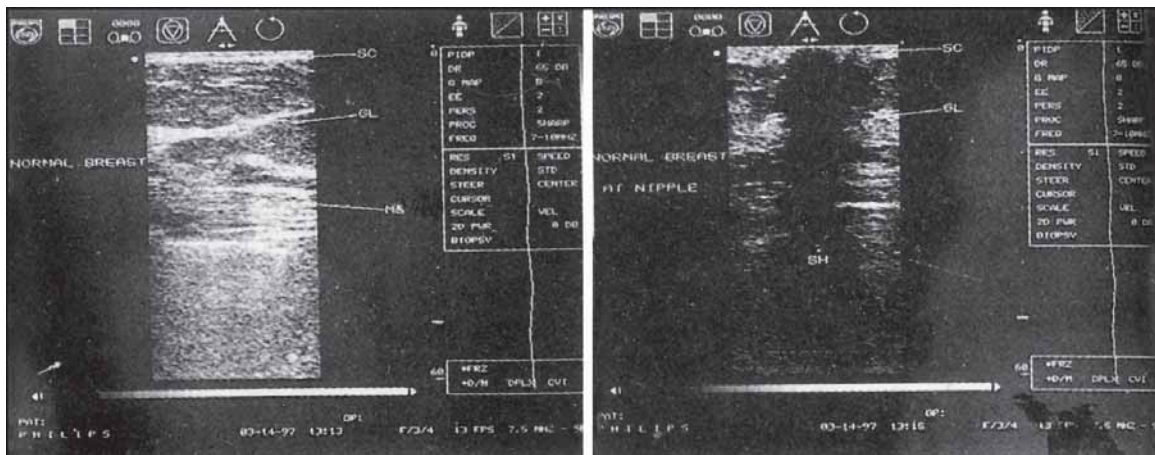
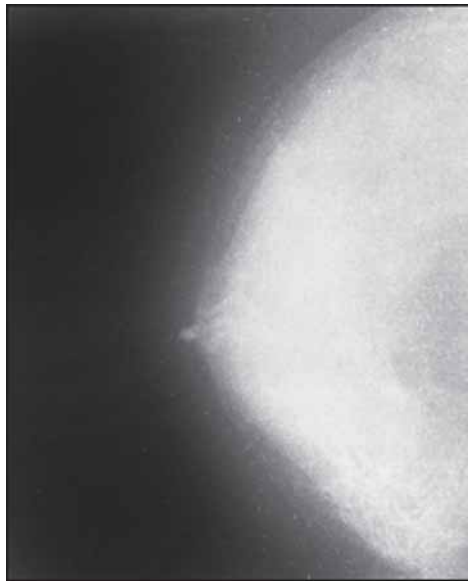


Fig. 11.11: Ultrasound shows normal anatomy

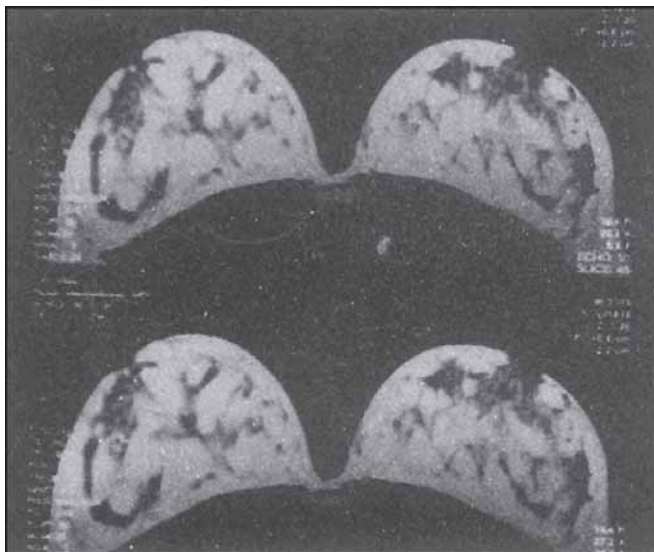


**Fig. 11.12:** Galactography—shows normal and dilated ducts in otherwise normal mammography but H/o nipple discharge

*Pneumocystography* may tell us the extent of intracystic tumour.

*Ductography/Galactography* is done by injecting radiographic dye into mammary ducts (Fig. 11.12).

Abnormalities of nipple discharge like ductal ectasia, fibrocystic changes, papillomas and intraductal carcinoma can be diagnosed.



**Fig. 11.13:** MRI—shows normal breast, T<sub>1</sub> and T<sub>2</sub> weighted image

*CAT Scan* is of no use in evaluating breast lesions.

*MRI:* A contrast enhanced MRI is most sensitive additional imaging modality after ultrasound and mammography (Fig. 11.13).

*Others:* Digital Imaging and PET (Positron Emission Tomography) are being evaluated.

### Breast Cancer Screening

Aims of screening for any cancer is to decrease the mortality and detect cancer before they become symptomatic. Mammography is the most sensitive method.

Feig's imaging protocol		
SN	PT Age years	Imaging
1.	< 20	Sonography alone
2.	20-30	Sonography + Mammography
3.	30-35	Sonography + Mammography
4.	> 35	B/L views per breast mammography then sonography and MRI

### BENIGN BREAST DISEASES

- a. Mastodynia
- b. Fibrocystic disease
- c. Benign tumours

a. *Mastodynia or Mastalgia or Breast pain:* can be cyclical or non-cyclical. Cyclical pain in breasts may occur related to menstrual cycle in the week preceding menstruation and is usually due to benign mammary dysplasia.

Non-cyclical breast pain is more common and is usually in pre or post menopausal women. The pain is dragging or burning like pain. A mammography usually reveals coarse calcifications and ductal dilatations

Pain in breasts may also be due to sclerosing adenosis, breasts cancer and Tietze's syndrome.

Breast pain is best managed by reassurance, a thorough clinical examination ultrasound and mammography.

Supportive therapy helps like a good supporting Bra, low caffeine and mild anti-inflammatory drugs. Hormone therapy in form of use of Progesterone, Bromocriptine, Tamoxifen, Danazol, Gestrinone, Lisuride Maleate, LHRH analogues and thyroid hormone have been tried.

Use of Evening primrose oil, Vit E and Diuretics may also help.

Table 11.13: TNM system of classification and staging

Breast: Left Right

Tumour Size \_\_\_\_\_ cmx \_\_\_\_\_ cmx \_\_\_\_\_ cm

Lymph nodes total no      No with metastasis

Definitions:

*Primary tumour (T)*

TX	Primary tumour cannot be assessed
T0	No evidence of primary tumour
Tis	Carcinoma in situ: Intraductal carcinoma, lobular carcinoma in situ, or Paget's disease of the nipple with no tumour
T1	Tumour 2 cm or less in greatest dimension
T1a	0.5 cm or less in greatest dimension
T1b	More than 0.5 cm, but not more than 1 cm in greatest dimension
T1c	More than 1 cm but not more than 2 cm in greatest dimension
T2	Tumour more than 2 cm but no more than 5 cm in greatest dimension
T3	Tumour more than 5 cm in greatest dimension
T4	Tumour of any site with direct extension to chest wall or skin
T4a	Extension to chest wall
T4b	Edema (including peau d' orange) or ulceration of the skin of breast or satellite skin nodules confirmed to same breast
T4c	Both T4a and T4b
T4d	Inflammatory carcinoma

*Regional lymph nodes (N)*

NX	Regional lymph nodes cannot be assessed (e.g. previously removed or removed for pathologic study)
N0	No regional lymph node metastasis
N1	Metastasis to movable ipsilateral axillary lymph node(s)
N2	Metastasis to ipsilateral axillary lymph nodes that are fixed to one another or to other structures
N3	Metastasis to ipsilateral internal mammary lymph node(s)

*Distant Metastasis (M)*

MX	Presence of distant metastasis cannot be assessed
M0	No distant metastasis
M1	Distant metastasis (includes metastasis to ipsilateral supraclavicular lymph node(s))

Table 11.14: Management depending on stage of carcinoma

Stage		In all cases	Special staging tests
I	T1N0	CBC urinalysis LFT, KFT X-ray chest, EKG Mammogram USG abdomen	Bone scan CT/MRI only if indicated
IIA	T1N1 T2N0	-do-	-do-
IIB	T2N1 T3N0	-do-	Bone scan selective vs. universal
IIIA	T0-T3, N2	-do-	Bone scan in all cases CT/MRI if indicated
IIIB	T4 any N any T N3	-do- Mammogram	-do-
IV	any T any N M1	-do- Mammogram	Bone scan in all cases CT/MRI in all cases

b. *Fibrocystic disease*: is common and distressing to the women as it may last for years.

Fibrocystic disease is seen in one of four women with breast complaints may occur at any age. Aetiology is not clear may be hormonal disturbance, fluid retention, excessive caffeine and psychoneurosis.

Breasts may have any of the numerous presentations described like small cystic feel, diffuse cystic feel, lumpy breasts etc. Risk of cancer with fibrocystic disease is poorly understood with an odd ratio of 1:8. A thorough clinical exam with mammography and FNAC should be advised.

These women are best managed as per ABOG (American Board of obstetric and gynaecology) guidelines. After ruling out breast cancer the treatment is reassurance, pain killers, primrose oil, vitamin E, Danazol, bromocriptine, diuretics and pyridoxine. If no relief then progesterone therapy can be tried. The pain response and relief is charted by cardiff breast score.

c. *Benign Tumours of Breast*:

Breast lumps cause a lot of anxiety to patients and the possibility of malignancy is a challenging diagnostic dilemma.

Benign tumours of breasts may be:

1. Fibroadenoma
2. Giant fibroadenoma
3. Phyllodes tumours
4. Papilloma and ductal tumours
5. Intraductal papilloma
6. Juvenile papillomatosis
7. Nipple adenoma
8. other benign tumours
9. Adenomyoepithelioma
10. Hamartoma
11. Lipoma
12. Leiomyoma

These tumours are best treated by excision (Lumpectomy).

Emphasis on breast self examination should be a part of education to girls.

## CARCINOMA BREAST

Cancer Breast is the commonest cancer in women in Europe, USA and Australia and in India it is second commonest after cancer cervix.

The incidence has increased and almost one million women will have cancer breast every year.

### Risk Factors

- Genetic
- Reproductive history
- Diet
- Hormone usage
- Radiation exposure

### Clinical Features

Usually presents as an ill-defined lump in breast associated with indrawing of nipple.

Stage I: Discrete palpable lump of 2 cm or less

Stage II: Discrete lump less than 5 cm with palpable ipsilateral mobile axillary lymph node

Stage III: Large lump with local extension

- Skin ulcer
- Peaud' orange
- Satellite skin nodules
- fixed chest wall
- fixed ipsilateral lymph nodes

Stage IV: All the above features plus

- Supraclavicular lymph node
- Liver enlargement
- Krukenberg tumour
- Ascitis
- Pleural effusion
- Bone pains and swelling
- Headache and epileptic episodes
- Chronic cough and recurrent haemoptysis

*Diagnosis* is based on clinical examination and a thorough search should be made with all investigative modalities for extension and secondaries

*Staging* TNM staging and classification (Table 11.13).

*Investigations* are aimed to:

1. Confirm Diagnosis
2. Assess extent of disease
3. Predict response

### Modalities and Tests

1. Ultrasound
2. Mammography
3. FNAC
4. Doppler studies
5. Bone scan
6. CAT and MRI Scans
7. Hormone receptor studies

Management of breast cancers depends on the staging (Table 11.14).

# CHAPTER 12

## Development of the Urogenital System

The Gonad	189	Development of the Vagina,	
Wolffian System	190	Bladder and Urethra	194
Müllerian Ducts	191	Development of the Vulva	194
Mesenteries and Ligaments	193		

The development of the three primary layers of the foetus is described in Chapter 7. By the twenty-first day (7-somite ovum) the embryo is completely covered by ectoderm, and the primitive gut (endoderm) has acquired a mesentery which attaches it to the posterior wall of the body cavity (*coelom*). The lining of the latter develops from mesenchyme; between it and ectoderm is the mesoderm (Figs 12.1A to D). On either side of the root of the mesentery is the *intermediate cell mass* of mesoderm and one part of this proliferates to form the *urogenital ridge* or *nephrogenic cord*. This extends from the cervical to the caudal region of the embryo. With the exception of the vulva, lower vagina, bladder and urethra, all the organs of the genital and urinary systems develop in these ridges.

### THE GONAD

The mesenchymal cells of the coelom on the medial aspect of the intermediate cell mass and the underlying mesodermal cells proliferate to form a *genital ridge* which is apparent in the cervical and thoracic regions of the 4-5-week-old (4.5 mm crown-rump [C.R.] embryo). This elongated mass of undifferentiated cells is the sex gland anlage destined to become either the testis or the ovary. Sexual differentiation of the gonad is recognisable by the sixth week (17 mm C.R. embryo). The coelomic cells form the germinal (surface) epithelium and probably the cortex of the ovary; the underlying mesoderm gives rise to the medulla. At an early stage, connective tissue cords or septa develop to divide the undifferentiated cells into epithelial columns. These are probably mesenchymal downgrowths from the surface epithelium.

In the male, the epithelial columns or *primary sex cords* become separated from the surface epithelium by the development of the connective tissue *tunica albuginea*; they subsequently differentiate to form the seminiferous tubules, Sertoli cells and the interstitial cells of the testis.

In the female, the tunica albuginea does not appear at this stage, and the cords of epithelial cells break up into clumps and ultimately collect around the primordial ova to form primitive follicles. Secondary downgrowths (*Pflüger's tubules*) occur later and also contribute pregranulosa cells. So, although the ovarian stroma is

derived from basal mesoderm, all the granulosa and theca elements develop from coelomic epithelium. It is suggested that the differentiation of the mesenchyme cells into granulosa and theca cells is dependent on the presence of ova, each one of which acts as an organiser of the cells around it to form a primordial follicle. Oogonia become encapsulated with pregranulosa or granulosa cells by about the sixteenth to twentieth week; these cells are essential to their survival (see Fig. 3.1).

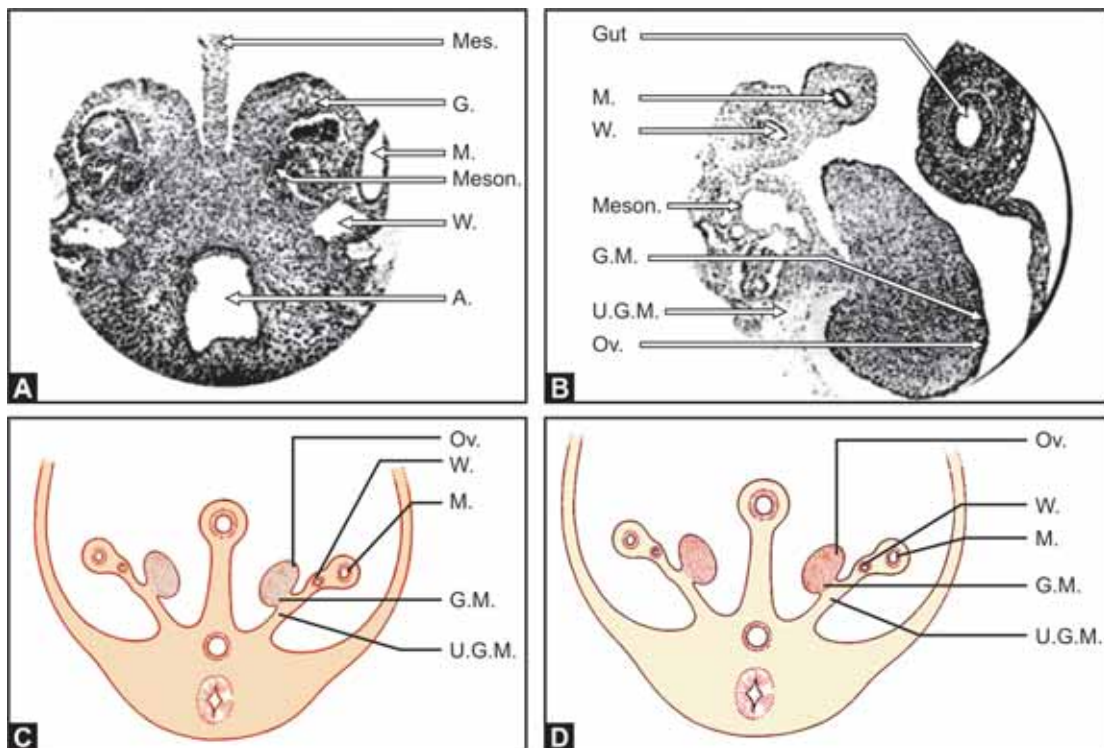
The primordial germ cells - oogonia and spermatogonia - are formed at a very early stage from cells of the dorsal part of the hindgut (originally yolk sac). Having a capacity for amoeboid movement, they migrate during the first 3 weeks of foetal development, passing through the mesentery of the gut to reach the gonad. Originally a limited number, the oogonia divide rapidly to produce, according to one estimate, 600,000 oocytes at 8 weeks, and 7 million at 22 weeks. Thereafter cell division ceases and, coincident with a proliferation of stroma, many, and particularly those which have not acquired a covering

of pregranulosa cells, are destroyed. Hence, the number of primary oocytes present in the ovaries at birth is not more than 2 million, and these are in the dictyate stage of meiotic division (see pages 56 and 58).

### WOLFFIAN SYSTEM

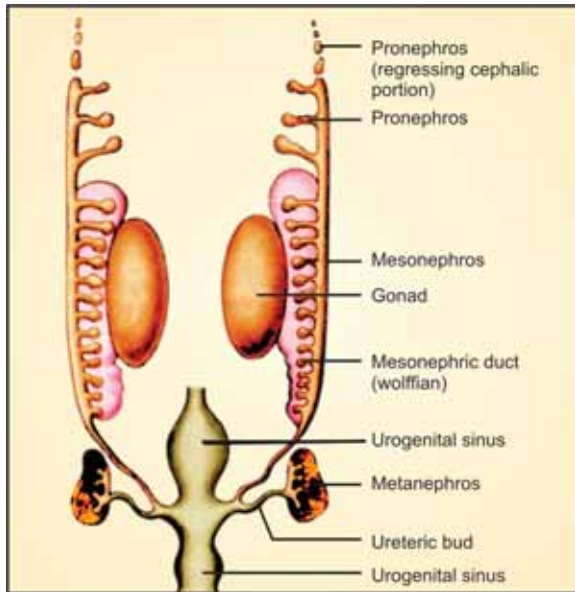
By the twenty-second or twenty-third day (8- or 9-somite ovum) small tubules develop in the cervical portion of each urogenital ridge, lateral to the future site of the gonad (Figs 12.1, 12.2 and 12.3). These constitute the *pronephros* and they acquire a duct which extends down to meet the *cloaca* which is the caudal extremity of the primitive gut. The pronephros is functionless and its tubules disappear almost entirely by the thirty-fifth day (10 mm C.R. embryo), their only remains in the adult female being the hydatid of Morgagni and possibly Kobelt's tubules (Fig. 12.5).

The *pronephric (wolffian) duct*, however, persists to serve the *mesonephros* - a second system of tubules which



**Figs 12.1A to D:** (A) Cross-section through the trunk of a 4-5-week-old embryo, showing the posterior coelomic wall with the root of the mesentery and the urogenital ridge on either side, (B) Similar cross-section through a slightly older embryo showing the left urogenital ridge and the mesentery of the gut. (C) Diagrammatic representation of (A), (D) Diagrammatic representation of (B), the right side being Jettered. Mes.-mesentery of gut; G-gonad; M-müllerian duct; W-wolffian duct; Meson.-mesonephric tubules; A-aorta; G.M.-genital mesentery; U.G.M.-urogenital mesentery; Ov-ovary





**Fig. 12.2:** Diagrammatic representation of the urogenital system in a 6-week-old embryo as seen from the front. The müllerian duct is not shown

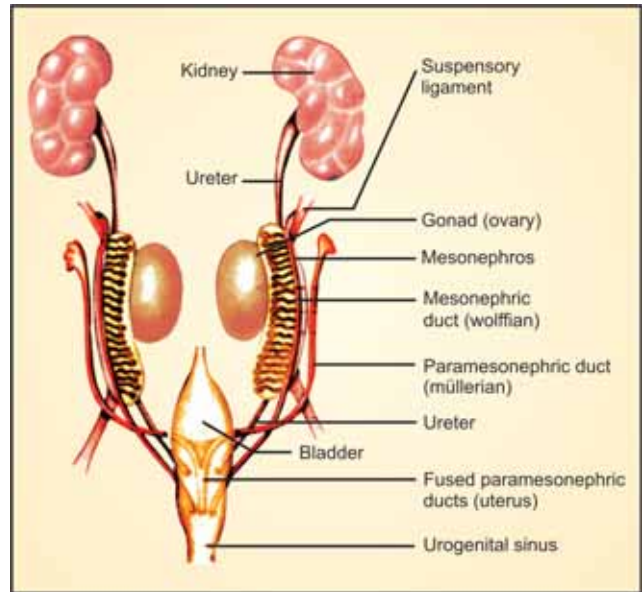
appears in the thoracic region on the twenty-ninth or thirtieth day (22-23-somite ovum).

The mesonephros also quickly degenerates, disappearing almost completely by the seventh week (22 mm C.R. embryo). A few caudal tubules persist as the functional vasa efferentia and rete of the testis in the male, and as the vestigial paroophoron, epoophoron (organ of Rosenmüller) and possibly Kobelt's tubules in the female (Figs 12.1, 12.2, 12.3, 12.4, 12.5 and 12.7).

A third system of tubules, the *metanephros*, first appears in the caudal portion of the urogenital ridge about the thirty-fifth day and develops into the cortex and medulla of the kidney. The calyces and pelvis of the kidney, together with the ureter, have a different origin, being formed from a bud which grows up from the lower end of the wolffian duct to meet the metanephros (Figs 12.2 and 12.3).

It will be noted that the kidney is at first situated at a low level in the foetal trunk. Its subsequent 'ascent' is more apparent than real, being mainly explained by disproportionate growth of the caudal end of the foetus.

The wolffian (pronephric and subsequently mesonephric) duct runs down the posterior coelomic wall in the urogenital ridge to join the forepart of the cloaca which, when separated from the hindgut, becomes



**Fig. 12.3:** The developing urogenital system as seen from the side

the urogenital sinus (Figs 12.3 and 12.7A to E). The lower end of the ureter, below and in the region of the ureteric bud, ultimately opens up to form part of the urogenital sinus. In this way the openings of the wolffian duct and of the ureter become separated (Fig. 12.6).

In the male, the wolffian duct persists as the vas deferens and epididymis, and is connected to the testis by the vasa efferentia and rete testis which are of mesonephric origin. The seminal vesicle is an outgrowth from the wolffian duct. In both sexes, the ureteric bud forms the ureter, the pelvis and calyces of the kidney and, by its contribution to the wall of the urogenital sinus, part of the base of the bladder and the urethra. But, in the female, the wolffian duct proper begins to degenerate at the eighth to the ninth week (33 mm C.R. embryo) and only remains in the adult as the rudimentary Gartner's duct (Figs 2.13 and 12.5). Portions of this are found in the meso-salpinx, beside the uterus, in the cervix, in the anterolateral vaginal wall and in the region of the clitoris and urethra.

## MÜLLERIAN DUCTS

The *müllerian (paramesonephric) ducts* appear between the fifth and sixth weeks (10 mm C.R. embryo), one in the outer part of each intermediate cell mass (Fig. 12.1). They

form as buds of coelomic epithelium at the cranial end of the urogenital ridge. Each one grows down lateral to the corresponding wolffian duct until it reaches a low level. There it turns inwards and, crossing anterior to the wolffian duct, joins its fellow from the opposite side at the back of the urogenital sinus (Fig. 12.4). The Sertoli cells secrete a glycoprotein known as anti-müllerian hormone (AMH), which causes regression of the paramesonephric (müllerian) duct system in the male embryo and is the likely signal for differentiation of Leydig cells from the surrounding mesenchyme. Testosterone is produced by the Leydig cells and, with the converting enzyme  $5\alpha$ -reductase, dihydrotestosterone. Testosterone is responsible for evolution of the mesonephric (wolffian) duct system into the vas deferens, epididymis, ejaculatory ducts, and seminal vesicle. Dihydrotestosterone results in development of the male external genitalia and the prostate and bulbourethral glands.

In the male, the action of a specific *müllerian inhibiting substance* liberated by the foetal testes causes the ducts to degenerate quickly, their only remnants in the adult being the *uterus masculinus*. In the female they persist, and their lower ends fuse to form the uterus while their separated upper parts with open ends become the fallopian tubes and the abdominal ostia. They also give off solid downgrowths to form the upper vagina.

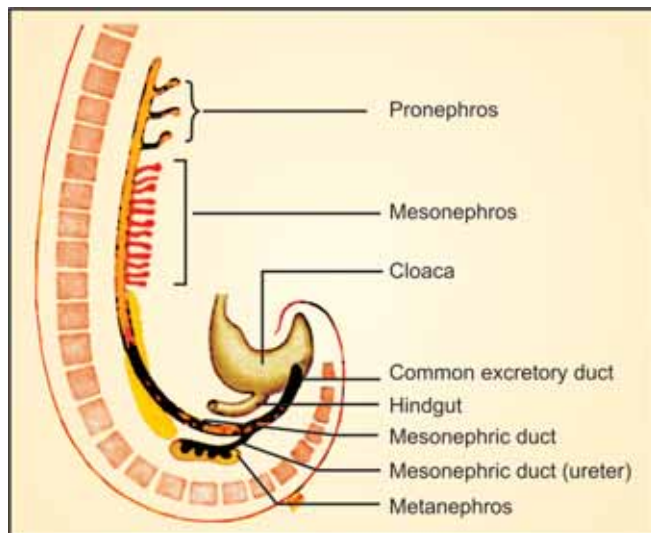


Fig. 12.4: Diagrammatic representation of a later stage in the development of the wolffian and müllerian ducts

In forming the uterus, the müllerian ducts fuse from below upwards, their adjacent walls breaking down to form a single cavity. Fusion begins at the seventh or eighth week (22 mm C.R. embryo) but is not complete until the twelfth week (55 mm C.R. embryo) of intrauterine life. The top of the uterus is at first flat, the domed fundus being a later postnatal development. Differentiation of the cervix from the body of the uterus is recognisable by the tenth week but the cervix is not clearly separated from the vagina until the twentieth week. Primitive endometrial glands are present by the sixteenth week and cervical glands by the twenty-eighth week. These later come under the influence of placental hormones so, at birth, they show evidence of some proliferation and even secretory activity which subsides during the early days of extrauterine life.

At birth the uterus measures approximately 35 mm in length and weighs 2 g. It is disproportionately large because of the stimulus it has received from the maternal oestrogen. Within 2 weeks it decreases in size by one-third so that its overall length is 23 or 24 mm, two-thirds of which is made up of cervix (Fig. 2.16). Throughout infancy and childhood there is only slight growth in proportion to physical development, and the uterus of a girl of 8 or 9 years of age is essentially similar to that of a newly born child. During the 2 years preceding the menarche, the uterus suddenly grows apace so that it

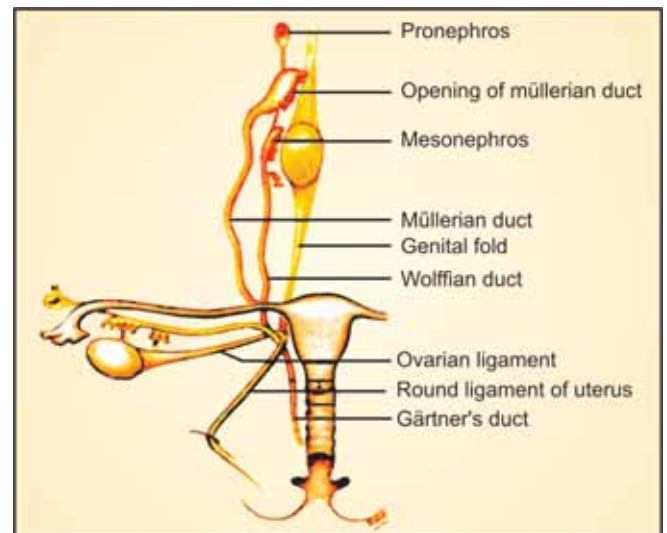
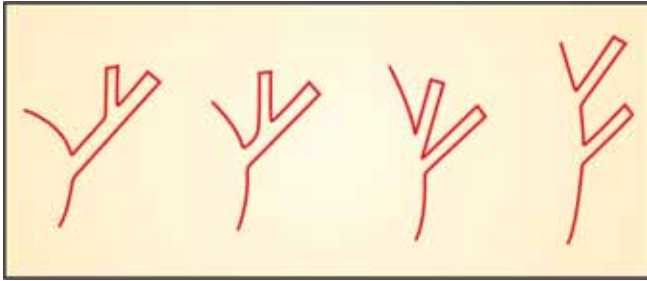


Fig. 12.5: The ultimate fate of the ducts and ligaments before and after descent of the ovary and its associated structures. H-hydatid of Morgagni; E-epoophoron; P-paroophoron

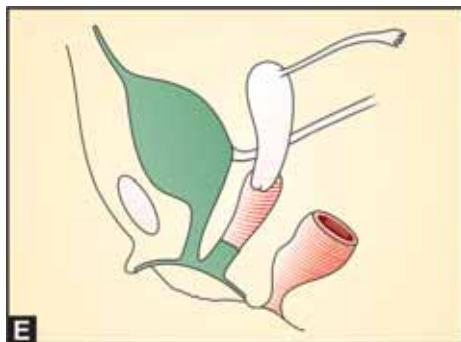
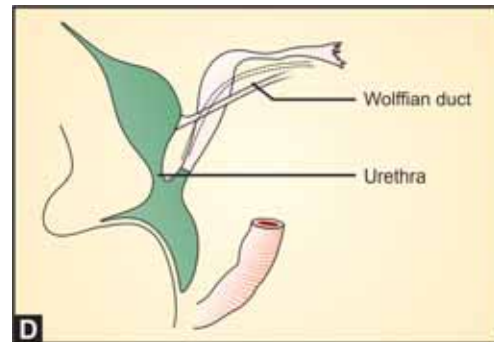
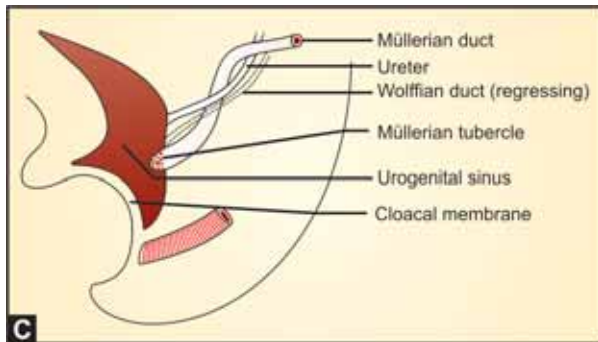
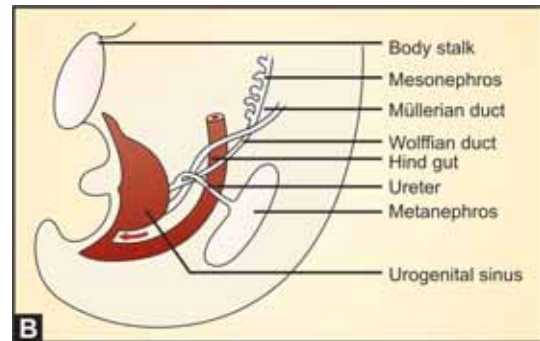
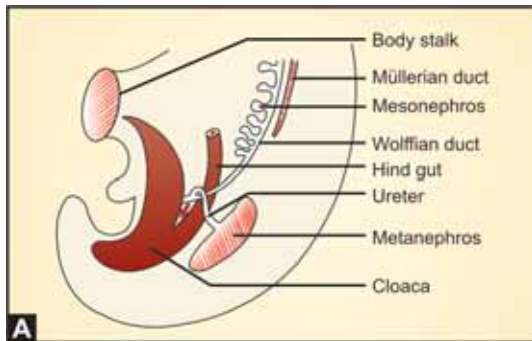


**Fig. 12.6:** The stages whereby the lower part of the mesonephric (wolffian) duct is opened out to form part of the wall of the urogenital sinus. By this process the duct and its ureteric bud come to have separate openings into the sinus

doubles in length and increases 10 times in weight to approach adult dimensions and shape. At this stage, however, it is not mature and is not fully capable of reproduction. Uterine maturity, a rather nebulous property, is only attained during the following 2 or 3 years. At birth and during childhood the uterus is almost devoid of flexion and version, characteristics which only develop around the time of puberty. It is upright in the pelvis or tilted slightly backwards towards the sacral promontory.

**MESENTERIES AND LIGAMENTS**

As the gonad and wolffian systems develop, they project into the coelom until ultimately they are attached to its



**Figs 12.7A to E:** Diagrammatic explanation of the partition of the cloaca and the development of the vagina, (A) The early situation, hindgut and cloaca developing from endoderm. The arrow indicates a mesodermal downgrowth. (B) The urogenital sinus is forming as the urorectal septum of mesoderm (arrowed) divides the cloaca and separates the hindgut. (C) The müllerian ducts impinge on the urogenital sinus and form the müllerian tubercle. The sinovaginal bulbs develop at this site. The ureter now opens separately into the urogenital sinus, (D) The urogenital sinus above the müllerian tubercle narrows to form the urethra. The lower vagina forms from the urogenital sinus, (E) The cloacal membrane breaks down to expose the opened-up lower part of the urogenital sinus which is the vulva. The posterior part of the cloacal membrane opens to form the anus. All tissues of urogenital sinus origin are shown in heavy black in (C), (D) and (E)

posterior wall by the *urogenital mesentery* (Figs 12.1 B, D); this is destined to become the broad ligament. The gonad then develops its own *genital mesentery* which is ultimately the mesovarium. The part of the urogenital mesentery lying outside or above the attachment of the genital mesentery contains the müllerian duct, wolffian (Gartner's) duct and the remains of the pronephros and the meso-nephros; it is thus recognisable as the mesosalpinx.

Below the gonad, the genital ridge is continued down the posterior coelomic wall and turns forwards to what will become the lower abdominal wall. It is called the *genital ligament* or *gubernaculum* and plays an important part in the ultimate descent of the gonad, especially in the male. In the female, the genital ligament is caught up by the müllerian ducts where they come together, and is thus divided into two parts. The lower part becomes the round ligament running from the cornu of the uterus to the abdominal wall. The upper part is the ovarian ligament attaching the ovary to the cornu of the uterus (Fig. 12.5).

As their foetal development proceeds, the unfused portions of the müllerian ducts and the adjacent gonads descend towards the pelvis; this accounts for the fallopian tubes' lying at right angles to the uterus and for the change in direction of the urogenital mesenteries to become the broad ligaments. The ovaries descend during the seventh to the ninth months and, at birth, are situated at the pelvic brim.

### DEVELOPMENT OF THE VAGINA, BLADDER AND URETHRA

The cloaca is the lower end of the included yolk sac (endoderm) and, at an early stage of development, is divided into the *hindgut* and *urogenital sinus* by a downgrowth of mesoderm which forms the *urorectal septum* and ultimately the perineal body (Fig. 12.7). The lower ends of the fused müllerian ducts lie in close association with the posterior part of the urogenital sinus, and give rise to a solid downgrowth of tissue which invaginates the urogenital sinus to produce a prominence called the *müllerian tubercle*. (Fig. 12.7). There is a proliferation of urogenital sinus tissue to form the bilateral *sinovaginal bulbs*, also solid structures. The upper three-quarters of the vagina, and sometimes most of the vagina, is formed from the müllerian downgrowths which become canalised.

The lower part of the vagina develops by canalisation of the sinovaginal bulbs, a process which is not complete until the twenty-first week. Incomplete breakdown of the junction between the bulbs and the urogenital sinus proper leaves the hymeneal membrane.

Although the vagina is mainly müllerian duct in origin, it is said that its epithelial lining represents an upgrowth of urogenital sinus tissue (which includes the bulbs) and that this explains why it is stratified in type. There are doubts about this explanation because clinical observations show that, when the lower half or more of the vagina fails to develop, its upper compartment is still lined by stratified squamous epithelium. A better explanation is metaplasia. The vaginal fornices are differentiated by the twentieth week.

The part of the urogenital sinus immediately above the müllerian tubercle becomes narrowed to produce the urethra; the part below opens out to become the vestibule of the vulva with the urethra and vagina opening into it (Fig. 12.7D).

The bladder itself is the upper part of the uro-genital sinus and at first has a diverticulum (*allantois*) into the body stalk. This later retrogresses, its remains being the urachus running from the fundus of the bladder to the umbilicus.

### DEVELOPMENT OF THE VULVA

The external genitalia develop in the area bounded in front and above by the body stalk, and below and behind by the tail of the embryo (Fig. 12.8). It is not easy to recognise the sex of the external genitalia until the eleventh or twelfth week (50 mm C.R. embryo). By the fourth or fifth week, the *genital tubercle* is formed in front

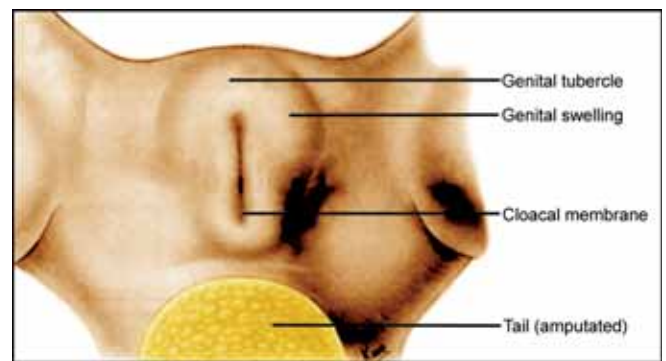
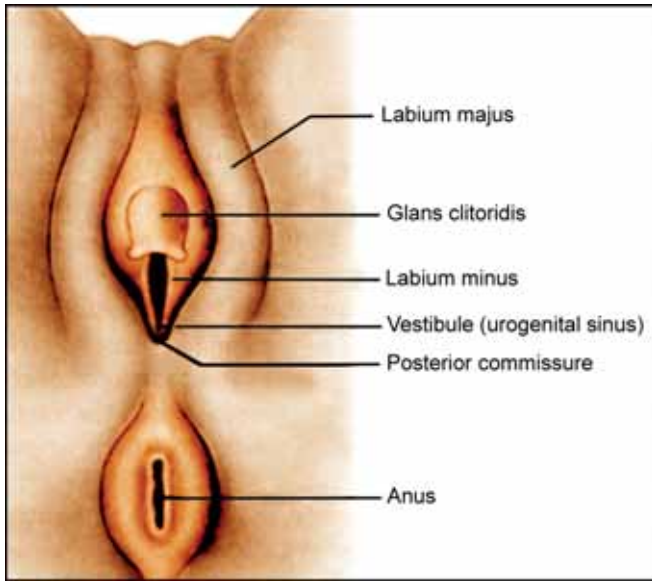


Fig. 12.8: The sexually undifferentiated genitalia of the 4-5-week-old (10 mm) embryo



**Fig. 12.9:** The external genitalia of the 10-12-week-old female embryo. The cloacal membrane has broken down to expose the urogenital sinus (vestibule)

by the fusion of two mesodermal thickenings. From this the *genital swellings* sweep backwards one on either side towards the tail; between them is the *cloacal membrane*

which is two-layered, ectoderm without and endoderm within. The urorectal septum of mesoderm, which grows down to separate the urogenital sinus from the hindgut, divides this membrane into urogenital and anal parts, and forms the perineal body.

The genital tubercle ultimately becomes the *phallus* (the penis in the male and the clitoris in the female); the genital swellings develop into the scrotum in the male and the labia majora in the female.

The urogenital membrane breaks down in its centre at the sixth week to expose the lower parts of the urogenital sinus which are destined to become the vestibule, urethra and lower vagina (Figs 12.7 and 12.9). Meanwhile, genital folds appear medial to the genital swellings, passing backwards from the genital tubercle, one on each side. In the male, and commencing at the tenth week, these fuse in the midline to form the floor of the penile urethra. In the female they remain separate as the labia minora.

Bartholin's glands and Skene's tubules are developed from outgrowths of the urogenital sinus, the former being homologous to Cowper's (bulbo-urethral) glands, and the latter to the prostate, in the male. The female urethra is homologous to the upper part of the prostatic portion of the male urethra.

# CHAPTER 13

## Malformations and Maldevelopments of the Genital Tract

Müllerian Duct Anomalies	196	Vulva	214
Ovary	209	Errors Arising in Connection	
Fallopian Tube	209	with the Cloaca	216
Uterus	209	Malformations of the Urinary Tract	217
Vagina	211		

It is important to understand the connection between the urogenital system in development. The female urinary and genital tracts are closely related, not only anatomically but also embryologically. About 10 per cent of infants are born with some abnormality of the genitourinary system, and anomalies in one system are often mirrored by anomalies in another system. The early development of the genital system is similar in both sexes and the ambiguous sex is seen usually if it is connected to chromosomal abnormalities and are called as intersex conditions or hermaphroditism.

Three main principles govern the practical approach to malformations of the genital tract.

1. The müllerian and wolffian ducts are so closely linked embryologically that gross malformations of the uterus and vagina are commonly associated with congenital anomalies of the kidney and ureter.
2. The development of the gonad is separate from that of the ducts. Normal and functional ovaries are therefore usually present when the vagina, uterus and fallopian tubes are absent or malformed.
3. Gross malformations such as absence of the uterus and vagina may be associated with anomalies in the sex chromosome make-up of the individual (*see* Chapter 14). There is also some evidence that less severe malformations, such as bicornuate uterus, can be genetically determined, the taint being passed from mother to daughter.

### MÜLLERIAN DUCT ANOMALIES

The classification of müllerian duct anomalies is shown in Table 13.1.

#### Absence or Incomplete Development of Both Müllerian Ducts (Class I)

##### *Pathology*

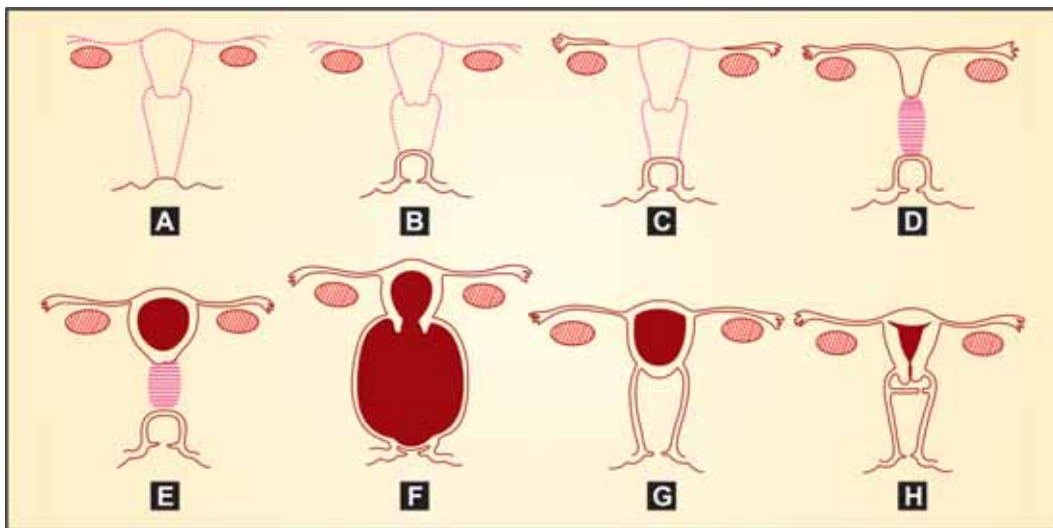
Complete failure in development of the müllerian ducts results in absence of the fallopian tubes, uterus and most of the vagina (Mayer-Rokitansky-Küster-Hauser

**Table 13.1: American Society for Reproductive Medicine Classification of Müllerian Anomalies (1988)**

Classification	Anomaly
Class I (Agenesis/Hypoplasia)	a. Vaginal b. Cervical c. Fundal d. Tubal e. Combined
Class II (Unicornuate)	a. Communicating b. Non-communicating c. No cavity d. No horn
Class III (Didelphys)	Didelphys
Class IV (Bicornuate)	a. Complete b. Partial
Class V (Septate)	a. Complete b. Partial
Class VI (Arcuate)	Arcuate
Class VII (DES-related)	DES-related

Reprinted by permission from the American Society for Reproductive Medicine (*Fertility and Sterility* 1988; Vol. 49 (6): pages 944-945)

[MRKH] syndrome). In such cases the vulva is likely to be normal and there may be a depression of variable depth representing the lower (urogenital sinus) part of the vagina. It is usual to find such a depression covered with a normal hymen (Figs 13.1, 13.3 and 13.12). The patients have a normal female karyotype. Renal ectopy and agenesis, skeletal abnormalities, as well as cardiac anomalies are associated. A multifactorial mode of inheritance has been postulated. The MRKH syndrome has been linked with decreased galactose-1-phosphate uridyl transferase activity leading to increased intrauterine galactose exposure. An association with the major histocompatibility antigen has also been reported. Poorly formed ducts of full length result in hypoplasia of the whole genital tract. Incomplete development sometimes affects the lower parts of the ducts only. Thus, well-formed abdominal ostia may be associated with hypoplasia or absence of the remainder of the tubes, of the uterus and of the vagina (Fig. 13.1). Or again, the tubes and uterus may be present and the vagina absent, rudimentary or imperforate. The converse is not usually



**Fig. 13.1:** Examples of malformations resulting from absence, hypoplasia or atresia of both müllerian ducts. The ovaries are usually present and functional as shown in each of the figures. (A) Complete absence of all the müllerian derivatives and also of the urogenital sinus component of the vagina. (B) As (A) but the urogenital sinus part of the vagina, with the hymen below, is normally formed; this is more common than (A). (C) Only the proximal parts of the müllerian ducts are developed so only the fimbrial extremities of the tubes are present. (D) Failure of the distal parts of the müllerian ducts to develop or to canalize. A hypoplastic uterus is therefore present but the vagina is absent. (E) As (D) but the uterus is well enough developed to menstruate with a resulting haematometra. In practice, whenever there is a functional uterus there is usually a small compartment of the upper vagina present as well (see text and Fig. 13.12). (F) Imperforate vagina with haematocolpos and haematometra. The hymen is normal and is situated below the obstructing membrane. (G) Congenital atresia of the cervix with haematometra; in this condition the vagina below is usually normal as shown here. (H) A congenital incomplete membrane or stricture in the upper vagina - 'phimosis of the cervix'

true because the ducts grow downwards; so a well-formed uterus is rarely associated with absence of the fallopian tubes.

### Clinical Aspects

Patients usually present between 15 and 18 years of age with primary amenorrhoea. Growth and secondary sexual characteristics are normal.

Although findings on local examination are usually as described above, some patients may have a small vaginal pouch developed as a result of repeated attempts at intercourse. On rectoabdominal examination, the uterus cannot be palpated.

Ultrasound confirms the absence of the uterus and demonstrates the ovaries. Occasionally, the rudimentary uterine horns can be seen. If ultrasound is inconclusive, MRI or laparoscopy is required. MRI is the ideal method for demonstrating uterine malformations.

Chromosomal analysis is not usually required in these patients; however, some patients who present before puberty may require a karyotype to distinguish the condition from one of the forms of male pseudohermaphroditism.

Renal anomalies are the commonest associated features seen in 40 per cent of cases, ranging from complete agenesis to malposition (usually a pelvic kidney), to subtle architectural alterations. Skeletal

abnormalities can involve the spine, limbs or ribs. These are seen in 10-15 per cent of patients. Some patients have subclinical auditory defects.

Treatment is primarily by vaginoplasty and is discussed on pages 209-210.

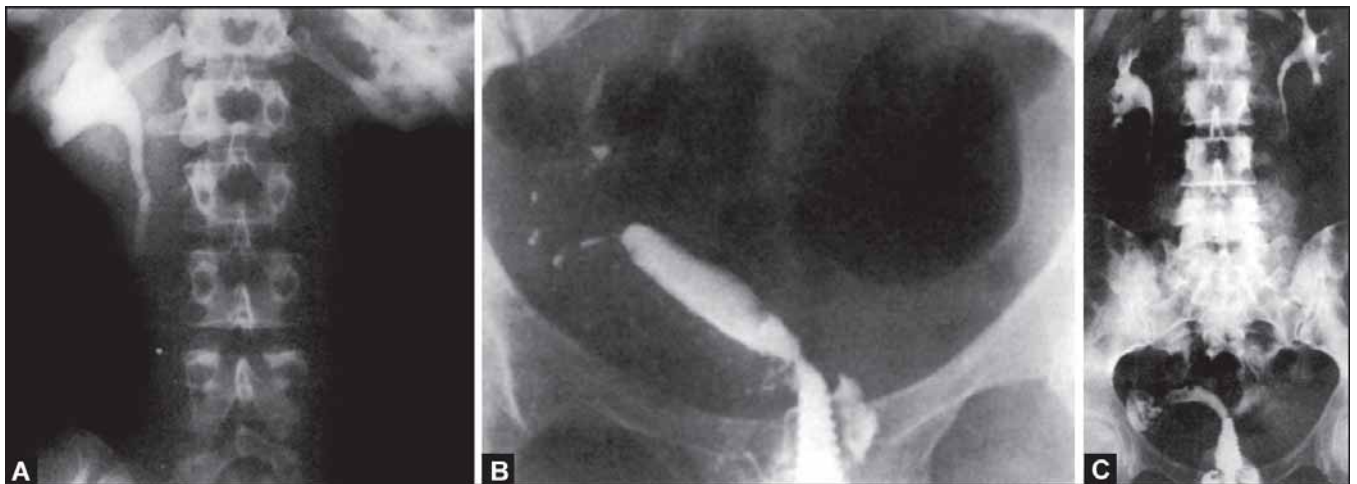
The clinical aspects are discussed under malformations of the tubes, uterus and vagina.

### Absence or Incomplete Development of One Müllerian Duct (Class II)

#### Pathology

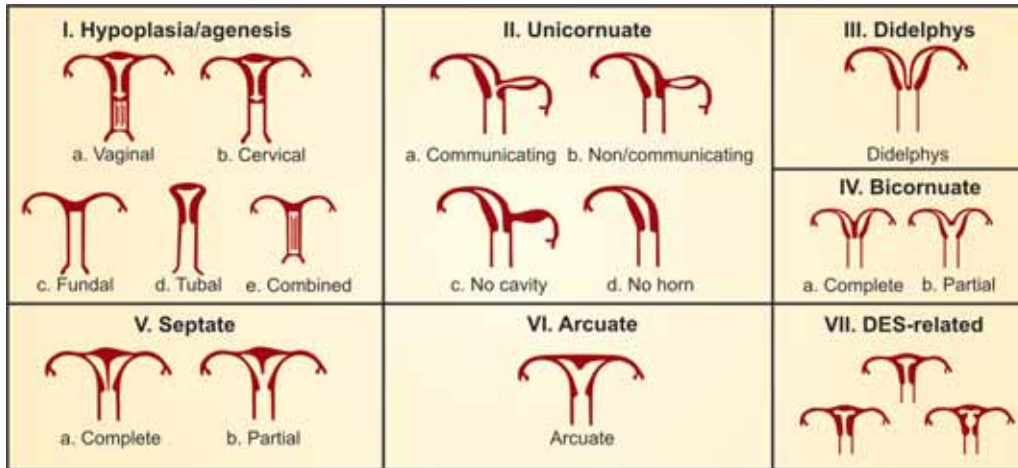
Absence of one müllerian duct results in a *unicornuate uterus* with only one fallopian tube (Class II). The cervix and vagina may be normal in appearance and function but they represent strictly only one half of the fully developed organs. A true unicornuate uterus is rare and is usually associated with absence or gross malformation of the renal tract on the side of the missing müllerian duct (Figs 13.2 and 13.3).

Incomplete development of one müllerian duct gives rise to the more common *apparent* unicornuate malformation; this is distinguished by the finding of a fallopian tube and round ligament, rudimentary though they may be, on the affected side. In this condition two kidneys are usually present, although occasionally, the one on the affected side may also be hypoplastic and not show on intravenous pyelography (Figs 13.2A and B).



**Figs 13.2A to C:** (A) and (B) Hysterosalpingogram and intravenous pyelogram in the same woman, illustrating congenital absence of the left müllerian duct and wolffian system. A true unicornuate uterus is thus associated with absence of the kidney on the opposite side, (C) A hysterosalpingogram showing an apparent right-sided unicornuate uterus; but the presence of kidneys, indicated by the pyelogram on the same woman, proves that the uterus must be bicornuate with a hypoplastic horn on the left side not communicating with the cavity of the uterus. This was proved at laparotomy





**Fig. 13.3:** The American Society for Reproductive Medicine classification of müllerian anomalies. Reprinted by permission from the American Society for Reproductive Medicine (*Fertility and Sterility* 1988; Vol. 49 (6): pages 944-945)

### Symptoms

A unicornuate uterus causes few symptoms and is usually only discovered by chance or as a result of pregnancy complications. If it happens that the patient has dysmenorrhoea, the pain is limited to the side on which the horn is present. The condition does not, as a rule, lower fertility significantly but it favours abortion and premature labour, breech presentation of the foetus and fundal insertion of the placenta. The uterus usually contracts efficiently in all stages of labour.

### Diagnostic Signs

The uterus which leans well to one side of the pelvis and which cannot easily be straightened should always be suspected as being unicornuate but the diagnosis can only be made for certain by inspection of the pelvic organs. Hysterosalpingographs are helpful but do not always distinguish between true and apparent unicornuate deformity (Figs 13.2 and 13.3).

### Treatment

No treatment is indicated for the *true* unicornuate uterus. The rudimentary horn of an *apparent* unicornuate uterus may have to be excised if it causes symptoms (*see below*).

### Imperfect Fusion of the Müllerian Ducts

#### Pathology

Failure of fusion of the müllerian ducts occurs in varying degrees (Fig. 13.3). If minor degrees involving uterine

shape are included, this type of malformation is extremely common and can be demonstrated in 10-15 per cent of fertile women. The different nomenclatures and classifications of the resulting deformities are confusing. Sometimes the external and internal shapes of the uterus are both affected, sometimes only one. From the standpoint of obstetrical complications the shape of the cavity is the more important.

#### Uterus didelphys (Class III)

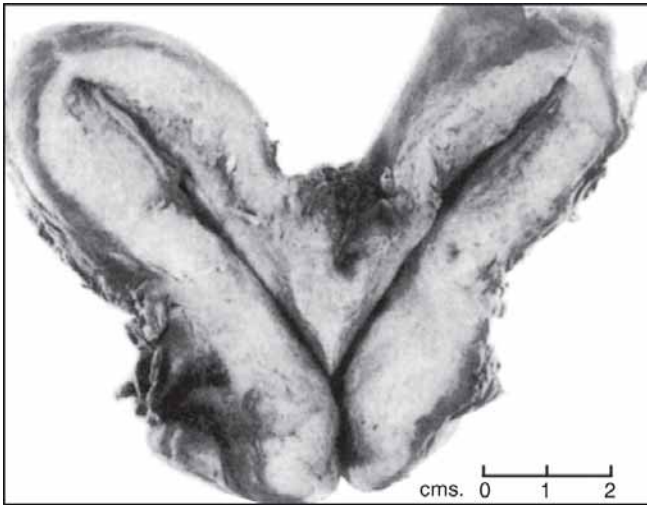
If the two müllerian ducts remain separate, the two halves of the uterus remain distinct and each has its own cervix (Figs 13.3, 13.5 and 13.7). Some distinguish between *uterus didelphys* and *uterus pseudodidelphys* according to the degree of separation of the two ducts and they believe that even the vulva should be duplicated in a true didelphys uterus. However, this view is not widely held. Occasionally, and especially if they are rudimentary, the horns are very widely separated and rarely may be found in the sacs of inguinal hernias.

#### Bicornuate Uterus (Class IV)

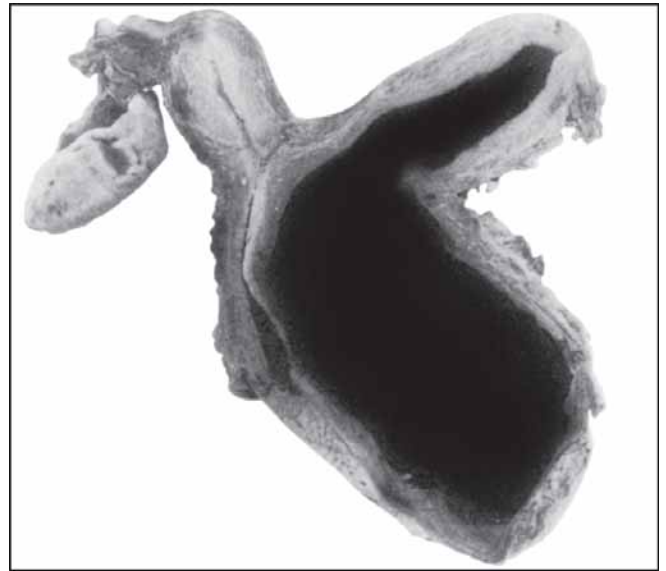
In this condition only the lower parts of the ducts fuse, leaving the cornua separate (Figs 13.3, 13.4, 13.6 and 13.7). The cervix and vagina may be single or double.

#### Septate and Subseptate Uterus (Class V)

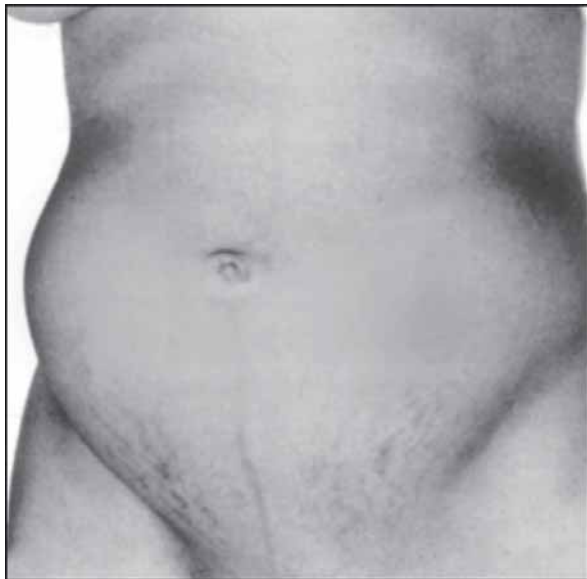
The uterus is outwardly normal but contains a complete or incomplete septum which reflects a failure in



**Fig. 13.4:** Uterus bicornis unicollis. Both horns are equally and well developed; the resulting increased bleeding surface explains why the patient concerned always had very heavy periods which ultimately necessitated hysterectomy



**Fig. 13.5:** Uterus didelphys with one half of a septate vagina imperforate. This has resulted in a unilateral haematocolpos and haematometra, the diagnosis of which in life might have been missed because the patient concerned menstruated normally from the other side



**Fig. 13.6:** A bicornuate uterus containing a pregnancy of 32 weeks' duration. The broad-topped uterus with a depression between the horns is clearly visible. This condition may cause a transverse lie but, in this case, the patient delivered normally at term

breakdown of the walls between the two ducts (Figs 13.3 and 13.7D). The cervical canal may be single or double, and the vagina whole or septate.

#### *Septate and Subseptate Vagina*

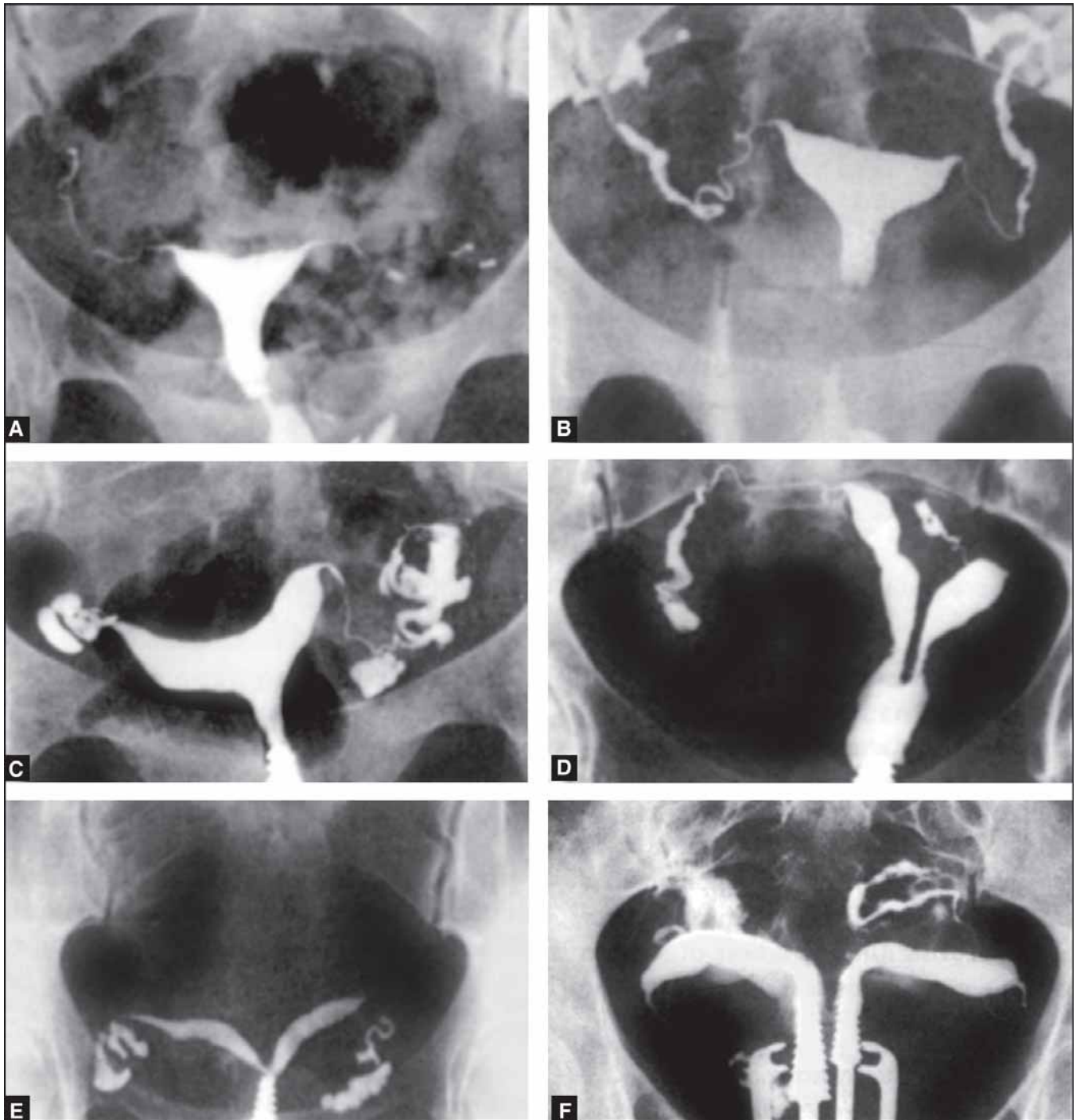
A sagittal septum with a crescentic lower edge may be present in the upper vagina or throughout its length (Fig. 13.8). It can occur alone or in conjunction with a septate or bicornuate condition of the uterus, and may have one or two cervixes opening into it. This condition arises either because late fusion of the müllerian ducts gives rise to two müllerian tubercles, or because of failure of proper canalisation of the two sinovaginal bulbs. Very rarely, the septum is disposed from side to side and this is supposed to be explained by rotation of the müllerian ducts on each other.

#### *Arcuate Uterus (Class VI)*

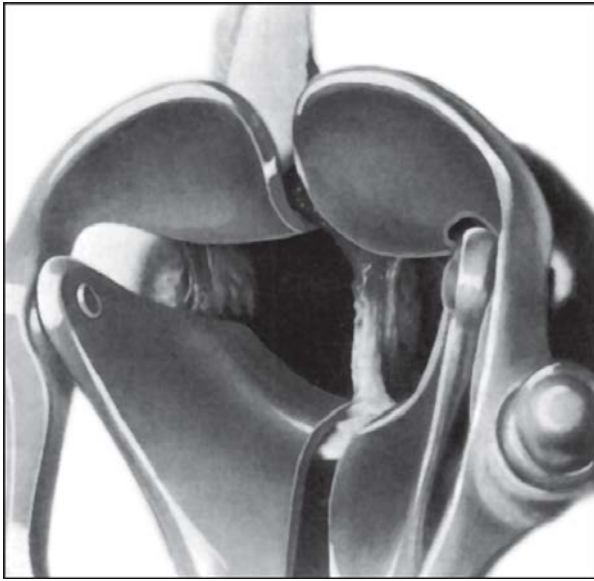
This is a flat-topped uterus in which the fundal bulge has not developed after fusion of the ducts (Figs 13.3 and 13.7A and B). If only the exterior of the uterus is affected, the fundal myometrium is abnormally thin.

#### *Deformities in Combination (Figs 13.3 and 13.5)*

The above deformities occur in all manner of combinations. Moreover, they may be associated with atresia or underdevelopment of one or both müllerian ducts.



**Figs 13.7A to F:** Certain types of müllerian duct malformation deformity revealed by hysterosalpingography. (A), (B) Degrees of arcuate deformity, (C) A minor degree of bicornuate malformation; this type of radiograph is difficult to interpret because a similar picture can be produced by a fundal leiomyoma. (D) Septate uterus, (E) Uterus bicornis unicollis, (F) Uterus didelphys with a cannula in each cervix



**Fig. 13.8:** Septate vagina, the septum being displayed by a four-bladed speculum. The patient concerned also had a uterus didelphys with a cervix opening on either side of the septum. She was an unmarried woman, aged 31 years, who was admitted to hospital suffering from haemorrhage from the lower border of the septum and was so exsanguinated as to require blood transfusion. The alleged cause of the haemorrhage was an attempt to insert a menstrual vaginal tampon for the first time; it may, however, have been an attempt at coitus

For example, one half of a uterus didelphys may communicate with the vagina and the other may not. Or again, one or both horns of a bicornuate uterus may be rudimentary.

#### *DES-related Anomalies (Class VII)*

Several characteristic anomalies have been described in women who were exposed to diethylstilboestrol (DES) *in utero*. Benign vaginal adenosis and cervical hoods, septae, collars and cockscombs are seen in a large number of cases. T-shaped uteri, wide lower segments and constriction bands have also been described. There is a high incidence of perifimbrial paratubal cysts. Vaginal clear cell adenocarcinoma is very rare. Unlike all other congenital uterine malformations, the DES uterus is not associated with an increase in renal anomalies.

#### **Cause**

The müllerian ducts are ordinarily pulled together by subperitoneal fibromuscular tissue and it is suggested

that a defect in this process is a cause of these malformations. The uterus didelphys and bicornuate uterus often have unusually thick and strong round ligaments, and a tough *vesicorectal fold* running between each horn; it may be that these prevent the müllerian ducts coming together.

#### **Symptoms**

These abnormalities are relatively common but they pass unnoticed because they are often symptomless. *The majority are first recognised during pregnancy, or as a result of a pregnancy mishap; this only goes to show that, excepting the condition of septate vagina, they do not as a rule lower fertility materially.*

#### **Menstrual**

The menstrual cycle is usually normal.

#### *Menorrhagia*

Menorrhagia can occur because of the larger bleeding surface offered by two well-developed uterine horns (Fig. 13.4).

#### *Spasmodic Dysmenorrhoea*

This is presumably explained by the unusual arrangement of the musculature and by abnormal contractions. Unequal development of the two horns can be manifested by *one-sided* dysmenorrhoea.

#### *Failure to Contain Flow*

Failure to control the menstrual outflow by means of a single intravaginal tampon can give a clear lead to the diagnosis of a septate vagina and uterus didelphys.

#### **Coital**

#### *Dyspareunia*

A vaginal septum may cause difficulty in coitus but this is often overcome without the couple realising the abnormality. One half of the vagina is then usually dilated and the septum is pushed to the side.

#### *Bleeding*

Attempts at coitus or at the insertion of a tampon sometimes cause bleeding from a vessel in the lower edge of the septum (Fig. 13.8).

### Obstetrical

#### *Infertility*

The only form of malformation deformity which may lower fertility significantly is a fully septate vagina. In such circumstances, coitus may take place in the half which does not communicate with the cervix or with the better developed cervix and uterus. Even if coitus is practised sometimes on one side and sometimes on the other side of the septum, there is always a 50 per cent chance that semen is deposited in the müllerian duct which does not serve the ovary which has ovulated in that particular cycle.

#### *Cornual Pregnancy*

See page 156.

#### *Site of the Conceptus*

In successive pregnancies, this is not necessarily the same cavity of the 'double' uterus. If both horns are well developed, either may be used. When twinning occurs the foetuses sometimes have a horn each.

#### *Sacculation of the Uterus*

This presents as either an organic or a functional abnormality during pregnancy. When the sacculum is sited on the line of junction of the müllerian ducts it may be a manifestation of a fusion defect.

#### *Abortion and Premature Labour*

These are common when the uterus is malformed because of abnormal contractions; inadequate stretching and hypertrophy to accommodate the pregnancy; poor implantation; or placentation on a septum. Uterine malformation tends to cause late, rather than early abortion, because of an associated incompetent os.

#### *Malpresentation*

Malpresentation of the foetus, and the related fundal or cornual insertion of the placenta, are often explained by an abnormality in shape of the uterus. A subseptate or bicornuate deformity favours a transverse lie; a uterus didelphys or a unicornuate uterus favours a breech presentation. The finding of a transverse lie which resists version, or a history of malpresentation in several pregnancies, should always raise a suspicion of uterine malformation.

#### *Inefficient Uterine Action*

This is not often seen in the first and second stages of labour but is common in the third. Manual removal of the placenta may be necessary in cases of bicornuate, septate and subseptate uterus and the incidence of postpartum haemorrhage is increased. If the horns are completely separate, however, expulsive action is generally good. A high vaginal septum can prevent the cervix from dilating.

#### *Obstructed Labour*

The non-pregnant horn of a uterus didelphys enlarges during pregnancy, being subjected to the same hormone influences as the pregnant horn. Sometimes it remains low in the pelvis and then constitutes a tumour which obstructs the delivery of the foetus. Labour may also be obstructed by a vaginal septum, a classical situation arising when the breech presents astride the septum.

### Diagnostic Signs

A septate vagina and two cervixes *may* be obvious on vaginal examination and either finding should immediately raise the possibility of a fusion defect in the uterus. On bimanual examination it may be possible to feel the two separate uterine horns or a depression in the fundus; failing that, a very suggestive sign is an impression *that the uterus is unusually wide from side to side*. A septate uterus cannot be diagnosed on bimanual examination but may be recognised by passing a sound, as may the more extreme malformations. Apart from laparotomy or laparoscopy (which may fail to reveal a septate uterus), the diagnosis of uterine malformation defects is best made by hysteroscopy or hysterosalpingography (Fig. 13.7). MRI is an excellent modality for accurate diagnosis, but is more expensive and not universally available.

The clinical diagnosis of septate vagina and of uterus didelphys can be extraordinarily elusive, particularly if there is unequal development of the two sides and if a septum is displaced. I recall several cases in which experts overlooked the existence of a second vagina and uterus in patients examined under anaesthesia. This resulted in dilatation of only one cervix in cases of dysmenorrhoea - without relief of the pain; delay in the diagnosis of two cases of carcinoma of the body of the uterus - only the healthy horns being curetted; local treatment of vaginitis in only one half of the vagina;

insertion of an IUCD into one horn; insertion of a dye for hysterosalpingography into only one horn with a subsequent erroneous diagnosis of unicornuate uterus; evacuation of the non-pregnant horn during therapeutic abortion; and caesarean section in two successive pregnancies for failure of the non-pregnant cervix to dilate. The overlooking of duplication due to ductal malfusion can also cause problems with intravaginal and intrauterine contraceptive devices (IUCDs).

During pregnancy, a diagnosis of uterus bicornis or didelphys is made by feeling the non-pregnant horn lying to one side and a little in front of or behind the main tumour. It is frequently mistaken for a subserous leiomyoma or ovarian cyst. This error can usually be avoided by careful palpation, which reveals varying shape and consistency due to intermittent contractions in the case of the uterine horn. The shape of the pregnant horn and the lie of the foetus may also be guides (Fig. 13.6).

Whenever a placenta has to be removed manually, or curettage carried out to complete an abortion, the cavity of the uterus should carefully be explored by hand, finger, sound or curette to exclude a septum or bicornuate deformity.

### Treatment

The treatment of malfusion deformities of the müllerian ducts depends on the exact state of affairs present and on the symptoms produced. Each case requires separate consideration. Many are best left untreated. Vaginal septa are generally removed unless they are symptomless and there is no prospect of marriage and childbearing. Rudimentary uterine horns, especially those not communicating with the main cavity, often require excision.

When a bicornuate or septate uterus has caused not less than three miscarriages and no pregnancy has resulted in a viable child, surgery may be indicated. Prior to surgery a thorough work-up is mandatory to exclude all other causes of recurrent abortion. In the case of bicornuate uterus, an incision is made over the uterus and the two horns are sutured together to form a single cavity (Fig. 13.9). The results depend on a careful choice of cases according to the exact anatomy as shown by hystero-graphy. The management of pregnancy and labour after this type of operation is important. Contrary to what is sometimes said, my experience indicates that

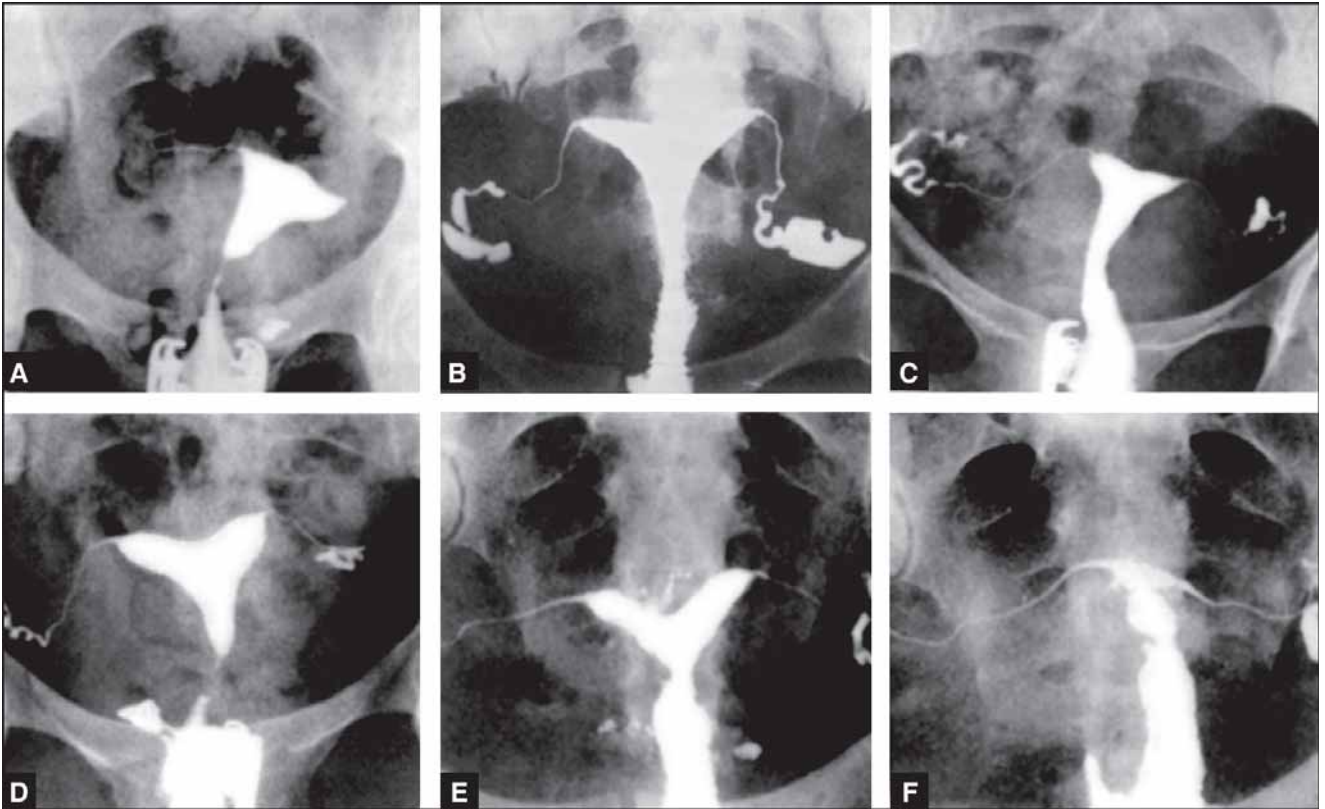
these scars heal well and withstand the stress of subsequent pregnancy and labour. Close monitoring is required. Caesarean section is reserved for obstetric indications; intraoperatively the scar of the previous repair can hardly be seen. However, induction of labour requires careful assessment of the case and even more careful monitoring. In such cases, there is a place for elective caesarean section. Undoubtedly there are many who would prefer to do an elective caesarean section at 38 weeks' gestation in all cases.

In the case of a septate uterus, the operation has been remarkably simplified with the advent of operative hysteroscopy. The older methods involved excision (Jones) or incision (Tompkins) of the uterine septum, followed by unification of the horns. These have now been replaced by a simple procedure wherein the septum is cut hysteroscopically by scissors, resectoscope or laser (argon, KTP or Nd-YAG) after inducing endometrial atrophy by administering a GnRH analogue for two months. The septum is relatively avascular but bleeding may occur when normal myometrium is reached. The resectoscope is therefore the most preferred method as it simultaneously coagulates the bleeders. Laser does not offer any special benefit. Laparoscopic guidance is required to confirm that the uterus is indeed septate and not bicornuate, and to determine the end-point of resection - the myometrial fibres can be seen hysteroscopically and the light can be seen transmitted through the fundus uniformly. If the diagnosis has been firmly established beforehand and the surgeon is experienced, laparoscopic control may not be required.

The main complications of hysteroscopic procedures are uterine perforation and fluid overload. Healing of the septal areas occurs in two months and they are covered by endometrium. Prophylaxis against intrauterine adhesion formation by the use of oestrogens, intrauterine Foley balloon catheters or IUCDs is not required. These patients do not face any additional risk in subsequent labours.

### Duplication and Diverticula of Müllerian Ducts

If the müllerian ducts are duplicated, a true double uterus with four fallopian tubes can result but this is a condition of extreme rarity. More common are diverticula of the ducts which give rise to: accessory abdominal ostia of the tube; accessory tubes; diverticula of the tube; or a uterine diverticulum or accessory horn. In the last



**Figs 13.9A to F:** Hysterograms illustrating uterine causes of abortion, (A) A normal uterus for comparison with the other hysterograms. Note the well-shaped fundus and the constriction at the level of the isthmus and internal os. (B) A normal fundus but a defective internal os ('funnel cervix') in a woman who had had repeated abortions and premature labours, (C) A funnel cervix and a minor degree of bicornuate deformity in the uterus of a woman who had had a series of premature labours, (D) A competent cervix but a bicornuate malformation in a woman who had had one abortion and one premature labour, (E) A bicornuate uterus in a patient with a history of four successive pregnancies ending in mid-trimester abortion or premature labour and stillbirth, (F) The same case as (e) after metroplasty. After this radiograph was obtained the woman conceived again and the pregnancy progressed well until the thirty-seventh week when bleeding from a placenta praevia prompted caesarean section; a live healthy baby resulted

condition, which is sometimes called a *mülleroma*, and is very rare, the third horn is not supplied with a fallopian tube or round ligament. If functional it can cause severe dysmenorrhoea.

### Incomplete Canalisation of Müllerian Ducts-congenital Gynatresia

The müllerian buds have solid tips behind which canalisation takes place progressively. The müllerian and sinovaginal bulb tissues which form the vagina are also lumenless at first. Failure to canalise results in either solid organs or membranes of varying thickness obstructing the genital canal. Thus a rudimentary uterus sometimes lacks a cavity and the vagina may be represented by an uncanalised column of tissue. Atresia may affect only

one müllerian duct so that one horn of a bicornuate uterus may fail to communicate with the cervical canal, or one half of a septate vagina may be a closed cavity (Fig. 13.5). Unilateral haematocolpos, mucocolpos and pyocolpos are not common. They can give rise to difficulty in diagnosis because the retained secretions create a tumour lying beside an apparently anatomically and functionally normal genital tract.

### Sites

#### Cervical Atresia

Congenital atresia of the cervix of an otherwise normal uterus or of a bicornuate uterus is rare. When it does occur, a reasonably normal vagina is invariably present. It is more common to encounter *apparent* cervical atresia

in association with absence of the lower vagina (Fig. 13.12).

### Vaginal Atresia

This occurs in various degrees and forms. The whole vagina may be represented by a solid strand of tissue which is difficult if not impossible to recognise. Whether or not this is present the condition is labelled *congenital absence of the vagina*. Next, the upper (46%), middle (40%) or lower (14%) zones of the vagina may be imperforate over an area 0.5-6.0 cm in depth. More frequently, the vagina is obstructed by a thinner membrane situated low in the vagina, just above the hymen. It represents a failure in breakdown of the partition between the müllerian and sinovaginal bulb contributions to the vagina. This condition of *imperforate vagina* is frequently misdiagnosed as the much less common *imperforate hymen*. However, the distinction between the two is largely academic because their effects and treatments are identical.

An obstructing membrane situated across the upper vagina, just below the cervix, may be complete but usually has a laterally placed tiny opening through which menstrual discharge escapes. This state of affairs which, on examination, gives the impression of a vaginal vault without a cervix, is sometimes called *phimosis of the cervix* (Fig. 13.1H). A minor degree of this deformity, amounting to no more than an annular constriction of the upper vagina, is more common.

### Pathology

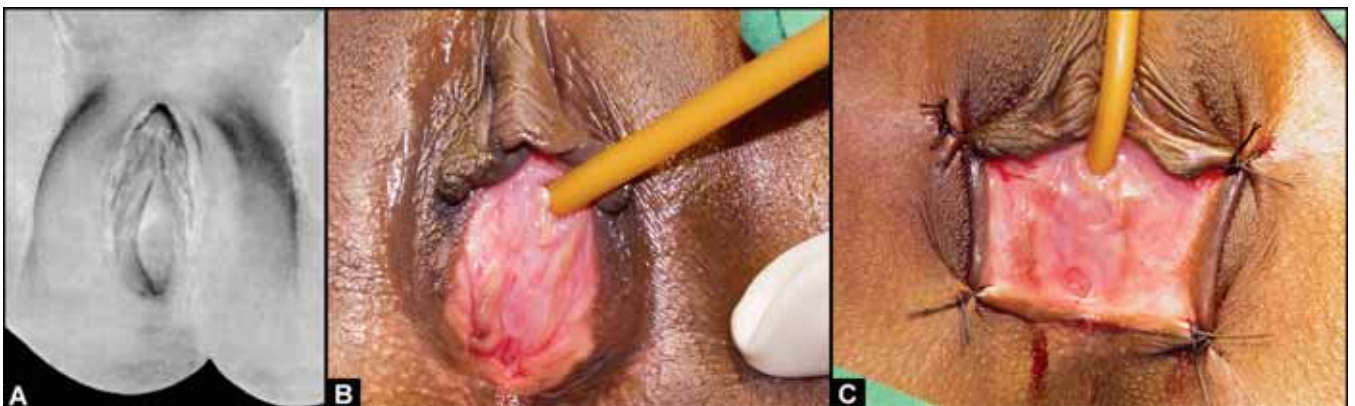
Atresia of the lower genital tract has no serious ill effects if the uterus is absent or functionless. If the uterus is

present, it is unusual to see any harm arise in childhood although a collection of mucus, sometimes bloodstained, in the uterus or upper vagina (*mucocolpos*) is possible. This may even be present at or soon after birth, the secretions of the uterus and cervix having been stimulated by placental hormones (Figs 13.10A to C).

When the uterus begins to menstruate, the fact is not recognised because the blood remains hidden behind the obstruction, a condition of *cryptomenorrhoea*. With each monthly discharge the vagina fills with blood which remains fluid. Some of its water content is continually being absorbed, so the material becomes inspissated. Nevertheless, the amount gradually increases and in the course of months or years distends first the vagina (*haematocolpos*), then the cervix and uterus (*haematocervix* and *haematometra*), and finally the tube (*haematosalpinx*). The altered blood tends to set up an aseptic inflammation in the tubes and this closes their outer ends and prevents or limits spill into the peritoneal cavity. If the tubes remain open, pelvic endometriosis is a possible complication. A mucocolpos or a haematocolpos can become infected to cause a *pyocolpos*.

Atresia of the cervix has similar results but only the uterus and tubes are affected.

The vagina can accommodate a large quantity of blood and, as it distends, forms a tumour which fills the pelvis and extends into the lower abdomen. The pelvic tumour displaces the fundus of the bladder upwards but not the urethrovesical junction. It causes retention of urine, not by elongating and attenuating the urethra, as is so often stated, but by interfering with the opening of the internal urethral sphincter.



**Figs 13.10A to C:** A mucocolpos in a newborn baby with the imperforate lower vaginal membrane bulging. This was incised when the baby was 3 days and 500 ml of mucoïd fluid escaped. (By permission of Mr H.H. Francis)



### Clinical Features

An incomplete vaginal membrane may cause dyspareunia, infertility or obstructed labour. Complete atresia only occasionally causes symptoms before puberty. The secondary sex characters then develop as usual but menstruation does not appear. Primary amenorrhoea, therefore, is often the complaint which brings gynatresia to light.

In the case of an imperforate lower vagina or hymen, the amenorrhoea may not at first be regarded as significant by the girl or her mother, and the symptom which sometimes prompts them to take advice is *acute retention of urine*. This occurs 3 or 4 years after the onset of hidden menstruation and the patient is therefore generally aged 15-18 years. Retention can be preceded by a phase of bladder irritability.

Often there is a history of monthly attacks of lower abdominal pain or backache with menstrual molimina. Pelvic discomfort and rectal pain are also noticed by some patients.

On examination, a tumour, dull to percussion, is found in the lower abdomen. This is caused partly by an overfull bladder with hypertrophied walls. When a catheter has been passed, however, a tumour may still extend to the level of the umbilicus or higher and this consists of the distended vagina with the uterus perched on top (Figs 13.11A and B). Even in babies a mucocolpos can result in a large abdominal tumour. If the obstructing membrane is thin and situated low in the vagina it can be seen bulging at the introitus; the underlying blood

gives it a bluish colour. Rectal examination is all-important to the diagnosis.

With atresia of the upper vagina or cervix, the patient is more likely to present with attacks of severe abdominal pain occurring at monthly intervals. The tumour then consists of a distended uterus, cervix or upper vaginal compartment, or combinations of these (Fig. 13.12). It is not likely to be as large as in the case of a classical haematocolpos because the severe pain forces the patient to seek advice at an earlier stage. If the lower vagina is absent, the swelling is usually only palpable on rectal examination.

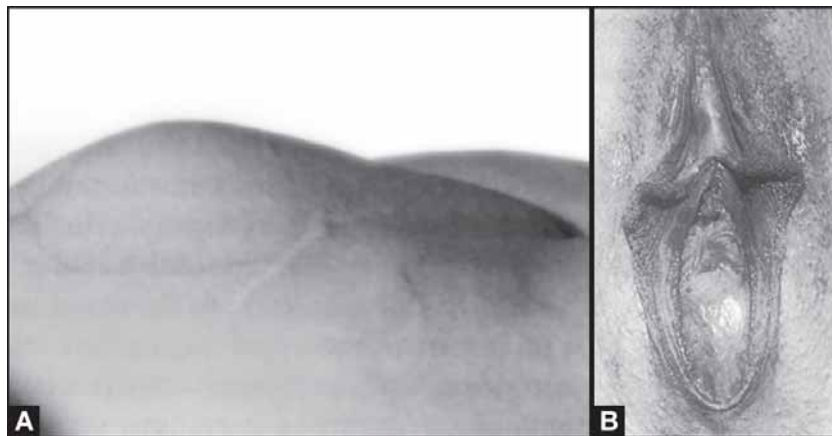
### Differential Diagnosis

Conditions most likely to be confused are pregnancy and tuberculous peritonitis, both of which cause amenorrhoea and a lower abdominal swelling; acute or subacute appendicitis - attacks of pain; all causes of true amenorrhoea; ovarian cyst; and pelvic kidney this is common when the vagina is absent and may be mistaken for a haematometra. Ultrasound helps in the diagnosis.

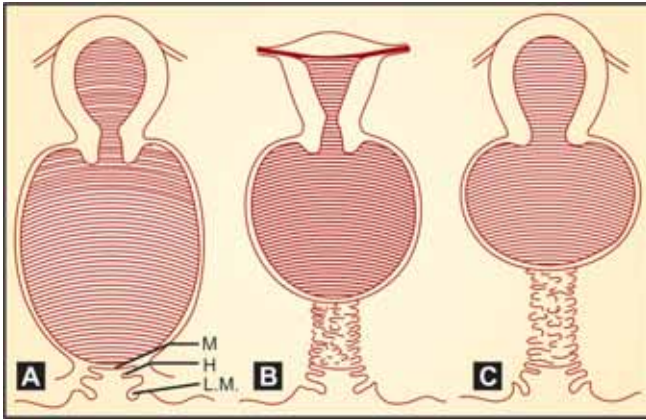
### Treatment

Once the diagnosis of cryptomenorrhoea is made, surgical treatment is urgently required since every menstrual episode further dilates the genital tract and threatens permanent impairment of reproductive function.

Obstruction at the level of the cervix is least often encountered but is the most controversial. The



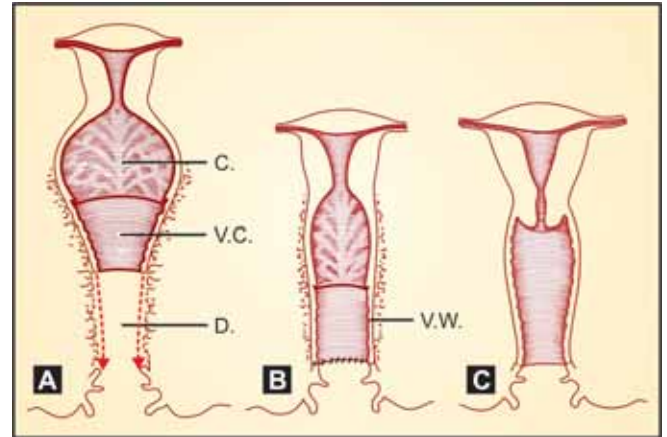
**Figs 13.11A and B:** (A) Haematocolpos resulting from an imperforate vagina producing, in a girl aged 15 years, a tumour which extends from the pelvis to the umbilicus, (B) The bulging membrane at the introitus, made dark by the underlying tarry blood



**Fig. 13.12:** Variations in vaginal congenital atresia and aplasia with haematocolpos and haematometra. (A) The classical imperforate vagina with only a thin obstructing membrane at the introitus. M - membrane; H - hymen; LM - labium minus, (B) A gross deficiency of the lower vagina resulting in a thick obstruction, (C) Most of the vagina is imperforate and clinically this is usually mistaken for complete absence of the vagina with cervical atresia causing a haematocervix and haematometra. In fact, even though a haematocervix is present there is always an upper compartment of vagina if the uterus is functional. The treatment of (A) is by simple incision or excision of the membrane. This treatment, however, gives poor results for (B) and (C) because the obstruction always reforms within a few hours or days (see Fig. 13.13).

conservative approach is of uterovaginoplasty, while the radical method is to perform a hysterectomy. The decision is based on the clinical features, psychological status, approach and experience of the surgeon and, not the least, the wishes of the patient and her family.

When the vagina is well developed and the uterus well formed and functional, uterovaginoplasty can be attempted by a combined abdominovaginal approach. This is a technically difficult operation in which the uterus and vagina are opened, the collected menstrual blood drained from the uterus and the posterior wall of the vagina sutured to that of the uterus. A Foley catheter is inserted through the vagina into the uterus and anchored there. The uterine body is then reconstructed and sutured to the anterior vaginal wall. The Foley catheter remains as a stent for 8-12 weeks to permit epithelialisation of the new tract. In patients with cervical atresia, restenosis may occur in 50 per cent and hysterectomy is then required. In some of these patients, severe sepsis may result and even the occasional fatality has been reported. All these patients have severe morbidity from the incapacitating pain. These features



**Fig. 13.13:** Advancement of the upper compartment of the vagina in dealing with all except minor degrees of lower vaginal aplasia or atresia causing a haematocervix, as shown in Fig. 13.12 (B) and (C). In the past such vaginal deficiencies were often dealt with by creating and skin grafting a lower vagina but the results are not always good and a stricture tends to form at the junction of the artificial vagina and the true vaginal compartment above. Once the diagnosis is made there is no need even for laparotomy. Careful dissection from below leads to the collection of blood above and after this has been released the upper vagina and cervix are mobilized so freely that they can be brought down to be sutured to the introitus. (A) A path through the obstruction is dissected (D) and the vaginal compartment and the cervix containing the menstrual blood (VC and C) are freed to be advanced to a lower level as indicated by the arrows, (B) The operation is completed, VW being the vaginal wall, (C) This shows the final result; the cervix returns to its normal shape and what was an upper compartment of vagina adapts to produce a vagina of good length

prompt many gynaecologists to recommend a hysterectomy to patients with cervical atresia. However, since these are young women, the psychological sequelae of such a radical step are tremendous, hence most surgeons nowadays attempt reconstructive surgery at least once. Pregnancy has occurred in some cases after creation of a neocervix and this fact further encourages surgeons towards the conservative approach. When the outflow of menstrual blood is prevented by a thick vaginal membrane at any level, incision of the latter alone is inadequate. The raw area in the vagina always seals over rapidly within days if not hours. It is therefore essential to cover any deficiency with vaginal epithelium; this is best done by dissecting free the upper vaginal walls and 'advancing' them downwards to be sutured to the margins of the vagina around the lower limit of the obstruction (Fig. 13.13). Alternatively, the raw area can be covered with a skin graft, as for the creation of an

artificial vagina, but this is usually unnecessary. Pregnancy following such procedures is not very rare and is often best terminated by elective caesarean section.

The treatment of the more common and typical case of haematocolpos, when the obstructing membrane is thin and low down, is simple. The membrane is merely excised (not incised) and the edges subsequently heal rapidly. However, this apparently minor operation demands great care over asepsis, as do the more complicated ones mentioned above. The vagina has been closed throughout life so it is without the protecting lactobacilli, its epithelium is poorly formed, and its reaction is alkaline or weakly acid. There is therefore little natural resistance to bacteria entering from below; indeed, the degenerated blood and debris offer a favourable medium for their growth. Postoperative salpingitis and peritonitis are therefore real hazards and, in the past, were sometimes fatal. Bilateral hydrosalpinges occur as late sequelae.

The fluid which escapes after removal of the obstruction resembles liquid chocolate. It is devoid of fibrinogen and prothrombin and contains mucins (from the cervix), lactic acid (from the blood), calcium and altered blood pigments. Its amount varies from 200 ml to 2 litres or more, and it may take several days to run away. Its escape should not be hurried by the insertion of a drainage tube or by intermittent pressure over the lower abdomen, because such procedures encourage the entry of organisms. For the same reason vaginal examination should be avoided and the state of the uterus and tubes left in doubt for 1-2 months. Meanwhile the vulva is kept covered with a sterile pad and the patient is discouraged from sitting in a bath.

At the end of the prescribed time, vaginal examination is carried out to see if there is any remaining evidence of haematometra or haematosalpinx. Fortunately, the uterus and tubes show enormous powers of recovery so that radical treatment such as salpingectomy and hysterectomy is rarely necessary. A high percentage of girls treated for haematocolpos later prove to be fertile.

Incomplete atresia such as stricture of the upper vagina is treated by dilatation or by incision and suture on the principles of plastic surgery. Occasionally, excision of fibrous tissue and coverage of the raw area by freeing the adjacent vaginal wall is necessary.

### OVARY

Malformations may affect one or both ovaries.

### Absence or Underdevelopment

*Absence of the gonads* is extremely rare and betokens a fundamental error in the formation of the urogenital ridge. I have seen women with testes instead of ovaries but never one without gonadal tissue of some kind. Rudimentary ovaries which are functionless or cease to function at an early age come under the headings of *streak gonads* and *gonadal dysgenesis* and are usually associated with errors in the sex chromosome pattern.

### Accessory and Supernumerary Ovaries

An *accessory ovary* on one or both sides is not uncommon but the condition as a rule is one in which a single ovary is divided into two portions which are attached to each other by fibrous tissue.

Nevertheless, true *supernumerary ovaries* or portions of ovarian tissue have been found in the broad ligament and elsewhere; they probably account for the occasional reports of menstruation continuing, and of pregnancy occurring, after the removal of both ovaries.

### Failure of Descent

The ovary may remain at the level of the pelvic brim or even near the lower pole of the kidney. Sometimes it is found in a hernial sac.

### Ovotestis

See page 224.

### FALLOPIAN TUBE

Malformations of the tube are described under müllerian duct anomalies. They include: absence in whole or part; underdevelopment; congenital atresia; excessive length; duplication; accessory tubes; diverticula; and accessory ostia.

### UTERUS

#### Absence

*Complete* absence of the uterus results when the müllerian ducts fail to develop and is often associated with an error in the sex chromosome make-up. The upper vagina is inevitably absent as well. If the fallopian tubes or their fimbriated extremities are present, they taper inwards to a transverse fold — the plica *transversalis*.

## Hypoplasia

### Types

Hypoplasia of the uterus occurs in varying degrees as the result of an error in either antenatal or postnatal development. Sometimes the organ consists of nothing more than a small nodule of solid or hollow functionless tissue, a condition often mistaken for absence of the uterus. The uterus may, however, be essentially normal in shape and structure yet have reduced dimensions. Persistence of the infantile proportions in which the cervix is long in relation to the corpus is another feature.

### Causes

- An inherent error in müllerian duct tissues, often associated with sex chromosome abnormality, resulting in a uterus which is incompletely formed or which is incapable of responding to the normal postnatal growth stimulus of oestrogen.
- Failure of the ovaries and adrenals to supply the oestrogen stimulus to a basically normal uterus at the time of puberty.
- Some disease or circumstance which destroys oestrogen or nullifies its effect on the uterus.

### Clinical Features

The traditional symptoms of uterine hypoplasia are *primary amenorrhoea*, *late menarche*, *infrequent menstruation* and *infertility*. All except the first are more likely to be manifestations of an underlying ovarian inactivity than of the uterine abnormality. There is no reason why smallness of the uterus *per se* should prevent conception or alter the ovarian cycle. *Scanty menstruation (hypomenorrhoea)* may be a symptom but is often found with normal-sized uteri. Some believe that the first pregnancy is more likely to abort if the uterus is hypoplastic but the evidence for this is insecure.

On examination the uterus is found to be small in overall length and width, although the cervix may be relatively long. The endometrium is thin.

When the complaint is *secondary amenorrhoea*, the finding of a small uterus means *atrophy* rather than *hypoplasia*; it is sometimes difficult, if not impossible, to distinguish between these two states.

### Diagnosis

The diagnosis of uterine hypoplasia is made all too frequently on a mere impression that the uterus feels

small on bimanual examination. Indeed, uterine hypoplasia is more often a convenient label than a proven state, especially in cases of infertility where the cause is unknown. The essential criteria of uterine hypoplasia are: a subnormal menstrual cycle; a uterine cavity measurement of 6 cm or less; and an endometrium which appears unstimulated on microscopy. All must be present.

### Treatment

Treatment needs to be directed at the cause. The results of treatment with exogenous oestrogens are unsatisfactory for the following reasons:

- If hypoplasia is the result of the uterus being unresponsive to the ovaries, oestrogens have no effect on it.
- If hypoplasia is the result of an inadequate ovarian stimulus then oestrogens will promote full development of the uterus, but the effect is temporary and, unless ovarian function becomes normal in the meantime, the uterus returns to its former state when treatment is suspended.

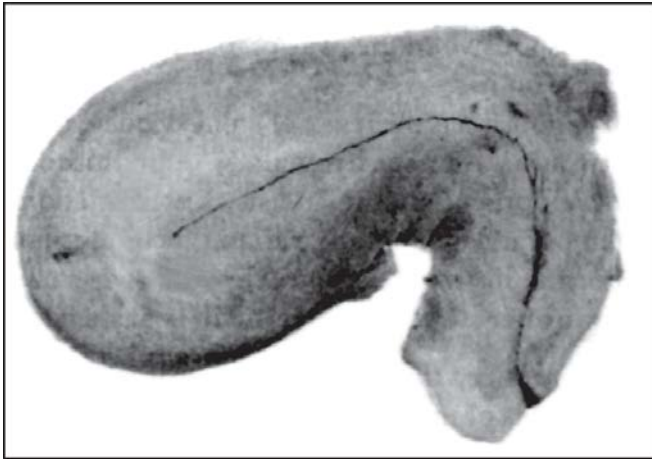
In practice, therefore, the administration of oestrogen is of more value as a diagnostic than as a therapeutic procedure. It may be added that, when the complaint is infertility, attention should be directed to establishing normal ovarian function rather than correcting the consequential uterine hypoplasia.

## Cochleate Uterus

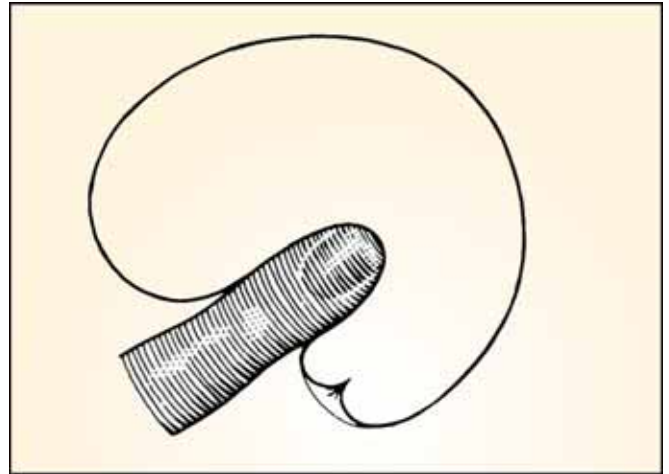
### Pathology

In young nulliparous women, it is not uncommon to find a uterus which is cochleate or C-shaped when viewed from the side. The position of the body of the uterus is normal and the deformity arises because the cervix is angled forwards. The condition is therefore also called *acute ante flexion of the cervix*. (Fig. 13.14). A similar malformation in reverse can occur when the body of the uterus is directed backwards and is a common feature of congenital retroflexion of the uterus. In these states the cervix is usually longer, narrower, and more conical than normal, the corpus being well developed.

Menarche is at a normal age and menstruation is free and regular. A cochleate uterus should therefore be regarded as being maldeveloped rather than underdeveloped, the site of the trouble being at the level of the internal os. The deformity nearly always disappears after pregnancy.



**Fig. 13.14:** Acute anteflexion of the cervix (cochleate uterus)



**Fig. 13.15:** Acute anteflexion of the cervix determined clinically by apposition of the body of the uterus and of the cervix to the sides of one finger

#### *Clinical Features*

A cochleate uterus rarely gives rise to symptoms and its finding is incidental. There is a greater likelihood of spasmodic dysmenorrhoea, possibly because of disturbed uterine polarity. When both the body of the uterus and the cervix can be defined, the acute angle between them can be demonstrated by being able to feel each lying in close contact with opposite sides of one finger (Fig. 13.15).

#### *Treatment*

Treatment is directed to the symptoms, if any.

#### **Conical Cervix and Pinhole os**

The normal cervix varies in shape and size but occasionally it is so conical, or its external os appears so small, as to warrant these descriptions. Conical cervix and pinhole os often go together and the cervix as a whole tends to be long and narrow. These diagnoses are largely a matter of fashion and personal opinion; at present they are out of fashion.

#### **Congenital Hypertrophy of Cervix**

This condition is developmental rather than congenital, and a malformation rather than hypertrophy. Congenital hypertrophy of the cervix is, in fact, merely a name for an unusually long cervix. The elongation affects the vaginal rather than the supravaginal cervix and the

diagnosis is only made in nulliparous women. The condition is usually symptomless. Sometimes the cervix is so long that the patient is conscious of it during straining and during coitus; this is particularly true if the vagina happens to be short.

#### **VAGINA**

##### **Absence**

#### *Pathology*

The vagina may be completely absent (Fig. 13.1) or, more often, the müllerian duct portion is absent and the urogenital sinus part is present as a depression of variable depth. The condition can be associated with intersexuality, but in otherwise apparently normal women the sex chromosomes are usually XX.

#### *Clinical Features*

If the uterus is present and functional, an upper compartment of the vagina is invariably present, and a deep-seated haematocolpos and haematocervix develop after puberty. These cause monthly attacks of pain associated with apparent amenorrhoea. If the uterus is functionless, the complaints are primary amenorrhoea and dyspareunia or apareunia. In fact, absence of the vagina is usually diagnosed during the investigation of amenorrhoea before marriage.

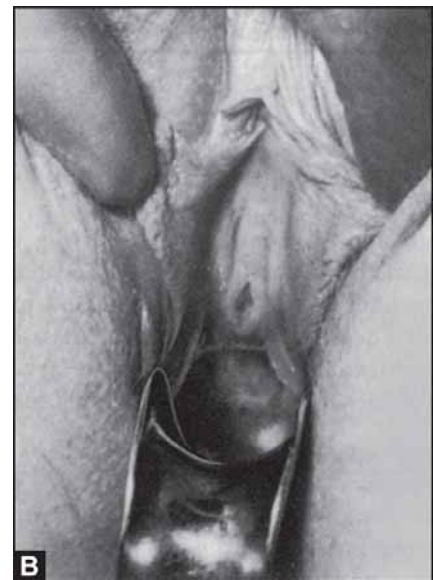
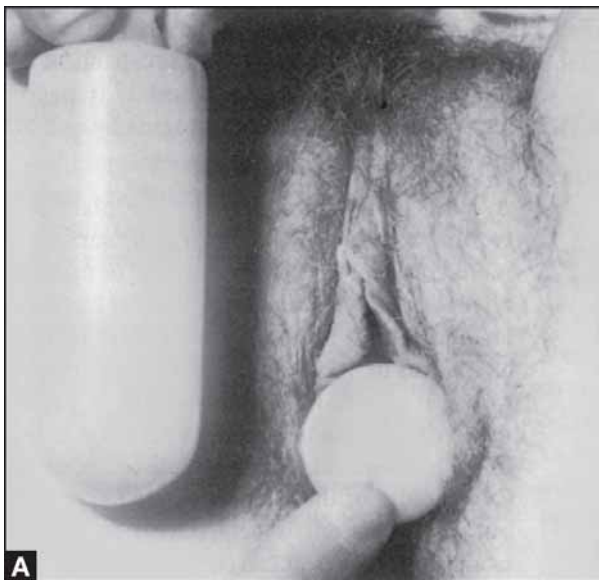
Treatment

If cryptomenorrhoea is present, a plastic operation can be carried out to connect the upper vagina and uterus to the lower vagina and introitus (Fig. 13.13). In neglected cases hysterectomy may be necessary.

If the aim is merely to permit coitus then it is usually advised that treatment should be deferred until 6-9 months before marriage, and that a plastic operation should only be carried out with the knowledge and consent of the partner. This attitude rarely deserves modification, even though there are young women who consider it unfair to encourage a proposal of marriage until their physical handicap has been corrected as far as possible. Several lines of treatment are available.

If the lower vagina is present as a depression or pouch, then continued or repeated pressure with an obturator (or repeated attempts at coitus) over the course of several months will often stretch the vagina sufficiently to allow reasonably normal coitus. Success or failure with this method depends very much on the outlook and determination of the patient. In this respect the patient should always be told that the vagina is underdeveloped rather than absent; this encourages in her the idea that it is capable of being stretched. The same holds good if it becomes necessary to create an artificial vagina by one of the following methods.

- A space is dissected between the bladder and rectum and lined with a skin graft carried on a mould made of light plastic material or foam. Even after the graft has taken, the patient has to wear an obturator or mould for at least 6 months afterwards to prevent contracture, and may have to use it indefinitely unless coitus is practised regularly. The danger of the operation is injury to the bladder and rectum with fistula formation. Contracture of the artificial vagina is common, but, if the patient is determined to get coitus established, the result can be very satisfactory (Figs 13.16A and B). A rare late sequel to this type of operation is enterocele formation.
- A more recent development has been the use of an amnion graft instead of a skin graft. The dissection is as above but the mould is covered with amnion (obtained under sterile conditions at a caesarean section delivery and kept in sterile solution until used). The mould is sutured *in situ* and removed after 7 days. The vagina is washed out. A new mould with amnion may be inserted for a further 5-7 days. The epithelium of the lower part of the vagina appears to grow over or into the amnion and therefore gives a more satisfactory end result than a skin graft, in my opinion.
- A pouch superficial to the vestibule, and opening anteriorly, is created by suturing together a linear



**Figs 13.16A and B:** Artificial vaginas created surgically by dissection and skin grafting of a space between the bladder and rectum. Photographs taken one year after the operations, (A) The vulva looks normal and the vagina accommodates a good-sized obturator. This is one type of light plastic obturator which the woman inserts and wears regularly to prevent contracture. (B) A second case with the artificial vagina demonstrated by means of a Sims' speculum

U-shaped incision in the hairless aspects of the labia majora (*Williams' operation*). This is a simple and safe procedure. Once coitus is established, it permits a gradual indentation of the vestibule to lengthen the available canal. However, the angle of the neo-vagina is not physiological. Also, if the pouch is too close to the urethra urine can collect in it. This method is sometimes used for patients with a pelvic kidney or following radical surgery.

- Muscle and skin flaps have also been used for reconstruction of the vagina following radical surgery. The gracilis myocutaneous flap has a high failure rate due to vascular problems. Neuro-vascular pudendal-thigh flaps (the Singapore flap) are reported to have better blood supply and innervation.
- The labia majora and minora have been used to create a satisfactory vagina but this distorts the vulvar anatomy. Labiovaginal flaps created by tissue expansion techniques have been used to overcome this problem.
- Operations involving the transplantation of an isolated loop of colon into a space dissected: between the bladder and the rectum are described. They are unjustified for congenital absence of the vagina but may be used following radical cancer surgery (pelvic exenteration).
- Laparoscopic techniques using an olive device which exerts traction on the pseudohymen through the abdominal wall have been used (Vuchietti's method), but the device has not been approved by the FDA.

Before any of these operations is undertaken, the presence of associated kidney malformations and impairment of renal function should be excluded.

**Nonsurgical Approach** (Frank Procedure): The Frank technique was initially described in 1938. The goal was to increase the depth and caliber of the vagina with the use of graduated dilators, thus avoiding the need for surgical intervention. The Ingram "bicycle seat" represented a dramatic improvement in the Frank procedure. The major advantage of this racing-type bicycle seat is that it is positioned between the buttocks and is therefore in better contact with the perineum, providing direct pressure from the graduated dilator on the incompletely developed vagina.

In the Franks nonsurgical method firstly, the patient is instructed to use a mirror to examine her genitalia at home, identifying the external structures and introit

dimple. Dilators of graduated sizes are used to create pressure on the vaginal dimple, beginning with a dilator approximately 1.5 cm in diameter and 2 to 3 cm in length. The same is used for 20 to 30 minutes three to four times daily. She should be seen monthly, not only for physical evaluation but also for continued encouragement and motivation; she should be made aware that consistent use of this technique will enable her to avoid surgery and will eliminate the risk of postoperative scarring and the need for painful, potentially disfiguring skin grafting. Steady progress should be readily apparent on periodic pelvic examination. Adequate vaginal caliber and depth can usually be demonstrated in 14 to 16 weeks.

On occasion, the position may be difficult to manage because of the shallowness of the vaginal dimple. In these cases, the patient can begin with the lithotomy position, applying manual pressure to hold the dilator firmly in contact with the vaginal dimple until there is sufficient invagination to accommodate the bicycle technique comfortably. Some women can pedal a stationary bicycle during dilatation after several weeks of nonsurgical treatment, but this should be discontinued if there is any chafing or discomfort. The Ingram technique is successful in approximately 90 per cent of cases, and Ingram himself contended that surgery should not be considered until the patient had undergone a sufficient trial of this approach.

The Franks and the Ingram technique is successful in a fair number of girls and can be considered until the patient has undergone a sufficient trial of this approach.

### Vaginal Hypoplasia

Vaginal hypoplasia is evidenced by shortness, narrowness, shallow fornices and by thin and inactive epithelium. It is caused either by an inherent fault in the müllerian ducts or by absence of the oestrogen stimulus from the ovary. In the latter case it is always associated with uterine hypoplasia and can be overcome by oestrogen therapy.

This treatment is worthwhile if the complaint is dyspareunia because, once the vagina is well formed, it does not contract back to its former state so long as coitus is continued regularly.

### Congenital Atresia and Stricture

*See page 205.*

## Septate and Subseptate Vagina

See page 200.

## Double Vagina (duplication)

This is extremely rare, occurring in association with double vulva, double uterus, double bladder and urethra, and sometimes with supernumerary lower limbs (Fig. 13.17). The condition really represents an included twin. In most cases labelled 'double vagina' the vagina is single but septate.

## VULVA

### Absence, Gross Underdevelopment and Duplication

These curiosities are usually only found with other malformations incompatible with life (Fig. 13.17).

## Hypoplasia

This is seen in association with hypoplasia of the rest of the genital tract in states of hypo-oestrogenism (for example, infantilism, streak gonads). The secondary sex characters are poorly developed as well.



**Fig. 13.17:** Duplication of the vulva in a baby which died from multiple malformations 7 weeks after birth. There was a single anus and rectum but two bladders, a uterus didelphys and a 'double' vagina. There were only two kidneys, one grossly hydronephrotic

## Bifid Clitoris (*Diphallus*)

The genital tubercle is formed from *two* mesodermal bands which grow round from the dorsal aspect of the foetus in the third week. These also provide for the musculature of the abdominal wall, the musculature of the anterior walls of the bladder and urethra, and the symphysis pubis. Failure of these bands to develop properly or to fuse results in a bifid clitoris (bifid or double penis in the male), ectopia vesicae, epispadias, a muscular defect of the lower abdominal wall, divarication of the foreparts of the labia majora, absence of the hair-bearing skin of the pubes and a split pelvis (Figs 13.18 and 13.19).

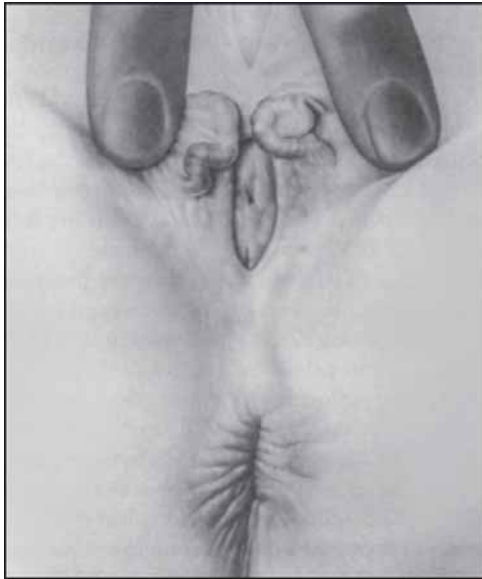
The vulvar deformity is often associated with shortness of the vagina and stricture of the introitus and there is strong predisposition to uterine prolapse.

For this condition, the primary object of treatment is to close the bladder wall anteriorly but it is often necessary to divert the urinary stream to ensure some sort of continence. I know of three cases in which the ureters were transplanted to the colon in childhood and in which the women remained healthy 15-20 years later. One of these women had two normal pregnancies followed by easy vaginal deliveries.

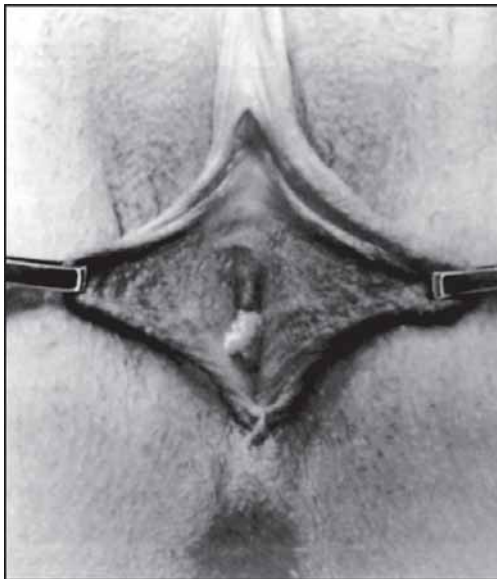


**Fig. 13.18:** Split pelvis in a woman aged 21 years suffering from ectopia vesicae and bifid clitoris. Her urinary incontinence was controlled by transplantation of the ureters into the pelvic colon at the age of 10 years. There was normal renal function and electrolyte balance 11 years later





**Fig. 13.19:** Bifid clitoris, and divarication of the labia associated with a defect of the lower abdominal wall, ectopia vesicae and split pelvis



**Fig. 13.20:** Bilateral hypertrophy of the labia minora in a virgin aged 14 years. She complained of recurrent discomfort caused by abrasion so the labia were trimmed down to size by a simple plastic procedure

### Hypertrophy of the Clitoris

See Chapter 14.

### Abnormalities of the Hymen

The hymen may be absent, imperforate or tough. The last causes apareunia.

### Atresia of the Labia Minora

In the young female embryo, the genital folds may fuse as they do in the male. The introitus then becomes enclosed by a membrane which represents the two labia minora, with an exit for urine anteriorly. This is a feature of congenital adrenal hyperplasia and can be caused by any virilising agent acting on the foetus before vulvar development is complete.

In most cases of fused nymphae seen in children aged 1-3 years, the abnormality is the result of adhesions forming after acute vulvitis of infancy rather than an error in development.

### Hypertrophy of the Labia Minora ('spaniel ear nymphae')

#### Pathology

Hypertrophy may affect one or both labia minora and does not ordinarily become obvious until puberty. It is sometimes stated that bilateral hypertrophy of the labia minora is the result of masturbation. There is no doubt that manipulation and stretching of the labia as practised by some primitive tribes can lead to their permanent gross enlargement. Nevertheless, the hypertrophy seen in civilised communities is rarely attributable to anything more than a developmental peculiarity (Fig. 13.20).

#### Symptoms

Usually there are no symptoms but the patient may complain of a 'tumour' or of 'something hanging' from the vulva. If the labia are very long they can become chafed, oedematous and ulcerated during exercise. Such symptoms are mostly seen during adolescence when there is a tendency for leucorrhoea and uncleanliness.

#### Treatment

No treatment other than reassurance and attention to hygiene is usually necessary. Talcum powder should be avoided because it cakes in the crevices. A barrier cream, or zinc and castor oil cream, can be applied before exercise. If these conservative measures fail, the size of the labia can be reduced by a simple plastic operation which gives excellent results.

### Asymmetry of the Labia Minora

Like all paired organs, the labia minora are often unequal in size. One may be unusually large or small (Fig. 13.21). The condition is rarely more than of interest; often the patient is unaware of the inequality.

No treatment is necessary unless the larger labium causes chafing, when its size can be reduced surgically.

### ERRORS ARISING IN CONNECTION WITH THE CLOACA

Defects in the proper partition of the cloaca into the hindgut and urogenital sinus result in: a persistent cloaca with a common opening for the bladder, vagina and bowel (this is extremely rare); a fistula between the rectum or anus and the vagina; a *perineal, vestibular* or *vaginal anus* (Fig. 13.22); or an *imperforate anus*.

A perineal or vaginal anus is not too uncommon and is characterised by a deficiency in the perineal body and by the lower bowel opening low down on the posterior vaginal wall or at the fourchette. A vaginal anus is usually recognised in the newborn, and is distinguished from imperforate anus by the escape of meconium from the vagina. Nevertheless, it is the subject of much unnecessary and harmful surgery in children. Rarely, the anus is so narrow as to obstruct the passage of meconium. In that case a simple 'cut back' operation is

indicated and does not generally result in faecal incontinence in later life. Usually the opening is sufficiently large not to obstruct the bowel and, in that case, should be left alone. The baby, as it grows, develops quite a good sphincter control. In adult life, the individual suffers little or no inconvenience but, if the opening is high and the vagina gets badly contaminated, a reconstruction operation may be necessary before marriage. A high vaginal anus is exceptional and is usually associated with a failure in development of the lower rectum, the pelvic floor and the sacrum. As a rule, however, no surgery is necessary at any age.

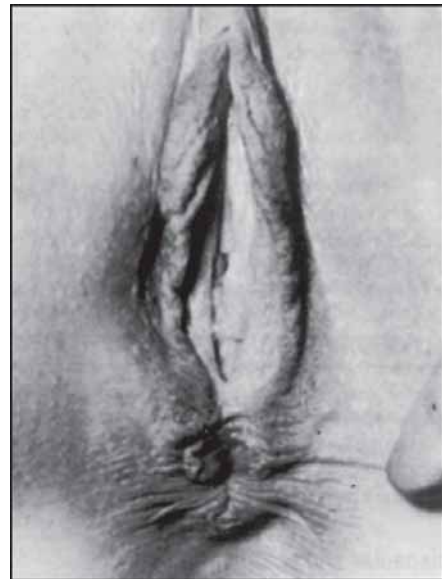
A perineal anus is only a problem during childbirth when the thin rectovaginal septum is vulnerable to trauma in the second stage of labour. A rectovaginal fistula with faecal incontinence is not an inevitable result but the risk is sufficient to justify elective caesarean section in many of these cases.

If it does become necessary to transplant a vaginal or perineal anus backwards, one of the difficulties is to provide it with a sphincter. The operation may have to be preceded by temporary colostomy.

An *imperforate anus* results when the cloacal membrane over the hindgut fails to break down or when the division of the cloaca leaves a blind lower end of the bowel. The latter can be some distance away from the ectoderm in which case surgical correction of the error



**Fig. 13.21:** Unequal development of the labia minora, which is a common finding. Vaginal prolapse is also present in this case



**Fig. 13.22:** Perineal anus. The anus is just outside the fourchette; sometimes it opens nearer to or just within the vagina

can be difficult. All babies should be examined at birth to see if the anus is perforate; if it is not, operative treatment is urgent.

### MALFORMATIONS OF THE URINARY TRACT

Some of these come within the remit of the gynaecologist and some have already been mentioned. They often occur in association with abnormalities of the uterus, vagina and vulva.

#### Epispadias and Ectopia Vesicae

See page 214.

#### Urethral Diverticula

See chapter 27.

#### Accessory and Aberrant Ureter (and kidney)

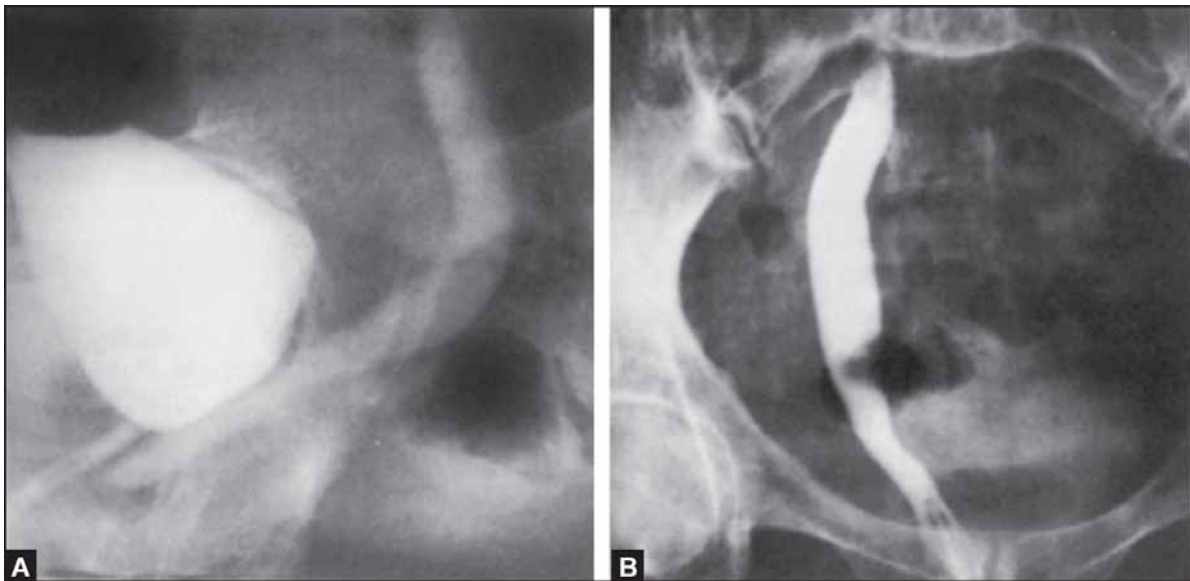
Duplication of the renal pelvis and ureter is common and arises as a result of an accessory ureteric bud from the wolffian duct (Figs 13.23A and B). The accessory ureter always links with the upper pole of the kidney

and crosses posterior to the main ureter. Its importance is that it may be injured during pelvic operations because the surgeon is usually unaware of its existence.

Sometimes the ureter, but more often an accessory ureter, opens into the anterolateral wall of the uterus, the vagina, the vestibule or the urethra; the commonest site is the vestibule. It then causes incontinence of urine which is frequently mistaken for enuresis in childhood. The amount of urine which escapes can be small and intermittent so, bearing in mind that micturition is otherwise normal, the leakage may be regarded as vaginal discharge. An aberrant ureter may become infected.

The diagnosis of an accessory ureter can be extremely difficult and sometimes eludes the expert for years. That part of the kidney served often has poor function, so neither it nor the ureter may be revealed by intravenous pyelography. Moreover, the opening on the vestibule or elsewhere is usually tiny and difficult to locate unless a bead of urine happens to escape at the time of examination.

Treatment is by excision of the aberrant structure and of the kidney tissue which it drains.



**Figs 13.23A and B:** Bilateral aberrant ureters. In this case a girl, when aged 12 years, had bilateral aberrant kidneys and the upper parts of their ureters removed. She remained symptom-free until her first pregnancy at the age of 22 years when she developed what was first thought to be stress incontinence of urine. Investigation then showed that the pelvic parts of the aberrant ureters were still present; the left one entered the bladder just above the internal urethral meatus and caused no trouble. The right one opened into the urethra at a low level and is here shown as the dilated structure lying behind the bladder and upper urethra. It was removed successfully, (A) Lateral urethrocytogram with the aberrant right ureter filled from below with radio-opaque medium, (B) Anteroposterior exposure of the lower part of the right aberrant ureter



**Fig. 13.24:** An intravenous pyelogram showing three separate kidneys, a normal one on the right, a hydronephrotic one on the left, and one in the left side of the pelvis. The site of the last is typical for a pelvic kidney. This situation was discovered during the investigation of a girl aged 16 years complaining of primary amenorrhoea and who had the stigmata of Turner syndrome including stunted growth and webbing of the neck. She was nevertheless chromatin-positive and later menstruated normally so she did not have streak gonads. The sex chromosome pattern was not determined but was almost certainly abnormal

### Absence of One Kidney and Ureter

This is commonly associated with absence of the müllerian duct on the same side or with gross malfusion deformities of the uterus (Fig. 13.2).

### Fusion of the Kidneys - Horseshoe Kidney

#### *Pelvic Kidney*

Failure of the kidney to ascend results in a pelvic kidney which lies extraperitoneally, sometimes at the pelvic brim but more often below the brim in front of the sacroiliac joint (Fig. 13.24). It is more likely than a normal kidney to develop hydronephrosis and pyonephrosis. It may present merely as a pelvic tumour, palpated during vaginal examination, or obstructing labour. It is usually mistaken for an ovarian tumour and this sort of error can only be avoided by keeping the condition in mind, and by carrying out pyelography in the case of any tumour of the right size and position which is more fixed than an ovarian cyst.

A pelvic kidney, or a single horseshoe kidney in the pelvis, is not uncommon in cases of vaginal agenesis. It can be mistaken for a haematometra.

# CHAPTER 14

## Sex Determination, Asexuality and Intersexuality

Intersex	219	Psychological Sex	238
Sex Determination in the Foetus and its Anomalies	220	Sex of Rearing	240
Chromosomal Sex	221	The Management of Aberrations of Sex Present at Birth	240
Hormonal Intersex	232	Intersex Developing After Birth	244

The sex of an individual is not a singular entity but is dependent on various factors.

Normal sex of an individual is determined by the following factors:

1. Chromosomal sex (Genetic sex)
2. Gonadal Sex
3. Hormonal Sex (secondary sex characteristics)
4. External anatomical sex
5. Internal anatomical sex
6. Sex of rearing
7. Gender role (Societal role).

Intersexuality can be defined as a condition of imperfect sexual differentiation into either male or female. It is a relative term because no human being is completely male or female. Each carries the rudiments of the sexual apparatus of the other; many men are slightly effeminate and many women slightly masculine in bearing and outlook. A man may be rather smooth skinned or fastidious about dress, and a woman may be flat-chested or have hairy legs, without its being significant. Indeed, the borderline between a normal and an abnormal degree of intersex is vague and impossible to define. Gender identity is determined by the genetic, gonadal and phenotypic sex and is influenced by social mores and environmental upbringing.

### Physiological Considerations

Every human foetus is destined to be a female foetus. Early embryo is potentially bisexual upto 6th week of intrauterine life. Hormone influences triggered by genetic make up will cause müllerians atrophy and formation of male organs. In presence of TDF (Testes determining factor) and Y chromosome and the SRY gene on short arm of Y chromosome; the testes develops and MIF (Müllerian inhibiting factor) causes Müllerian degeneration and formation of scrotum and penis.

While in XX chromosomal make up there is no MIF and this causes development of Müllerian system (vagina, uterus and fallopian tubes).

### INTERSEX

Intersex is defined as a gross discrepancy in factors that define sex.

*Classification:* There is an original old classification of sex and intersex.

1. Sex chromosomal intersex
2. Autosomal intersex
3. Gonadal intersex
4. Hormonal intersex
5. Psychological intersex
6. Sex of rearing

The newer classification of intersex is as follows:

1. Deletion syndromes of Y lines (45X, 46XY)
2. 46 XY
  - a. Gonadal dysgenesis (Swyer's syndrome)
  - b. Empty pelvis: agonadia
  - c. Enzyme deficiency
    - i. Affecting both adrenals and testes
      - P-450
      - 3  $\beta$ -HSD
      - 17  $\alpha$  hydroxylase
    - ii. Affecting testes
      - 17  $\alpha$  hydroxylase
      - 17 HSD
      - 5  $\alpha$  reductase
  - d. Androgen insensitivity/resistance
    - Complete
    - Incomplete
  - e. Defect in synthesis/secretion/response to AMH
    - Persistent müllerian duct syndrome
  - f. Non-sex chromosome defect
3. 46 XY true hermaphrodite  
46 XX true hermaphrodite
4. 46 XX
  - a. 46 XX sex reversal male
  - b. Congenital adrenal hyperplasia
    - 21 Hydroxylase deficiency
    - 11  $\beta$  Hydroxylase deficiency
    - 3  $\beta$ -01-dehydrogenase deficiency
  - c. Aromatase deficiency (placental)
  - d. Material Androgens
    - Drugs
    - Tumours of pregnancy
  - e. Non-sex chromosome defects.

In the past, the gross and bizarre types of physical intersex were described as examples of hermaphroditism. This word derives from the name of a bisexual Greek god, Hermaphroditos, the offspring of Hermes and Aphrodite. Although true hermaphroditism implies the possession of the reproductive *function* as well as the genital apparatus of both sexes, as is the case in the earthworm, human individuals found to possess both ovarian and testicular tissue are sometimes described as

*true hermaphrodites*. An association of the gonads of one sex with the secondary sex organs of the other is termed pseudohermaphroditism. If the gonads are testes, the individual is said to be a *male pseudohermaphrodite*; if they are ovaries, the individual is a *female pseudohermaphrodite*.

Classifications of this kind not only impose a narrow outlook on intersex, they imply that the nature of the gonad is the criterion of sex. This view is no longer medically acceptable. As will be clear from what follows, a woman is not a woman because she has ovaries; she has ovaries because she is a woman or, better still, because she is not a man. Femininity is a neuter state and masculinity is a superimposed characteristic. Destruction of the gonads of the young male embryo results in its developing a female genital apparatus. Castration after birth, especially if performed at an early age, results in a eunuch who has many female qualities. Removal of the ovaries at any stage in life, on the other hand, does not lead to masculinity.

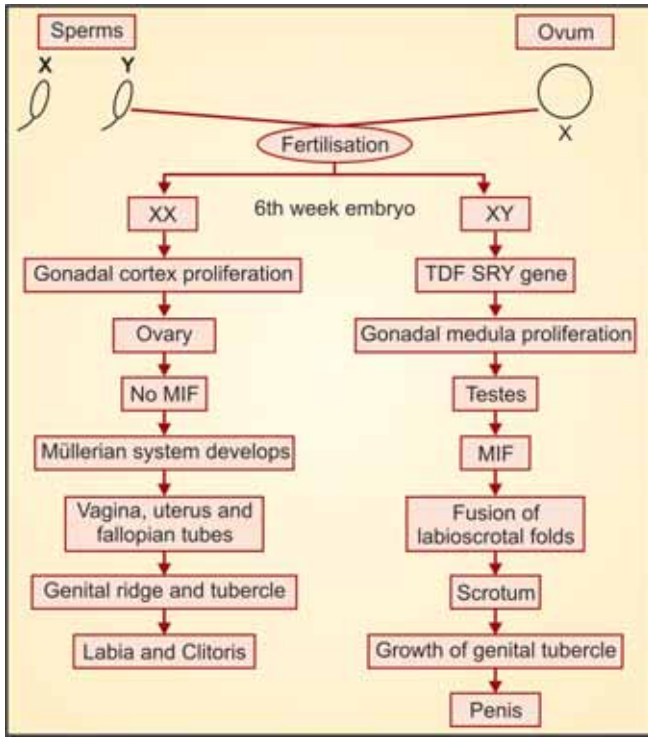
The sex of an individual cannot be judged by any one feature, not even by the number and type of sex chromosomes or the histological characters of the gonad. More important than these, both to the individual and to the community, are the secondary sex characters such as the external genitalia, breasts, voice and facial hair. Community interests are concerned when it comes to the rights of individuals to marry or partake in women's athletics. In the first case, genital sex is all-important. In the second, chromosomal sex can be the main criterion. It is currently used to screen women competitors only in the Olympic games. Other amateur organisations now perform only physical examination. It follows that terms such as male and female pseudohermaphroditism should be abandoned in favour of the non-committal term intersexuality.

## SEX DETERMINATION IN THE FOETUS AND ITS ANOMALIES

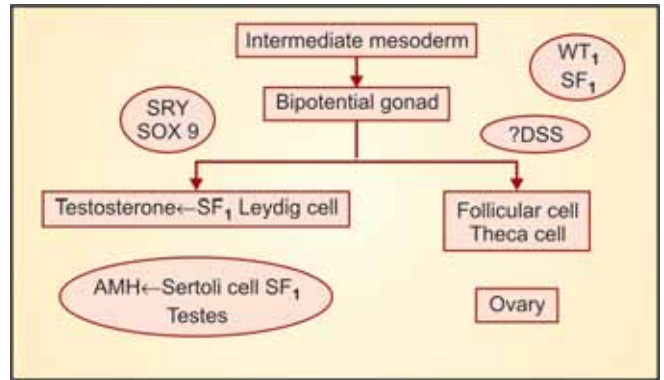
Of the several factors that determine sex in the foetus, none is all-powerful and decisive. The action of each can be modified by that of the others. This explains why states of physical intersex and incomplete sex, present at birth, assume so many forms and are difficult to classify.

After the genetic determination of sex and triggering of formation of ovaries or testes the hormonal influence of sexual development occurs (Flow charts 14.1 and 14.2).

Flow chart 14.1: Sex determination of embryo



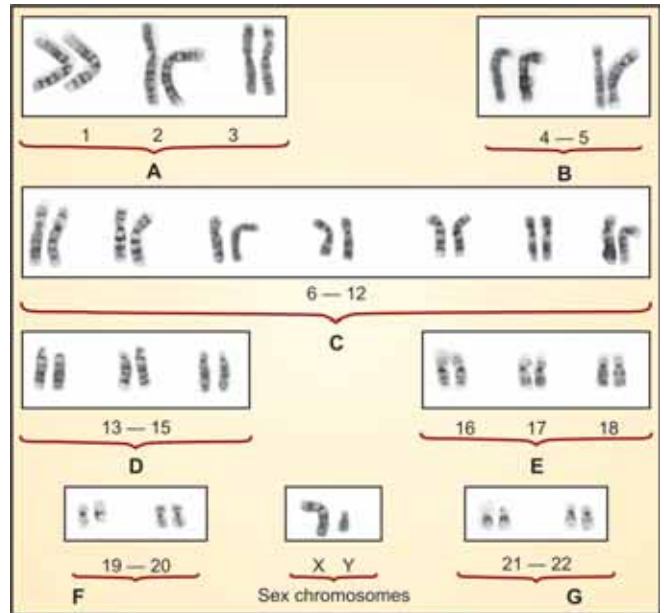
Flow chart 14.2: Genetic pathway



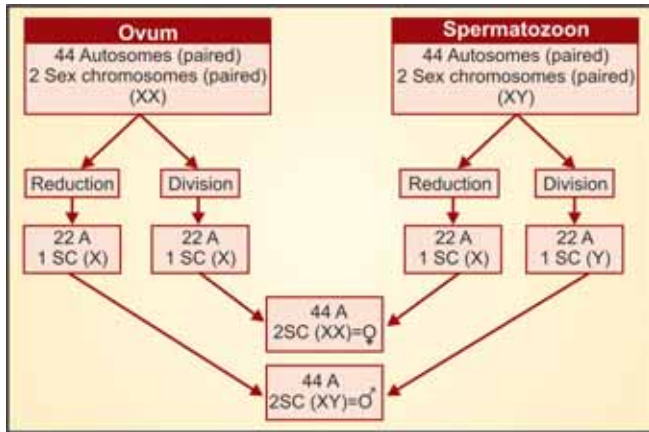
Statistically it might be expected that this mechanism would produce equal numbers of the two sexes. In fact, the sex ratio among very early embryos is said to be 160 males to 100 females. Two of the reasons postulated for this are: the uterus is more receptive to males than females; and the Y-carrying spermatozoa are either present in greater numbers in the semen or have smaller heads and greater vigour which give them an advantage in penetrating the capsule of the ovum. The sex ratio at

**CHROMOSOMAL SEX**

Sex is primarily determined at the moment the ovum is fertilised, by the type of sex chromosome supplied by the spermatozoon. The chromosomal pattern, even the sex chromosomal pattern, varies in different animals but the nucleus of every cell of the human body normally carries 46 chromosomes arranged in 23 pairs. One of these pairs, the sex chromosomes, is mainly concerned with sex; the remaining 22 pairs are designated autosomes (Figs 14.1 and 14.2). In the female the two sex chromosomes are similar -XX, the upper arms of the X being much shorter than the lower. In the male they are dissimilar - XY, the Y being a much smaller structure than the X and having very short upper arms (Fig. 14.1). As a result of reduction division, the mature ovum carries 22 separate autosomes and one X sex chromosome. Mature spermatozoa, however, carry either an X or a Y chromosome and are therefore of two types. If one type fertilizes the ovum, it contributes an X chromosome to result in a female zygote whose karyotype is expressed as 46,XX; if the other is operative the outcome is a male with the karyotype of 46,XY.



**Fig. 14.1:** The 23 pairs of chromosomes in the normal human male, numbered according to an internationally agreed system. The chromosomes are obtained from cultures of lymphocytes or fibroblasts and identified from a metaphase spread using special stains (in this case G banding using Giemsa stain plus trypsin)



**Fig. 14.2:** The normal distribution of autosomes (A) and sex chromosomes (SC) before and after reduction division of the ovum and spermatozoon, and after fertilisation

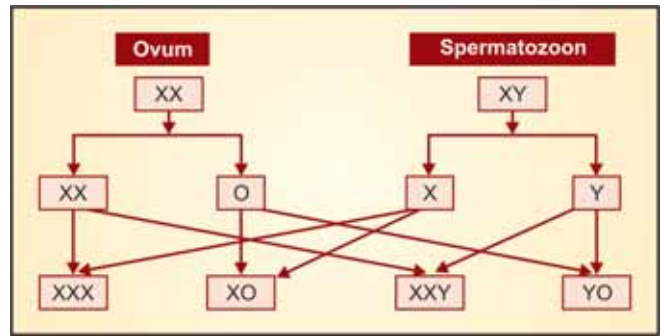
birth, however, is only 106 boys for every 100 girls. The suggested explanations for this apparent discrepancy are: the estimate of the number of male zygotes quoted above is incorrect, and this may well be if they are based on nuclear chromatin studies; and male embryos have a special susceptibility to death *in utero* at an early stage in development.

Throughout their length, all chromosomes carry genes at specified points - gene loci - each one of which is known as an *allele*. These are paired, as are the chromosomes. The X and Y chromosomes carry paired genes as do the two X chromosomes in the female. This pairing is essential for the genes to have an overt effect and if only one of a pair of chromosomes carries a particular gene its influence is usually recessive, except in the case of certain genes associated with malignancies, e.g. p53, BRCA and the retinoblastoma gene.

In addition to being concerned with sex, the sex chromosomes also have loci for genes that determine other characteristics of the individual. The X chromosome, for example, has at least 100 markers for features such as colour vision and the enzymes of red blood corpuscles. This explains why colour blindness and several inherited diseases are sex linked.

### Errors in Sex Chromosome Division and Distribution

During cell division the chromosomes normally split longitudinally, one half of each going to each of two daughter cells. When cleavage does not take place, the



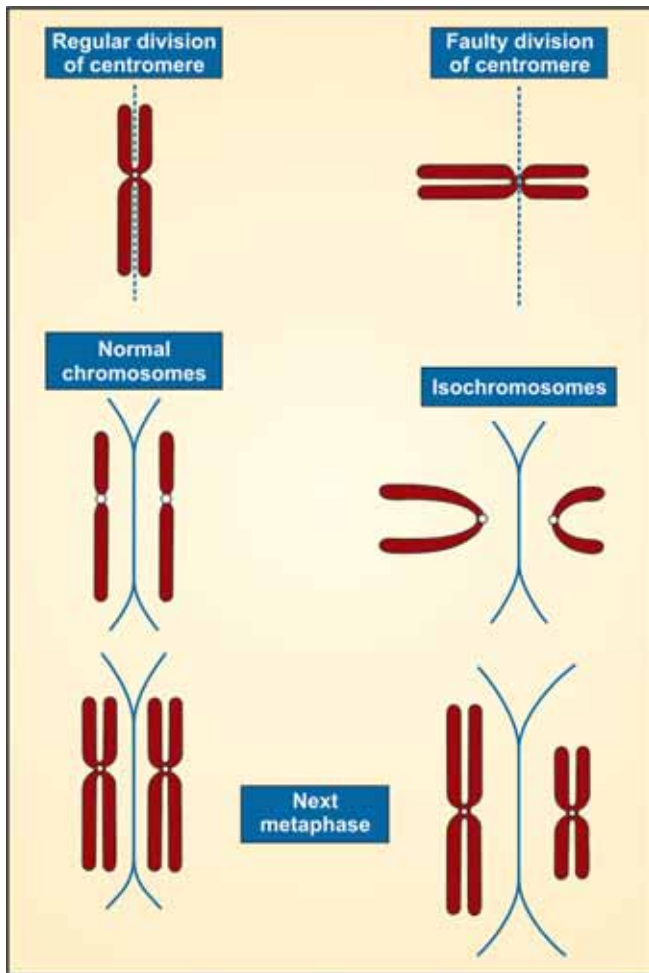
**Fig. 14.3:** Non-disjunction of the sex chromosomes of the ovum at the time of reduction division. After fertilisation the possible combinations of sex chromosomes are XXX (triple X syndrome); XO (gonadal dysgenesis or Turner syndrome); XXY (primary microorchidism or Klinefelter syndrome); and YO which has never been found clinically and may be incompatible with life of the embryo. Although probably much less common, non-disjunction can affect the spermatozoon instead of the ovum, the possible results after fertilization being XXY and XO patterns

phenomenon is termed *non-disjunction*; this is not uncommon, especially during the first meiotic (reduction) division leading to the formation of a mature ovum or spermatozoon. The result is an oocyte which may contain either two X chromosomes or no sex chromosome at all, and a spermatozoon with either XY or no sex chromosomes. When fertilisation takes place, the outcomes that are possible are zygotes whose chromosome make-up is 45, XO, 45, YO, 47,XXX and 47,XXY. An embryo with a chromosome pattern of 45,YO has never been found. This, it is assumed, is because such an arrangement is incompatible with the life of a cell or an early embryo (Fig. 14.3).

During mitotic division of the fertilised ovum, errors in the distribution of the chromosomes, even if their original complement is normal, can still occur. Non-disjunction is again possible or, if cleavage takes place, all the resulting products can pass to one daughter nucleus to give it a 48,XXXX or 48,XXYY complement. This is known as *duplication*.

Sometimes in the course of cell division, all or part of a chromosome may be lost (by *anaphase lag*, *depletion* or *fragmentation*). One or two of the arms of an X, for example, may disappear or, on the other hand, become displaced and link with an autosome (*translocation*). Even translocation of part of a Y to an X chromosome, the so-called *X-Y interchange*, is described. Another possibility is for chromosomes to divide across their centromeres





**Fig. 14.4:** This diagram illustrates the abnormal division of chromosomes, across their centromeres instead of longitudinally, to produce isochromosomes

instead of longitudinally to produce *isochromosomes* (Fig. 14.4). Examples of end results of this happening are long-armed X and short-armed X isochromosomes.

Errors of these kinds, affecting only one or two cells at a very early stage of segmentation of the ovum, are reproduced in their offspring and the final outcome is two or more cell lines in the fetus. These can be found throughout the whole body or each may be localized or dominant in particular tissues. This phenomenon is called *mosaicism* and the affected individual a *mosaic*. How far mosaicism is present in all men and women is unknown but, in minor degrees, it may be universal. Mosaicism of a gross degree is not uncommonly found in men and women suffering from aberrations in sex

differentiation and reproductive function (Fig. 14.10). The possible combinations are endless. A few examples are 46,XX/45,XO; 46,XY/45,XO; 46,XX/46,Xx; 46,XX/45,Xf (f meaning a fragment); and 46,XY/47,XXY. The effects on the genital apparatus and phenotype depend on the relative numbers of the different types of cells, that is, on which cell line is dominant, and on their tissue distribution. Thus, if the primitive gonad is predominantly 45,XO it is not likely to develop or function even though most other tissues in the body are 46,XX; if it is 46,XY it will become a testis despite the fact that elsewhere the dominant cell line is 45,XO. The earlier in embryogenesis that any of the abnormalities in the sex chromosome pattern arise, the more widespread and serious is their effect. Three to four per 1000 live babies are born with clearly recognisable sex chromosome aberrations. This, however, understates the incidence since many affected fetuses, especially those with XO patterns, are aborted.

### Chimaerism and Dispermy

The one type of mosaicism which is difficult to understand is the rare combination of XY/XX. This is said to arise under two circumstances. If binovular twins of different sexes have placentas with vascular connections, their bloods intermingle to result in each having leucocytes some of which are XY and some XX. This is the condition of *chimaerism*. When a singleton foetus shows XY/XX mosaicism, the probability is that the ovum was fertilised by at least two spermatozoa (*dispermy*), one carrying an X and one a Y chromosome. Double fertilisation of a two-nucleated ovum and fusion of two zygotes are also postulated happenings.

### Sex Chromatin Pattern

The number of X chromosomes in the nuclei of various cells can be judged roughly by the sex chromatin pattern. This can be studied in all tissues but clinically those most readily available for examination are the epithelial cells (obtained by buccal smear or skin biopsy) and leucocytes.

When more than one X chromosome is present, the nucleus has an additional deposit of chromatin. In epithelial cells this is disposed eccentrically and is called the *Barr body* after its discoverer (Fig. 14.5). In neutrophils it appears as a 'drum stick' appendage to one of the lobes of the nucleus. This chromatin mass is found whenever two or more X chromosomes are present in the nucleus



**Fig. 14.5:** The nuclei of two epithelial cells whose cytoplasm has been removed. Each contains the darkly staining peripheral deposit of nuclear material (the Barr body), which denotes that they are chromatin-positive. This is a feature of nuclei carrying two or more X chromosomes, the satellite chromatin being the inactivated X

and irrespective of the Y complement. A cell which carries it is said to be chromatin-positive; one which does not is chromatin-negative. So the normal female cell (46,XX) is chromatin-positive, and the normal male cell (46,XY) is chromatin-negative. A cell with only one X chromosome (45,XO) is chromatin-negative; one with 47,XXY is chromatin-positive. One with 47,XXX or 48,XXXXY chromosomes is strongly positive since the eccentric masses vary in size or number according to the X complement. This is because only one of the X chromosomes normally plays an active role in the nuclear direction of cell function. The extra chromatin mass represents the X chromosome(s) which is discarded or inactivated, and this happens from about the twelfth day of intrauterine life onwards.

This process of inactivation is called '*lyonisation*' of the X chromosome after its discoverer, Dr Lyon. The X chromosome which is lyonised may have come originally from either gamete. So, in women, it may be presumed on statistical grounds that the nuclei of half the tissue cells are motivated by an X chromosome of paternal origin and half by one of maternal origin. In men, the active X chromosome is always a maternal one.

The Barr body first appears in trophoblast cells at about the twelfth day, and in the tissues of the foetus itself by the eighteenth day. The percentage of cells in which the Barr body is *recognised* microscopically varies with the preparation and the observer. A figure between 15 and 50 per cent is accepted for epithelial cells in the female; for leucocytes it may be only 20 per cent. The situation is further complicated in mosaics.

Today, chromosomal culture is widely available and karyotyping has become the method of choice. Tissue cultures of leucocytes or skin epithelial cells are prepared by the addition of a mitogenic agent, i.e. phytohaemag-

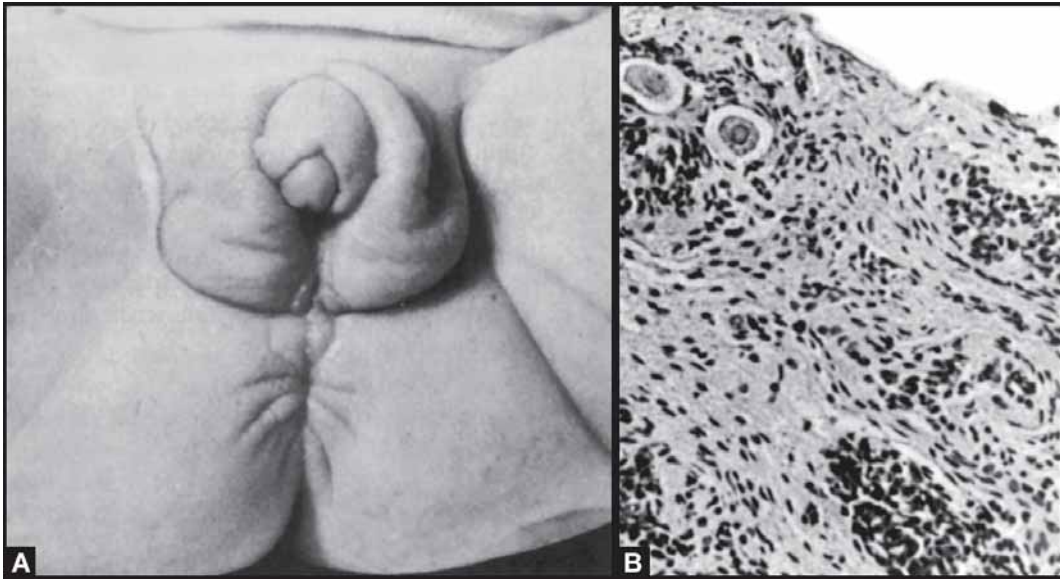
glutinin. They are subsequently arrested at the metaphase by the addition of colchicine. A number of banding techniques are used to stain and identify the separate chromosomes. Of these, G-banding is the commonest. DNA probes prepared for individual chromosomes or for chromosomal regions can be used to identify particular chromosome arrangements or an abnormal number of chromosomes.

### The Chromosomal Sex Drive

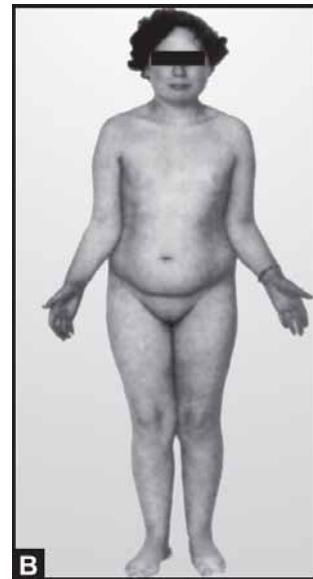
The Y chromosome gives the all-powerful and positive drive towards sex differentiation and, in particular, determines the nature of the gonad. The testis-determining gene, the sex-determining region Y (SRY), is located on the distal short arm of the Y. It is a single-copy gene expressed only at the time of development of the testicular cords, which is instrumental in the expression of the testis-determining factor (TDF). The foetal testes produce the anti-müllerian hormone (AMH) and testosterone. The development of an ovary depends not so much on an XX chromosome complement but on the absence of the Y and the consequent absence of AMH. A few isolated cases of individuals without a Y sex chromosome yet possessing testes are described (the XX male). The finding is explained by an X-Y interchange which results in fertilisation of the ovum by an X spermatozoon carrying the TDF gene on the SRY to give rise to an XX<sup>Y</sup> individual. In such a case, lyonisation of the X to leave the X<sup>Y</sup> active might result in the development of testes. Conversely, XY females are described in whom the absence of the TDF results in the development of an XY female. These sex-reversal disorders are seen in approximately 1 in 20000 births. The Y chromosome is also a positive masculinising force in other ways. Irrespective of the total sex chromosome complement, the presence of a Y usually means that the general physical characters of an individual (*phenotype*) are male. TDF may also play a role in spermatogenesis in the adult.

### Ovotestis

When the chromosomal direction to the gonad is confused, as it may be in certain states of mosaicism, a possible result is the development of both testicular and ovarian tissue, these being either separate (Fig. 14.14) or in the form of an ovotestis (Figs 14.6A and B). This is the condition of so-called true hermaphroditism. Affected



**Fig. 14.6:** A condition of ovotestis in a child aged 3 weeks who, despite the male appearance of the external genitalia, was registered as female. At operation for bilateral inguinal hernias she was found to have a normal uterus and tubes, and gonads in the position of ovaries. Sex-chromatin positive, the chromosome pattern was not determined but was assumed to be XX at the time; mosaicism now seems possible (Miss Isabella Forshall's case), (A) External genitalia showing enlargement of the phallus and hypospadias; the presence or absence of a vagina was not determined, (B) Section of one of the gonads showing two ova to the left of the field and, in other areas, groups of Sertoli cells attempting to form testicular tubules



**Figs 14.7A and B:** Turner syndrome with presumed streak gonads. The patient, aged 17 years, complained of primary amenorrhoea. Height 130 cm. Chromatin-negative; sex chromosome complement not determined. Note the short wide neck, barrel-shaped trunk, increased carrying angle, deformities of the toes and the absence of secondary sex characters



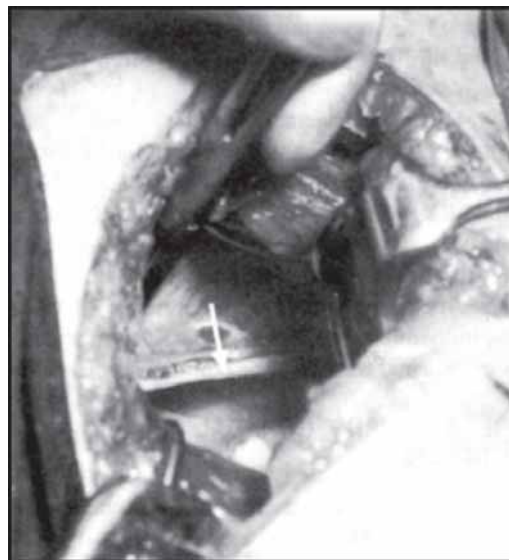
**Fig. 14.8:** Turner syndrome. Girl aged 7 showing webbing of the neck and exaggerated epicanthic folds. She also had a congenital abnormality of the heart. Buccal smears chromatin-negative. Sex chromosomes 45,XO

individuals may be phenotypically male or female. If the former, they often have gynaecomastia in later life, and if the latter they often manifest virilism.

The chromosome patterns in true hermaphrodites, as judged from cultures of epithelial cells and leucocytes, are said to be 60 per cent 46,XX, 20 per cent 46,XY and 20 per cent mosaics and chimaeras. It nevertheless seems likely that the testicular tissue cells must always have some part of a Y component. Indeed, if both gonads contain dominant 46,XY cell lines, individuals with a 46,XY/46,XX karyotype may possess normal testes and be completely masculine.

### Streak Gonads, Gonadal Aplasia and Hypoplasia

When the chromosomal drive to the gonad is weak, hypoplasia of the gonad is likely. Thus, if the Y chromosome is defective, the result may be undescended or poorly developed testes. When the Y is absent, the result is usually the formation of an ovary but only if two complete X chromosomes are present. So, individuals with a 45,XO complement usually show failure of gonadal development - *streak gonads*. The condition of streak gonad is often referred to as *gonadal dysgenesis (ovarian agenesis* in the past) but this term strictly means any disturbance in the development of the gonad. *Gonadal agenesis* or aplasia are preferable



**Fig. 14.9:** The 'streak' gonad (white arrow), formerly regarded as typical of Turner syndrome but now known to be a possible result of a variety of sex chromosome aberrations. This photograph was taken at laparotomy on a girl aged 17 years complaining of primary amenorrhoea and absence of secondary sex characters. The vagina, uterus and tubes were present in an infantile state. The patient was 165 cm in height and showed none of the stigmata of Turner syndrome. The sex chromosomes, in leucocytes, skin and gonadal tissue, were XY and the buccal smear chromatin-negative

names despite the chosen descriptive label. For the gonad concerned is represented by nothing more than a strand of white undifferentiated connective or stromal tissue lying on the back of the broad ligament, the internal genitalia being always female (Fig. 14.9).

The embryological history of the streak gonad is as follows. Initially primordial germ cells appear in the genital ridge in the normal way but, although some may persist up to the fourteenth week of intrauterine life, they all die quickly. They are therefore unable to organise or maintain other tissue elements in the gonad, which becomes little more than fibrous tissue. Very occasionally the picture is incomplete and a few ova are found in the ovary at birth but these disappear in childhood or adolescence.

### SEX CHROMOSOMAL INTERSEX

#### Turner Syndrome (First described in 1957 by Henry Turner)

This is the classical syndrome associated with streak gonads, and the underlying error is a karyotype of 45,

XO or a mosaic containing this cell line. The primary cause is non-disjunction of the sex chromosomes as described on page 222, the single X chromosome being maternal in origin in 75-79 per cent of cases. Many of the 45, XO embryos are aborted but those that are not become malformed and, in addition to having streak gonads, present the features of Turner syndrome at and after birth. Being without a Y chromosome, all affected individuals appear female and their incidence is 0.2 per 1000 live girl babies. The diagnosis can often be made in infancy, being prompted by somatic defects listed below:

### Characteristic

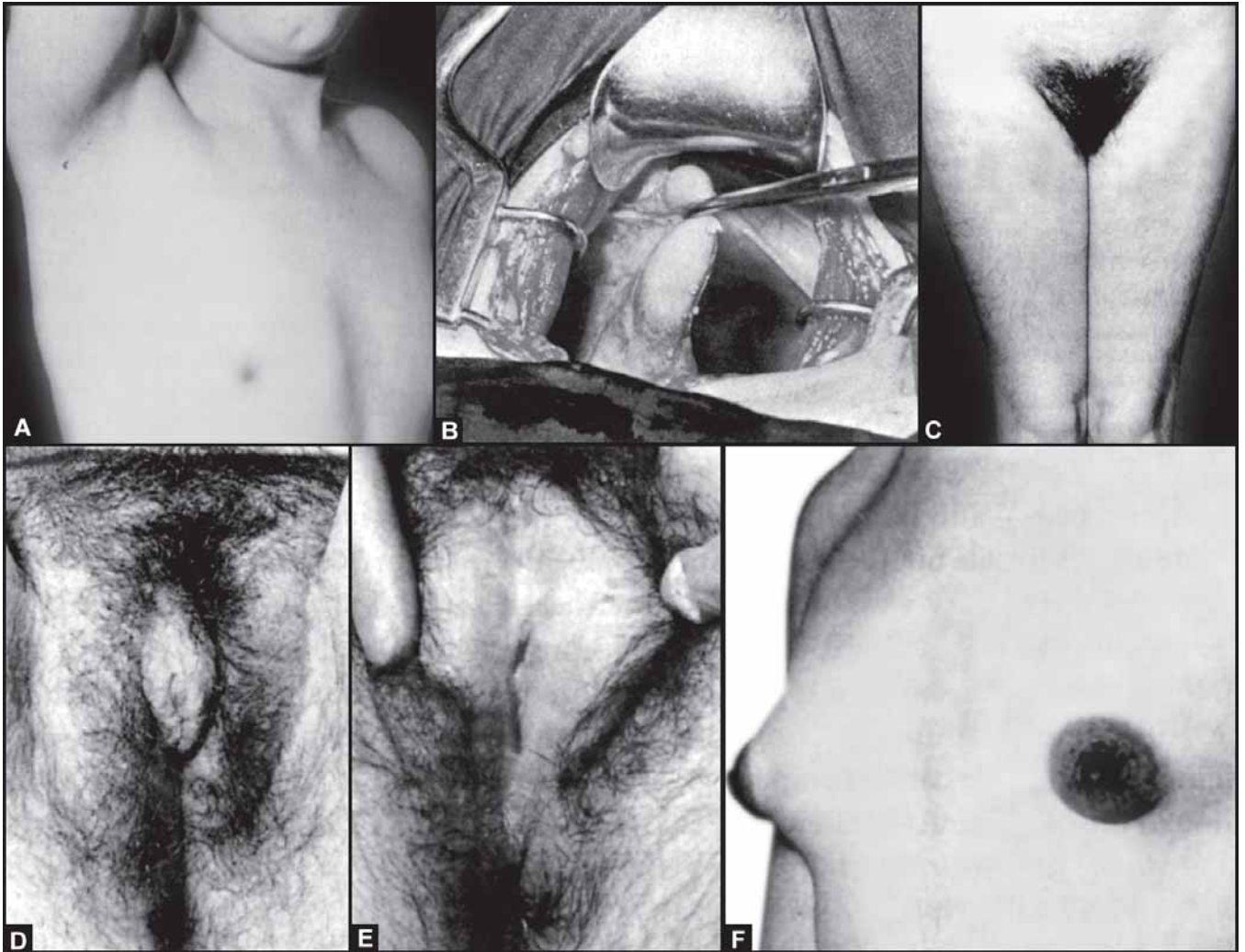
1. Short slender female less than 5 ft. (150 cm)
2. Height span ratio altered
3. Secondary sexual ratio altered
4. Breast B<sub>0</sub> or B<sub>1</sub> (tanner classification)
5. Body hairs absent
6. Shield chest, webbing of neck, cubitus valgus (90% show skeletal abnormality)
7. Cardiovascular abnormalities (aortic stenosis, coarctation of aorta 30-40%)
8. Urinary abnormalities (50-60%)
9. Mental retardation (15%)
10. External genitalia poorly developed.
11. Uterus and tubes-hypoplastic
12. Internal gonads-agenetic or dysgenetic
13. Chromosomal pattern 45XO
14. Case of chromosomal deletion
15. Extra X chromosome in females usually does not affect physical development or fertility. Absence of sex chromosome is serious.
16. Primary ovarian failure
17. Germ cells are present in the embryonic gonads but usually disappear or are severely depleted at birth.
18. Mosaicism in 45X patients may occur (46XX/45XO)
19. Colour blindness and multiple navi on skin
20. Autoimmune disorders such as Hashimoto's thyroiditis, Addison's disease and vitiligo are common
21. In newborn babies with Turner's these may be chronic nuchal oedema as well as other stigmata of the nuchal cystic hygroma syndrome.
22. Newborns may have life threatening effusions in serous cavities.
23. Abnormality of lymphatic system may sometimes cause gross swelling of the legs in the child or adult.

### Other Syndromes and Karyotypes Associated with Streak Gonads

The genes which protect against the physical malformations of Turner syndrome are carried on the short arms of two matching chromosomes - XX or XY; those which protect against streak gonads are on the long arms. If only the short arms of an X or Y are missing, the effect can be to produce some or all of the stigmata of Turner syndrome without failure of gonadal and genital development in either a male or female direction. Conversely, if the short arms of a second X, or Y, are present, even in fragmentary form, the woman with streak gonads may be of normal height and free from other physical extragenital defects. This can happen when the karyotype is 46,XXf and 46,XX/45,XO. Incidentally, the possibility of a mosaic background, and sometimes even an XX one, explains why 20 per cent of women showing a fairly typical Turner syndrome have chromatin-positive buccal smears, hence the importance of doing a complete karyotype if possible.

For the above reasons, streak gonads can be found when the karyotype is 46,XY or 45,XO/46,XY; in such cases the patients tend to be tall and eunuchoid in build. The genitalia are always female but the 'woman' may develop a degree of virilism by way of slight enlargement of the phallus and hirsutism. It comes about therefore that all variants between a typical Turner syndrome and something approaching a normal male or female phenotype can accompany streak gonads, although the genital tract is essentially female. In *Noonan syndrome (male Turner syndrome)*, streak gonads go with a 46,XY karyotype. The somatic defects resemble many of those of Turner syndrome but the characteristic cardiac lesion is stenosis of the pulmonary valve. Those affected are also likely to have mental retardation and develop autoimmune thyroiditis. These patients are fertile and the trait is transmitted as an autosomal dominant one with variable expression.

The situation is further complicated by the fact that 46,XX/45,XO mosaicism can, rarely, result in a functional ovary on one side and a streak gonad on the other and thus a menstruating woman with the physical stigmata of Turner syndrome. Rarely, such women can have a pregnancy also, but there is a high risk of congenital abnormalities in the offspring, including Down syndrome, spina bifida and congenital heart disease, so prenatal testing is mandatory. More commonly, a streak gonad on one side is accompanied by a testis (in the



**Figs 14.10A to F:** Unilateral streak gonad and unilateral cryptorchidism. An apparent girl of unusual facial beauty, aged 16 years, complaining of primary amenorrhoea and deepening of the voice. Height 155 cm; chromosomes 45,XO/46,XY/47,XYY. The vagina, uterus and tubes were present, with a testis on the back of the left broad ligament and a streak gonad on the right, (A) Axillary hair present, breasts undeveloped. The 'cleft' chin was the only masculine feature of the facies. (B) The left gonad as seen at laparotomy is typical of an undescended testis. (C) Pubic hair normal; the thighs are slightly hairy but this apart there was no hirsutism. (D) An enlarged phallus obscuring an otherwise female introitus. (E) The appearance of the vulva after removal of the phallus (today we would prefer clitoroplasty to clitoridectomy). (F) Breasts beginning to develop as a result of oestrogen therapy instituted after removal of the gonads. This treatment also induced cyclical uterine bleeding

position of the ovary) on the other (Figs 14.10A to F). The background for this is mosaicism such as 46,XY/45,XO. Again, the ducts are almost invariably müllerian.

Streak and dysgenetic gonads have a high potential for neoplasia if the owner's karyotype contains a Y

chromosome. In such cases, the risk of a tumour, such as a disgerminoma or gonadoblastoma, developing in later life is put at 20-30 per cent. Unless a Y chromosome is in the background, however, streak gonads carry a negligible risk in this respect.

### Triple X Syndrome (47,XXX)

One per 1000-1200 women have a 47,XXX chromosome make-up, this being mostly the result of non-disjunction during oogenesis (Fig. 14.3) i.e. X sperm fertilising XX ovum. These were originally described as *super females* which they are not, for they are likely to suffer from oligomenorrhoea, secondary amenorrhoea, infertility, genital tract hypoplasia and premature menopause. Other features of the triple-X syndrome are low intelligence, sometimes gross mental deficiency or psychosis, and often abnormal EEG patterns and presence of two Barr bodies.

Nevertheless, the majority of women with a 47,XXX karyotype appear to be normal in every way and are fertile. Moreover, the taint is not transmitted to their offspring, the extra X being lost during oogenesis, even though there is a theoretical risk of XXX or XXY.

### Primary Micro-orchidism: Klinefelter Syndrome (47,XXY)

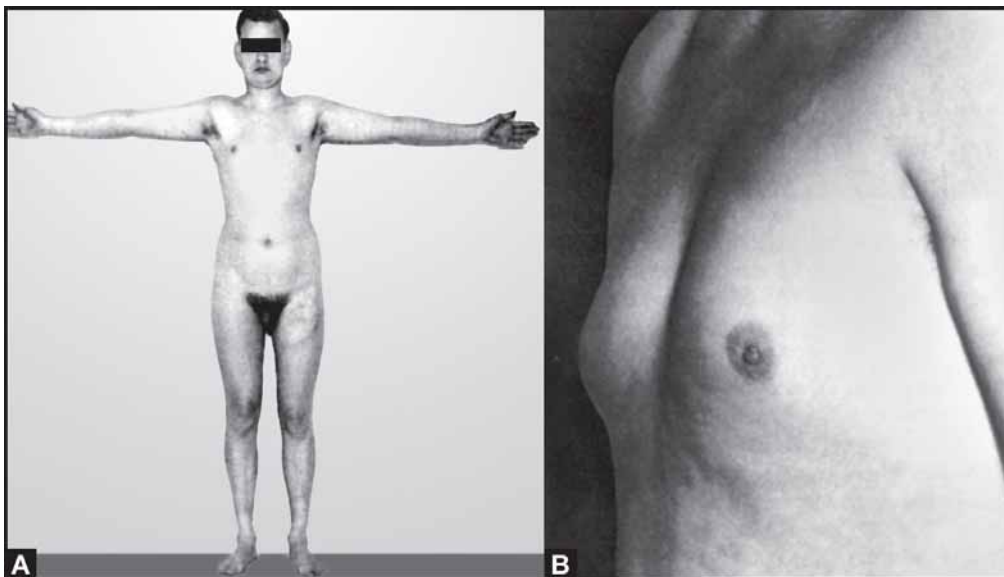
The 47,XXY karyotype is found only with a male phenotype, its incidence being 1.5-2.0 per 1000 men. It is correctly known as "seminiferous tubule dysgenesis". It usually results from non-disjunction, the additional X chromosome being maternal in 60 per cent of cases (Fig. 14.3). The typical effect is the Klinefelter syndrome which

combines a tall eunuchoid figure with testicular and genital hypoplasia (Figs 14.11A and B). Slender male with female distribution of fat. The testes are very small and may or may not be descended. Their embryological history is rather similar to that of the streak gonad. Germ cells are present in the genital ridge in the embryo but disappear early in foetal life. After birth, the tubules are aplastic and functionless so sterility is the rule. The secretion of gonadotrophins is sometimes increased.

Gynaecomastia develops in the adult in 15 per cent of cases, and there is a much increased risk of carcinoma of the breast in later life. The Klinefelter syndrome is also characterised by mental defects, antisocial behaviour (psychopathic behaviour) and abnormal EEG patterns. So the incidence of the 47,XXY karyotype, if not of the syndrome, amongst inmates of prisons and of institutions dealing with psychiatric disorders is as high as 1-10 per cent.

External genitalia are hypoplastic, phallus small or normal with undescended testes, usually subfertile or infertile but not impotent. Testicular biopsy shows hyalinised seminiferous tubules and hyperplastic leydig cells. Pituitary hormones normal (FSH, LH), adrenal MKS normal and testosterone reduced.

The above is the classical picture, which is also seen with mosaics such as 47,XXY/46,XY. Men with an XXY complement in their chromosome make-up can be



**Figs 14.11A and B:** Klinefelter syndrome. Man aged 28 years, married but infertile and complaining of gynaecomastia. Chromosomes 47,XXY. (Professor Sir Cyril Clarke's case) (A) An apparently normal male but tall. The scrotum is small and contains very hypoplastic testes. (B) Slight enlargement of the breasts

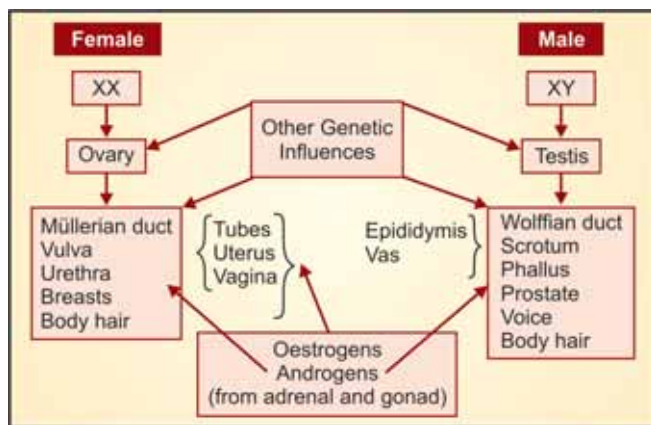
completely normal, physically and mentally, and may even have superior intelligence and drive. Moreover, they can be fertile and produce normal 46,XY and 46,XX offspring, the additional X being lost during the maturation of spermatozoa.

### The YY Syndrome

As a result of errors in nuclear division, such as duplication in the zygote, there are men with two or more Y chromosomes and with karyotypes such as 47, XYY, 48, XYYY and 48, XXYY, and mosaic patterns containing these. Such men often suffer from the 'YY' syndrome which is characterised by excessive tallness, aggressive and antisocial behaviour, and criminal tendencies with or without mental subnormality. Their genital development and fertility are usually normal. The possible aberrations of sex chromosome numbers and types, and their combinations in mosaics are endless, but their effects are always in line with the principles stated above. Thus, a 48, XXXY individual is likely to present as Klinefelter syndrome, as are the mosaics in which the 47, XXY cell line is dominant. A woman with a 48, XXXX karyotype is likely to have the clinical features of the triple-X syndrome.

### Other Genetic Influences

Although relatively weak as compared with those on the sex chromosomes, there are also sex-influencing



**Fig. 14.12:** Diagrammatic representation of factors determining sex *in utero*. These are sex chromosomes, genes on autosomes, organiser influences of the gonad directly on the ducts, and hormones of the foetus. Their sites of operation are indicated by arrows

genes on the autosomes (Fig. 14.12). These, which are mainly masculinising, can modify the chromosomal urge towards sex differentiation, especially if it is weak or if they are strong.

Autosomal genetic masculinising influences in an otherwise normal female probably account for 'constitutional' hirsutism (Fig. 14.13). So it is not surprising that this common syndrome shows a strong familial and inherited tendency. An autosomal genetic influence, operating at an early stage in embryonic development, can also modify the development of the genital tracts, if not the gonad. Thus, malformation deformities of the uterus, and hypospadias in the male, are sometimes familial. The polycystic ovary syndrome is also known to have a familial tendency.

### AUTOSOMAL INTERSEX

#### Constitutional Hirsutism

There is normal development. Gonads are ovaries and are normal, ovulation is present. Because of presence of certain genes on autosomes there may be excessive response of hair follicles to androgens resulting in hirsutism.



**Fig. 14.13:** Hirsutism of constitutional origin. A woman aged 24 years complaining of gross hairiness of the legs, arms, back and face. Yet she menstruated regularly and had well-developed breasts. All hormone assays gave normal findings



### Testicular Feminising Syndrome

The chromosomal sex is XY, the patient is phenotypically female. The gonads are testes. The testes actually secrete oestrogens and cause female secondary sexual characters. Characteristics are:

1. Phenotypic female
2. Female distribution of fat and female voice
3. Good breast development
4. No body hair (hairless female) except scalp
5. External genitalia female but infantile
6. Vagina absent or blind pouch but normal vulva
7. Internal gonads usually undescended testes
8. Uterus and tubes absent (due to MIF from testes)
9. There is an enzymatic block in testicular epithelium so testosterone is not converted to active dihydrotestosterone.
10. There is insensitivity of end organs to androgens (hair follicles, vocal cords and phallus).
11. Treatment is gonadectomy as risk of malignancy is 4% and vaginoplasty for sexual function
12. This syndrome shows a familial tendency, the trait being transmitted maternally.
13. Plasma levels of testosterone and other androgens are above normal range for male due to increased LH. There is associated increase in testicular oestradiol and also there is peripheral conversion of androgens to oestradiol.
14. Incomplete syndrome (Reifenstein syndrome) are also described as partial androgen insensitivity. Management depends on degree of ambiguous genitalia and sex of rearing some men of Reifenstein syndrome may respond to high doses of testosterone for those assigned as females. The treatment is gonadectomy, vaginoplasty and HRT.
15. A third form of androgen insensitivity is  $5\alpha$  reductase deficiency. Testosterone is not converted to dihydrotestosterone (DHT) at target tissues.

### GONADAL INTERSEX

Gonadal intersex is of three types:

1. True hermaphroditism
2. Male hermaphroditism
3. Female hermaphroditism

- a. Mostly are 46 XX with chromatin positive but may be 46 XY
  - b. Gonads are both ovaries and testes either ovary one side and testes other side or ovotestes on both sides.
  - c. Phenotypic growth is feminine
  - d. *External genitalia may be ambiguous*: perioclitoris or incomplete labioscrotal folds
  - e. Familial cases are autosomal recessive, autosomal dominant is rare.
2. Male Hermaphroditism
    - a. Chromatin negative i.e. 46 XY
    - b. External genitalia are masculine but there is presence of müllarian tissue
    - c. Normal development, normal puberty and fertility
    - d. Usually detected during hernia surgery. When müllerian tissue is present (lack of MIF)
    - e. Condition is rare.
  3. Female hermaphroditism
    - a. Relatively common
    - b. External genitalia show perioclitoris, incomplete fusion of labioscrotal folds, single urogenital opening
    - c. Gonads are usually testes, have normal testicular tissue but no spermatogenesis
    - d. Testes fail to have proper influence through morphogenetic hormone, hence reared as females.

### The Organising Power of the Gonad

Irrespective of chromosomal and genetic drives, sex differentiation *in utero* is partly controlled by the organising power of the gonad. The development of the gonad itself is dependent on the presence of the primitive germ cells which determine whether the gonadal mesoderm shall differentiate into granulosa cells or testicular tubules. Without these germ cells, as in Turner syndrome, the gonad remains asexual. The gonad in turn controls the persistence or degeneration of the müllerian and wolffian ducts but, in this respect, it is the testis which is all-important. Unless functional testicular tissue is present in the foetus, the müllerian ducts invariably persist to give rise to a female genital tract, irrespective of the sex chromosome complement. This is because the foetal testis secretes AMH, which is a polypeptide produced by the Sertoli cells.

When half the genital tract is male and half female, it is the presence of a testis rather than the absence of an ovary which accounts for the vas and epididymis on that side. Moreover, it is the absence of the testis rather than the presence of the ovary on the other side which allows the corresponding müllerian duct to persist and the wolffian duct to atrophy (Fig. 14.14).

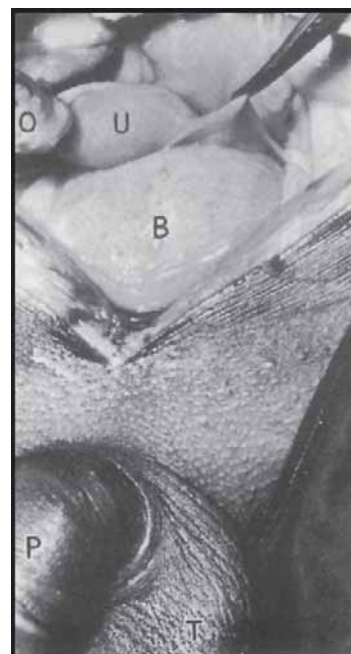
Occasionally, a fertile man, with either one or both testes normal, is found to house a complete uterus and fallopian tubes. The explanation of this is that during early foetal life, his testes failed to produce AMH, even though they functioned properly after birth (Fig. 14.15).

### HORMONAL INTERSEX

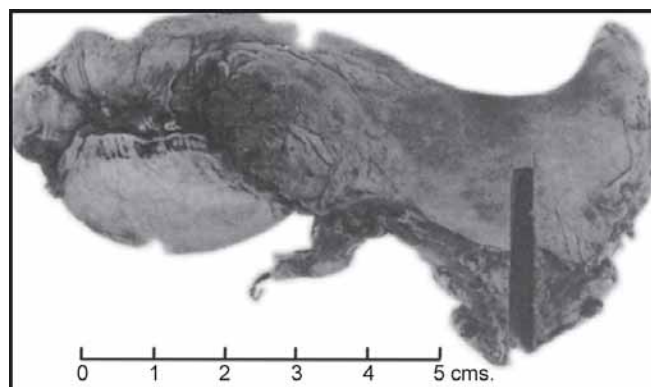
The steroid hormones cross the placenta and it is somewhat surprising that the large amounts of oestrogen and progesterone in circulation during pregnancy do not influence sex differentiation in the foetus. If, however, the mother suffers from an androgenic tumour of the ovary (e.g. luteoma, androblastoma, mucinous cystadenoma or Kruken-burg's tumours), adrenal (e.g. adenoma), or if she takes exogenous androgens, the genitalia of the female foetus become virilised. The degree and type of virilisation depend on the timing and strength of the hormone influence but, since there is no müllerian inhibitor, the tubes, uterus and vagina develop normally. The effects are seen only in the external genitalia and consist of enlargement of the clitoris, with or without fusion of the labia minora as seen in congenital adrenal hyperplasia (*see below*). To produce gross deformity the androgenic impulse must be applied before the fourteenth week.

Progesterone is weakly androgenic and synthetic progestogens, especially ethisterone and norethisterone, can, when given to the mother, sometimes virilise the female foetus. It is remarkable how few girl babies have been reported to have had masculinised external genitalia considering the large numbers of mothers who, in the past, were treated with progestogens for threatened and recurrent abortion. In explanation it is suggested that virilisation only occurs when the metabolism of the mother or her foetus is such as to convert progestogens to androgens.

Sex differentiation of the external genitalia is normally strongly directed by the hormones which the foetal adrenals and gonads produce. The androgenic influence is especially important. The adrenal cortex of the foetus



**Fig. 14.14:** Influence of the gonad on development of the genital ducts. An adult African man with a normal phallus (P) and scrotum but only the left testis (T) descended. Within the abdomen and behind the bladder (B) is a right-sided unicornuate uterus (U) with a tube and ovary (O). The ovary contains a recent corpus luteum. It is the absence of a testis on the right side which explains the persistence of the müllerian duct on that side. The buccal smears were chromatin-positive but the chromosomal pattern was not determined. It might have been 46,XX/46,XY. This case of so-called true hermaphroditism was in the care of the late Dr N.de la Harpe of Pretoria



**Fig. 14.15:** A uterus and fallopian tube, the former containing histologically typical endometrium, removed from the hernial sac of a man aged 31 years and the father of 2 children. The gonad in the specimen is a hypoplastic testis with its vas in the position of Gärtner's duct. This man had a normal testis (and a fallopian tube) on the other side and good function of this testis was shown by semen analysis (Mr Donald Young's case)

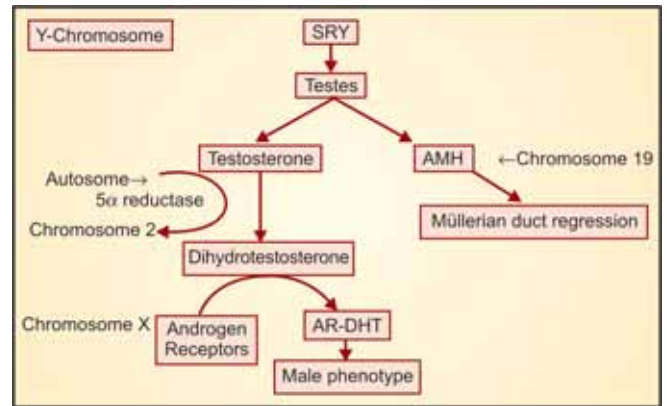
is active by the twelfth to sixteenth week and an abnormality in its function can cause a state of intersex (Flow chart 14.3).

### Congenital Adrenal Hyperplasia

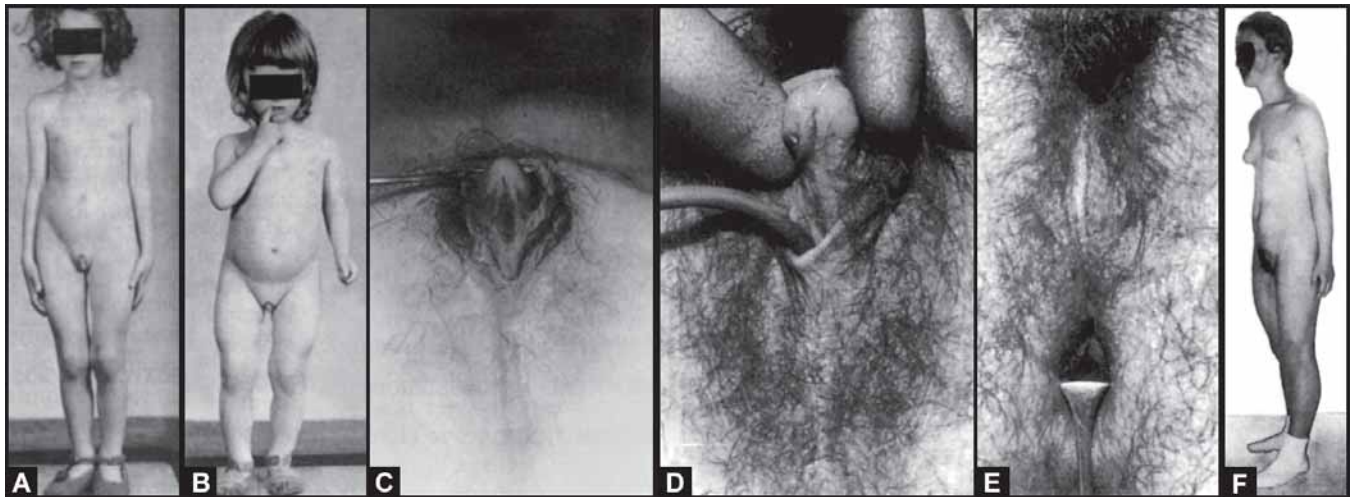
This is a familial disease transmitted by a recessive gene. If any couple has had one affected child, a subsequent baby has a 1 in 4 chance of having the same disability (Figs 14.16A to F). The cause of the disease is an inherent enzymatic error in the adrenal cortex, which is unable to complete the normal biosynthesis whereby progesterone is converted through hydroxyprogesterone to cortisol. There are several levels at which arrest can occur, with consequent variations in the effects. The most common enzymatic defects are those of 21-hydroxylase, 11  $\beta$ -hydroxylase and 3  $\beta$ -hydroxysteroid dehydrogenase.

Typically, however, the metabolic chain is broken at the hydroxyprogesterone stage, i.e. 21-hydroxylase deficiency (Figs 14.17A and B). The resulting deficiency of corticoids means that the output of ACTH by the pituitary is not controlled. The excessive production of ACTH causes bilateral adrenal hyperplasia and an increased secretion of nearly all adrenal cortical

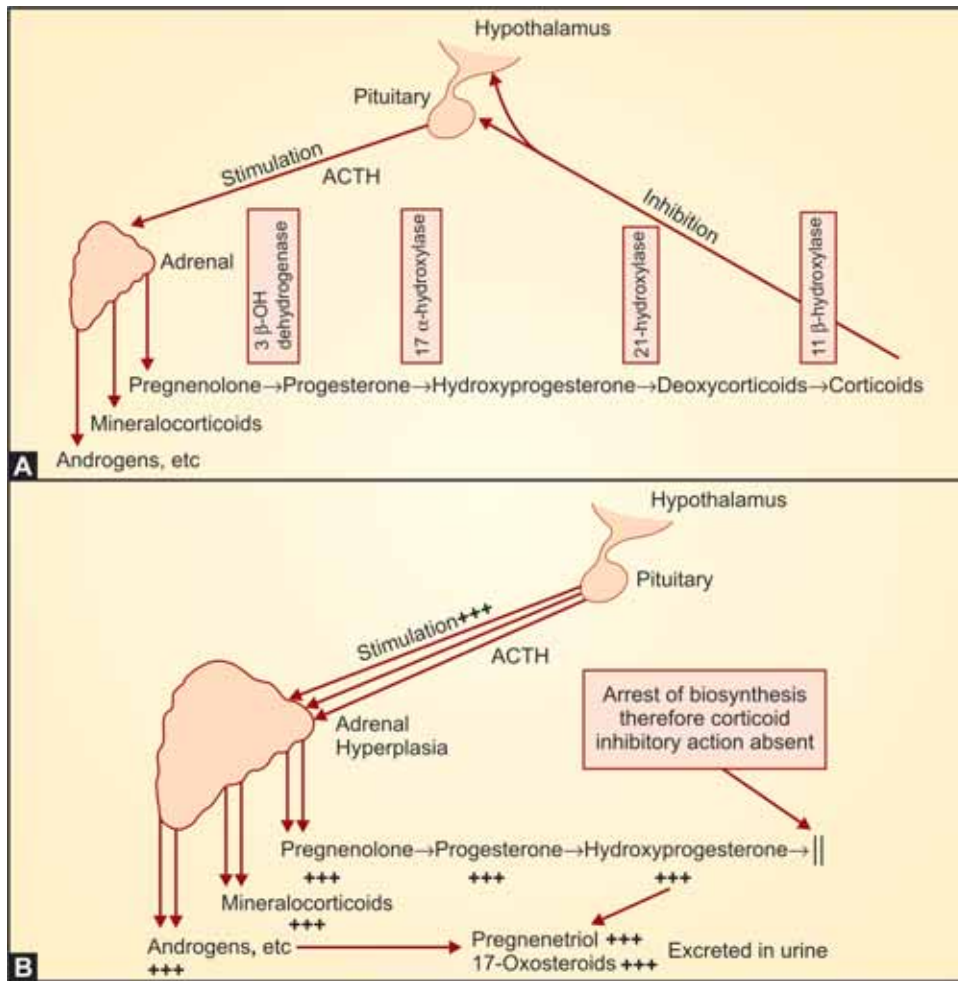
Flow chart 14.3: Hormonal pathway



hormones. These include androgens so, in the female foetus, sex differentiation of the external genitalia is disturbed. The ovaries, tubes, uterus and vagina are basically unaffected because their development is not subservient to androgens but the vulva and introitus are affected. The genital folds fuse in an attempt to form a penile urethra instead of labia minora, and the phallus enlarges so the infant at birth appears to be a male with hypospadias (Fig. 14.16C). Distinction between the two conditions, at one time difficult, is now easy. Girls



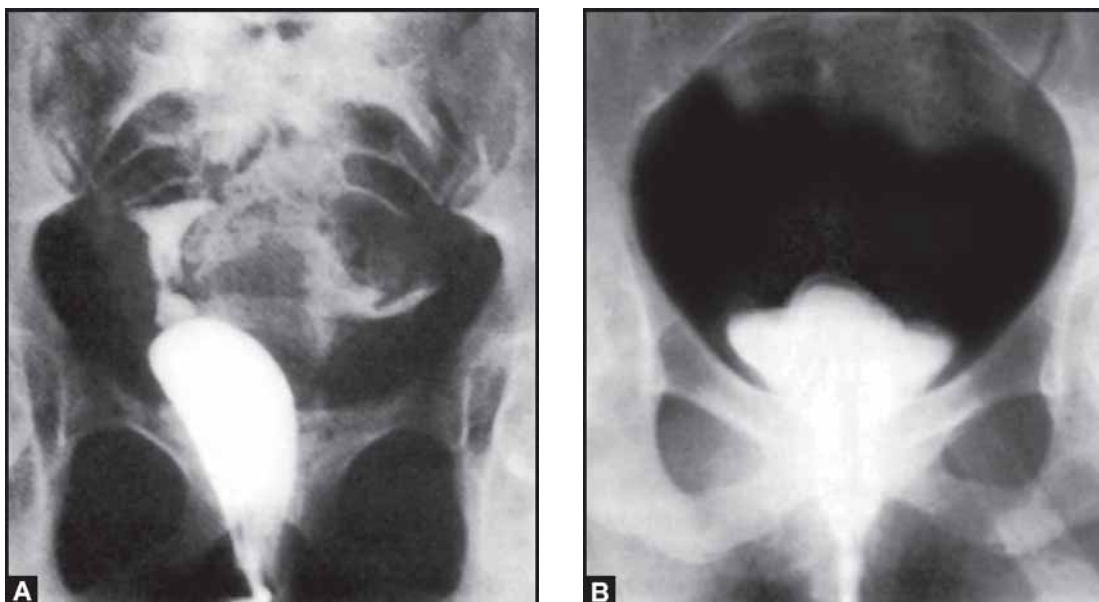
**Figs 14.16A to F:** Sisters each exhibiting congenital adrenal hyperplasia. Another child of the same parents had been born earlier and registered as a male. It died when 6 weeks old from 'wasting'; so it was probably affected and died from electrolyte imbalance, (A) The older girl aged 4½ years, physically and sexually precocious. Axillary and pubic hair present and voice breaking. Excretion of 17 ketosteroids = 25 mg/24 hours, (B) Younger child aged 2½ years and also precocious. 17-ketosteroid excretion = 15 mg/24 hours, (C) The external genitalia were identical in appearance and this shows the finding in the child aged 2½ years. The uterus, tubes and ovaries were normal in both, (D) The external genitalia at the age of 10 years; the catheter is inserted for the purposes of a vaginogram. (E) The external genitalia 3 months after a reconstruction operation at the age of 10 years, (F) Breast development, previously absent, after 1 year's treatment with prednisolone. Regular menstruation had also resulted from this treatment. Both girls responded equally well



**Figs 14.17A and B:** (A) Normal relations between the hypothalamic-pituitary system and the adrenal cortex. Corticosteroids are synthesized in the adrenal from pregnenolone and these in turn control the secretion of ACTH by the pituitary. A balance is thus maintained, (B) The relations between the hypothalamic-pituitary system and the adrenal cortex in congenital adrenal hyperplasia. Synthesis of corticoids by the adrenal is blocked, usually at the hydroxyprogesterone link in the chain. The excretion product of this substance, pregnanetriol, therefore appears in large amounts in the urine and liquor amnii. Absence of the corticoid inhibitory effect on the hypothalamus and pituitary allows an excessive output of ACTH and consequent overstimulation of the adrenal cortex. The result is increased blood levels and secretion of androgens and sometimes other products, and a rise in the urinary excretion of 17-ketosteroids

suffering from congenital adrenal hyperplasia are always sex chromatin-positive, and have a 46,XX chromosome pattern. The serum levels of 17-hydroxyprogesterone (17 OHP) are elevated. (Correspondingly, urine levels of 17-ketosteroids and of pregnanetriol are also elevated). The anatomy can be confirmed by instilling a radio-opaque medium into what appears to be the urethra to demonstrate the presence of the vagina within (Figs 14.18A and B).

After birth the fundamental metabolic upset continues, so the excessive adrenal cortical function causes physical and sexual precocity which, in the female child, is of the virile pattern (Figs 14.16A to F). Pubic and axillary hair appear, and the voice deepens by the age of 2-4 years. Affected children at first grow quickly but the epiphyses of their long bones close at the age of 8 or 9 years. They thus first outstrip and later lag behind their contemporaries in height. The ovaries, although



**Figs 14.18A and B:** Congenital adrenal hyperplasia. Vaginograms obtained by running in radio-opaque fluid through a catheter inserted as in Fig. 14.16(D), the head of the patient being slightly lowered, (A) In this case the fluid not only filled the obscured vagina but ran into the uterus and even into the peritoneal cavity. Girl aged 11 years, (B) Here the fluid entered both the urethra and the vagina to produce a cystogram superimposed on a vaginogram. Girl aged 8 years

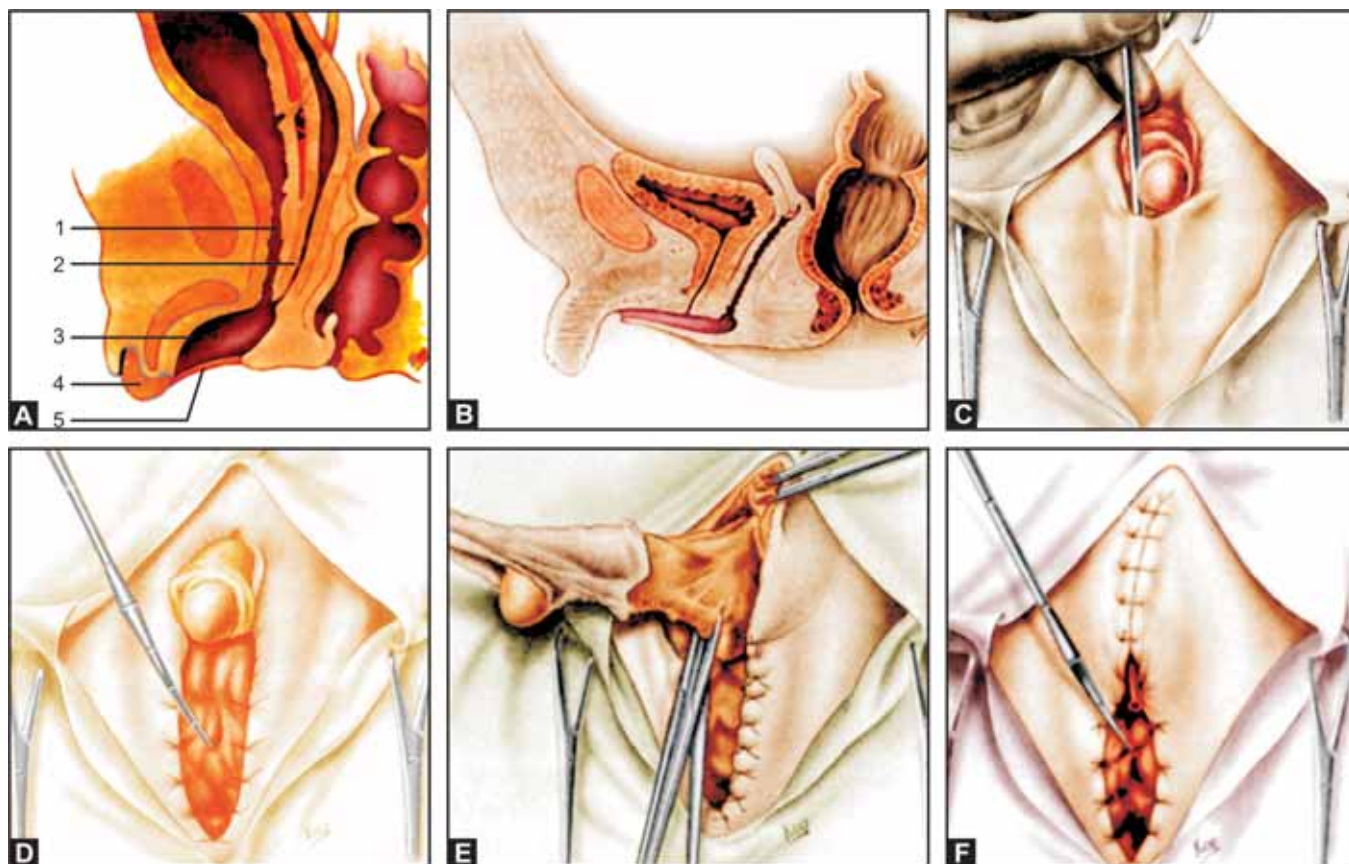
normally formed, do not function; the uterus remains infantile and fails to menstruate; hirsutism becomes a problem. As the years go by masculinity becomes so intense that, in the days when effective treatment was impossible, many sufferers from the congenital adrenal hyperplasia (CAH) found it easier to live as men. In the more severe forms of the disease, salt-wasting and shock may also be present at birth. Very mild, nonclassical disease may present only at puberty. When male foetuses suffer from congenital adrenal hyperplasia, their precocious masculinity is accentuated to produce the 'infant Hercules'.

Provided that the diagnosis is made early, postnatal development can be corrected. Cord blood can be assayed for 17 OHP levels and is the basis for some neonatal screening programmes. It requires only a relatively small dose of one of the corticosteroid preparations, determined by clinical trial and controlled by periodic assays, to inhibit the ACTH output and to allow the function of the reticular layer of the adrenal cortex to return to normal. Treatment has to be continued throughout life but, if properly regulated, is not likely to involve the risks of adrenal suppression. The adrenals are not made inactive; their function is merely reduced to normal.

The abnormality of the vulva can readily be corrected by plastic surgery (Figs 14.16 and 14.19). Exposure of the vagina can be deferred until puberty but, to avoid a psychological reaction, the large phallus should be removed before the age of 5 years. Early diagnosis and treatment are important, otherwise voice changes, persistent hirsutism and premature closure of epiphyses leave permanent stigmata. With steroid therapy, ovarian and uterine functions become normal and fertility is possible. The disorder is transmitted to the offspring as a monogenic autosomal recessive trait. Psychological counselling is required both for the parents and the child.

Deficiency of 11  $\beta$ -hydroxylase is the hypertensive form of CAH. The levels of 11-deoxycorticosterone are raised as a result of the enzyme deficiency and since this has salt-retaining properties, hypertension ensues, although aldosterone levels are reduced. Elevated levels of androstenedione can result in ambiguous genitalia. Diagnosis is made by measuring elevated levels of urinary 17-hydroxycorticosteroids and of serum androstenedione. Treatment is as described above.

Deficiency of 3  $\beta$ -hydroxysteroid dehydrogenase is a rare form of CAH. The block in steroidogenesis occurs very early in the pathway leading to decreased synthesis of gluco- and mineralocorticoids, androgen and



**Figs 14.19A to F:** Correction of the deformity of the external genitalia in congenital adrenal hyperplasia. (A) The normal development of the vulva, vagina and urethra at the fourth month (after Hamilton, Boyd and Mossman). (1) urethra; (2) vagina; (3) vestibule forming from the urogenital sinus; (4) clitoris; (5) site of cloacal (urogenital) membrane, (B) The deformity in the adrenogenital syndrome represents essentially a fusion of the genital folds to form a perineal membrane which obscures the introitus and vagina, (C) The occluding membrane demonstrated, (D) Incision of the membrane reveals the urethra and vagina, (E) Removal of the enlarged clitoris, (F) The ultimate result; compare with Fig. 14.16(E)

oestrogens. A severe salt-losing state ensues which results in electrolyte upsets in the newly born baby. Unless recognised and treated, these cause vomiting, wasting and death within a few days or weeks. The possibility of an abnormal electrolyte balance should always be investigated before any operation on a child suffering from the adrenogenital syndrome. Dehydroepiandrosterone (DHEA) is the androgen most elevated and it causes mild virilisation. Treatment of the salt-losing crisis involves correction of the electrolyte imbalance and replacement with prednisolone, dexamethasone or desoxycorticosterone acetate. The majority of cases require fludrocortisone 0.1-0.2 mg/day in addition to prednisolone or dexamethasone.

In one of Professor Jeffcoate's cases, the finding of excessive amounts of 17-ketosteroids and pregnanetriol in the liquor amnii, contributed by foetal urine, allowed the diagnosis to be made before birth (Fig. 14.20). This original observation has since been confirmed by others. Antenatal screening is indicated when the mother has previously had an affected child. In 21-hydroxylase deficiency, levels of 17 OHP, 21-deoxycortisol and androstenedione in the amniotic fluid are elevated. With 11  $\beta$ -hydroxylase deficiency, 11-deoxycorticosterone is elevated. However, these measurements of amniotic fluid steroids have now been replaced by direct mutational analysis which can detect even mild deficiencies - chorion villus biopsy samples are evaluated



**Fig. 14.20:** The virilised external genitalia of a newborn female suffering from congenital adrenal hyperplasia. This condition was diagnosed before birth because the mother, known to be at special risk of having such a child, was subjected to amniocentesis. Examination of the liquor showed it to contain unusually large amounts of pregnanetriol and of 17-ketosteroids (the latter being less significant). These substances were contributed by the foetal urine. This was the first case in which the diagnosis of any form of foetal metabolic error was made before birth, the possibility having come to mind when it was realised that, since the foetus normally urinates *in utero*, its urine can be examined (via the liquor) before birth. It was this case which led to all subsequent developments in this field

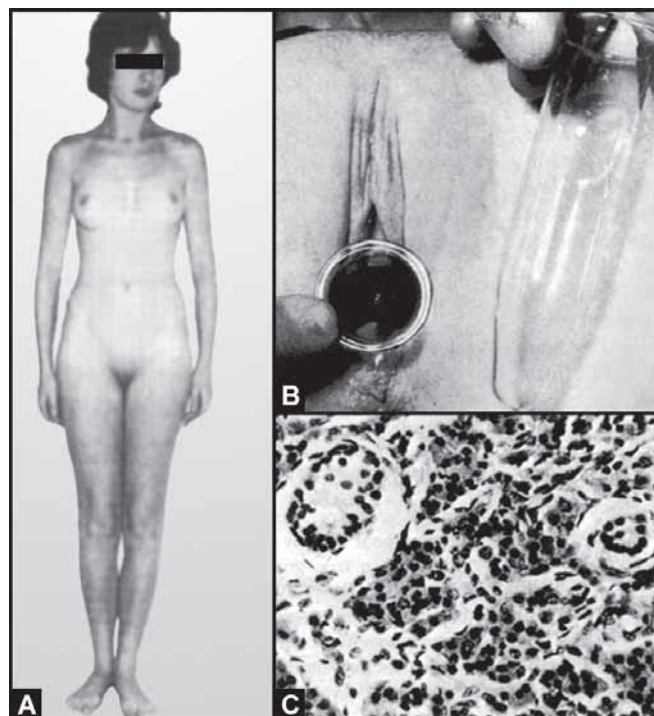
by DNA probes. Therapy with 1.5 mg dexamethasone per day is started at 4-5 weeks' gestation in all women whose foetuses are at risk of 21-hydroxylase deficiency and continued once the deficiency is proved. This prevents the development of ambiguous genitalia in female foetuses and may also have some effect on the foetal brain with regard to gender identity.

#### *Other Causes of Hormonal Intersex*

- Use of androgenic progesterone in pregnancy (intrauterine adrenogenital syndrome)
- Pituitary basophilic adenoma
- Virilising tumours of ovary.

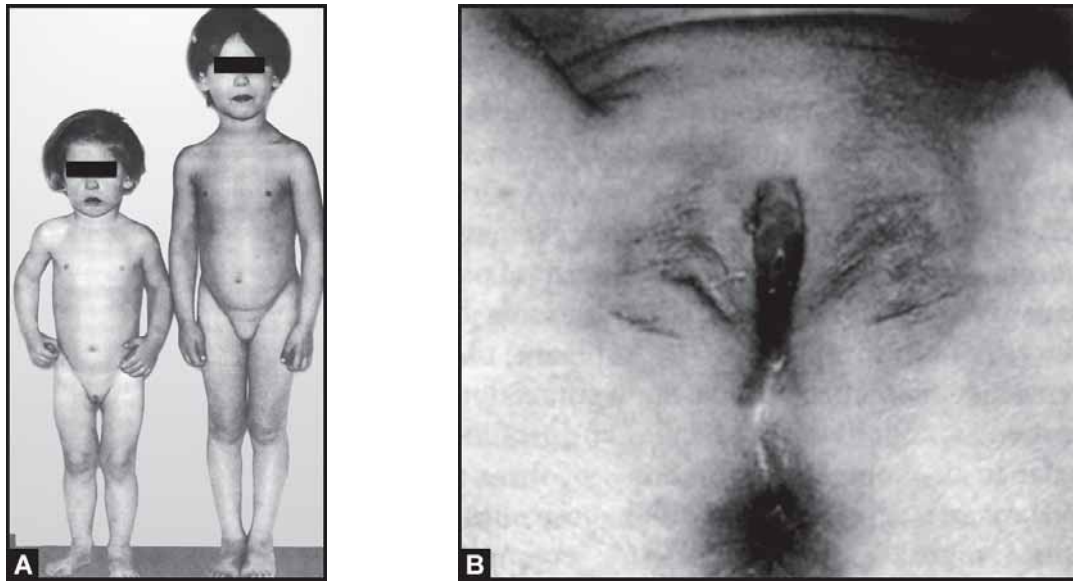
#### **Combinations of Chromosomal, Genetic and Gonadal Causes of Intersex**

From the foregoing, it is evident that states of intersex often have a complicated aetiology with several



**Figs 14.21A to C:** The testicular feminisation syndrome. A girl aged 18 years complaining of primary amenorrhoea although her breasts had developed well since she was 12 years old. Interests and outlook feminine; chromosome pattern 46,XY. Undescended testes were removed and there was no sign of tubes or uterus at operation. Following operation the girl did not experience any reactions and the output of oestrogens in the urine remained virtually unchanged, within the male range. She married one year later and had normal heterosexual libido and coitus, (A) A very attractive female figure with a well-developed bust and a smooth hairless skin, (B) Feminine external genitalia although the pubes and vulva are characteristically almost devoid of hair. The vagina is of good length although it must represent a urogenital sinus component only, (C) Section of one of the gonads, showing inactive seminiferous tubules and large islands of interstitial (Leydig) cells

background factors operating. Thus, the testicular feminisation and congenital adrenogenital syndromes, although mediated by hormone influences, are basically genetic in origin and are strongly familial. The same is true of the not-uncommon conditions in which men have breasts, partly feminised genitalia, and personalities. A good example is penile hypospadias in an otherwise masculine individual with a 46,XY karyotype. It is reckoned that 75 per cent of men suffering from hypospadias have an inherited taint of some kind (Figs 14.22A and B and 14.27). This deformity, however, is



**Figs 14.22A and B:** (A) Two siblings, aged 2 and 4 years respectively, reared as girls. The older one had already been operated on for bilateral hernias, and testes had been returned to the abdominal cavity from the inguinal canals. External genitalia identical. Chromosomal sex = XY in both cases. The height scale is in feet. The younger child was treated by removal of undescended testes, this being justified by the appearance of the external genitalia. (B) The external genitalia of the younger child. A very poorly developed phallus is associated with gross hypospadias and the split scrotum looks like labia majora except for strong evidence of a dartos muscle

not only familial but is often associated with cryptorchidism, the testes being hypoplastic. Is it testicular hypoplasia which results in non-descent or vice versa? And is the hypospadias the result of a failure in androgen secretion or of an inherent genetic defect in the target organ?

Again, the male phallus may be underdeveloped and the scrotum split despite the presence of apparently normal testes (Figs 14.23A and B). A urogenital sinus component of vagina may or may not be present in association with testes, usually un-descended (Figs 14.21A to C and 14.24). This may be determined by sex chromosomal, genetic or hormonal factors with considerable interplay.

Similar considerations apply to the development of postpubertal feminism in the male (for example, gynaecomastia) and of virilism in the female (for example, hirsutism). When these conditions go with an apparently normal sex chromosome make-up, an underlying factor may be weak or strong masculinising genes on autosomes, unrecognised mosaicism or some fault in the Y chromosome of a 46,XY individual. Hypospadias is sometimes related to deletion of one

small portion of the Y chromosome. As methodology becomes more refined more errors of this kind may come to light.

### PSYCHOLOGICAL SEX

Many men and women psychologically dominated towards sexual inversion, a persistence of childhood tendency.

- a. Effeminate behaviour
- b. Speech
- c. Dress
- d. Sexual inclination

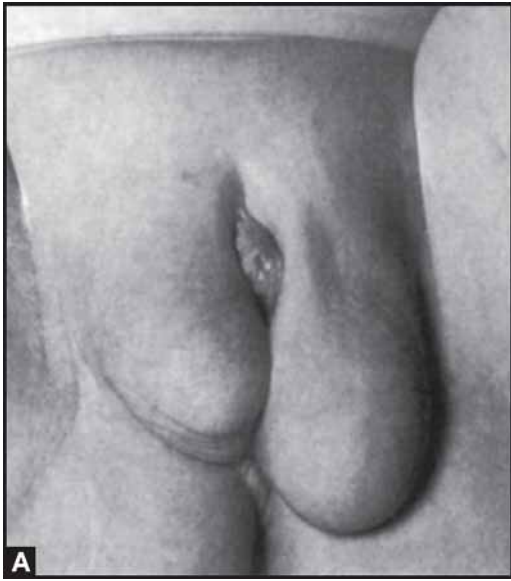
### Transvestism

- a. Male and female type
- b. Male type more common i.e. a male likes to wear female clothes and does not think he is a male.

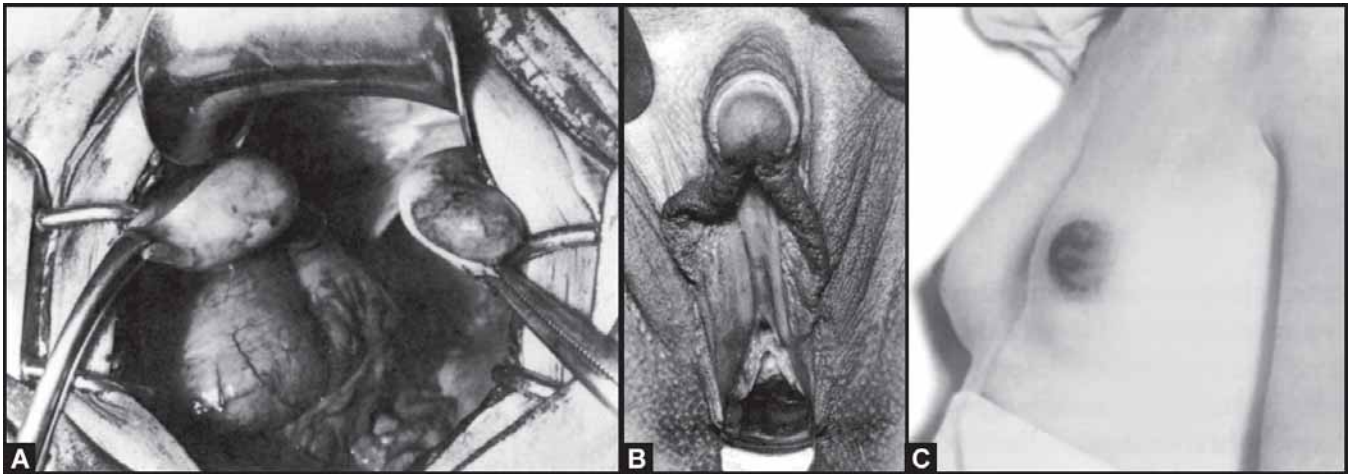
### Transsexuality

The person starts believing that he or she belongs to opposite sex i.e. mind trapped in wrong body.





**Figs 14.23A and B:** (A) The external genitalia of a child aged 9 months and registered as a girl. A poorly developed hypospadiac penis is associated with a split scrotum. The presence of the gonads in the 'labia' strongly suggests that they are testes and this was confirmed by biopsy. Sex chromatin pattern negative; chromosome analysis not available at the time. Because the poor development of the phallus would have made life as a male inadequate, the penis and both testes were removed and the child continued to be regarded as a girl and developed well as such. (B) The same patient at the age of 14 years, attractive and feminine physically and psychologically; the bust has now been developed by giving oestrogens



**Figs 14.24A to C:** Cryptorchidism in a registered female, a common form of intersex. The patient concerned, aged 21 years, had been brought up as a girl but had never menstruated or developed a bust. Although not very muscular she became an outstanding 'woman' athlete. Slight facial hirsutism and voice change were noticed at the age of 20 years; the phallus had been enlarged as long as she could remember. Buccal smears were chromatin positive but the chromosome complement was not determined. The presence of testes almost certainly means the presence of a Y in the karyotype so XXY or a mosaic are possibilities, (A) The findings at laparotomy; testes present on each side of the pelvis and these have suppressed the persistence of any müllerian duct tissue, (B) The external genitalia appear female except for the large phallus; behind the urethral meatus is a vagina 3 cm in depth and this must represent the urogenital sinus component only, (C) Good development of the breasts resulting from 3 months' treatment with oestrogen. Before this treatment, and in view of the weak masculinity and the woman's strong desire to remain female, the gonads and the phallus were removed. This patient, as so often in cases of intersex, had had an operation for bilateral inguinal hernias in childhood. Oestrogen therapy caused a recurrence of the hernia on one side; this is a recognised reaction in these cases

## SEX OF REARING

There are many males and females, brought up by their parents in the mistaken identity. They, over the years, acquire habits and mental inclinations of the opposite sex to such a degree as to pass as members of wrong sex.

## THE MANAGEMENT OF ABERRATIONS OF SEX PRESENT AT BIRTH

### Diagnosis

The earlier in life that errors in sex differentiation are recognised and treated, the better are the prospects for the individual to find a satisfactory place in society. In examining every newborn it is important to look not only for skeletal and visceral deformities (which may give an immediate lead to a diagnosis of Turner syndrome) but for anomalies of the external genitalia. It is easy to be deceived by casual examination of these. The appear-



**Fig. 14.25:** The external genitalia of a child aged 3 months and registered as female. Her sex was questioned, however, because of the prominent phallus. Buccal smears were reported as being chromatin-negative and intersex associated with cryptorchidism seemed possible. It was decided to await further developments and, when the child was 1 year old the genitalia appeared normally female. At that time the chromatin sex was reported positive and the conclusion was that no abnormality existed. Slight enlargement or prominence of the clitoris is not uncommon in infancy and can be deceptive. Chromatin sexing can be unreliable, especially in recently born babies. Chromosome analysis was not available when this case was seen

ances are not always easy to interpret and a normal clitoris is sometimes relatively large (Fig. 14.25). Evidence of dartos muscle in what seem to be labia majora suggests that they really represent a bifid scrotum. A median perineal raphe is a male characteristic.

Whenever the sex is ambiguous, the chromosome pattern should be determined. Hormone assays of blood may help. At some stage, not in the newborn infant, ultrasound examination under general anaesthesia and laparoscopy may become necessary to discover the exact state of the genitalia.

When as much information as possible is available and the parents of the child, or the patient if an adult, have been consulted, a decision is made as to the sex to be adopted permanently. In this, prevarication may be necessary for a short time in the case of a small infant, for not all diagnostic methods can be brought to bear at that stage.

### Investigations

- a. History
  - Familial
  - Drugs in pregnancy
  - Virilising symptoms in pregnancy
  - Operations in childhood
  - Amenorrhoea
  - Fertility if adult
- b. Examination
  - Height/span ratio (normal 1:1)
  - Special features e.g. cubitus valgus, webbing of neck
  - Secondary sexual characters
  - External genitalia
  - P/V if possible
  - Size of clitoris
  - Location of urethral meatus
  - Hymen
  - Length of vagina (blind pouch)
  - Masses in labia or inguinal canal
  - Hernia
  - Intelligence quotient (IQ)
- c. Tests
  1. Sex Chromatin study
    - Barr body
    - Y fluorescence
    - Cyanophilic cytoplasm

This can diagnose 95-98% aberrations of chromosomes.

## Chromatin + ve

- True female hermaphroditism
- Adrenal cortical hyperplasia
- Mother receiving androgens

## Chromatin – ve

- Male hermaphroditism
- Testicular feminising syndrome
- True hermaphroditism (very rare)

## 2. 17- Ketosteroids in 24 hours urine.

Normal values are:

<i>Upto 10 days</i>	<i>High</i>
1 month	1 mg
1 year	0.5 mg
5 years	1 mg
7 years	1.5 mg
9 years	2 mg
Adults	5-15 mg

The values are excessively increased in adrenogenital syndrome.

17 ketosteroid can also be detected in amniotic fluid for prenatal diagnosis.

3. Adrenal stimulation/suppression tests
4. Ovarian stimulation/suppression tests
5. Vaginography/Vaginoscopy
6. Intravenous urography (IVU)
7. Gonadal biopsy
8. Laparoscopy
9. Exploratory laparotomy
10. Psychiatric evaluation

### Treatment of Intersex

#### A. Principles

1. Sex of rearing should not be changed if possible
2. Careful counselling
3. It is easier to castrate a small penis or enlarged clitoris and convert to female genitalia.
4. Abnormal gonads have a 4% risk of malignancy so should be removed.
5. Supportive hormone therapy
6. Counselling for sexual activity and fertility.

#### B. Treatment may be

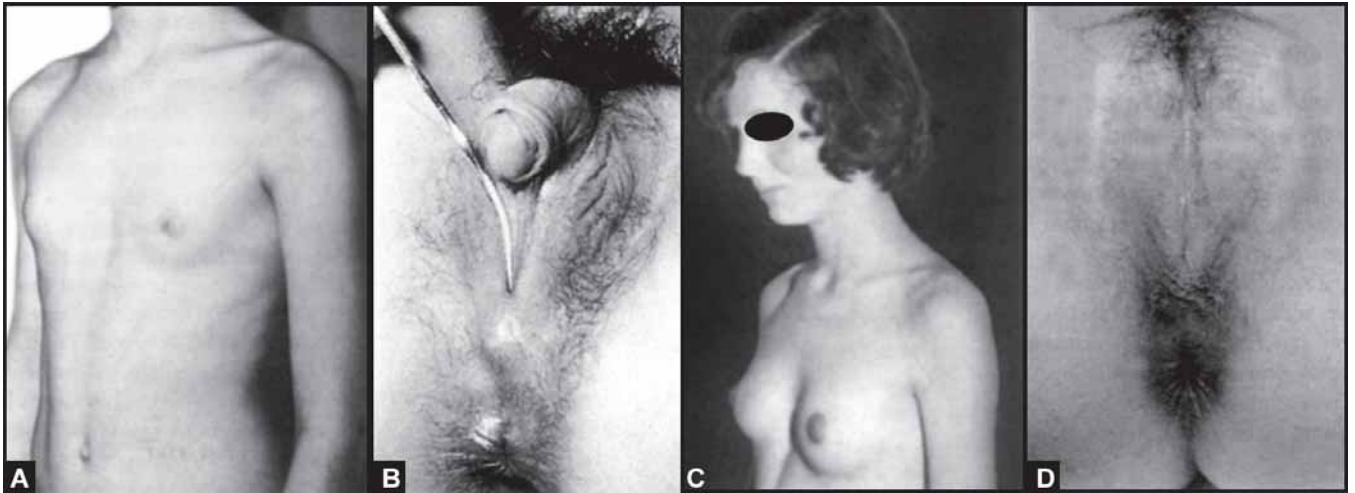
1. Medical
2. Psychological
3. Surgical

Once the above decision is taken, efforts should be made to accentuate the agreed sex by surgery and by endocrine therapy. The girl suffering from CAH can be

made and kept female by a maintenance dose of adrenal corticoids and their substitutes, and by operations on the vulva. The treatment of hypospadias in an otherwise normal male is by plastic surgery. But in most cases in which there are anomalies and discrepancies, the sex of the individual is best allocated according to the secondary sex characters and especially the appearance of the external genitalia. If the hypospadiac phallus of the baby boy with undescended testes is so poorly developed that it can never be made to function sexually, the gonads and the phallus are best removed and the child then reared as a girl (Fig. 14.23). If the child with cryptorchidism and hypospadias has already been conditioned to femininity, then this management is appropriate even if the phallus is moderately well developed (Fig. 14.26).

Indeed, when a condition of intersex first comes to light at or after puberty, the general rule is to mould the sexual apparatus to match the individual. The uterus and ovary found in an apparent man should be removed; similarly the testes discovered in an apparent girl. It is sometimes argued that it is unnecessary to remove undescended testes from a phenotypic girl, and that it may be undesirable in that they contribute to her hormone status. In my view their removal is generally indicated because: their hormone contribution is androgenic and, except in the case of the feminising testes syndrome, can cause hirsutism and voice changes at puberty; they may become the site of malignant disease. Even streak gonads in a patient with a Y chromosome can undergo tumour formation and it seems desirable, although probably not legally important, to remove male tissue before the individual is advised to live and marry as a woman. Psychologically, however, it is important that the nature of the gonad removed should not be revealed to the patient. A girl or woman can never accept that she can take her proper place in society if she knows that she has, or has had, a testis; it is enough for her to be told that her ovary(ies) is incompletely developed. Similarly, a man would be shattered to learn that he had had an ovary or uterus excised.

In planning treatment, it is necessary to recognise that femininity is neutral and that masculinity is something positive which is superimposed. The removal of testes inevitably encourages subsequent femininity. Indeed, it is easier to make a good woman than a passable man. When testes are excised, the development of breasts and



**Figs 14.26A to D:** A girl aged 12 years whose voice was beginning to deepen but without evidence of facial hirsutism. Karyotype = 46,XY, determined from cultures of skin and testicular tissue, (A) The figure is rather masculine but the breasts are beginning to enlarge; the patient's interests and outlook were feminine, (B) The external genitalia showing a male phallus with hypospadias and dartos muscle activity in the split scrotum; the sound marks the urethra. Testes were in the inguinal canals and there was no evidence of vagina, uterus or tubes. The gonads and the phallus were removed and the patient treated with oestrogens. (C) A more feminine figure and good breast development 6 months after operation and commencement of oestrogen therapy, (D) The 'Vulva' 6 months after operation

feminine traits is encouraged by the administration of oestrogens at and after the normal age of puberty (Figs 14.23 and 14.26). This treatment, however, when it follows the removal of undescended testes, commonly causes inguinal hernia formation (Fig. 14.24). It is therefore important to close the inguinal canals at the time of orchidectomy. The timing of operative treatment is also important. The removal of the phallus from a 'girl' should, if possible, be performed before she is aware of its presence. This means before the age of 5 years, and some would say 2 years. Testes are best excised before the age of 14 years.

'Girls' from whom testes are removed commonly have a urogenital vagina of good dimensions and this permits satisfactory coitus and successful, if infertile, marriage. If a vagina is not present, an artificial one can be created if the circumstances justify it.

Once an individual is conditioned to living as a member of one sex, he or she finds it extremely difficult to adjust to the other. So when an older child or an adult is found to have been reared contrary to the nature of the gonad or other sex characters, it is rarely wise to advise a change in sex. The result is often one of misery (Figs 14.27A to D). The only cases in which a late change in sex is ever successful are those in which the genital

apparatus is such that, with the new sex, the individual is capable of a normal married life and preferably of reproduction too.

Although converting a female to a male is technically more difficult, it has been done successfully. The phallus is fashioned out of flaps rotated down from the anterior abdominal wall and inflatable prostheses are inserted to make it functional.

The Klinefelter and YY syndromes have no specific treatment. Aplastic testes cannot be stimulated to produce spermatozoa but, if the interstitial cells are also defective, replacement therapy with testosterone is indicated.

The girl suffering from Turner or other syndromes associated with streak gonads can never be made fertile but, *when she reaches the age of puberty*, can have her secondary sex organs and characters developed by replacement therapy with oestrogens and progestogens in the form of the oral contraceptive pill, or sequential conjugated oestrogens with progestogens. Such treatment needs to be continued for 1-3 years, depending on how well the breasts develop. Subsequently, if treatment is discontinued, amenorrhoea returns, but the bust measurement does not usually go down even though the mammary gland atrophies (Fig. 3.16). In these



**Figs 14.27A to D:** Hypospadias and cryptorchidism in an otherwise normal male. This individual was reared as a girl and was first seen at the age of 17 years when she complained of primary amenorrhoea and hirsutism. The voice was then deep and she walked with a manly stride. Her father had had three operations for hypospadias. When the true state of affairs was elucidated, this person elected to change sex and she was re-registered as a male. He subsequently had four operations for hypospadias and married. The outcome was a failure for he proved both impotent and sterile, (A) The external genitalia. (B) Facial acne and hirsutism. (C) Individual dressed as a girl, (D) After being re-registered as a man; one month's interval between (C) and (D)

women, marriage should be preceded by further courses of hormone replacement therapy or low-dose contraceptive pills to overcome vaginal atrophy and thus permit the establishment of coitus. However, there is a definite place for continuation of hormone replacement therapy on a long-term basis to prevent osteoporosis and other problems of oestrogen deficiency.

The extragenital deformities found in Turner and allied syndromes are treated according to their nature and the degree of disability they cause. The possibilities include plastic surgery for the webbing of the neck, correction of bony deformities and cardiac surgery.

Little more than advice is needed for the woman suffering from the triple-X syndrome. The ovaries are likely to be refractory but it is nevertheless reported that they can sometimes be made to ovulate by treatment with gonadotrophins.

## SPECIALISED TREATMENT SCHEDULES

### Testicular Feminisation Syndrome

- i. Reared as female
- ii. Gonadectomy is a must as the testes have a high chance of malignancy

- iii. Gonadectomy must be done after puberty
- iv. Hauser has recommended no gonadectomy. According to him gonadectomy converts symptomless individual to menopausal individuals. According to him risk of malignancy is 10% and is so after the age 40.

### Male Hermaphroditism

- i. Treatment depends on the degree of development of the phallus
- ii. In the presence of a well developed phallus they are reared as males.
- iii. In the absence of a well developed phallus, they are reared as females by excising the enlarged clitoris and a gonadectomy before puberty, i.e., before masculinisation.
- iv. Vaginoplasty or separation of labioscrotal folds
- v. Maintenance with female hormones.

### True Hermaphroditism

- i. Corrective surgery
- ii. Medical therapy. Corticosteroids are given to reduce the increased ACTH levels

- iii. Corticosteroids are given at high doses and then tapered according to 17-KS levels
- iv. The dose is adjusted to the lowest level to avoid complications
- v. Medical therapy stops further adrenal hyperplasia and masculinisation
- vi. If of the salt-losing type then treatment is given with deoxycorticosterone.

### Turner's Syndrome

Possibility of ovarian transplantation may impart fertility and natural endogenous hormones for phenotypic development.

#### Principles of Surgical Therapy

1. Clitoris should be excised in infancy either total or partial. This may lead to loss of orgasm.
2. Division of perineal body can be done later on
3. Treatment of major urogenital abnormalities
4. Reconstructive surgery – Vaginoplasty
5. Ablative surgery – Gonadectomy  
– Phallectomy  
– Septum removal
6. Curative surgery – Adrenalectomy  
– Gonadectomy

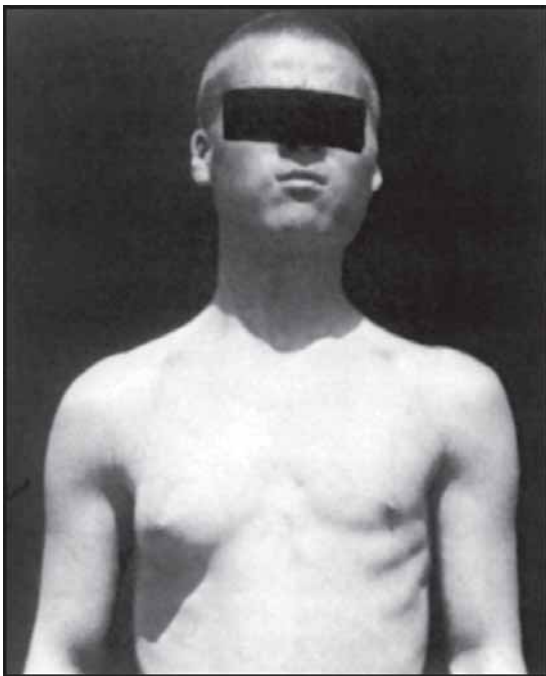


Fig. 14.28: A male suffering from unilateral gynaecomastia of unknown cause (Mr J.M. Leggate's case)

### INTERSEX DEVELOPING AFTER BIRTH

Sex differentiation after birth is controlled by hypothalamic-pituitary, thyroid, adrenal and gonadal hormones as well as by inherent genetic forces. Any disturbances in the functions of these glands, due to a genetic taint or to acquired disease, can modify the sexual apparatus and behaviour of the otherwise normal male and female. The development of feminine traits in the male is called *feminism*, that of masculine traits in the female, *virilism*.

### FEMINISM

#### Manifestations

##### Sex Organs

Feminine features appearing after birth include failure of the testes to descend or develop, hypoplasia of the phallus and gynaecomastia. Galactorrhoea can, but usually does not, accompany gynaecomastia. Gynaecomastia can occur without genital aberrations and may be unilateral or bilateral (Figs 14.28 and 14.29).

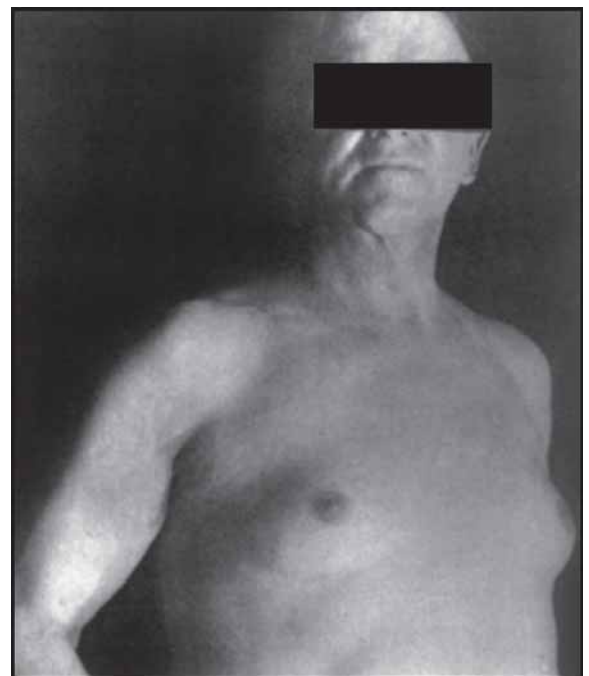


Fig. 14.29: Gynaecomastia which developed rapidly in a man aged 50 years. The cause proved to be the application of an oestrogenic ointment for pruritus ani; only two tubes were used to produce this effect

### *Secondary Sex Characters*

Feminism is indicated by a feminine figure with poor muscular development, broad hips and narrow shoulders, a characteristic gait, a high-pitched voice, a smooth skin with a weak growth of hair on the trunk and face.

### *Personality and Outlook*

Caution is necessary in regarding these as sexual characteristics since they depend largely on fashion and custom in a particular community (*see below*).

### *Libido*

Heterosexual impulses may be weak or absent and the man may be impotent. Homosexuality and transsexuality are extreme examples of abnormal libido (*see Chapter 45*).

## Causes

### *Physiological*

Slight gynaecomastia (often familial) is common in pubertal and adolescent boys but disappears in 1½ years. It is caused either by increased hypothalamic-pituitary activity or by temporary hyperoestrogenism resulting from disturbed metabolism of androgens.

### *Genetic and Constitutional*

An inborn weakness of masculinising genes explains some disorders of behaviour and personality. It can also account for a weak beard, high-pitched voice and failure of the phallus to develop at puberty. This is because the sensitivity of target organs to sex hormones is determined genetically.

### *Psychological*

Many examples of effeminate behaviour and appearance have an entirely psychological basis. Transvestism and transsexuality are gross forms (*see Chapter 45*).

### *Androgen Deficiency*

Hypoplasia, injury, disease and removal of either the adrenals or the testes can cause feminism. If the testes are removed before puberty the resulting eunuch has a tall feminine figure, soft hairless skin, a high-pitched voice, and weak or absent heterosexual interests. The

effect of castration later in life is less obvious but gynaecomastia is recorded as a sequel.

The undescended testis or the one damaged by orchitis usually preserves its endocrine function even though it does not produce spermatozoa.

### *Oestrogenism*

Excessive production of oestrogen is a possible explanation of the rare cases of feminism associated with *adrenal cortical tumours* and *hyperplasia*. The administration of oestrogens to the male inhibits testicular activity, suppresses sex drive and causes gynaecomastia (Fig. 14.29). Feminism is also some-times seen when the liver is damaged by disease or by malnutrition: this is because the liver is no longer able to inactivate oestrogen normally secreted by the adrenal. Gynaecomastia in association with raised blood oestrogen levels is described as a complication of refeeding after starvation, pulmonary tuberculosis, chronic renal failure, renal dialysis, psoriasis, eczema and bronchogenic carcinoma. In the case of the last, the tumour itself can secrete oestrogens, and some-times other hormones including gonadotrophins.

### *Diseases of the Pituitary, Hypothalamus and Midbrain; Hyperthyroidism*

When these cause feminism they do so by suppressing the androgen production of the adrenals and testes, or by increasing the oestrogen secretion of the adrenals.

### *Drugs*

Testosterone and other androgens, by being metabolised to oestrogens, can cause gynaecomastia in young boys. This condition is also seen following the administration of gonadotrophins for cryptorchidism, and of drugs such as reserpine and phenothiazine derivatives which act on the hypothalamus. Digitalis and methyldopa are also reported causes.

## Treatment

This varies with the cause of feminism and its manifestation. Oestrogenic tumours can be removed, cryptorchidism and gynaecomastia may require surgery. An androgen deficiency can be made good by giving testosterone, but this hormone is of little value when the cause of feminism is constitutional, psychological or a genetically determined insensitivity of the target organs.

## Virilism

### Manifestations

Because of variations in the sensitivity of target organs, these can occur singly or in various combinations. This sensitivity may depend on a high or low capacity of the local tissues to convert testosterone to its active end product which mediates cell response.

### Sex Organs

Hypertrophy of the clitoris, and hypoplasia or atrophy of the breasts and the genital tract, are the main evidences of acquired anatomical virilism (Figs 14.30A to D). Functional virilism includes amenorrhoea, infertility and failure to lactate.

### Secondary Sex Characters

Virilism is indicated by coarse features, acne, a heavy angular build, well-developed muscles, broad shoulders and narrow hips with a striding gait. Exceptional athletic skill, especially in those sports which involve throwing, can betoken masculinity. Many international women athletes have been virilised females or congenital intersexes, and some have been disqualified on this account. Other signs of virilism are a prominent larynx (Adam's apple) and a deep voice.

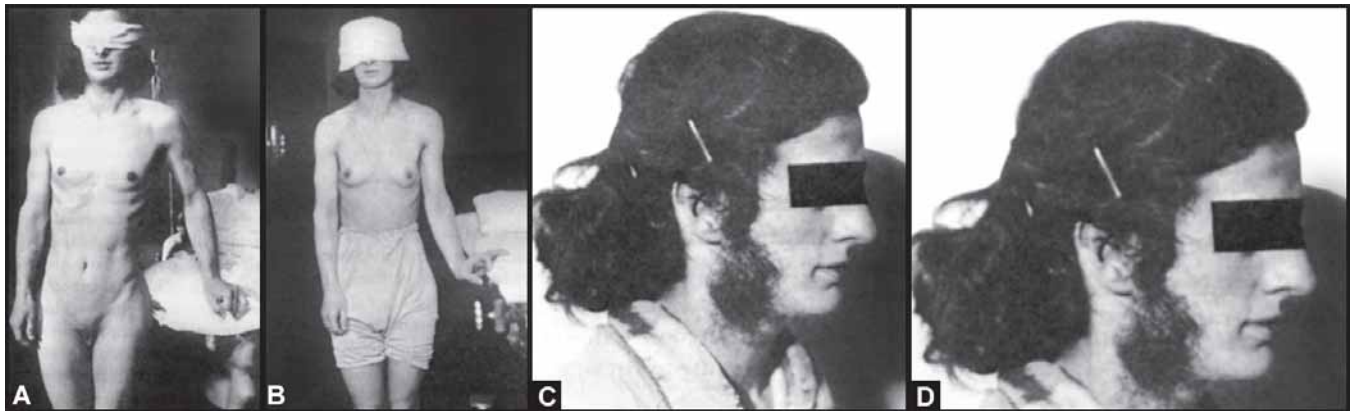
### Hair

A growth of hair over the triangle between the pubes and the umbilicus is said to be a masculine trait but occurs in approximately one-third of all women. It carries no special significance. Similarly, a slight down on the upper lip and on the arms and legs is as much a female as a male characteristic. The first is found in 25 per cent of young normal women, and in 40 per cent of those aged more than 40 years. Seventeen per cent of normal women aged 18-25 years have hair on the chest and breasts.

The more important signs of virilism are hirsutism affecting the beard area and back; a heavy growth of hair on the arms and legs; eyebrows which extend over the bridge of the nose; hair in the nostrils and ears, and on the dorsal aspects of the toes; baldness of the scalp. Significant hirsutism is accompanied by thickening of the affected skin whose collagen content is increased (male features). The sweat-gland response is also masculine. So hirsutism is sometimes called *cutaneous virilism*.

### Personality and Outlook

Under this heading come a forceful manner, a weak maternal instinct, disregard for appearance and dress, and an assumption of male attire and habits. In respect of the last, it is a fashion in many communities for normal girls and women to assume what is sometimes



**Figs 14.30A to D:** Postnatal adrenogenital syndrome caused by an adrenal tumour. Woman aged 31 years complaining of primary amenorrhoea and hirsutism. Genitalia infantile except for enlargement of the clitoris. An adrenal cortical adenoma was found and removed; thereafter menstruation became established spontaneously in 3 months, (A) Before operation (abdomen and pubes shaved). Note the masculine figure and enlargement of the clitoris, (B) Three months after operation and without hormone therapy. The breasts are now well formed and increased modesty is indicated by the patient's refusal to be photographed nude, (C) Before operation, showing the growth of hair on the face; the hair on the chin and upper lip had been removed with a razor, (D) Facial appearance one year after operation. The growth of hair on the face ceased only very slowly and, at the time of photography, this woman still had to shave, although infrequently



regarded as the traditional masculine role and dress, whilst their husbands and brothers adopt 'female' hair styles and clothing, and share with them domestic and parental duties. This move towards 'unisex' merely emphasises that many of the sexual differences in behaviour and outlook are the creation of society and are not inherent.

### *Libido*

Heterosexual impulses are weak or absent. The virile woman is usually asexual although likely to have platonic friendships with those of her own sex. Frankly homosexual desires and activities are sometimes regarded as virilism.

## Causes

### *Constitutional*

Virilism of a minor degree is usually an inherent constitutional trait (*see* Fig 14.13); hirsutism and a masculine build, for example, show strong familial and racial tendencies. Hirsutism by British standards is general amongst women of Mediterranean races. The Chinese, however, have little body hair. The majority of the large number of women who seek advice for facial hirsutism have no gross endocrine disturbance; their only trouble is that they have hairy parents, or parents with hairy brothers and sisters. They generally have good menstrual and reproductive functions and assessment of ovarian and adrenal function proves normal. Their problem is undue sensitivity of hair follicles to normal amounts of androgen.

If the onset of hirsutism is acute, or associated with masculinisation, the androgen excess might be due to a functional tumour of the ovary or adrenal glands (*see below*).

### *Psychological*

Masculine trends in outlook and behaviour are often of psychological origin. For one reason or another there is a conscious or subconscious determination to suppress or deny the female sex, and this sometimes amounts to overt transvestism and trans-sexuality.

### *Oestrogen Deficiency*

Failure of the ovaries to function, or removal of the ovaries, results in genital hypoplasia or atrophy but does *not* lead to positive virilism.

## Excessive Androgen Stimulus

### *The Administration of Androgens*

Testosterone and danazol therapy in women, unless carefully controlled, causes facial hirsutism, amenorrhoea, atrophy of the breasts and uterus, and deepening of the voice. The last is permanent, hirsutism may persist but the others disappear when treatment is suspended.

### *Adrenal*

Androgenic tumours of the adrenal cortex, which may be benign or malignant, cause a *postnatal* adrenogenital syndrome which is biochemically different from the congenital one. The manifestations are also different in that the genital organs are normally formed before being exposed to an excessive androgen stimulus. However, the clitoris enlarges, menstruation and follicular ripening are suppressed (Fig. 3.11), the breasts and uterus remain infantile or undergo atrophy, and there are the usual manifestations of virilism including personality changes (Figs 14.30A to D). The types of tests used in the diagnosis of virilism are to measure the concentration of some or all of the following: DHEA, DHEA sulphate (DHEAS), testosterone (free preferable to total) and androstenedione by radioimmunoassay techniques in the peripheral circulation. Adrenal tumours generally produce elevated plasma DHEAS levels which are not suppressed with high doses of dexamethasone. Methods such as IVP, ultrasonography and computerised tomography (CT scan) may demonstrate these tumours.

The adrenogenital syndrome developing in childhood (not having been present at birth) is always caused by a tumour. After puberty, however, it may be due to so-called *postpubertal adrenal cortical Hyperplasia*, a condition which is probably not different from constitutional virilism associated with evidence of minor changes in adrenal function. The clinical picture presented is less dramatic than that produced by an adrenal tumour from which adrenal hyperplasia is distinguished by the facts that: it does not usually suppress menstruation completely; it results in excretion levels of 17-ketosteroids (usually less than 50 mg/24 hours); and this level can be raised by giving ACTH and lowered by dexamethasone.

Because of the adrenal response, severe burns and other stresses sometimes initiate hirsutism.

In Cushing's syndrome (Fig. 37.8), hirsutism and oligomenorrhoea are associated with a rapid increase in

weight, striae formation, hypertension, polycythaemia, and hyperglycaemia. These reflect a disturbance in the output of sex hormones and corticosteroids by the adrenal. The urinary excretion of 17-ketosteroids is moderately raised and that of 17-hydroxycorticoids grossly raised. Plasma cortisol levels are assayed in the late evening and after a single-dose overnight dexamethasone suppression (1 mg at 11 pm). If plasma cortisol is less than 5 µg/dl it is normal, whereas if it is greater than 10 µg/dl it is diagnostic of adrenal hyperfunction. An abnormal result can be confirmed by the 2-day low-dose dexamethasone suppression (0.5 mg 6-hourly) test. Twenty-four-hour urinary 17-hydroxysteroids and free cortisol can be assayed together. The cause is often a primary adrenal disorder. A malignant or benign tumour may be present but sometimes there appears to be nothing more than an oversensitivity of the gland to normal amounts of ACTH.

The anterior pituitary may show a predominance of basophil cells (*pituitary basophilism*) but this is probably the result rather than the cause of the adrenal upset. Occasionally, however, the syndrome is caused by a primary hypothalamic or pituitary lesion.

A true Cushing's syndrome is quite rare. Many suspected cases prove to be nothing more than fat and slightly hairy women with oligomenorrhoea but without a demonstrable gross endocrine disturbance. This picture is sometimes labelled 'Cushingoid'. Other conditions associated with this presentation include alcoholism, response to stress, anorexia and bulimia nervosa.

### Ovary

Certain rare tumours of the ovary such as the *androblastoma* and the *hilus cell tumour* are androgenic. They usually occur in young adults and cause enlargement of the clitoris, suppression of menstruation, hirsutism, acne and voice change. These features are not associated with an increase in the output of 17-ketosteroids but if the serum testosterone level is above 1.5 ng/ml the possibility of an ovarian tumour should be considered. Secondary malignant deposits in the ovaries can also make these organs androgenic.

The Stein-Leventhal syndrome was characterised by oligomenorrhoea, infertility, heavy build and hirsutism in association with polycystic ovaries. This condition is now recognised to be part of a spectrum of clinical manifestations, termed the *polycystic ovary syndrome (PCOS)* (see Chapter 37). Insulin resistance and

hyperinsulinaemia are recognised correlates and are exacerbated in the presence of obesity. Using pelvic ultrasound, polycystic ovaries are seen in up to 20 per cent of normal women and in higher numbers in those with evidence of hyperandrogenism, e.g. acne, hirsutism and alopecia.

The cause is an error in hormone biosynthesis in the ovary although an adrenal component for the hyperandrogenism is also suggested. The theca cells are increased in number and also produce an excess of androstenedione per cell. Determination of the follicle-stimulating hormone (FSH) and luteinising hormone (LH) levels may help to confirm the diagnosis of polycystic ovaries. These are assayed on the second or third day of the cycle. FSH levels may be normal or slightly low whereas LH levels are raised leading to a reversal of the normal FSH:LH ratio. In fact, LH levels may be 3 to 4 times those of FSH. Serum testosterone, androstenedione (AH) and dehydroepiandrosterone sulphate (DHEAS) levels may also be increased whereas sex hormone binding globulin (SHBG) level is decreased. Ultrasound shows enlarged ovaries, with multiple cysts 6-8 mm in diameter arranged around the periphery, and stromal hyperplasia. At laparoscopy, these plump ovaries have a thickened capsule with multiple follicles.

### *Diseases of the Pituitary, Hypothalamus, Midbrain and Base of Skull*

These conditions can produce a measure of virilism by way of their effect on the adrenal or gonad. *Acromegaly*, for example, is characterized by angular masculine features, heavy build, amenorrhoea, voice change, loss of libido and atrophy of the breasts and uterus (Fig. 38.1). It is not infrequently mistaken for the adrenogenital syndrome. Prolactin-secreting tumours can have the same effect.

### Drugs

Apart from androgens, other hormones and drugs such as ACTH, progestogens, corticosteroids and anabolic agents can sometimes cause virilism.

### Diagnosis

Successful treatment depends on finding the cause of the virilism. This can sometimes be determined by clinical methods. Vaginal examination, for example, may reveal a palpable ovarian tumour. Generally, special

investigations are necessary: hormone assays — measurement of serum testosterone, sex hormone-binding globulin, FSH, LH, AH, DHEAS, 17-OHP; studies of the effects of giving adrenal cortical stimulators and depressants; electrolyte and metabolic studies, radiographs of the sella turcica; CT scanning and ultrasonography of the pelvis, and intravenous pyelography (Figs 14.31A and B); selective catheterisation of the adrenal veins for hormone assays; pelvic examination under anaesthesia and laparoscopy.

## Treatment

### Surgical

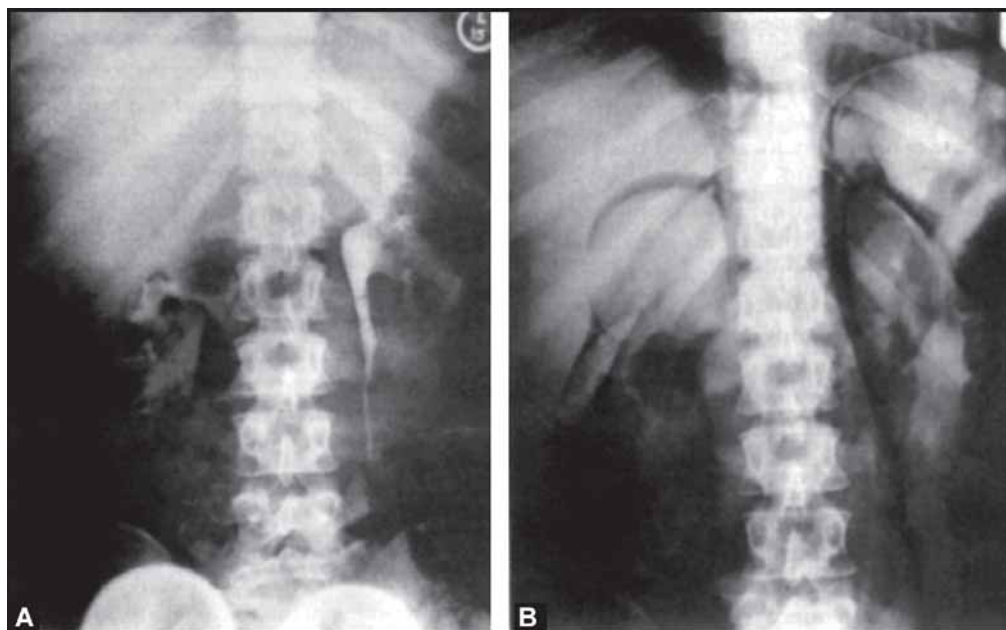
Removal of androgenic tumours of the adrenal and ovary results in reversal of all signs of masculinity except deepening of the voice (Figs 14.30A to D). The effect is not always as dramatic as might be expected in that the hirsutism subsides only slowly over the course of many months or years; the clitoris may also never revert completely to normal. Both ovarian and adrenal androgenic tumours may be malignant so the ultimate result is not always good from the stand-point of life and health.

For adrenal cortical hyperplasia and for Cushing's syndrome, partial adrenalectomy gives unsatisfactory

results. If a primary pituitary lesion can be excluded, and if the condition is sufficiently serious, total bilateral adrenalectomy followed by substitution therapy is sometimes practised. In the case of polycystic ovaries, treatment depends on whether the patient desires conception or not. For those desirous of procreation, induction of ovulation should be tried (*see* Chapter 5). In women who do not want conception at the time of presentation, oral contraceptive pills are the treatment of choice. Wedge resection of the ovaries, sometimes advocated in the past as treatment for PCOS, never improves hirsutism even if it is followed by cure of other symptoms. This procedure has now been replaced by laparoscopic ovarian drilling and is done only if medical induction of ovulation fails. Its effects are usually temporary.

### Medical

If drugs are the cause of virilism they are discontinued. Mild acne requires only regular washing with soap and water or with lotions containing chlorhexidine. If it does not respond, local nightly application of preparations containing benzoyl peroxide and retinoic acid is advised. For severe acne, antibiotics for at least 3 months (or longer, if necessary) are advised.



**Figs 14.31A and B:** Radiological demonstration of an adrenal tumour, (A) Intravenous pyelography shows distortion and downward displacement of the right kidney, (B) A retroperitoneal pneumogram in the same case outlines the tumour; this sort of investigation is not without risk and has been superseded by ultrasonography, CT scan and selective catheterisation of the adrenal veins for hormone assays

## Hormonal

### Oestrogen

Although it is the 'female sex hormone', oestrogen never completely overrides an androgen effect. It is used, alone or in combination with progestogens, and is effective in decreasing adrenal and ovarian steroid production and reducing hair growth in two-thirds of hirsute patients. Combined oral contraceptive pills containing ethinyl oestradiol with desogestrel or gestodene have been found to be useful in mild hirsutism.

### Medroxyprogesterone Acetate

It decreases gonadotrophin-releasing hormone production (GnRH) production and gonadotrophin release and therapy decreases testosterone and oestrogen levels. It can be administered orally (20-40 mg daily in divided doses) or intramuscularly (150 mg of the depot form every 6-12 weeks) with excellent results in decreasing hair growth.

### GnRH Agonists

Leuprolide acetate intramuscularly every 4 weeks decreases hair growth and diameter in idiopathic hirsutism and in hirsutism with PCOS. Add-back therapy with oral contraceptives or conjugated oestrogen prevents bone loss, vasomotor symptoms and genital atrophy.

### Corticosteroids

Dexamethasone can be tried in cases of postpubertal adrenal cortical hyperplasia and PCOS. The rationale is an attempt to depress the output of ACTH by the pituitary. Low doses of 0.25 mg daily improve hirsutism and acne. Serum cortisol should be monitored.

### Antiandrogens

**Cyproterone acetate:** A synthetic antiandrogen drug such as cyproterone acetate, which has progestational as well as anti-androgenic and antigonadotrophic properties, can be used. It is widely used but is not always effective and hirsutism may recur after the therapy is stopped. For mild androgenic states, e.g. acne, it is given in a dose of 2 mg per day combined with ethinyl oestradiol. This serves the dual purpose of regularising the menstrual cycle as well as preventing conception during therapy as it is teratogenic. In severe cases of hirsutism with PCOS

it is given in a dose of 50 to 100 mg from day 5 through 16; ethinyl oestradiol is given from day 5 through 26 in a dose of 30 to 50 µg. The maximum dose of cyproterone acetate is 300 mg per day.

**Spironolactone:** This mineralocorticoid antagonist has a beneficial effect on hirsutism without serious side-effects but is ineffective for the other signs of virilism. It acts by competitive inhibition of dihydrotestosterone at the intracellular receptor level, suppression of testosterone biosynthesis and increase in testosterone catabolism. It improves hirsutism when taken in a dose of 100 mg for 6 months but side-effects include menstrual irregularity, nausea, fatigue, scalp hair loss, mastodynia and urticaria. A contraceptive must be used because of the possible risk of feminising a male foetus. Its use for the treatment of hirsutism has not been approved in the USA and UK.

**Flutamide:** This is a nonsteroidal antiandrogen which is a weak inhibitor of testosterone biosynthesis. It can be added to oral contraceptives when patients do not show any benefit with the latter alone. It is administered in a dose of 250 mg tds. Side-effects include dry skin, hot flushes, decreased libido, breast tenderness, fatigue, nausea, dizziness and hepato-toxicity.

**Finasteride:** This is a new follicular 5 α-reductase inhibitor currently under evaluation. It is administered in a dose of 5 mg daily. Finasteride can cross the placenta.

### Cosmetic

This is indicated mainly in cases of hirsutism without a definite organic cause, and these comprise the majority. It is also often a necessary supplement to more definitive treatment. If the hair growth is slight, nothing more than bleaching may be required. Otherwise, the superfluous hair is best removed by means of a depilatory wax, a razor or pumice stone. After centuries of experience, men know that shaving is the most efficient method but women are prejudiced against it, often because they have heard tell that it encourages a stronger growth of beard; this is not true. Electrolysis is painful and leaves scars. Thermolysis and laser epilation give better cosmetic results. The new chemical depilatories (destroyers of hair) are, unlike the older ones, relatively harmless to the skin and can be useful. In the form of pastes or creams they commonly contain mercaptans as the active principle as these act in the presence of an alkaline material.

# CHAPTER 15

## Injuries

Foreign Bodies in the Genital Tract	251	Rupture and Perforation of the Uterus	260
Vaginal Burns	253	Broad Ligament Haematoma	261
Direct Trauma to Vulva and Vagina	254	Genital Tract Fistulas	261
Defective or Deficient Perineum	255	Acquired Atresia and Stenosis	
Complete Perineal Tear	256	of the Genital Tract	268
Laceration of the Cervix	257		

### FOREIGN BODIES IN THE GENITAL TRACT

#### Vagina

##### *Types and Sources*

An extraordinary variety of foreign bodies may be found in the vagina. Sometimes the patient knows that the object is there but is unable to remove it by reason of its size and shape, or deliberately neglects it. More often she is unaware of its presence, having forgotten it or not knowing that it has been inserted.

##### *Therapeutic Agents*

Packs and dressings of various kinds may be left in the vagina after operation or treatment. **Packs or swabs are most commonly left after taking cervical biopsy.** The swab used to wipe the urethral orifice, and thereafter to hold the labia apart, for the purpose of catheterization is easily overlooked and can slip into the vagina. Instruments such as supporting pessaries can be retained for many years. Among primitive peoples nuts, seeds and plant leaves are put into the vagina for supposed medicinal effect. These have even been recovered from the peritoneal cavity, having presumably reached it through the posterior fornix or through the uterus and tubes.

##### *Contraceptive Devices*

These include sponges, occlusive caps, and even condoms which have slipped off without the woman's knowledge during coitus.

##### *Articles Inserted by the Patient or Entering Accidentally*

Under this heading all manner of household utensils are recorded - glass jars, serviette rings, tin cans and metal piping. **Sticks can also be found sometimes**

**embedded in the vagina.** In these cases the patient is often mentally deranged or sexually perverted.

Children insert toys, sweets, hairpins and the like into the vagina and do so mainly out of curiosity. Accidental inclusions such as small stones and fragments of clothing are found in baby girls.

#### *Instruments for Inducing Abortion and Labour*

Laminaria tents, bougies and catheters have all been left behind. The instruments of the criminal abortion-ist are even more likely to be lost or overlooked.

#### *Articles of Toilet and Hygiene*

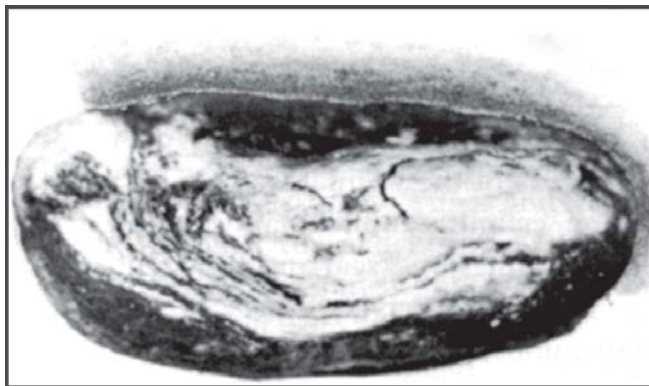
The most important example under this heading is a forgotten menstrual tampon; douche nozzles have also been found in the vagina.

#### *Vaginal Calculus*

Stone formation in the vagina is exceptional but occurs under two conditions: in an accessory ureter or a diverticulum of the urethra; or around a foreign body such as suture material or cotton wool (Fig. 15.1).

#### *Effects*

The effect of any object varies with its nature and shape. Articles made of rubber are very irritant; those made of inert materials such as plastic, porcelain and man-made fibres may cause little trouble. Cotton and woollen fabrics



**Fig. 15.1:** A vaginal stone, 4 cm in length, passed spontaneously from a bed in the lateral wall of the vagina. It contains a nucleus of fabric material the origin of which is not easy to understand. The only operation which the woman concerned had had was laparotomy for ectopic pregnancy 23 years previously. (Mr H. H. Francis' case)

quickly lead to local infection and a stinking discharge. Perforation, abrasion, pressure necrosis and local vaginitis result in ulceration of the vaginal walls; this can involve neighbouring structures to cause urinary and faecal fistulae. Infection may spread to produce salpingitis and peritonitis. Sometimes the foreign body becomes embedded with the vaginal wall closing over it. Carcinoma of the vagina is a late sequel.

In all cases the predominant symptom is an offensive discharge which is often bloodstained.

#### *Treatment*

The foreign body must be removed. This may be easy although, in young children, some form of narrow lighted endoscope is required. In certain cases where the article is sharp or of unusual size and shape, or where the lower vagina has undergone senile contracture, there is considerable difficulty and general anaesthesia may be required. Once the foreign body is removed, the vaginal wall heals by itself although cleansing and antiseptic douches help to reduce the odour and to clear up the infection more quickly.

### **Uterus**

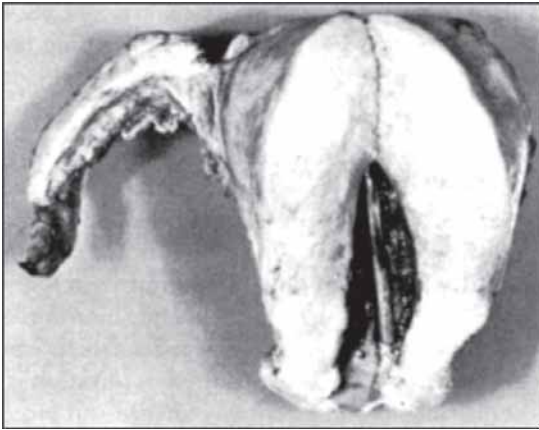
#### *Types and Sources*

Foreign bodies may remain in the uterus after operations. Sometimes gauze packs are deliberately inserted by the surgeon and their subsequent removal overlooked. Sometimes the woman herself inserts an object with the idea of preventing or terminating pregnancy.

One patient who had intractable uterine bleeding was ultimately treated by hysterectomy; a match stick, presumably inserted by the woman herself, was found in the uterus (Fig. 15.2). **Rarely an IUCD may be found years after insertion. The most common forgotten IUCD is the Lippes loop which on occasion has been first detected in hysterectomy specimens (there have been instances of IUCD insertion particularly immediately postpartum without the patients knowledge. Sometimes because of sheer convenience of the device, the patient may conveniently forget the presence.**

#### *Effects*

Mechanical irritation of the endometrium leads to infection, ulceration and possibly to cancer. Leading



**Fig. 15.2:** A match stick in the uterus of a woman, aged 32 years, treated by hysterectomy for 'dysfunctional uterine bleeding'. She probably inserted it as a means of contraception. The patient was previously treated by curettage twice and even had abdominal hysterotomy carried out without any foreign body being found. (Mr C.H. Walsh's case)

symptoms are menorrhagia, discharge and dysmenorrhoea.

#### Treatment

The diagnosis usually depends on the history and investigations, such as ultrasound, hysteroqram or hysteroscopy. Once the object is known to be present it can usually be removed with forceps or with a small blunt hook after dilating the cervix. Occasionally an embedded object may require hysteroscopy-guided removal.

#### Other Organs and Tissues

Sometimes an object alleged or known to have been inserted cannot be found in the vagina or uterus. Leaving aside the special problem of the displaced intrauterine contraceptive device, the likely sites for foreign bodies are the bladder, or the broad ligament and the peritoneal cavity which are entered through a tear in the vaginal fornix or in the wall of the uterus. Cystoscopy, laparoscopy, ultrasound and radiography are indicated in these circumstances. A foreign body in the female bladder can sometimes be palpated bimanually and can often be removed through the urethra using an operating cystoscope. One in the peritoneum may be retrievable by means of a laparoscope.

Instruments and needles broken during operation are more often lost in the tissues of the cervix or of the perineum. A *perineal sinus* after perineorrhaphy often has unabsorbed suture material as its root. This is rarely seen nowadays with the use of delayed absorbable sutures.

### VAGINAL BURNS

#### Causes

Vaginal burns can be caused by the following:

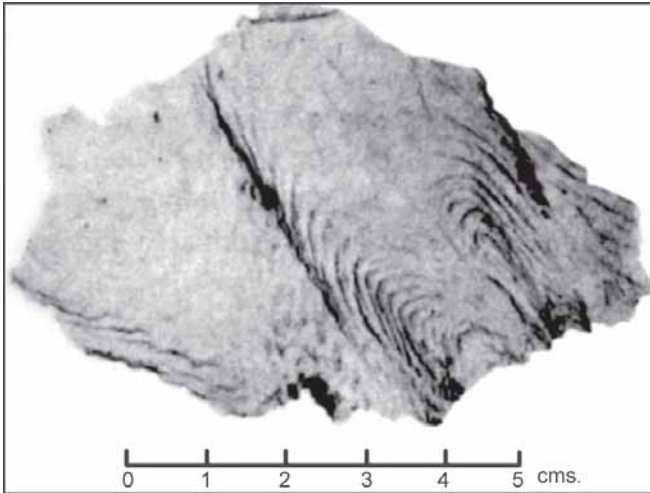
- Douching with fluid of too high a temperature
- Clumsiness and errors in using the electric cautery, diathermy, cryoprobe or laser
- Chemicals. Burns result from: an idiosyncrasy on the part of the patient to antiseptics and contraceptives; in the past, douching with too strong a solution of preparations containing cresols and phenols (Fig. 15.3); or the deliberate insertion of caustics. Potassium permanganate tablets and crystals have an unwarranted reputation as abortifacients and extensive punched-out ulcers of the vagina result from their use. In Arab countries the ritual placing of rock salt into the puerperal vagina causes severe chemical burns. The object of this practice is said to be the restoration of the vagina to its nulliparous dimensions.
- Radium and deep X-rays.

#### Effects

The effects vary from relatively innocuous superficial burns to extensive lesions resulting in denudation of large areas of the vaginal wall (Fig. 15.3), deep ulceration, cellulitis and fistula formation. Healing can lead to adhesions, scarring and stenosis of the vagina and adjacent cervix. Sequelae to these include haematocolpos and obstructed labour.

#### Treatment

Rest in bed is important for resolution of the inflammation; douches with warm saline solution or applications of an emulsion of acriflavine in liquid paraffin may also help. Instillations of hydrocortisone ointment offer the best means of limiting tissue reaction and fibrosis. Residual scar tissue may require dilatation or plastic surgery.



**Fig. 15.3:** A piece of vaginal epithelium which sloughed following a self-administered douche of a strong antiseptic solution

## DIRECT TRAUMA TO VULVA AND VAGINA

### Abrasions from Clothing

See chapter 20.

### Cuts and Lacerations

#### Accidents

Cuts and lacerations of the vulva and vagina are frequently sustained in accidents involving fractures of the pelvis or falling and sitting on sharp objects. They may also result from careless use of instruments during obstetric manoeuvres and during attempts to induce abortion. Adjacent structures such as the urethra, rectum, bladder and pouch of Douglas may also be involved. Treatment usually consists of cleansing the damaged tissues under general anaesthesia, immediate suture and the prophylactic administration of antibiotics. In certain circumstances antitetanus serum may be indicated. Where young children are concerned, surgical access to the upper vagina can be very difficult.

Rupture of the posterior vaginal fornix is also reported as a consequence of an accidental forced 'douche' resulting from a fall during water skiing. Girls and women engaging in this sport should wear a strong vulvar protective.

#### Coitus

Tearing of the hymen is almost inevitable with defloration and is sometimes accompanied by a small tear in

the fourchette. These generally cause slight bleeding which ceases spontaneously. Occasionally a rather large vessel is torn and can bleed so profusely that the woman becomes exsanguinated to the extent of requiring blood transfusion. Such bleeding can ordinarily be controlled by keeping the patient recumbent and by applying direct pressure to the bleeding point. If these measures do not stop the bleeding, then ligation or suture is often necessary. Rough coitus (including rape) can result in serious tears involving the perineum, vaginal wall, bladder and rectum. These are most likely in young virgins and in old women with atrophied tissues; the subject may be drunk and insensitive at the time. Coital rupture of the vaginal vault is seen particularly after total hysterectomy and can include the pelvic peritoneum to cause shock, prolapse of intestines and peritonitis. Such injuries require immediate investigation under general anaesthesia to determine the extent of the damage; they are treated by primary repair according to the findings.

#### Spontaneous

Rupture of the posterior fornix, or of the post-hysterectomy vaginal vault, involving the peritoneum above, can also occur spontaneously, being precipitated by a violent increase in intra-abdominal pressure during straining or coughing. It happens in old women with atrophic tissues.

The effects and treatment are similar to those described above.

#### Childbirth

Some degree of laceration of the vaginal wall, perineum, vulvar skin and underlying tissues accompanies the delivery of 70 per cent of first babies. A special and rare form of circular tear, resulting in partial avulsion of the uterus from the vagina, is termed *colporrhexis*. The prevention and treatment of these injuries is covered by textbooks on obstetrics. Their after effects are considered below.

### Haematoma of the Vulva and Vagina

Haematoma formation can result from a knock or a fall but is mostly seen in connection with childbirth. In the latter circumstance it can arise spontaneously to become manifest either during labour or within a few hours or days after labour. Vulvar and vaginal varicosities are said to predispose to this lesion but they did not play a part



in any of the cases which I have seen. The source of the bleeding is usually arterial.

The commonest cause of vulvovaginal haematomas is inadequate haemostasis during closure of tears and incisions. A deep-seated paravaginal haematoma can also be a complication of pudendal nerve block.

A vulvar haematoma presents as a painful, tender, purple-coloured swelling but, when it lies deeper and there is no skin bruising, it can be mistaken for a Bartholin's gland tumour. A low paravaginal haematoma tracks to the vulva, a high one can spread upwards retroperitoneally. The direction of spread is determined by whether the bleeding occurs below or above the attachment of the pelvic diaphragm to the vagina. A retroperitoneal haematoma forms a tumour which is often palpable abdominally.

General systemic upset and shock out of all proportion to the blood loss are striking clinical features of most cases. I have seen several 'near deaths' as a consequence of inadequate suturing of obstetrical tears of the vagina.

Treatment is *urgent*. The tumour should be incised as soon as possible, the blood clot evacuated, bleeding arrested, and the cavity obliterated by careful suturing. Only if it is impossible to secure haemostasis should packing or drainage be employed, for this leads to prolonged convalescence and much scar formation. Conservative treatment is rarely wise, and then only when the haematoma is inaccessible.

## DEFECTIVE OR DEFICIENT PERINEUM

### Pathology

The tissues of the vulva, and especially of the perineum, have remarkable powers of healing and of resistance to infection. So obstetrical tears and incisions, if sutured accurately with scrupulous attention to haemostasis, usually heal readily and completely. *Bilateral* episiotomy, however, should never be performed; it results in ischaemia of the intervening tissue so breakdown of the suture lines is almost inevitable.

A defective perineum is the end result of an unhealed (often unsutured) obstetrical tear which involves the muscles of the perineal body and the overlying skin. Sometimes the skin remains intact and the original injury consists of subcutaneous tearing and overstretching of the muscles; this leaves them slack and atonic. In either

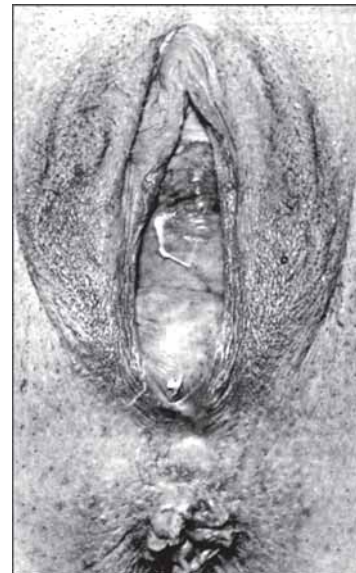
case the introitus gapes and the vaginal walls are exposed (Fig. 15.4). The weak perineal support favours the development of haemorrhoids and rectal prolapse but not of cystocele as is often supposed. The exposure of the vagina is said to increase the risk of vaginitis but in practice this does not occur.

### Symptoms

A deficient perineum is usually symptomless and, in a minor degree, may be a physiological outcome of labour, compensating for vaginal contracture in later years. Sometimes it gives rise to a feeling of pelvic insecurity when the woman is tired by standing. The atonicity can result in loss of sensation for both partners during coitus. Another possible symptom, and one causing great embarrassment, is *vaginal flatus* or *garrulitas vulvae*. The gaping introitus allows air to enter the vagina when the woman is in certain postures (for example, kneeling); this is then noisily expelled when the posture is changed. This symptom in minor degree is noticed quite commonly for a few weeks after delivery but usually disappears as the pelvic floor recovers tone.

### Treatment

No treatment is necessary unless symptoms are present. If they are, and they rarely are, treatment is by pelvic



**Fig. 15.4:** A defective perineum. A small rectocele is also present

floor exercises when the trouble is mainly muscular atony, and by posterior colpoperineor-rhaphy when there is gross anatomical deformity.

## COMPLETE PERINEAL TEAR

### Pathology

A third-degree (complete) obstetrical tear is one which involves skin, perineal muscles, and the *anal sphincter*. If it does not heal in the puerperium, the ultimate deformity is as shown in Fig. 15.5. The perineal body is absent in its lower part and the vaginal epithelium is continuous with the anal mucosa at the upper end of the defect. The external anal sphincter is only present posteriorly and is indicated by wrinkling of the skin. The torn ends of the retracted sphincter are marked by a dimple on each side (Fig. 15.6). The absence of sphincteric grip is revealed by inserting a finger into the anus.

### Symptoms

Despite the gross injury, many women remain surprisingly comfortable for many years by learning to use the levator ani muscle as a sphincter. The main problem for them is *the involuntary escape of flatus*.



**Fig. 15.5:** A complete perineal tear sustained during a delivery several years previously. The puckering of the skin denotes that the anal sphincter is intact posteriorly, its torn ends being marked by a depression on either side. Through the tear in the sphincter and in the anal canal, the bowel mucosa is bulging as a red mass, here appearing dark in colour

Incontinence of faeces usually occurs only when the motions are fluid.

### Treatment

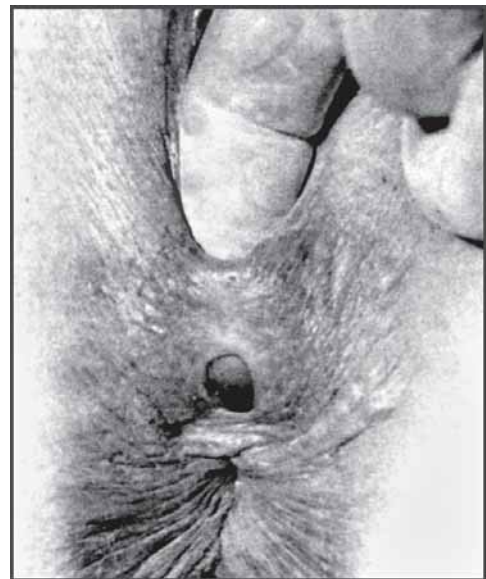
In the long-standing case treatment need not be instituted unless the patient has symptoms.

*The standard repair operation* consists of dissecting the vagina free from the rectum and identifying the ends of the anal sphincter. The tissues are then sutured together in the following order: rectal and anal mucosa from above downwards; anal sphincter; vaginal wall from above downwards; levatores ani muscles; superficial perineal muscles; and perineal skin.

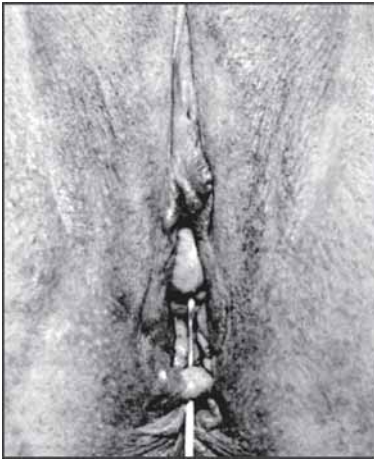
This type of operation can be carried out immediately after the injury is sustained; or from 3 to 6 months after delivery when involution is complete and the baby is weaned.

*Other procedures* applicable to cases in which there is much loss of tissue, or in which the standard operation has failed, include: using a flap of posterior vaginal wall to fill the defect in the anterior wall of the bowel; and advancement of the anterior rectal wall to a lower level.

Whichever procedure is adopted, the preoperative and postoperative care are important.



**Fig. 15.6:** A complete perineal tear which has partly healed, leaving a vaginoperineal fistula, and scar tissue in place of the anterior fibres of the anal sphincter. The dimples at the sides of the fistulous opening denote the retracted ends of the torn and sphincter. (Mr K. Baker's case)



**Fig. 15.7:** A complete perineal tear, the healing attempt of which resulted only in a fibrous bridge which created an anovaginal fistula. The sound has been passed through the anus beneath the bridge

## Results

The results of the standard repair operation, performed at the right times (*see above*), are generally satisfactory although anatomical success does not always mean perfect sphincteric control, especially during an attack of diarrhoea.

## LACERATION OF THE CERVIX

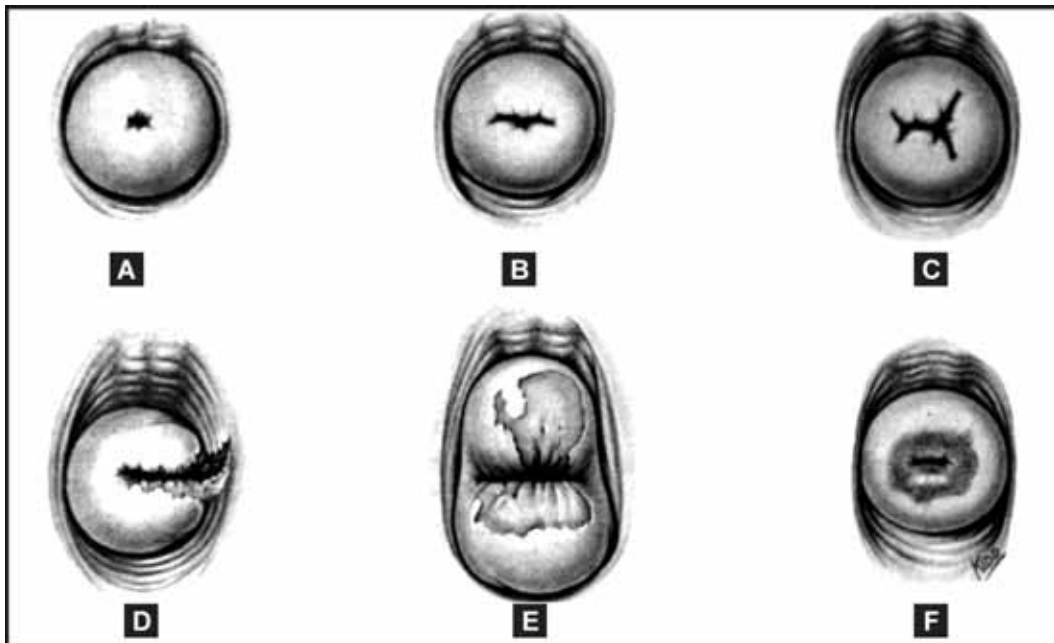
### Types and Causes

#### *Obstetrical injuries*

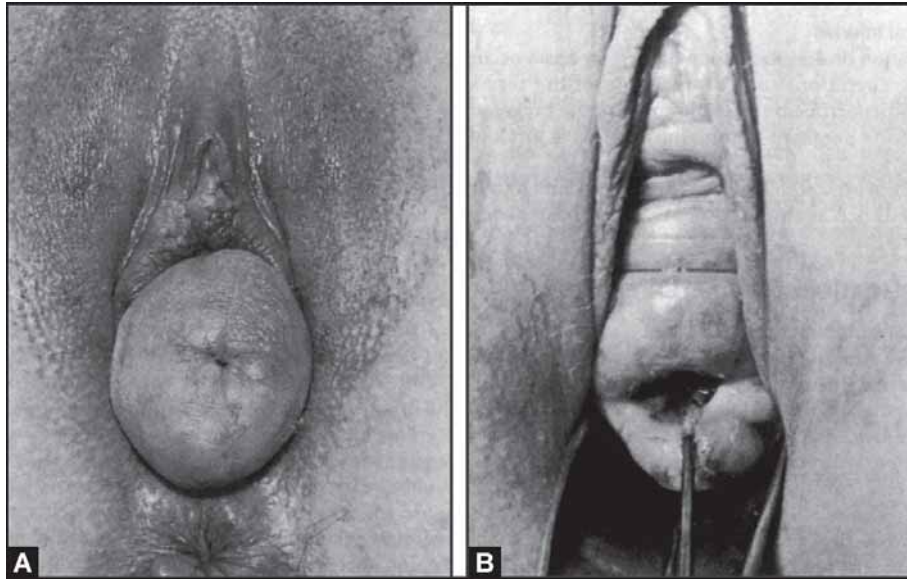
There is always some degree of physiological tearing of the cervix during childbirth and this explains why the multiparous external os is typically a transverse slit (Fig. 15.8B).

Pathological tearing of the cervix during labour is caused by: delivery by forceps, ventouse or breech extraction before the cervix is fully dilated; manual or instrumental dilatation of the cervix - *accouchement force*; precipitate labour, either spontaneous or as the result of the giving of oxytocic drugs; and failure of the cervix to dilate by reason of an inherent fault, scars dating from a previous operation or obstetrical injury, or disease.

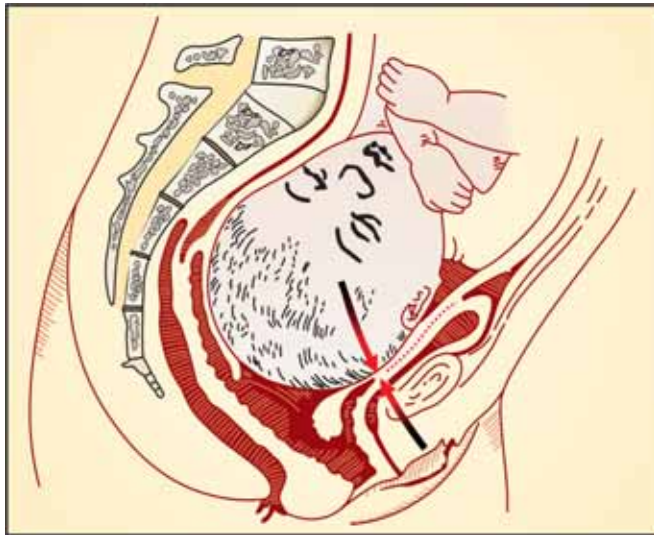
Cervical tears usually occur in the axis of the cervix and may be: *unilateral*, more commonly on the left side than on the right; *bilateral*; or *multiple* giving rise to a *stellate external os* (Fig. 15.8C). A lateral tear can extend so deeply as to open the base of the broad ligament, and to involve the lower uterine segment to produce an incomplete rupture of the uterus (Figs 15.8D and 15.9B).



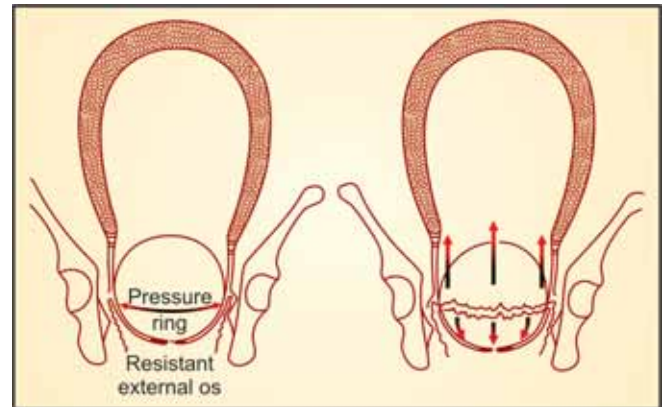
**Fig. 15.8:** (A) Normal nulliparous cervix (B) Normal multiparous cervix (C) Stellate laceration (D) Lateral tear extending into vaginal fornix (E) Ectropion of the cervix (F) Erosion of the cervix



**Figs 15.9A and B:** (A) A nulliparous cervix, easily seen because it is prolapsed, (B) A multiparous cervix, showing the typical scars resulting from old obstetrical tears. The tearing is three-pronged, the one on the left being deep and extending into the vaginal fornix



**Fig. 15.10:** The mechanism whereby the anterior lip of the cervix first becomes oedematous and then sloughs from ischaemia during labour. (By permission of the Editor, *J Obstet Gynaecol Br Emp*)



**Fig. 15.11:** The mechanism of annular detachment of the cervix during labour complicated by cervical dystocia. The foetal head fits tightly on to a thinned-out cervix and ischaemic necrosis occurs and below the pressure ring. Separation is completed by retraction of the uterus acting against the downward thrust of the presenting part. (By permission of the Editor, *J Obstet Gynaecol Br Emp*)

Rare obstetrical injuries include:

- Detachment of a part of the cervix, usually the anterior lip which becomes imprisoned between the presenting part and the symphysis pubis (Fig. 15.10).
- Annular detachment of the vaginal portion of the cervix (Fig. 15.11); this occurs during long labours in which the external os refuses to dilate — cervical dystocia.

- Cervicovaginal fistula formation. This results from the birth of the baby through the wall of a sacculated cervix instead of through the external os.
- **If a cervical stitch applied for an incompetent cervix is not removed and the patient passes in labour, the stitch may cut through or even an annular detachment of the cervix can occur.**

In the production of these lesions ischaemic necrosis from prolonged pressure plays a greater part than does direct trauma. These lesions are seen less often nowadays because of earlier resort to caesarean section in such cases. A characteristic tear seen in women in whom mid-trimester abortion is induced with prostaglandin  $F_{2\alpha}$  is the bucket-handle tear. As the name suggests, part of the cervical rim is detached. This can be prevented by adequate cervical ripening.

### Surgical Injuries

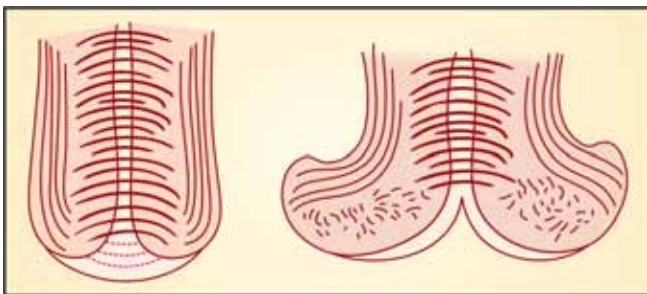
Perforation or deep laceration of the cervix can occur during operations such as dilatation of the cervix for dysmenorrhoea, and exploration of the pregnant or recently pregnant uterus whose cervix is soft and friable. **A volsellum can sometimes cause a nasty tear in the cervix which on rare occasions may even require stitching.**

Other surgical injuries include those deliberately inflicted such as amputation of the cervix and cone biopsy.

### Complications and after Effects

#### Cervical Ectropion

Bilateral vertical laceration of the cervix disrupts the connective tissue and circular fibromuscular fibres, leaving the longitudinal fibres of the external cervical



**Fig. 15.12:** The mechanism whereby ectropion occurs, following bilateral tearing of the circular muscle fibres in the cervix. The external longitudinal muscle then retracts unopposed

muscle free to act unopposed. The effect is to curl the lips of the cervix upwards and outwards to produce a condition of *ectropion* (Figs 15.8E and 15.12). The red-looking endocervix then becomes exposed so the condition is confused with erosion. Many ectropions are apparent rather than real, the observer being deceived by the fact that a bivalve speculum can pull open the lips of the cervix by its drag on the adjacent vaginal walls.

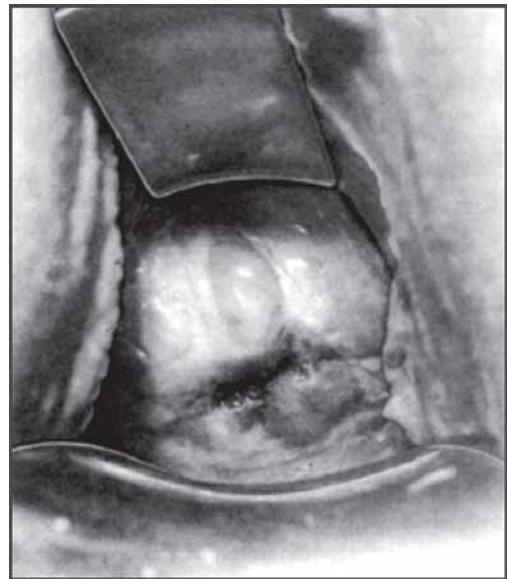
#### Distortion and Scarring of the Cervix

This is seen to some extent following all injuries but is most obvious when a tear has involved the vaginal fornix and when there has been actual loss of tissue (Fig. 15.13).

### Clinical Features

At the time of the injury and immediately afterwards no symptoms arise unless the tear opens a large blood vessel to cause haemorrhage, external or into the broad ligament; or unless it extends so high as to constitute rupture of the uterus; or the cellular tissue of the broad ligament becomes infected.

Here we are mainly concerned with the condition as seen at a later date and, again, *a lacerated cervix is usually symptomless*. When symptoms are present they are the



**Fig. 15.13:** The scarred stump of the cervix remaining 4 years after spontaneous annular detachment during prolonged labour. The patient concerned complained of infertility dating from delivery. (By permission of the Editor, *J Obstet Gynaecol Br Emp*)

result of: an associated cervicitis and cellulitis; tearing of the internal os causing abortion and premature labour; or partial or complete destruction of the vaginal cervix causing infertility, with or without stenosis of the canal (Fig. 15.13).

On examination the injury is usually obvious. As a rule it feels worse than it looks because underlying scar tissue and fixation are only appreciated by the tactile sense.

### Treatment

Cervical lacerations recognized at the time of their occurrence are sutured immediately. If found at a later date, no treatment is indicated in the absence of symptoms. The possible lines of treatment are described in chapter 20.

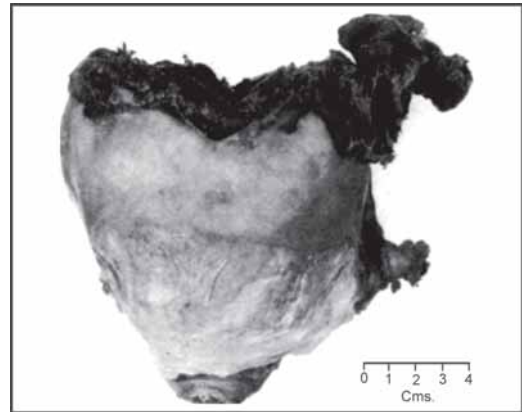
## RUPTURE AND PERFORATION OF THE UTERUS

Rupture and perforation of the uterus maybe *complete* or *incomplete*. A complete rupture involves all coats including peritoneum; an incomplete rupture leaves the peritoneum intact and generally has less serious consequences.

### Rupture

Spontaneous rupture of the non-pregnant uterus is described as a rare complication of haematometra and pyometra due to any cause. It is more likely if the uterus is senile as well as overdistended. The non-pregnant as well as the pregnant uterus can be ruptured by an extension of a cervical tear during operative dilatation of the cervix. During pregnancy the uterus ruptures as a result of:

- Severe direct violence
- Weakness of the wall resulting from old scars (Fig. 15.14). The most susceptible scars are those left after classical caesarean section (including hysterotomy), after injuries sustained in previous pregnancies (for example, perforation during curettage to complete or induce abortion), after reimplantation of the fallopian tubes, and after plastic operations on bicornuate uteri.
- Weakness of the wall due to abnormal invasion of the trophoblast (*placenta increta*).
- Abnormal thinning of the wall as found in sacculations, diverticula and rudimentary horns.



**Fig. 15.14:** Spontaneous rupture of the uterus at the thirty-sixth week of pregnancy. The rupture occurred at the site of the scar of a previous classical caesarean section, the incision at the time of this operation having to be placed in the fundus because the patient was a kyphotic dwarf. Following the rupture, which was not immediately diagnosed, the woman remained at home for 24 hours and, by the time she reached hospital, was desperately ill. She recovered after hysterectomy. The baby, lying free in the abdominal cavity, was dead

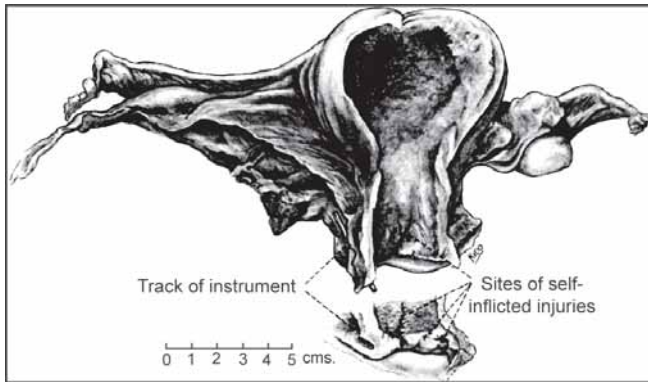
Rupture of the uterus in labour is outside the scope of this work.

Rupture of the pregnant or non-pregnant uterus causes severe lower abdominal pain which is usually followed by collapse due to intraperitoneal bleeding from the tear. If the rupture is incomplete a broad ligament haematoma results. Shock is not always present, or is slow to develop, if the rupture occurs through an avascular scar. The contents of the uterus - pus, blood or a conceptus - are extruded in part or whole, and produce peritonitis or peritonism.

After resuscitation the patient is treated by immediate laparotomy. The uterus is then repaired or removed according to the circumstances.

### Perforation

The uterus is easily perforated by a sound, a cervical dilator or a curette, or during the insertion of a contraceptive device, especially if there is difficulty in negotiating the cervical canal and if the uterus is retroflexed. The accident is more likely if the uterine wall is soft, friable or thin - as it is in pregnancy (Fig. 15.15) or immediately afterwards, in old age and when invaded by cancer.



**Fig. 15.15:** This drawing of a necropsy specimen dates back to the preantibiotic era. It shows a recently pregnant uterus with injuries to the cervix and a perforation into the left broad ligament which resulted from the criminal induction of abortion. The woman concerned died from puerperal sepsis

The dangers of perforation are haemorrhage and the dissemination of any infection or malignant disease which may be present. Moreover, if the accident is not recognized, the intestine may be injured. If the uterus is empty and the operation is a clean one, no harm results as a rule. If the perforation occurs during attempts at criminal abortion, or during the evacuation of a septic abortion, peritonitis or cellulitis is almost inevitable.

Treatment varies with circumstances but is guided by the following rules.

If the uterus is empty, laparotomy is usually unnecessary but if not, laparoscopy allows inspection of the uterus before and during removal of any remaining contents. Any spread of infection is counteracted by appropriate antibiotics.

Laparotomy is indicated if abdominal contents prolapse through the hole or if there is any likelihood of their having been injured before the accident was discovered; if there is a lesion such as cancer or pyometra in the body of the uterus; if laparoscopy reveals the perforation to be getting larger during evacuation; or if laparoscopy is not possible or practical and the uterus still contains products of conception. The uterus is then repaired or removed according to the circumstances.

## BROAD LIGAMENT HAEMATOMA

### Pathology

A collection of blood in the cellular tissues of the broad ligament is not common but is a serious condition. It can

form a large tumour which, if the bleeding is not arrested, spreads extraperitoneally into the space of Retzius and up the anterior or posterior abdominal wall. The haematoma is *nearly always unilateral*. If neglected, a broad ligament haematoma can become infected.

### Causes

- Haemorrhage from operation sites or from lacerations in the uterus, cervix and upper vagina. Incomplete haemostasis is a serious and not uncommon immediate complication of lower segment caesarean section; the resulting haematoma may be in the uterovesical space or in the broad ligament.
- Incomplete rupture or perforation of the uterus.
- Direct injury with a penetrating instrument.
- Haemorrhage from tumours of the uterus, fallopian tube, ovary or pelvic ligaments.
- Extraperitoneal tubal rupture of an ectopic pregnancy.
- Spontaneous haemorrhage. This is most likely to be seen following labour and especially when blood coagulation failure complicates abortion or *abruptio placentae*.

### Clinical Features

The general condition of the patient suggests the occurrence of internal haemorrhage. She complains of pain low down in one or other iliac fossa and shows varying degrees of shock. Mild pyrexia is the rule after the acute phase. Bladder irritability, retention of urine, diarrhoea and rectal tenesmus are common. The diagnosis is made by feeling a fixed tender swelling lying to one or other side of the uterus and *apparently continuous* with the uterus. It may be palpable abdominally as well as bimanually.

### Treatment

A large haematoma is evacuated through the vagina or by an extraperitoneal abdominal approach. The bleeding point is secured if possible and the broad ligament drained. A small haematoma can be left to become absorbed.

## GENITAL TRACT FISTULAS

Communications between the genital tract and the urinary or alimentary tracts may occur singly or in combination. Fistulas may be of various types.

## Vaginoperineal

A tract between the posterior vaginal wall and the perineum (Fig. 15.6) is usually the result of incomplete healing of an ordinary obstetrical perineal tear, but can be the sequel to the very rare condition of *central tear of the perineum*. It is usually symptomless and rarely requires treatment. If it causes symptoms it can be excised. Preoperatively a sinogram should be done. Intraoperatively injection of a dye, e.g. gentian violet into the sinus is useful; sometimes these fistulas can have wide ramifications in the perineum which are shown up by the dye and complete excision is then possible.

## Faecal

Faecal fistulas can be classified according to the level at which they open in the genital tract.

## Tubointestinal

This condition is mostly seen in association with a pyosalpinx, especially the tuberculous variety. The fistula may develop by spontaneous rupture of the pyosalpinx into the intestine, or it may arise as a result of attempts at surgical interference. A faeculent discharge through the uterus can ensue, but is unusual because the tube is likely to be closed.

## Uterointestinal

A communication of this kind usually involves the colon rather than the small intestine. The causes are malignant disease, diverticulitis, pelvic abscess and tuberculosis; the lesion is nearly always *primary in the bowel* rather than in the uterus.

A discharge of flatus and faeces through the cervix and vagina is the patient's complaint. The fistula can be demonstrated by hystero-graphy or a barium enema X-ray but extensive investigation is necessary to elucidate the underlying lesion. Treatment may involve hysterectomy and resection of the bowel.

## Vaginointestinal, Perineointestinal

It is usually the pelvic colon or the rectum which communicates with the vagina. Rarely, the small intestine communicates, usually in the case of malignant disease. An opening on the perineum links with the anus or lower rectum.

## Causes

### *Congenital Malformation*

Perineal or vaginal anus: incomplete partition of the cloaca (*see* page 216, Fig. 13.22).

### *Foreign Bodies (vagina, bowel or peritoneal cavity)*

These erode the mucosa and cause a perforation.

### *Obstetrical Injury*

The foetus itself, if its delivery is obstructed, can cause pressure necrosis of the rectum. Instruments used to assist its birth may perforate the vagina and rectum. The rectum may be included in a suture during repair of a perineal tear. The majority of obstetrical rectovaginal and perineoanal fistulas, however, represent the end results of incomplete healing of third-degree perineal tears (Fig. 15.7).

### *Operation Injury*

The rectum may be opened during total hysterectomy, or during any of the many operations which involve puncture, incision or dissection of the posterior vaginal wall and fornix. If the injury is not recognized and successfully repaired, a fistula results.

### *Extension of Disease*

Any pelvic abscess can open into both rectum and posterior vaginal fornix; an abscess secondary to diverticulitis may discharge through the vagina; a perianal abscess may burst onto the perineum. Tuberculosis and lymphogranuloma inguinale are other causes of rectovaginal fistulas. Carcinoma of the cervix is not by itself a common cause of a faecal fistula because the pouch of Douglas intervenes between the cervix and rectum. Carcinoma of the vagina is more likely to be a cause but, unless the patient has had radiotherapy previously, a malignant rectovaginal fistula nearly always means a *primary lesion in the bowel*.

### *Radiotherapy*

Heavy irradiation of any type, and especially that delivered by megavoltage apparatus, may cause ischaemic necrosis of the bowel and lead to a fistula, usually with a stricture below it, 3 months to several



years after treatment. A combination of tumour and radiation reaction is one of the commonest causes of faecal fistulas.

### Clinical Features: Diagnosis

The complaint is incontinence of faeces and flatus. A large fistula is readily identified. A small one can be difficult to find and to track; the elucidation of its anatomy may require proctoscopy, sigmoidoscopy and observations on the behaviour of introduced radio-opaque and coloured fluids.

### Treatment

Some form of surgery is nearly always indicated but its type depends on the position and cause of the fistula. For an anoperineal fistula the best procedure is to lay open the track and allow it to granulate. When diverticulitis is the underlying cause of a rectovaginal fistula, resection of the affected portion of the bowel may be necessary. If the basis is a malignant state the choice may lie between exenteration and colostomy. It should be recognized, however, that the patient may prefer to have faecal incontinence through the vagina than through the abdominal wall. When cancer has been eradicated by radiotherapy, removal of all the vaginal epithelium and obliteration of the cavity (*colpodeisis*) can give good results (*see below*).

Some radiation fistulas, and nearly all traumatic ones, can be cured by careful dissection and suture of bowel and vagina, but success depends on *delaying the operation for 3-6 months* after the appearance of the fistula. All tissue reaction must be allowed to subside to offer easy dissection and good healing. A pinhole-sized traumatic fistula is readily closed but breaks down surprisingly often.

Most faecal fistulas opening into the vagina are best tackled through the vagina but a *very* high one, communicating with the upper rectum or the colon, may require an abdominal approach. I have seen a case where the rectum was accidentally opened while opening the peritoneum of the pouch of Douglas at vaginal hysterectomy. Although the surgeons recommended a colostomy, a primary direct closure was done and the patient did well.

A fistula which is the consequence of partial healing of a complete perineal tear, is best converted into a complete tear and then repaired as such.

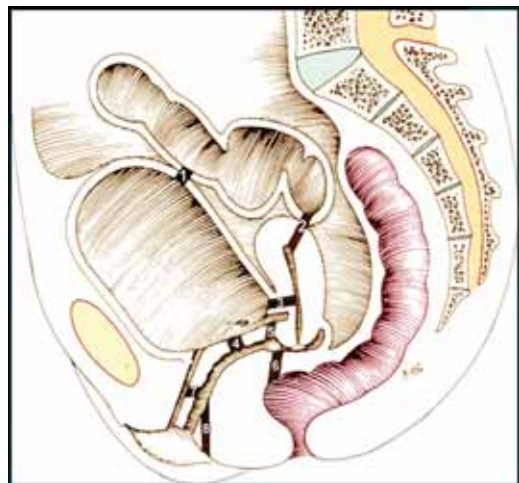
Only in exceptional cases is colostomy necessary as a preliminary to closure of the fistula. Otherwise, the preoperative and postoperative management is the same as for complete perineal tear.

### Urinary

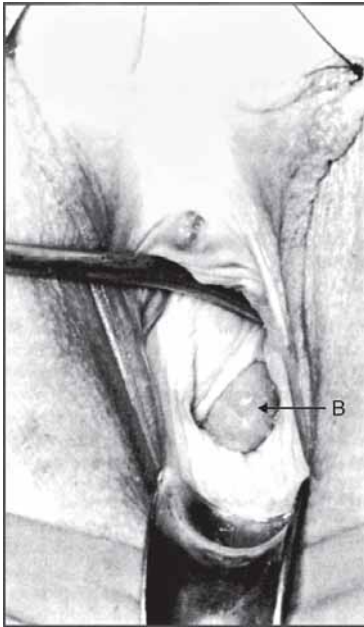
#### Types

Urine may escape into the genital tract from the ureter, bladder or urethra (Fig. 15.16). In the case of the first two, the communication may be with the uterus, cervix or vagina. Urethral fistulas always enter the vagina. The urethra may be completely destroyed or severed (Fig. 15.18). The commonest fistula is the vesicovaginal, the opening in the bladder being in the trigone near the middle line. It varies from a pin-head in size to complete destruction of the bladder base and urethra. When the opening is sufficiently large the bladder wall prolapses through it (Fig. 15.17).

Fistulas resulting from accidental, surgical and obstetrical trauma are produced in two ways. They can be caused by direct injury such as cuts and perforations and they then manifest themselves immediately by haematuria and incontinence. Alternatively, they are the outcome of pressure necrosis (including involvement of the tissues in a ligature), or of ischaemia; in such a case the hole does not develop and give rise to urinary incontinence *until 7-14 days after* the accident, operation or confinement.



**Fig. 15.16:** The commonest sites for fistulas: (1) vesicocolic; (2) uterocolic; (3) vesicouterine or vesicocervical; (4) vesicovaginal; (5) ureterovaginal; (6) rectovaginal; (7) urethrovaginal; (8) vaginoperineal



**Fig. 15.17:** A vesicovaginal fistula occurring as a complication of total hysterectomy. B - the mucosa of the bladder ballooning into the vagina. (Photograph presented by Professor Chassar Moir)

## Causes

### *Congenital Malformations*

Aberrant ureter and persisting urogenital sinus.

### *Accidents*

Crush injuries to the pelvis, becoming increasingly common as a feature of road accidents, can cause perforation of the bladder and urethra by bone fragments, or avulsion of the urethra.

### *Operative Injury*

This is the commonest cause of urinary fistulas in the West. One analysis from the USA put the causes as: pelvic surgery 45 per cent, cancer with or without radiotherapy 34 per cent, obstetrical trauma 15 per cent. Of fistulas coming to operation, 70 per cent are gynaecological and 30 per cent obstetrical. This is to be contrasted with the situation in tropical Africa and most developing countries where 85-95 per cent of the very numerous urinary fistulas are obstetrical.

In nearly all gynaecological operations one or other part of the urinary tract is in danger.

The ureter is at risk in total hysterectomy, especially radical hysterectomy, and during the removal of broad ligament tumours. It can be damaged at the pelvic brim during division and ligation of the infundibulopelvic ligament; it is sometimes lifted up and divided during the dissection of adnexal masses fixed in the floor of the pelvis or at the lateral pelvic wall. The lower ureter is at risk during vaginal hysterectomy and prolapse repair operations.

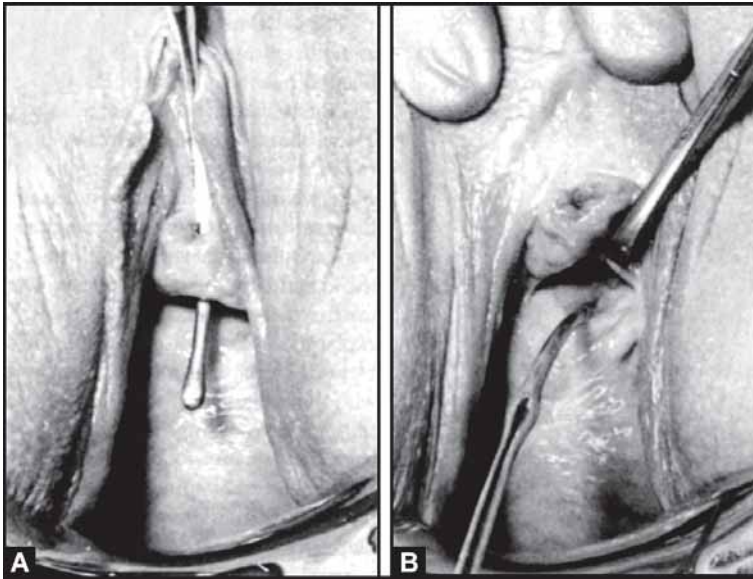
The bladder is liable to injury during total hysterectomy and during all operations involving the anterior vaginal wall. I have seen a vesicovaginal fistula caused by placement of sutures through the bladder base when the vaginal cuff was sutured. The sutures could be seen at cystoscopy!

The bladder dome can also be injured while opening the abdominal cavity, especially if there is a previous incision and scarring. With the use of laparoscopy in recent years for hysterectomy, colpourethropy, etc. endoscopic bladder injury has also been reported, especially in patients with prior pelvic surgery and endometriosis.

The urethra is threatened during anterior colporrhaphy and sling operations in particular.

### *Obstetrical Injury*

In developing countries, obstructed labour is a common problem for a variety of reasons. Women are economically underprivileged, illiterate, married early and have poor access to family planning and medical services. Teenage pregnancy is common and antenatal care unavailable to the vast majority of women in rural areas. Women with cephalopelvic disproportion or malpresentations may be in prolonged obstructed labour which leads to ischaemic vascular injury from compression of the soft tissues between the foetal head and maternal pelvis. Ischaemic tissue necrosis leads to the development of a genitourinary fistula in the puerperium, usually after 7-10 days. The fistula resulting from pressure during long and difficult labour always involves the trigone of the bladder which is nipped between the presenting part and the back of the symphysis pubis. This proves that the bladder is *not* lifted into the abdomen—an old belief which many are reluctant to discard. The lower end of the ureter, the bladder base and the urethra may be directly injured by instruments. Forceps rotation of the foetal head is a particular threat (Figs 15.18A and B).



**Figs 15.18A and B:** Complete division of the urethra 1-2 cm above the external meatus, which was caused by a difficult forceps rotation and delivery of a woman's first baby. She did not suffer incontinence of urine because the defect is well below the internal sphincter. On the contrary, her complaint was attacks of retention caused by contracture of the scar tissue at the lower end of the upper segment of urethra. She was successfully treated by periodic dilatation of the upper urethra without anaesthesia being necessary, (A) The lower end of the urethra leads into the vagina, (B) The fibrosed false meatus within the vagina

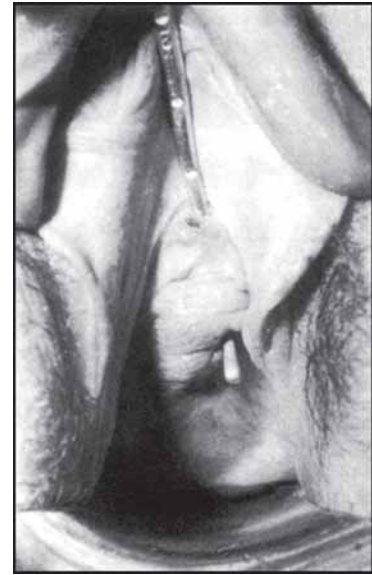
During lower segment caesarean section, the bladder base may be torn, rendered ischaemic or included in a suture to result in a fistula which usually communicates with the uterus or the cervix. When haemorrhage from tears at the angles of a transverse lower segment incision requires ligation of the main branches of the uterine vessels, the ureters are at risk. Rupture of the scar of a previous lower segment operation can implicate the adherent bladder base.

#### *Extension of Disease Processes*

Carcinoma of the cervix and vagina, acting alone or in conjunction with radiotherapy, is one of the commonest causes of vesicovaginal fistula but the growth itself rarely invades the ureter. Genitourinary tuberculosis and schistosomiasis are rare causes of urinary fistulas.

#### *Radiotherapy*

Excessive, misapplied and even well-applied irradiation for carcinoma of the cervix causes a vesicovaginal fistula



**Fig. 15.19:** A fistula between the vagina and the upper urethra resulting from an injury sustained during anterior colporrhaphy. This caused continual urinary incontinence because it involved the internal sphincter. The fistula was successfully closed and the internal sphincter tightened with restoration of continence

in the same way as it causes a rectovaginal fistula by ischaemic necrosis. It is therefore a late complication, sometimes taking several years to develop.

#### **Clinical Features and Diagnosis**

True incontinence caused by a fistula has to be distinguished from *urethral incontinence*. When there is a fistula the urine escapes continuously, day and night. If the patient never needs to void, it signifies that the fistula communicates with the bladder. If, however, the bladder fills and empties as well, it suggests a fistula into one ureter.

Unless they involve the upper half including the internal sphincter, urethral fistulas give little trouble because the urethra is normally empty of urine (Fig. 15.19). However, during micturition urine passes through the fistula and may then fill the vagina to dribble away during body movement for a short time afterwards.

Mid-vaginal fistulas may be located below the interureteric ridge. These are usually caused by a misplaced radium applicator or anterior colporrhaphy, but sometimes may also be the result of difficult forceps delivery.

High fistulas usually include the anterior cervical lip. They may be obstetrical or radiation-induced. Fistulas following hysterectomy are also high at the vault. These fistulas are supratrighonal and the margins may be very close to the ureteric origin.

Large fistulas may be seen in which most of the anterior vaginal wall has been destroyed. The pubic bone may also be exposed. Conversely, sometimes the defect can be difficult to find if it is small. The complaint of true incontinence is so typical as to leave little doubt as to the existence of a fistula. In such cases examination in the knee-chest position can be helpful because air then enters the bladder and bubbles through the hole when the woman coughs. Another test is to place three large pledgets of cotton wool in the vagina, one above another, and to run methylene blue solution into the bladder (3-swab test of Moir). If only the lowest swab stains, the fistula is urethral; if the middle or upper swabs stain, the fistula is vesical; if none of the swabs stains but the upper one is wet, the fistula is ureteric.

Every case needs investigation to determine the exact position of the fistula, and the anatomy and function of the rest of the urinary tract, before treatment is planned. The minimum requirements are examination of the urine, pyelography, cystoscopy and renal function tests.

Those women who have already had an unsuccessful operation for closure of a fistula involving the bladder may have intravesical stones and phosphate deposits with a nucleus of unabsorbed suture material. These should be removed at least 6 weeks prior to repair to allow inflammation to settle.

A remarkable feature of vesicovaginal fistulas, even those with concomitant rectovaginal fistulas, is that they are almost never complicated by cystitis, and this despite the ready pathway which they provide for the entry of organisms. Although this might be explained by the continual ebb of urine to leave the bladder empty, it should shake the belief of those who think that all women are cystitis-prone because the shortness of their urethras allows easy ascent of bacteria.

Most vesicovaginal fistulas are painless but radiation fistulas are associated with severe pain. A biopsy from the margin of the fistula is recommended to rule out persistent or recurrent disease.

### *Menouria*

A rare but interesting syndrome is one in which a uterovesical fistula causes haematuria at the times of

menstruation, the patient remaining free from urinary incontinence. The whole of the menstrual discharge may occur via the urethra. The presence of the fistula can be demonstrated by hystero-graphy but not by cystography. This syndrome is seen when the fistula (usually following caesarean section) opens into the uterus above the isthmus. The latter is assumed to prevent any cervical outflow of urine by its sphincteric action.

### Treatment

The woman with a constant dribble of urine is in a miserable plight with contaminated and smelly clothing and vulva, the latter becoming excoriated. Protective pads and waterproof underclothing are of little avail. So the woman shuns all social contacts and, in turn, is shunned by friends and relations. She not uncommonly develops secondary amenorrhoea, this presumably reflecting a subconscious and strong desire to arrest any sort of outflow from the vagina. In these cases menstruation becomes reestablished as soon as the fistula is cured.

All this emphasizes the need for efficient treatment, the principles of which are as follows.

#### *Conservative Treatment*

This is worthwhile for *recently formed* fistulas. A ureteric leak may cease of its own accord. A vesico-vaginal fistula sometimes closes if the bladder is drained continuously for 3 weeks to 3 months, the patient meanwhile being kept in the prone or Sims' position. This latter treatment has been tried even if a fistula has been present for several months and is recorded as being successful after years of incontinence. Such fistula repairs, however sometimes break down a few weeks later. If conservative treatment fails, surgery on the following lines is indicated. It has been the standard practice as in the case of faecal fistulas, to defer any reconstruction operation for 3-4 months after the initial injury, or after a previous attempt at repair, to allow all tissue reaction to subside.

However, with small, non-complicated fistulas an earlier repair can be planned within 1-8 weeks and has been shown to be curative in 80 per cent of patients. Those who fail to heal can undergo a second, usually successful repair 6-8 weeks later. Although success rates with the standard delayed method are in the range of 95-98 per cent, this method of early repair allows for an overall decrease in the number of wet days and greater

patient comfort. Proper selection of cases is essential. Postirradiation fistulas may take 6 months to 2 years to be ready for repair. Very rarely, some small vesicovaginal fistulas less than 3 mm in diameter have been treated with superficial bladder fulguration using electrocautery or laser. However, there should be no history of previous attempts at repair and the vesicovaginal septum should not be too thin, otherwise the fistula size can increase with considerable scarring of the margins.

#### *Surgery for Ureteric Fistulas*

Here the possibilities are repair of the ureter; transplantation of the upper cut end into the bladder or into a rolled flap of bladder (Boari operation); replacement of the defect by a loop of ileum; ureteric diversion into the colon or the formation of an ileal conduit; or sacrifice of the ureter and kidney. The last is to be avoided if at all possible.

#### *Surgery for Uterovesical Fistulas*

This often requires an abdominal operation. The usual operation is to identify the fistulous tract, suture the uterine and bladder defects in layers and interpose the vesical peritoneum. A hysterectomy is required if the fistula is large. If the patient has some degree of cervical descent and the fistula is low, a vaginal repair may rarely be possible.

#### *Surgery for Vesicovaginal Fistulas*

Preoperative cystoscopy helps to evaluate the size and location of the fistula and its distance from the ureteric orifices; accordingly the repair can be planned. Ureteric catheterisation before repair prevents their encirclement with a suture or obstruction by postoperative oedema if the ureters are close to the fistula margin. Unless the loss of tissue is very extensive nearly all these fistulas can be closed by dissection and suture from the vaginal aspect. The results are usually better than those obtained by a transvesical approach. The operation is one for an expert who is prepared to modify the technique to suit the individual case. Adequate dissection and mobilisation of tissues, excision of the fistula tract and all scar tissue, and good haemostasis are essential for a successful outcome. Synthetic, delayed absorbable polyglactin or polyglycolic acid sutures (3-0) are used nowadays. The first row of sutures in the bladder is the most important.

This is tested with methylene blue, reinforced if necessary and followed by a second covering layer in the muscularis, broad surface to broad surface without tension. The vagina should also be closed without tension, and not necessarily perpendicular to the bladder sutures. In fact, the least tension is usually in the transverse direction.

Simple posthysterectomy vesicovaginal fistulas at the vaginal vault can be closed vaginally by Latzko's partial colpocleisis after ureteral catheterisation. The transperitoneal transvesical approach is reserved for the following situations: the fistula margins are close to the ureteric orifices; an omental flap is to be used; ureteroneocystostomy is required; bladder patching or augmentation with sigmoid colon, ileum or caecum is to be done. Problems of fistula exposure can often be managed by a Schuchardt incision. It is important to avoid suturing tissues under tension. Wherever there is excessive loss of tissue with inadequate mobilization, a graft can be employed. The Martius graft using the bulbocavernosus pad of muscle and fat may be used in vaginal repairs. It is a simple procedure and I have always had gratifying results. It leaves an asymmetrical vulva with a scar, but I have never seen any patient complain, such is her relief after successful surgery! In abdominal repairs, the omentum can be interposed between the layers. Other autografts which have been used include peritoneal flaps, gracilis muscle and rectus abdominis flap. The ischaemia which prevents radiation fistulas from healing may be overcome by living muscle transplants.

An important part of treatment is the aftercare; it is essential to keep the bladder empty by continuous suction drainage for 2 or 3 weeks. This is generally arranged by way of the urethra but, in the case of fistulas involving the urethrovesical junction, supra-pubic cystotomy is often preferable. Adequate fluid intake is essential to ensure a high output of dilute urine and prevent catheter blockage. The output should not be less than 50 ml/hour, and outputs of 100 ml/hour are not uncommon.

Some patients may continue to have incontinence after adequate healing. This may be due to scarring at the bladder neck and anatomic alteration of the normal relationship of the bladder neck and upper urethra, or to a dyssynergic detrusor muscle with a small bladder capacity.

### *Surgery for Urethrovaginal Fistulas*

When the urethra is destroyed a new one can be created by turning in a U-shaped vaginal flap to form a tube, or by other specialized technique. A Martius graft is used in cases with deficient tissues. The ordinary urethrovaginal fistula, however, can usually be closed by layer suturing after wide dissection. The easiest and most successful technique for this is first to divide the floor of the urethra from the external meatus up to the site of the fistula (Figs 15.20A to D). This permits good exposure. Again, after these operations the bladder needs to be drained continuously for at least 14 days.

### *Surgery for Complicated Fistulas*

The term 'complicated fistulas' includes those which are very extensive, those that have had unsuccessful attempts at repair, combined fistulas involving the urethra, vesical neck or ureters, postradiation or post-malignancy fistulas and those associated with intestinal fistulas. In these cases, additional special techniques may be necessary. The combined transvaginal-transvesical-transperitoneal approach may be used. Grafts, as described above, are used more often to allow better support and neovascularisation.

Fistulas characterized by gross loss of tissue are sometimes best circumvented by transplantation of both ureters into an isolated loop of ileum or into the colon. A colonic implant is now generally avoided unless the expectation of life is in any case short; the creation of a ureteroileocolostomy is preferable. Exenteration may be indicated occasionally, especially when active malignant disease is still present. When it is not, however, large radiation fistulas, including those in which both the bladder and the rectum communicate with the vagina, can be successfully managed by *colpocleisis*. In this operation, the defect is covered with a flap of vaginal skin and the remainder of the vaginal wall is completely removed; the resulting cavity is then obliterated and the introitus closed. In the case of combined fistulas this may still leave a communication between the bladder and the rectum but this is so planned that the flow of contents is from bladder to rectum and not vice versa.

Sometimes, the operation may need to be done in stages when traumatic or postradiation vesico-vaginal and rectovaginal fistulas are present simultaneously, the rule is to do a preliminary colostomy. The fistulas are

then closed, sometimes at the same sitting but sometimes the vesicovaginal fistula first and the rectovaginal fistula later. When the fistulas have healed, the colostomy is closed.

### *Prevention of Fistulas*

Improvement in obstetric care will reduce the incidence of fistulas in developing countries: prevention of teenage pregnancy, access to antenatal care, use of the partogram, timely referral and caesarean section where necessary.

In gynaecological practice, dissection of the bladder is very important. Sharp dissection is preferable to blunt dissection, especially in cases with previous surgery like caesarean section or Fothergill's operation. In cases of severe endometriosis or pelvic inflammatory disease, it may be necessary to visualize the ureter to ensure its safety. Sometimes it may be wiser to perform a subtotal hysterectomy when the danger of removing the cervix is greater than that of leaving it in.

Early recognition and appropriate repair of injuries is an important feature of prevention. Ideally, the injury should be recognized intraoperatively by seeing urine spurt into the field or by instilling methylene blue diluted with sterile saline into the bladder in high-risk cases.

In the postoperative period, abdominal pain, distention, paralytic ileus, haematuria or dysuria should point to the possibility of bladder injury. Patients with ureteric damage or ligature may have flank pain and an unusually hectic postoperative period.

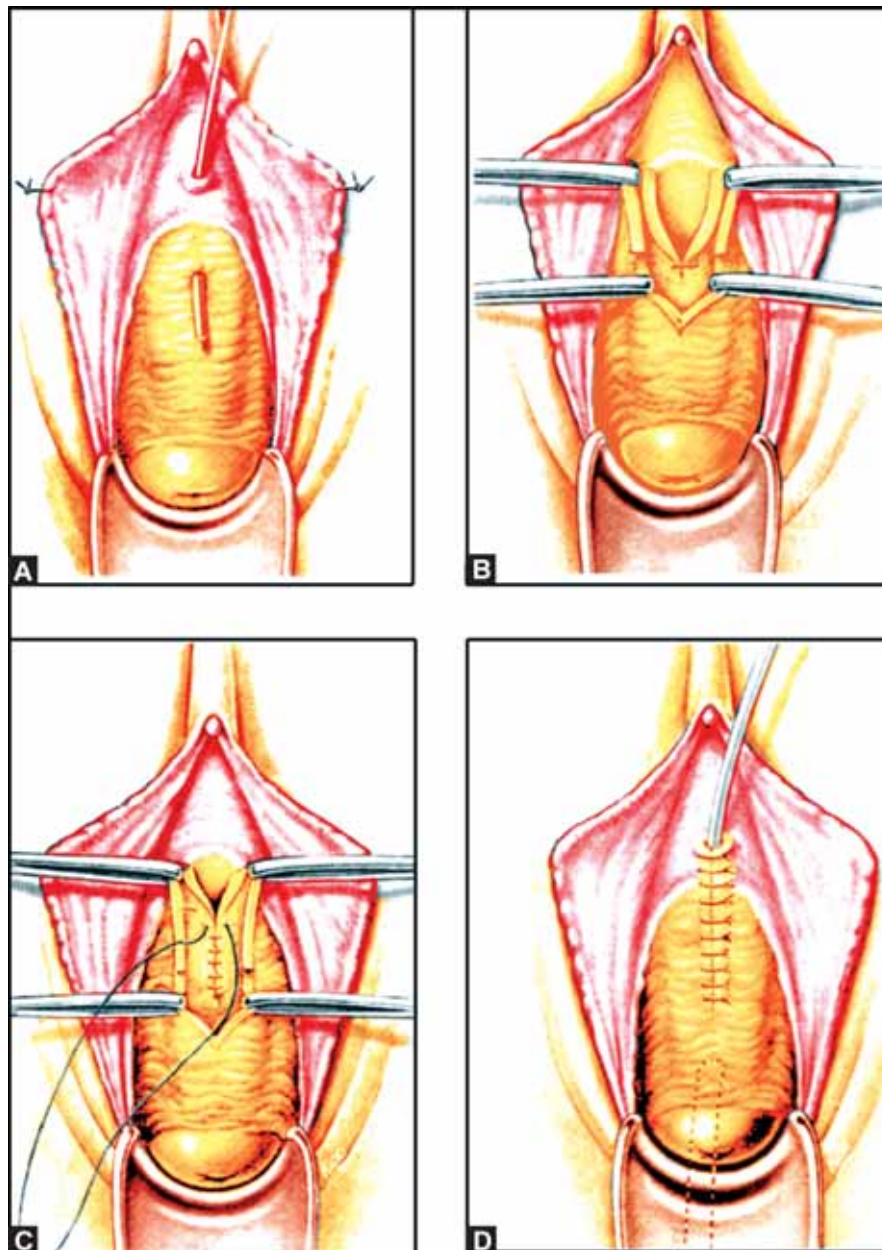
### **Pregnancy after Cure of Vaginal Fistulas**

If a woman conceives after cure of a urinary or faecal fistula communicating with the vagina, it is usually wise to deliver the baby by elective classical caesarean section. This does not always apply after the closure of a rectovaginal fistula which was part of a complete perineal tear. Episiotomy in labour protects this sort of operation scar.

### **ACQUIRED ATRESIA AND STENOSIS OF THE GENITAL TRACT**

#### **Pathology**

Trauma or disease can result in complete or partial obstruction, narrowing, adhesions and strictures in any part of the genital tract (gynatresia).



**Figs 15.20A to D:** A technique for the repair of a urethrovaginal fistula which gives better results than mere local dissection and closure of the track. It ensures good exposure, easy dissection and accurate closure in layers, (A) Fistula defined with a sound, (B) The floor of the urethra is divided from the external meatus up to and including the fistula. The vaginal wall is then widely freed from the urethra, the dissection being carried higher than the opening to permit tightening of the internal sphincter above, (C) Closure of the urethra is from above downwards. Only one row of sutures is shown but two are desirable. During the closure the lumen can be protected by a polythene tube of small bore, (D) The vaginal wall is now closed and a catheter placed in the urethra to provide continuous drainage for at least 14 days. Alternatively, drainage for the same period of time can be provided

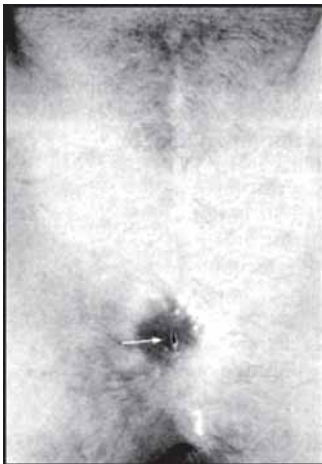
## Causes

### Senility

Contracture of the introitus and vagina is the inevitable accompaniment of senile atrophy, although it is controlled to some extent by regular coitus. If infection is superimposed, adhesion formation is likely and this is seen particularly around the clitoris (Fig. 15.21) and in



**Fig. 15.21:** Senile contracture of the introitus in a woman aged 72 years. It is unlikely to cause any symptoms other than dyspareunia



**Fig. 15.22:** Stenosis of the vulva following repeated partial vulvectomy for recurrent Paget's disease. The opening to the vestibule appears only as a black spot (arrow). The skin around appears dark because in life it was red. The stenosis ultimately caused retention of urine and had to be dealt with by a plastic operation. The woman in this case ultimately died from previously unrecognized cancer of the cervix. She had been seen regularly for many years but the stenosis precluded vaginal examination and cervical cytology

the upper vagina (*adhesive vaginitis*). Stenosis of the cervical canal is another possible manifestation of senility.

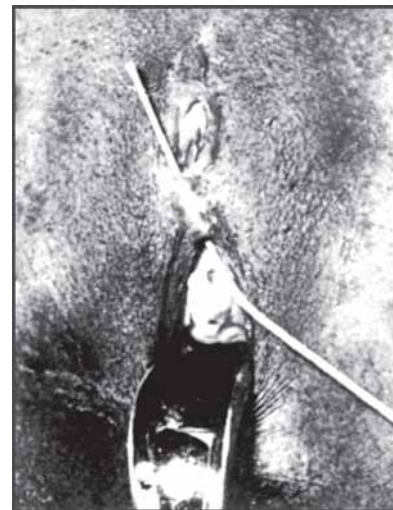
## Operative and Other Injuries

### Vulva

Stenosis is commonly caused by overenthusiastic perineorrhaphy. After both simple and radical vulvectomy, contracture can be several enough to obstruct the outflow of urine (Fig. 15.22). Burns, obstetrical and accidental injuries, *female circumcision* and *infibulation* practised by certain African tribes can all lead to gross distortion and bizarre adhesions (Figs 15.23 and 15.24). These ritual procedures are carried out in infancy or childhood to reduce erotic sensation and protect virginity. In circumcision the clitoris and surrounding tissue is crudely excised. Infibulation involves the additional removal of the foreparts of the labia to leave raw areas which are then fastened together. The resulting obstruction to the introitus may later have to be divided to permit consummation of marriage.

### Vagina

The vagina can become stenosed, closed or the site of adhesions as a result of burns, lacerations and operations especially if infection is superimposed. In the treatment of prolapse in old women, the surgeon often deliberately narrows the vagina. In colpocleisis he obliterates it.



**Fig. 15.23:** Adhesions and distortion of the vulva of a Somalian woman, resulting from ritual circumcision in childhood





**Fig. 15.24:** The result of ritual circumcision or infibulation in childhood, as seen in a woman from Southern Egypt. The clitoris and the labia minora, except for a remaining fragment on the left side, have been removed and there is considerable scarring over the pubes

Unintentional obstruction of the vagina after colporrhaphy operations is sometimes due to the formation of adhesions between the incisions on the anterior and posterior walls. These are easily broken down 2 or 3 weeks after operation but, if overlooked at that time, become firm fibrous bands.

#### *Cervix*

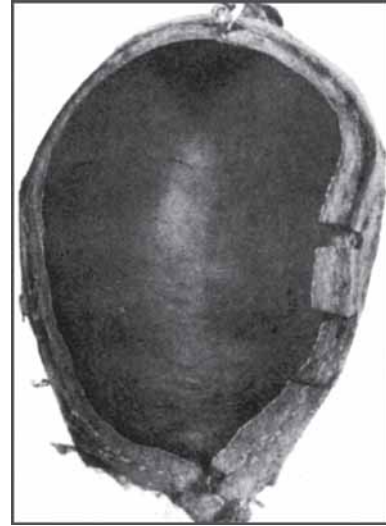
The commonest injuries causing stenosis of the cervix are amputation and excessive cauterisation. Cone biopsy does not usually result in stenosis. It is more likely to leave the cervix incompetent or so fibrotic that it fails to dilate in a subsequent labour. Patients who have undergone transcervical resection of the endometrium may develop stenosis which responds well to simple dilatation.

#### *Corpus Uteri*

Partial or complete obliteration of the cavity of the uterus is a rare sequel to brutal curettage in the presence of infection, and to any form of cauterisation.

#### *Fallopian Tube*

The tube may be divided or ligated during operation.



**Fig. 15.25:** Haematometra associated with stenosis of the cervix which followed the introduction of radium to induce the menopause

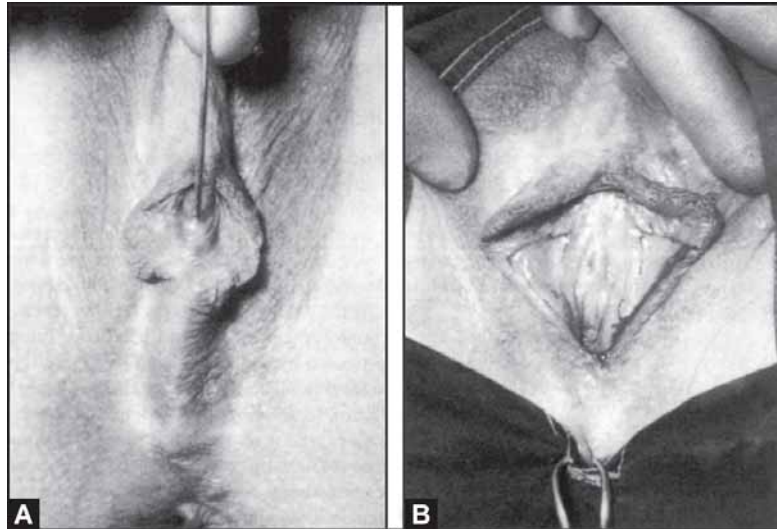
### Radiotherapy

Radium and caesium are potent agents in causing cervical and vaginal stenosis and closure. A menopausal dose may be followed by haematometra and pyometra (Fig. 15.25). A cancericidal dose of radium or caesium and X-rays almost always results in closure, not only of the cervix but also of the upper vagina; unless the patient uses dilators regularly immediately post radiotherapy; this does not often cause trouble, however, because menstrual function is suppressed simultaneously. A collection of blood in the uterus often means a recurrence of active growth.

### Infections and Epithelial Disorders

#### *Vulva*

Closure of the introitus can result from chronic infections such as tuberculosis, granuloma inguinale and lymphogranuloma. It is seen as a complication of chronic vulvar epithelial disorders. Non-specific vulvitis in old women can lead to adhesions between the labia minora but when *adhesive vulvitis* is found in the adult it can date back to infancy, having been overlooked during the years (Figs 15.26A and B). Adhesive vulvitis or *agglutination of the labia minora* (and the condition has several other names) is not uncommonly encountered in babies. The initial inflammation generally passes



**Figs 15.26A and B:** Closure of the adult vulva by adhesion of the labia minora. The patient concerned was aged 47 years, married 11 years, nulliparous and unaware that the marriage had never been consummated. She complained of postmenopausal bleeding for one year and, despite her virginity, was found to be suffering from a Stage III squamous cell carcinoma of the cervix. It seems likely that the adhesions had been present throughout life, or at least since childhood when their cause could have been vulvitis. (A) Introitus closed except for the tiny opening anteriorly through which the woman urinated and menstruated; the occluding membrane is demonstrated by lifting it with a sound, (B) The membrane, consisting of no more than adherent labia minora divided to reveal a normal vulva and introitus. The line of adhesion is indicated by the fine dark line of blood

unnoticed, or is not regarded as significant, but it raws the edges of the labia minora which then stick together in the middle line, leaving only a small opening anteriorly or posteriorly for the escape of urine (Figs 15.27A and B). If this is hindered, dysuria or general soreness of the vulva can lead the child to attract the mother's attention to the vulva. In at least one-third of the cases, however, the condition is symptomless and the mother discovers it incidentally. She usually concludes that the deformity is congenital and the medical attendant may also think likewise. One maternal diagnosis is absence of the vagina. By the time medical advice is sought the baby is likely to be 1-3 years old.

#### Vagina

Vaginal adhesions and contracture occur as a result of granulomatous conditions, senile vaginitis and secondary infection of injuries.

#### Uterus

Partial or total obliteration of the uterine cavity and intrauterine adhesions (*synechiae*) are complications of

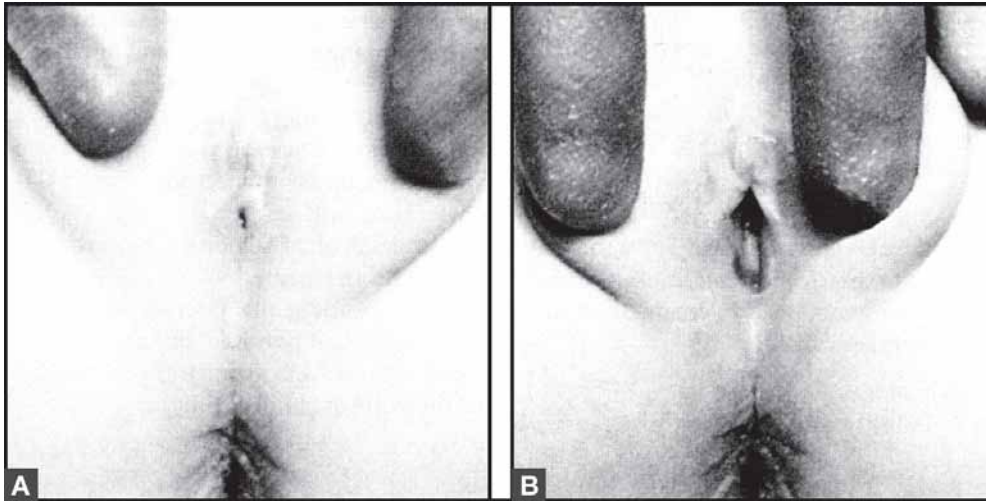
postabortal infections and tuberculous endo-metritis. Overzealous curettage can lead to this situation by removing even the basal endometrium. If the diagnosis is suspected, it can be confirmed by hysteroscopy. Adhesions may be thin, flimsy and easily broken by the hysteroscope itself; thick and fibrous, a fleshy and vascular. They can also be categorized according to the extent of cavity they occupy and whether the ostia are visible or not.

#### Fallopian Tube

Infection of any type is the main cause of tubal obstruction but endosalpingiosis can also operate (*see* Chapter 22).

#### Tumours

Benign tumours of the vulva, vagina and uterus distort the genital canal but they do not narrow it. Thus cysts, polyps and leiomyoma in the cervix never hold back the menses. Malignant growths, however, commonly obstruct; two of the commonest causes of pyometra and haematopyometra are carcinoma cervix and carcinoma corporis.



**Figs 15.27A and B:** Adhesive vulvitis in infancy, (A) The vulva of a child aged 3 years with closure of the introitus except for a tiny opening through which the girl passed urine. This abnormality is commonly assumed by the mother to be congenital but it is usually if not always the result of previous and often unrecognised vulvovaginitis. (B) Separation of the labia minora along the line of adhesion reveals a normal vestibule, urethra and vagina within

### Effects

These naturally vary with the site and extent of the obstruction, with the age of the patient and with other circumstances.

#### *Retention of Discharge*

The hold-up of menstrual blood causes haematocolpos, haematometra and haematosalpinx. Partial retention, as seen sometimes with stenosis of the cervix causes spasmodic dysmenorrhoea. Other possibilities are hydrocolpos, pyocolpos, hydrometra, pyometra, hydrosalpinx and pyosalpinx.

When the uterine cavity is obliterated, or most of the endometrium destroyed (*Asherman's syndrome*, see Chapter 37), the symptom is amenorrhoea and not cryptomenorrhoea.

#### *Apareunia and Dyspareunia; Infertility*

Coital problems arise only when the lesion affects the vulva or vagina. Obstruction at any level interferes with conception.

#### *Dystoda*

Stenosis of the cervix, vagina and vulva, or failure of these tissues to stretch and dilate, causes obstructed labour. If the obstruction is overcome by tearing, severe haemorrhage can occur.

#### *Urinary Symptoms*

Bladder irritability and retention are caused by haematocolpos and pyocolpos. Closure of the vulva can be so extensive as to cause retention of urine, dysuria or dribbling (Fig. 15.22).

### Treatment

Obstruction of the vulva, vagina and cervix can be treated by separation or incision of adhesions, excision of membranes, dilatation under anaesthesia or by plastic surgery according to circumstances. The subsequent local application of an acriflavine in liquid paraffin dressing, or of a corticosteroid preparation, daily for 14 days helps to prevent recurrence of the trouble. Agglutination of the labia in infancy may be treated by simple incision or

digital separation under general anaesthesia, keeping them apart with a lanoline dressing for 1-2 weeks afterwards. This gives excellent results but is said to be unnecessary in that the labia can, in 90 per cent of cases, be persuaded to fall apart spontaneously merely by the regular application of an oestrogen ointment for 2-4 months.

Uterine adhesions can be broken down with cervical dilators and a curette if they are flimsy, or they can be divided under direct vision at hysteroscopy, using flexible or semi-rigid scissors, the monopolar needle electrode or the Nd:YAG laser. Postoperatively the uterine cavity may be held open with a small intrauterine

contraceptive device (IUCD). The other alternatives are: the insertion of a Foley catheter into the uterine cavity and distension of the balloon with gradually increasing volumes of fluid (up to 20 ml) during the next 1-2 months; and the administration of oestrogen and progestogen, alone or in conjunction with insertion of an IUCD or the catheter treatment.

Obstruction of the fallopian tube causing infertility.

Sometimes the genital tract above the level of the obstruction is best removed; this applies particularly to haematometra and pyometra occurring in women past the years of childbearing.

# CHAPTER 16

## Pelvic Organ Prolapse

Uterine and Vaginal Prolapse	275
Prolapse of the Ovaries	292

Pelvic organ prolapse refers to protrusions of the pelvic organs into or out of the vaginal canal.

### UTERINE AND VAGINAL PROLAPSE

*Prolapse, procidentia* (from the Latin *procidere*, to fall) or downward descent of the vagina and uterus is a common and disabling condition. Vaginal prolapse can occur without uterine prolapse but the uterus cannot descend without carrying the upper vagina with it.

#### *Supports of Uterus (Figs 16.1A and B)*

Apart from the normal position- anteverted anteflexed there is a three tier system consisting of the following:

- Upper
- Middle (strongest and important)
- Lower

#### *Upper Tier*

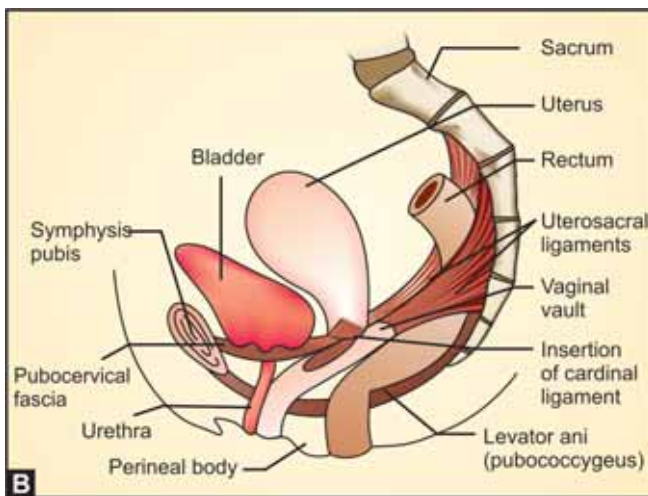
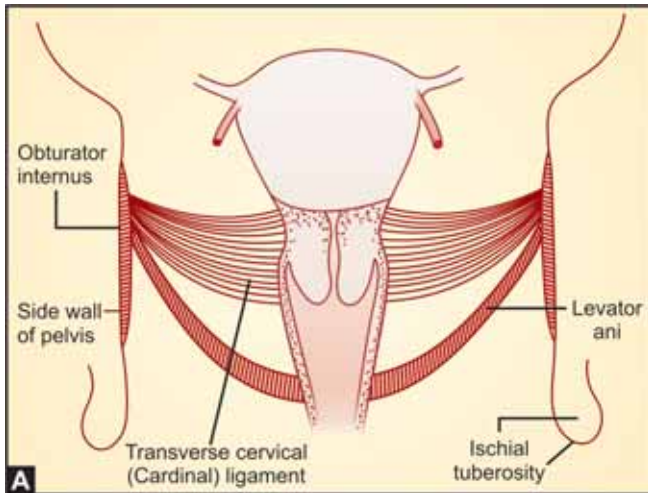
- Weak
- Mostly by maintaining the uterus in anteverted position
- Endopelvic fascia
- Round ligaments
- Broad ligaments with intervening pelvic cellular tissues

#### *Middle Tier*

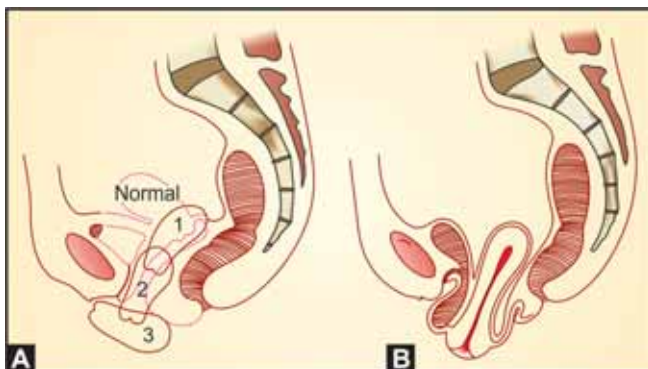
- Strongest support of uterus
- Cervico vaginal junction
- Pelvic cellular tissue

#### *Inferior Tier*

- Indirect support to the uterus
- Principally given by the musculofascial tone of the hollow vagina which is amply supported by the fascial condensation at the vault and by the pelvic floor at the lower end.



**Figs 16.1A and B:** Different supports of uterus



**Figs 16.2A and B:** (A) Degrees of uterine prolapse, (B) The anatomy of second-degree uterine prolapse associated with cystocele and enterocele. A rectocele is not present. The supravaginal cervix is elongated

## Types

### Uterine (Uterovaginal) Prolapse

The pelvis may be said to consist of 3 compartments: the anterior, middle and posterior. Descent of the anterior compartment results in cystocele and urethrocele, that of the middle compartment in descent of the uterine vault and enterocele, and that of the posterior compartment in rectocele.

In order to descend, the uterus becomes slightly retroverted to lie in the axis of the vagina. When the prolapse is reduced, however, the uterus is often found to be anteverted. The imperfection of the grading systems are evident from the number of systems that have been developed over the years. Various classifications have been described. According to one scheme, three degrees of uterine descent are recognised (Fig. 16.2A).

*First degree:* Descent of the uterus but the cervix remains within the introitus.

*Second degree:* Descent to the extent that the cervix projects through the vulva when the woman is straining or standing.

*A third degree, i.e. complete procidentia or general prolapse:* The entire uterus prolapses outside the vulva. The whole vagina, or at least the whole of its anterior wall, is everted.

In Shaw's classification, descent is classified into four degrees - the first degree remains the same as above, but the second degree is one where the cervix descends to the level of the introitus; the third when it projects through the vulva; and the fourth degree is complete procidentia.

Baden's system of grading is similar to Shaw's but uses the hymen as a reference point. Each component is graded from 0 to 4 with the patient straining.

Urethrocele, cystocele, prolapse, rectocele

- 0 Normal
- 1 Descent to half way to hymen
- 2 Progression to hymen
- 3 Progression halfway through hymen
- 4 Maximal progression through hymen

Enterocele

- 0 Normal. Maximum of 2 cm of cul-de-sac between posterior cervix and rectum
- 1 Herniation of cul-de-sac to one-fourth of distance to hymen

- 2 Herniation to two-fourths of distance toward hymen
- 3 Herniation to three-fourths of distance toward hymen
- 4 Herniation to hymen

Chronic perineal laceration

- 0 Normal (no more than hymenal laceration)
- 1 Involvement of anterior half of perineal body
- 2 Involvement of perineal body but not anal sphincter
- 3 Involvement including anal sphincter
- 4 Involvement including anal mucosa

However, these systems do not provide accurate quantification for scientific comparison, lack reproducibility and specificity and may not accurately describe the structures associated with the sites of prolapse. To address these problems, the International Continence Society has therefore approved a new system, the Pelvic Organ Prolapse Quantification (POPQ) staging system, which measures in centi-meters the positions of 9 sites on the vagina and perineal body in relation to the hymen (Figs 16.3A and B). These 9 sites are as follows:

- Aa - located 3 cm proximal to the urethral meatus on the anterior vaginal wall;
- Ba - the most distal position of the upper anterior wall;
- C - the most distal edge of the cervix or vaginal cuff;
- D - the location of the posterior vaginal fornix;
- Ap - located 3 cm proximal to the hymen on the posterior vaginal wall;
- Bp - the most distal position of the upper portion of the posterior vaginal wall.

In addition, the diameter of the genital hiatus (gh), width of the perineal body (pb), and the total vaginal length (tvL) are measured and recorded on a grid form

(Fig. 16.3B). A final prolapse stage from 0 to 4 can be assigned according to the severity of the greatest degree of prolapse.

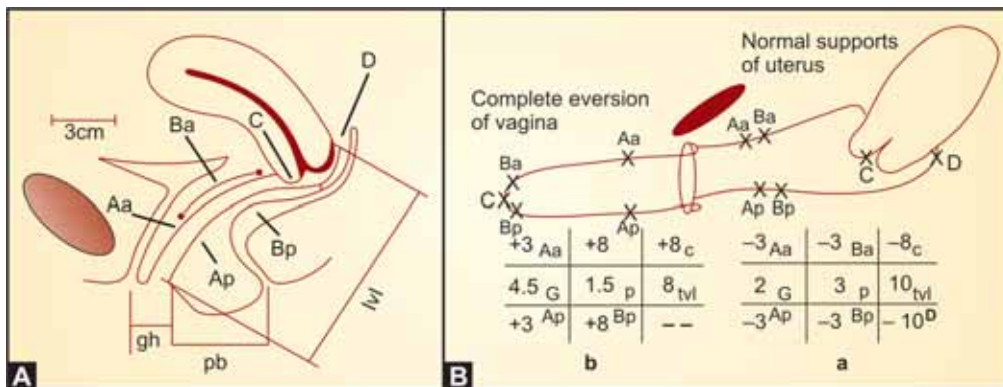
It is important to recognise that these measurements can change according to the position of the patient, e.g. standing or lithotomy, and by insertion of a speculum. It is also important to mention whether the patient was straining or whether traction was applied. Measurements at points gh and pb are completed first. A speculum is then placed in the vagina to allow introduction of a spatula and measurement of tvL. Points C and D are next measured during maximal valsalva effort. Lastly, points Aa, Ba, Ap and Bp are measured.

Complete procidentia is not common and many cases so diagnosed are really examples of severe second-degree prolapse. The mistake is made because elongation, hypertrophy, congestion and oedema of the cervix account for such a large protrusion of tissue as to make it appear that the whole uterus must be outside the vulva (Fig. 16.8). In fact, the uterus cannot escape from the introitus unless it remains small; when it does, a failure in *all* the genital supports is implied — a condition of *total or general prolapse*.

Vaginal Prolapse

Anterior Compartment Defects

The prolapse may involve mainly the upper or the lower anterior vaginal wall and, according to the structure underlying it, the condition is then termed cystocele or urethrocele (Fig. 16.4).



**Figs 16.3A and B:** (A) Graphic representation of points used to quantify prolapse (see text), (B) Line diagram showing contrasting measurements of normal supports (a) and post-hysterectomy vaginal eversion (b) International Continence Society Standardisation of Terminology of Female Pelvic Organ Prolapse and Pelvic Floor Dysfunction. (Reproduced with permission from Bump *et al.*, *Am J Obstet Gynecol*, 1996,175:12-14)

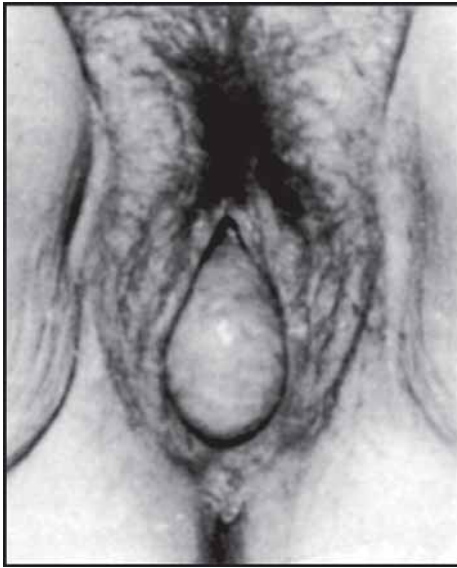


Fig. 16.4: Cystocele

In *cystocele*, the bladder base descends with the vaginal wall and ultimately forms a pouch which, when the patient strains, reaches a lower level than the internal urethral meatus (Fig. 16.10). The part distal to the interureteric ridge in the bladder is called an anterior cystocele and that proximal to it is called the posterior cystocele. Both types usually coexist.

An anterior cystocele represents a weakness in the support of the bladder neck, urethrovesical junction and proximal urethra, caused by weakness of the pubocervical fascia and the pubourethral ligaments. This weakness may be paravaginal, i.e. at the lateral

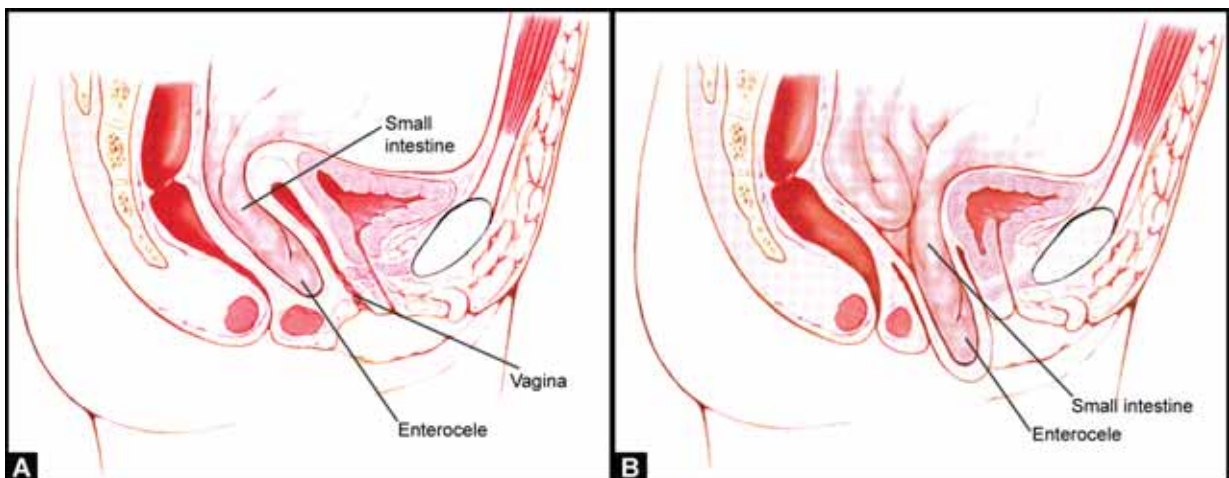
attachments of the pubocervical fascia to the pelvic side walls; transverse, i.e. where the pubocervical fascia blends into the pericervical ring of fibromuscular tissue in front of the cervix; central, i.e. above the vaginal mucosa in the midline; distal, i.e. where the urethra passes through the urogenital diaphragm. Combinations of these defects may occur. An anterior cystocele is commonly associated with genuine stress urinary incontinence because of the loss of the normal urethrovesical angle.

A posterior or true cystocele may be asymptomatic or may be noticed protruding through the vaginal introitus. If it is very large it leads to difficult or incomplete emptying of the bladder. It is not usually associated with genuine stress incontinence unless an anterior cystocele coexists.

In *urethrocele* the urethra is dislocated from the subpubic angle and is displaced backwards and downwards on straining. This lesion means damage to the triangular ligament which ordinarily fixes the urethra forwards; the urethra itself is not dilated. Radiologically, there is a resultant loss of the urethrovesical angle.

#### Middle Compartment Defects

This includes enterocele and massive eversion of the vagina. The enterocele (Figs 16.2 and 16.5) is a herniation of the pouch of Douglas which contains loops of small bowel, as the name suggests, or omentum. This is an important condition because if its correction is overlooked at the time of surgery, the patient may present with a recurrence of the prolapse.



Figs 16.5A and B: Uterine prolapse with an enterocele bulging behind a congested and oedematous cervix



Three types of enterocele are identified:

- *Pulsion enterocele*: The vaginal vault is pushed outward by conditions which increase intra-abdominal pressure, e.g. chronic respiratory problems, lifting of heavy weights, etc.
- *Traction enterocele*: A pre-existing weakness in the anterior compartment and uterine descent pull down the vault.
- *Iatrogenic*: This follows a vault suspension procedure or procedures such as Burch or Marshall-Marchetti-Krantz which produce a change in the vaginal axis and subject the vault to abnormal pressures.

Massive eversion of the vagina or vault prolapse may or may not exist with cystocele, rectocele and enterocele.

Patients with enterocele and vault prolapse present with backache, pelvic heaviness and pressure or a 'bearing down' sensation.

### Posterior Compartment Defects

Rectocele and perineal body descent are the main components of the posterior compartment defects. The importance of perineal body descent has been recognised as an additional component in the New York modification of the POPQ staging system.

Rectocele (Figs 16.6 and 16.7A and B) is caused by the weakening of the fibres of the rectovaginal fascia (Denonvillier's fascia). As with anterior compartment defects, it is important to assess the condition by



Fig. 16.6: A small rectocele

rectovaginal examination and in the erect position, if necessary, the exact location and type of defect, i.e. upper, mid or lower third of the vagina; linear or transverse.

Assessment of the levator plate by palpation between the two fingers inside the vagina and the thumb outside on the perineum is also an essential part of the assessment. Integrity of this plate is vital to maintaining the vagina in its correct position. *Adequacy of vaginal length so that its apex is well above the levator plate is essential for preventing recurrence of the prolapse.* The only exception to this rule is in the case of radical surgery where, despite a short vagina, prolapse is never seen. This is because of the extensive scarring which occurs around the vagina consequent to extensive tissue dissection.

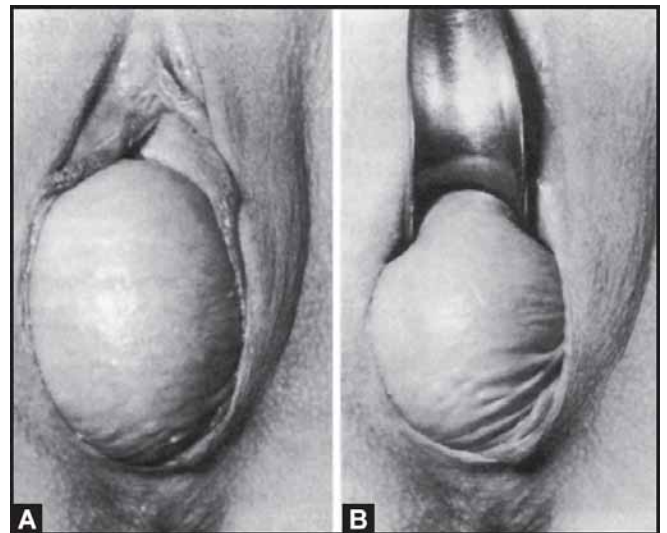
### Complications

#### *Keratinization of the Vagina*

The epithelium of the prolapsed vaginal walls and of the portio vaginalis, being constantly exposed to the air and possibly to trauma, becomes thickened, corrugated and white with keratin (Figs 16.8A and B).

#### *Decubital Ulceration*

Ulceration of the prolapsed tissue is often said to be caused by friction with the thighs and clothing. Although this may be partly true, it is notable that the ulcer is nearly



Figs 16.7A and B: (A) Gross prolapse of the vaginal wall and, without further investigation, it is impossible to say whether it is a cystocele or rectocele. (B) Insertion of a speculum to hold back the anterior vaginal wall shows that the lesion is a rectocele

always *on the most dependent part* of the cervix or vagina, and not at the sides where friction is greatest (Figs 16.8 and 16.9). It is to be regarded, therefore, more as the result of circulatory and nutritional changes than of trauma, and as being aetiologically similar to a varicose ulcer of the leg.

### Hypertrophy of the Cervix

#### *Elongation of the Supravaginal Cervix (Fig. 16.2B)*

If the lower cervix and vaginal vault descend while the upper cervix remains well supported, the supravaginal cervix becomes elongated. In this way the total length of the uterus can become considerably increased and a cavity measurement of 12 or 15 cm is by no means uncommon. This change does not occur in total prolapse where all the supports of the uterus fail.

#### *Congestion and Oedema (Fig. 16.5)*

The downward displacement of the uterus puts tension on the descending vascular connections of the cervix, interfering with the venous and lymphatic drainage.

#### *Glandular Hypertrophy ('adenomatous change')*

The state of chronic congestion sometimes leads to actual hypertrophy or hyperplasia of the glandular and connective tissue elements in the cervix.



**Fig. 16.8:** Uterovaginal prolapse with healing decubital ulcers. The vaginal epithelium is keratinized as a result of exposure. The cervix is hidden behind the prolapsed vaginal walls

### Obstructive Lesions of the Urinary Tract

A large cystocele, with angulation of the urethra during straining, causes difficulty in emptying the bladder; this results in hypertrophy of the bladder walls and trabeculation (Fig. 16.10). The downward movement also involves the lower ends of the ureters, so they become attenuated and constricted in the ureteric canals at the sides of the uterus. The drag is manifested by an exaggeration of the interureteric bar (Fig. 16.10). Back pressure from the bladder and obstruction of the lower ureter lead ultimately to *hydroureter* and *hydronephrosis* (Fig. 16.11).

### Infection of The Urinary Tract: Renal Failure

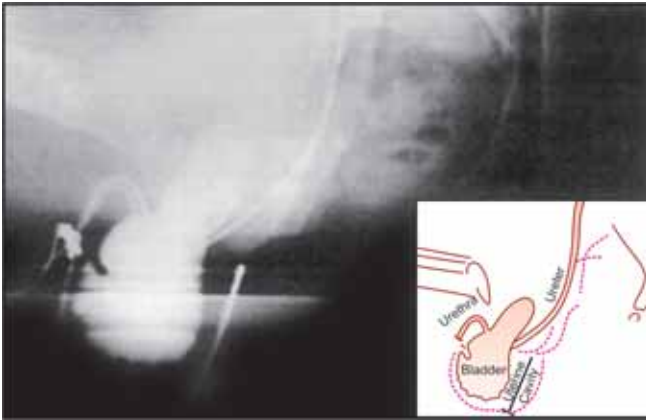
If the pouch of a cystocele is low it may not be emptied during micturition. In such circumstances and if the cystocele is chronically unreduced, a calculus can form in the pouch. The residual urine favours the growth of organisms so *cystitis* complicates cystocele sooner or later. There may also be *pyelitis* and *pyelonephritis*, especially if the upper urinary tract is dilated. The final outcome may be renal failure.

### Incarceration of the Prolapse

The extruded cervix and adjacent vaginal walls sometimes become so congested and oedematous that



**Fig. 16.9:** Uterovaginal prolapse with decubital ulceration of the cervix. Without further investigation it is impossible to say whether this represents prolapse or complete procidentia



**Fig. 16.10:** Lateral urethrocytography to show the effect of gross uterovaginal prolapse with cystocele on the urethra, bladder and ureters. The uterine cavity is marked by a metal stem. Inset: Explanatory tracing of the radiograph. The created outline of the bladder indicates hypertrophy of the detrusor muscle. The ridge, marked by an arrow on the inset, is the hypertrophied interureteric bar. The bladder hypertrophy is the result of efforts to empty the cystocele during voiding and because of difficulty caused by angulation of the urethra. The lower ends of the ureters are dragged down to the level of the ischial tuberosities. (By permission of Mr Henry Roberts and of the Editor, *J Obstet Gynaecol Br Emp*)

the patient finds the prolapse irreducible. For the medical attendant the problem is not difficult; all that is necessary is to grip the whole mass and squeeze it back in reverse order, that is, the lower vaginal wall first and the cervix last. Only once have I seen a prolapse which could not be reduced. If true incarceration does occur, it is first treated by keeping the patient lying flat with the foot of the bed raised for 1-3 days, and applying ice packs to the congested tissues.

### Carcinoma of the Cervix or Vagina

It is a remarkable fact that, irrespective of chronic irritation and ulceration, cancer of the cervix or vagina is rarely seen in untreated cases of prolapse. When it is, the symptoms of prolapse often disappear as the tissues become fixed.

### Genital Prolapse and Pregnancy

If the woman suffering from genital prolapse conceives, no special problems usually arise. In the first trimester, increased uterine weight associated with relaxation and congestion of pelvic tissues tends to accentuate the



**Fig. 16.11:** Dilated and displaced ureters associated with utero-vaginal prolapse, demonstrated by intravenous pyelography

prolapse. Later, however, when the uterus and its contents rest on the pelvic brim, the prolapse is often less troublesome. Nevertheless the uterus sometimes remains low in late pregnancy and delivery at term through a cervix lying outside the vulva is described.

### Aetiology

The occurrence of prolapse implies failure of one or more of the supports of the uterus and vagina which are described in Chapter 2.

In 95 per cent of cases of prolapse, the patient is multiparous and the implication is that childbearing is an important causal factor. Nevertheless, it should be recognised that the majority (probably not less than 80%) of middle-aged women are parous, and that those who do develop prolapse might have done so even if they had remained childless. The part played by childbirth should not, therefore, be overestimated.

### Predisposing Factors

#### *Congenital or Developmental Weakness of the Supports*

This is the most important of all factors and it operates in multiparous as well as nulliparous prolapse. It may explain *why prolapse often follows easy rather than difficult*

*labour*, the inherent weakness of the fibromuscular tissues allowing rapid dilatation of the birth canal as well as subsequent prolapse. Sometimes, during the examination of a young nulliparous woman, it will be noted that the vaginal wall is atonic and that the uterine supports are weak; it is then possible to foretell that, if she ever has a baby, she will inevitably develop prolapse. Syndromes such as the Ehlers-Danlos syndrome are characterized by fascial and connective tissue weaknesses. These women have a high incidence of urinary incontinence and most authors believe that the incidence of pelvic organ prolapse is also increased in this group. Congenital weakness of pelvic floor ligaments and fascia may also be found with spina bifida or bladder extrophy.

Other developmental features which favour prolapse are: shortness of the vagina; deep uterovesical and uterorectal peritoneal pouches; and, possibly, uterine retroversion, but this is not as important as was formerly believed.

The part played by an inherent defect in the supporting tissues is also evidenced by the fact that prolapse, both nulliparous and multiparous, has a *strong familial incidence* (Figs 16.12A and B).

True *congenital prolapse* is rare but cases are described in which the uterus is displaced outside the vulva at birth. When the baby is otherwise normal, this happening may be related to prolonged pressure of the birth canal

on the foetal abdomen during breech delivery. In such a case, immediate replacement of the uterus is said to be followed by 'permanent' cure; it is difficult to believe that the prolapse does not recur in adult life.

#### *Injury Sustained During Childbirth*

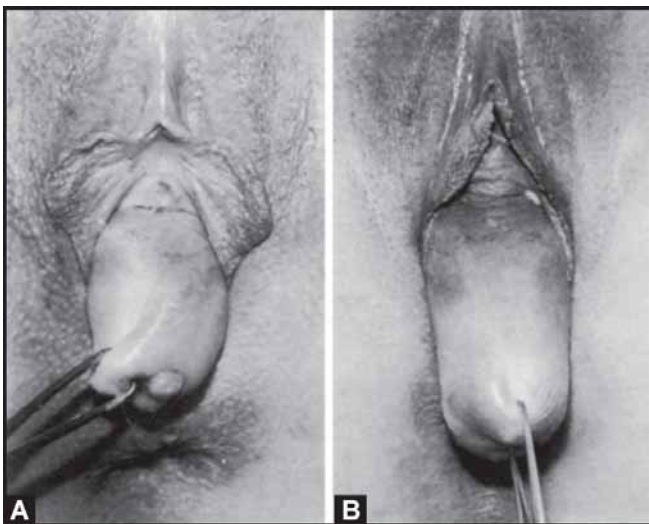
The delivery of a child inevitably disturbs, stretches and sometimes tears the supports of the pelvic viscera; if these are already weak, they subsequently fail. The exact injury and the mechanism whereby it is sustained is unknown. One possibility is premature bearing down or fundal pressure before full dilatation of the cervix. Traction on the presenting part before the cervix is fully dilated could damage the cardinal ligaments, so care is necessary in using the vacuum extractor during the first stage of labour. Denervation changes have been documented in the pelvic floor and anal sphincter following vaginal delivery. These are thought to lead to temporary, and sometimes permanent, urinary and faecal incontinence. Use of positions other than squatting for delivery may increase the incidence of prolapse.

Perineal and vaginal tears, even if they become infected, do *not* cause prolapse although they are alleged to do so. Indeed, it will often be noted that a scarred area of the vagina is the only part which does *not* prolapse, and that the uterus sometimes depends for its support on a deep laceration in the cervix and vaginal vault. Moreover, it is a well-accepted clinical observation that it is very uncommon to see descent of either the uterus or the vaginal walls in cases of unhealed complete perineal tear. Good puerperal rehabilitation by proper exercises is important in preventing prolapse.

To summarize, the evidence so far available suggests that overstretching or prolonged distension of the vagina with disruption of its fascial envelope is more conducive to *vaginal* prolapse than is obvious tearing, and that a perineal laceration or episiotomy which allows a quicker second stage may be protective although there are some who doubt this. As regards uterine prolapse, little can be said except that it is rarely seen in women who have only been delivered by caesarean section!

#### *Surgical Injury*

Contrary to what is often stated, hysterectomy is not a cause of subsequent vaginal or vault prolapse. This operation does, however, sometimes reveal a pre-existing weakness. Thus, a very large or well-supported uterus



**Figs 16.12A and B:** Nulliparous uterovaginal prolapse occurring in sisters, (A) Virgin aged 50 years, (B) Virgin aged 45 years. A third sister had had one child and was operated on for prolapse 5 years previously

may hold up a vagina whose own supports are weak and this defect may become apparent when hysterectomy is carried out.

Vault prolapse is as likely to occur after subtotal than after total hysterectomy, despite the fact that the latter involves division of more elements of the transverse cervical ligaments. But it does leave more fibrosis and the scar tissue might have a supporting role. If the cervix is not removed it may act like the apex of an intussusception and encourage the vault to evert.

Vaginal hysterectomy is alleged to be more commonly followed by vault prolapse than is abdominal hysterectomy. But this is because many gynaecologists only adopt the vaginal approach when there is some degree of prolapse already present. If they fail to strengthen the vaginal supports and to excise any enterocele while removing the uterus, subsequent vault prolapse is almost inevitable. Other things being equal, vaginal hysterectomy is no more likely to be followed by vaginal prolapse than is abdominal hysterectomy; it should be less likely because it offers the surgeon an opportunity to correct any weakness already present.

Vaginal or uterovaginal prolapse is sometimes seen following abdominoperineal excision of the rectum and is said to be a late complication of 4 per cent of such operations.

#### *Atrophy of Supporting Tissues at the Climacteric*

Congenital or developmental weakness of the pelvic supports, and obstetrical injuries to them, often do not become manifest until after the menopause. Until that time, the supports remain adequate but the atrophy which follows cessation of ovarian function is the 'final straw' and is followed by prolapse within a few years. Prolapse sometimes suddenly appears 3 or 4 weeks after delivery, whereupon the woman rests for a few days and then often has no more trouble until the menopause. Nulliparous prolapse is mostly seen at or after the menopause but I have known it to occur in unmarried girls in their late teens.

#### **Activating Factors**

If a weakness is present, the circumstances likely to precipitate the onset of prolapse are as follows:

- Increased intra-abdominal pressure caused by a chronic cough, chronic constipation, ascites, tumour formation, lifting heavy weights, doing extra work

(for example, nursing a sick friend or relative) and straining at stool.

- Increased weight of the uterus resulting from subinvolution, myohyperplasia or a *small* tumour. A uterine tumour which is so large that it rests on the pelvic brim prevents prolapse.
- Traction on the uterus by vaginal prolapse or by a large cervical polyp. In other words, descent of the vagina can precede and possibly cause uterine prolapse. The rough surgeon can precipitate prolapse by pulling strongly on the cervix during an operation.

#### **Symptoms**

The amount of discomfort and inconvenience experienced by the patient is extremely variable. Some women suffer complete procidentia for many years without being seriously incapacitated, and without having to restrict their activities. On the other hand, other women complain bitterly when they suffer only a moderate degree of uterine or vaginal descent; the difference may in part be explained on the basis of resistance offered by the supporting ligaments. Little resistance, as in gross uterovaginal prolapse, means little discomfort. As a rule, only a few of the following possible symptoms are seen in any one case. The characteristic of nearly all symptoms is that they *are immediately and completely relieved by lying down*.

#### **A Sensation of Swelling or Fullness in the Vagina**

This, or a complaint of 'something coming down outside' is common. The swelling or 'something' may be the cervix, cystocele, rectocele or all three.

#### **A Dragging Discomfort in the Lower Abdomen and Pelvis**

This sort of symptom is also described as a 'bearing down sensation' because the swelling in the vagina gives the woman a desire to evacuate it.

#### **Urinary Symptoms**

These depend on descent of the anterior vaginal wall and on displacement of the bladder and urethra.

#### *Frequency*

This at first is only diurnal and is due to mechanical irritation of the trigone on incomplete voiding. When

the frequency becomes nocturnal as well as diurnal and is accompanied by scalding, it means that the situation is complicated by cystitis. Urgency may also occur but it is important to exclude other causes such as detrusor instability.

### *Difficulty in Emptying the Bladder*

The patient finds it difficult to empty the pool of urine in a large cystocele and the more she strains the greater the difficulty. Thus when she relaxes at what she believes is the completion of the act, she has a desire to pass urine again immediately. In severe uterovaginal prolapse the urethra may become so acutely angled that retention results (Fig. 16.10). The intelligent woman gets over these difficulties by digitally holding up the prolapse during micturition.

### *Stress Incontinence*

Although traditionally regarded as a symptom of prolapse, stress incontinence of urine occurs as frequently in women without, as in those with, genital prolapse. In both groups the incidence is 40 per cent. Urethral incompetence is not related to the type or severity of the displacement of the uterus and anterior vaginal wall, nor to the position of the bladder and urethra in the pelvis. The cure of stress incontinence is not dependent on the anatomical success of an operation for prolapse. For these and other reasons, urethral incompetence is best dissociated from prolapse.

### Difficulty in Emptying the Rectum

This is a common symptom of rectocele, although many women are too embarrassed to mention it spontaneously. Faeces collect in the forward bulge of the bowel and cannot be evacuated unless the rectocele is held back digitally. Symptoms are sometimes disproportionate to the degree of defect.

### Backache

This is in the midline at the lumbosacral or sacral level and is diffuse, deep seated and unaccompanied by local tenderness. *It is completely and immediately relieved by rest and is never experienced in bed or on rising in the morning;* it comes on gradually during the day. Contrary to what was formerly believed, prolapse is a rare cause of backache; when this symptom is cured by an operation

for prolapse it is most often because the operation provides the patient with a period of enforced rest. Vaginal prolapse certainly does not cause backache; if uterine prolapse does, it is because of traction on the uterosacral and cardinal ligaments.

### *Discharge*

A purulent and sometimes bloodstained vaginal discharge is a manifestation of decubital ulceration. Leucorrhoea can be caused by increased activity of the cervical glands associated with congestion.

### Physical Signs

The presence, type and extent of prolapse and presence of stress incontinence, if any, can usually be determined by asking the patient to bear down or to cough during examination. Minor degrees of uterine prolapse may only be recognized *by feeling* descent of the cervix while the patient is straining. Rectal examination is useful to demonstrate rectocele and to distinguish it from enterocele.

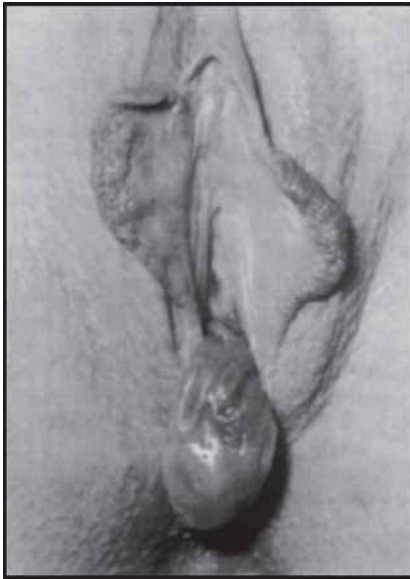
Sometimes fairly severe degrees of prolapse are not evident at the time of examination because: the woman is not straining hard for fear of causing an escape of flatus or faeces; she may have been resting immediately prior to examination; if she has been wearing a pessary for a long time it may be several days or weeks before the prolapse becomes obvious again.

If there is doubt the patient should be asked to stand or walk for some time before examination. Occasionally it is necessary to test for uterine descent by pulling on the cervix with a volsellum.

### Differential Diagnosis

From the standpoint of symptoms and signs, prolapse has to be distinguished from the following.

- A vulvar tumour or any polypoid tumour which projects through the vulva on straining. A cervical polyp (Fig. 16.13) and a urethral caruncle are the most frequent causes of confusion. Metastases from uterine tumours, e.g. adenocarcinoma or choriocarcinoma may be seen.
- Hypertrophy and elongation of the cervix.
- Vaginal or periurethral cysts. These may be congenital, e.g. Gärtner's cyst or inclusion dermoid cysts following trauma or surgery. They simulate cystocele or rectocele but are different in that they

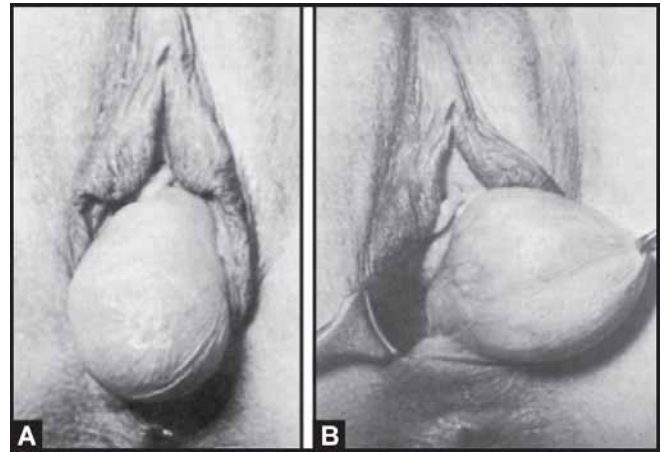


**Fig. 16.13:** A cervical polyp simulating prolapse. The woman in this case, aged 55 years, had had a repair operation for prolapse several years previously. Her complaint was a 'recurrence of the prolapse'. The tumour, however, proved to be a cystic adenoma arising from the cervical stump (cervix previously amputated) of a well-supported uterus

cannot be reduced (Figs 16.14A and B). If there is doubt, a rectal examination or the passage of a sound into the bladder indicates the anatomy of the swelling.

- A diverticulum or prolapse of the urethra. This can be mistaken for urethrocele or cystocele.
- Inversion of the uterus
- Inversion of the bladder
- Varicose veins of the vulva or vagina, haemorrhoids and rectal prolapse
- Congestion of the vagina associated with vaginitis which gives a sensation of fullness and is often mistaken by the patient for prolapse
- All other causes of low backache
- All other causes of bladder symptoms.

Although prolapse can usually be recognised easily, it may be difficult to say whether it is responsible for the patient's particular symptoms, especially if the prolapse is not severe and the complaint is an ache or a pain. If there is doubt a *pessary test* should be applied. Only if the discomfort is relieved by a ring, and if it returns when the ring is removed, can it be credited to the prolapse with reasonable certainty.



**Figs 16.14A and B:** A vaginal cyst simulating prolapse, (A) The tumour presenting at the vulva, (B) Lateral displacement shows that the tumour is a cyst arising from the side wall of the vagina and therefore probably wolffian duct in origin

## Prevention

### *During Labour and the Puerperium*

- Avoid attempts at delivery, by the patient as well as by the attendant, before the cervix is fully dilated.
- Avoid an unnecessarily long second stage by episiotomy and, if need be, by low forceps or vacuum extraction.
- Repair all tears and incisions accurately in layers.
- If possible, use delayed absorbable sutures for the repair of the muscle layer.
- Do not express the uterus when attempting to deliver the placenta.
- Encourage pelvic floor and other postnatal exercises. These favour involution of all the pelvic tissues. Early ambulation is more likely to prevent than to cause prolapse.
- Treat puerperal constipation in order to avoid strong bearing down efforts while supporting ligaments are slack.
- The correction of puerperal retroversion, once advocated strongly, is of no value.

### *At Hysterectomy*

Many suggest that the chance of subsequent vaginal prolapse can be reduced if, during abdominal hysterectomy, the stumps of the uterosacral and cardinal

ligaments are stitched to the vaginal vault. *A deep cul-de-sac should be obliterated by Moschowitz sutures. Sacropexy can be done in high-risk situations, e.g. collagen disorders.*

During vaginal hysterectomy, excision of redundant peritoneum, tightening of the cardinal and uterosacral ligaments and their inclusion in the vaginal vault are important prophylactic steps.

The increasing acceptability of oestrogen replacement therapy in postmenopausal women may decrease the incidence and severity of prolapse.

### Treatment

#### Physiotherapy

When there is only a minor degree of prolapse, and especially during the 6 months following delivery, Kegel's pelvic floor exercises carried out regularly are of some value. Their effect is limited, however, because they only influence the voluntary muscles, i.e. the bulbocavernosus, superficial and deep transverse perineal and levator ani muscles and not the main fascial supporting tissues.

Vaginal cones of increasing weight have been tried by some with limited success.

#### Pessary Treatment

Palliative treatment consists of preventing the descent of the uterus and vaginal wall by means of a supporting pessary of which there are many types. Those most commonly employed are 'rings'.

The insertion of a pessary may be indicated in the following circumstances.

- During pregnancy
- Immediately after pregnancy and during lactation
- When further childbearing is intended *in the near future*. This is a debatable indication.
- Medical disorders which make operation unsafe
- Refusal of operation on the part of the patient
- As a therapeutic test to determine if symptoms are due to prolapse
- To promote the healing of a decubital ulcer prior to operation.

A pessary does not cure prolapse; it merely holds up the tissues. Sometimes, however, if a slight prolapse is controlled for some months the supports recover tone and the patient may then be able to manage without the pessary for some time. This is particularly true in the

puerperium. However, without concomitant exercises the symptoms gradually worsen and the size of pessary required may increase with time.

### Operative Treatment

#### Indications

Some sort of surgical procedure is nearly always the best treatment for established prolapse but *is only necessary if the condition is causing symptoms or is interfering with the woman's normal activities*. If the prolapse is an incidental finding, and if it is not certain that a patient's symptoms are attributable to it, operation is best deferred. Nothing is lost by waiting and, even if the condition becomes worse in the meantime, the subsequent operation is not technically more difficult; indeed it may be easier.

Youth and the intention to have more children in the future are not contraindications to operation, although they may modify surgical technique (*see below*). Even if the prolapse recurs after further pregnancies, and this is not inevitable if the management is good, the original operation is not to be regarded as a waste of time. It is unreasonable to advise the young and potentially active mother and wife to persevere with makeshift measures until she is too old and inactive to enjoy the comfort which surgery can give.

Equally, old age and ill health are not necessarily contraindications, for the operation involves little risk if care is taken over anaesthesia. It is easily performed under regional anaesthesia in old women.

#### Preoperative Management

In assessing and correcting the general health of the patient before operation, particular attention should be paid to the urinary system. Urinalysis and blood urea estimations are essential in all cases, pyelography and renal function tests in some. Urinary tract infection should be eliminated lest it show an exacerbation postoperatively.

If the vaginal walls are senile and atrophic, oestrogens may be administered in the form of conjugated equine oestrogens, 0.625 mg daily, 3-4 weeks before operation. Alternatively, daily application of oestrogen cream in the vagina may provide the same benefit. The object is to improve the healing power of the tissues.

Although some say it is unnecessary, decubital ulceration should be treated before operation. The ulcer



is always secondarily infected and its very presence means that the tissues have a low healing capacity. To cure it, admit the patient to hospital and keep her lying flat in bed as much as possible. The prolapsed organs are replaced and are packed in position by a tampon of gauze which is changed every day. Impregnation of the tampon with an antiseptic is unnecessary because its action is only to restore the circulation by keeping the organs in normal position. By this method fairly large ulcers heal in 7-14 days.

The above treatment, while giving excellent results, means prolonged hospitalization and the physical immobility of the patient may encourage thromboembolism. To avoid these the prolapse can be temporarily controlled, in many cases, by means of a ring pessary. Provided this is made of non-irritant plastic material and does not press directly on the ulcer, it restores the circulation of the tissues so well that healing of a decubital ulcer can be expected in 2-3 weeks.

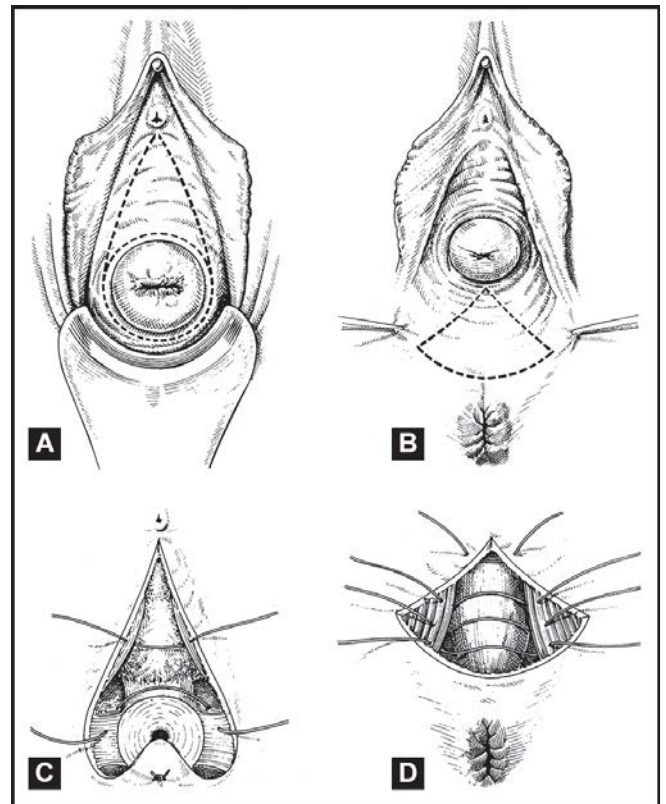
### Types of Operation

The aim of surgery is to restore the normal anatomy. A normal vaginal length should be maintained with its axis directed towards S3-S4. Hysterectomy is not essential but it facilitates the repair of an enterocele. In the post-menopausal woman it allows the removal of an organ which may harbour unsuspected disease or be a focus for such a problem in the future. Most importantly, the strength of various supporting structures should be assessed and surgery planned accordingly, supplementing ligamentous and fascial repair with synthetic materials attached to alternate supports, e.g. the sacrospinous ligament, sacrum, etc. if required. In the repair of vaginal prolapse, it is important to identify whether the deficiency is in the central or lateral compartments and whether the split of the fibres is transverse or longitudinal, so that accurate repair is done for optimal results.

#### Anterior Colporrhaphy

This is designed to cure cystocele and urethrocele. The vaginal wall is dissected free from the fascia, bladder and urethra and its redundant part excised. The excised portion is usually elliptical or triangular with its base at the cervix and its apex near the urethral orifice (Fig. 16.15). If there is a transverse ridge about 1 cm above the urethral orifice it is best not disturbed because it marks

an intact triangular ligament and compressor urethrae. The bladder is well separated from the uterus and displaced upwards; the pubovesicocervical fascia and the pubo-urethral ligaments are then stitched together in the midline to support the bladder and the vaginal wall is closed. It is important to avoid over-correction of the posterior cystocele to prevent a run-off type of urinary incontinence. The surgical management of stress incontinence is often done at the same time. It is also important to use delayed-absorbable sutures in all cases. In fact, some go so far as to advise the use of a first layer



**Fig. 16.15:** The principles of the Manchester operation for uterovaginal prolapse, (A) Incisions for anterior colporrhaphy and for amputation of the cervix, (B) Incisions for posterior colporrhaphy, a procedure included in the classical operation but unnecessary unless a rectocele is present, (C) Suturing of the bases of the cardinal ligaments in front of the cervix before completing the covering of the cervical stump with vaginal epithelium. Suturing the pubocervical fascia before closing the vaginal wall from above downwards, (D) Sutures placed in the edges of the levatores ani before closure of the vaginal wall and perineum. Not shown here, but essential in every repair of this kind, is the opening of the pouch of Douglas behind the cervix immediately after the amputation. All redundant peritoneum is then excised and a culdoplasty done

of non-absorbable sutures for fascial support, covered over with a second row of delayed-absorbable sutures. Paravaginal defects can be repaired through an abdominal retropubic approach, through a vaginal retropubic incision or laparoscopically, all of which aim to reattach the pubocervical fascia to the arcus tendinus and to the fascia overlying the obturator internus muscle.

*Steps of Anterior Colporrhaphy*

*Principles*

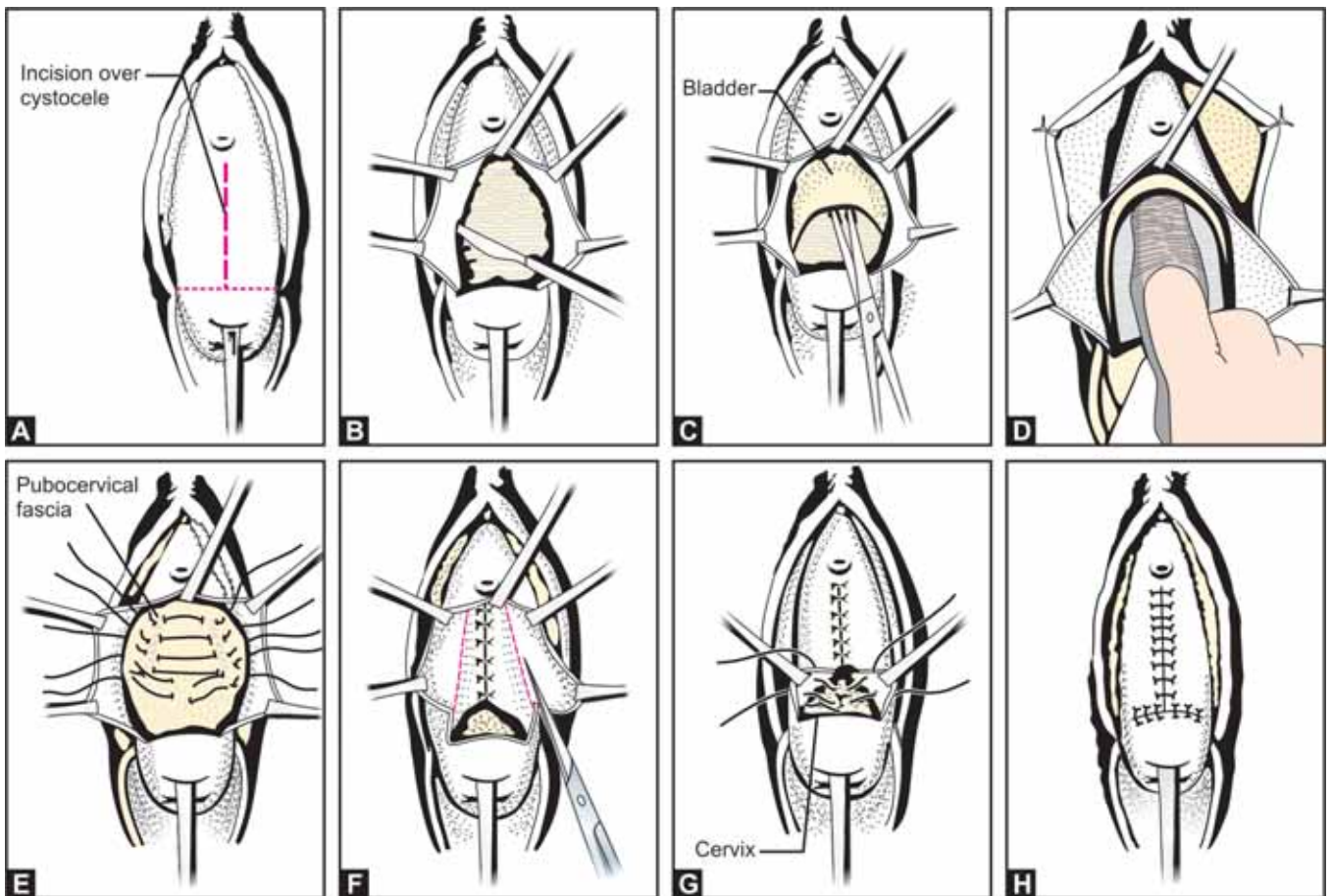
- To excise a portion of the relaxed anterior vaginal wall
- To mobilise the bladder and push it upwards after cutting the vesico cervical ligament
- Bladder is permanently supported by tightening the pubocervical fascia

*Operative steps (Figs 16.16A to H)*

- Triangular vaginal flaps including the fascia separated from endopelvic fascia
- Line of cleavage vesico vaginal space
- Vesico cervical ligament is divided
- Bladder is pushed upwards
- Pubo cervical fascia is plicated with interrupted O catgut sutures
- Thus closing the hiatus through which bladder herniates
- Redundant portion of the vaginal mucosa is cut on the either sides
- Cut margins of the vagina apposed.

*Enterocoele Repair*

At vaginal hysterectomy, an enterocele sac should always be looked for and excised after dissection from



Figs 16.16A to H: Steps of anterior colporrhaphy

above downwards. A high ligature of the peritoneum can be done by a purse-string ligature which incorporates the round and the uterosacral ligaments as well. The third important step is colporrhaphy to shorten the cardinal-uterosacral complex support of the vaginal cuff. When the uterosacral ligaments are long and strong a McCall-type of culdoplasty is indicated. If, on the other hand, the strength of the cardinal-uterosacral ligaments is doubtful, it is safer to anchor the vaginal vault to the sacrospinous ligament as a primary procedure.

The enterocele can be corrected abdominally by obliterating the pouch of Douglas by the Moschowitz or Halban technique.

#### *Posterior Colpoperineorrhaphy*

This is a similar type of operation for rectocele and a defective perineum. Ordinarily, a roughly triangular portion of the posterior vaginal wall is excised, the base of the triangle being at the introitus and the apex just above the level of the rectocele. In case of a high rectocele, dissection right up to the cervix and excision of redundant peritoneum of the pouch of Douglas are necessary. The underlying rectovaginal fascia is sutured and the edges of the levatores ani are brought together in the midline. The vaginal wall is then sutured and finally the superficial perineal muscles and skin. The operation has the effect of lengthening the perineum and tightening the introitus. The goal is a normal vaginal axis and a depth of about 10 cm, which can take the vault above the levator plate and prevent later development of enterocele. Endorectal or transrectal repair and placement of a mesh between the vagina and rectum to support the rectovaginal fascia may be indicated in some cases.

Postmenopausal women who have undergone repair operations should be advised to continue local oestrogen applications lifelong. If there are no contraindications, they can also be advised standard HRT regimens.

The traditional routine performance of posterior colpoperineorrhaphy as a part of all operations for genital prolapse has a historical rather than a sound anatomical basis. Repair of the posterior vaginal wall and perineum is not necessary in at least 50 per cent of operations for prolapse, and then only for the cure of undoubted rectocele (which is the least common form of prolapse).

The advantages of avoiding perineorrhaphy in association with other procedures for repair of cystocele

and uterine prolapse are that the patient hardly ever has postoperative retention and cystitis, is relatively free from postoperative local discomfort and is unlikely to suffer anatomical dyspareunia subsequently. Here it must be emphasized, however, that adequate preoperative examination is essential, otherwise a weakness in the posterior wall left uncorrected may set the stage for recurrence of prolapse.

*Fothergill or Manchester operation:* This operation, variously credited to Donald and to Fothergill, both of Manchester, combines anterior colporrhaphy, amputation of the cervix and posterior colpoperineorrhaphy in one procedure. Fothergill did not always carry out a posterior repair, whereas Donald did. It is appropriate in young women with any degree of uterovaginal prolapse. It is avoided in women anxious for more children because amputation of the cervix is associated with a high incidence of infertility, premature delivery and cervical dystocia.

Dilatation and curettage is performed as the first step of the operation to facilitate creation of the vaginal flaps and to rule out malignancy. The most essential feature of the operation is the suturing of the cut cardinal ligaments and other paracervical tissues in front of the stump of the cervix. This has the effect of tightening the cardinal ligaments and of maintaining anteversion by pulling the cervix upwards and backwards; it also lengthens the anterior vaginal wall- an important technical point.

If an enterocele is present, it is corrected.

*Extended Manchester operation:* Improper attention to an enterocele or a deep *cul-de-sac* may lead to a recurrence of the problem. In the extended Manchester operation, the *cul-de-sac* is opened, the peritoneum excised and the uterosacral ligaments plicated together. Shirodkar dissected the uterosacral ligaments and sutured them in front of the cervix, as he believed that these ligaments were more important supports of the uterus than the cardinal ligaments. Further, in his operation, amputation of the cervix was avoided, thus offering a better alternative for women who desired further childbearing.

#### *Vaginal Hysterectomy with Anterior Colporrhaphy and Posterior Colpoperineorrhaphy*

Vaginal hysterectomy with posterior culdoplasty and colporrhaphy is preferred in premenopausal patients when prolapse is complicated by uterine haemorrhage

or disease; or when some condition such as diabetes or obesity indicates a higher than average risk of the subsequent development of uterine cancer; or when the patient is over 70 years of age. In postmenopausal patients, removal of the uterus facilitates hormone replacement therapy in that there is no withdrawal bleeding and no need for progesterone or for monitoring of endometrial changes. In this latter group, both tubes and ovaries may be removed vaginally at the same time.

Vaginal hysterectomy by itself does not cure prolapse. For this purpose it remains essential, after the uterus is removed, to excise any redundant peritoneum, to strengthen the vaginal vault by approximating the uterosacral and broad ligament pedicles and to tighten the pubocervical fascia. If proper attention is paid to these matters, it is not necessary to add posterior colpoperineorrhaphy unless a rectocele is present.

## Other Operations

### *Abdominal Sling Operations*

**Abdominocervicopexy-** (Purandare's Cervicopexy) Designed for young women with II or III degree prolapse and who are desirous of retaining their child bearing and menstrual functions. Rectus sheath used as a sling and are anchored to isthmus of the uterus anteriorly with non absorbable sutures.

### *Shirodkars abdominal sling*

Technically difficult. Merseiline tape is passed through the substance of isthmus posteriorly at the level of attachment of uterosacral ligament with nonabsorbable sutures other end is attached to the anterior sacral ligaments and periosteum in front of sacral promontory.

### *Khanna's sling*

Merselene tapes is fixed to the isthmus and the two free ends brought out retro-peritoneally to emerge out at the lateral margins of rectus abdominus and then anchored laterally to the anterior iliac spine on either side.

*Ventrofixation* is of no value for uterine prolapse unless it is combined with some form of vaginal plastic procedure. A modified *Gillianis operation* is sometimes combined with a limited vaginal repair, or with tightening of the uterosacral ligaments, in the treatment of uterine prolapse in young women, especially when they wish to preserve uterine function, fertility and a functional vagina.

Other *sling operations* have been described in young women with congenital prolapse which include abdominal operations a modified Gilliam's operation using a strip of fascia from the anterior rectus sheath; fixation to the anterior superior iliac spine with mersilene tape; sacrospinous fixation. Transvaginal sacrospinous uterine fixation has also been described and this may carry the advantage of a decreased potential for adhesion formation.

*Abdominal hysterectomy* is sometimes needed when prolapse surgery needs to be combined with the removal of pelvic tumours or when suprapubic colpourethropy for severe genuine stress incontinence is planned. Redundant anterior and posterior vaginal walls can be excised and the deep *cul-de-sac* obliterated by the Moschowitz technique.

Partial obliteration of the vaginal lumen by creating a septum between the anterior and posterior vaginal walls (*Le Fort's operation*) is sometimes advocated for severe prolapse in old women, and for vaginal eversion after hysterectomy. The Manchester operation, however, is just as safe and the results are better, especially if the surgeon is prepared to sacrifice coital function by making a 'pencil vagina'. Moreover, the drag of the septum, created in Le Fort's operation is liable to open the internal urethral sphincter to cause stress incontinence. The Le Fort's operation can be done under local anaesthesia and this may be of value in some old women with severe medical problems.

### *Operations for Vaginal Prolapse after Hysterectomy*

Eversion of the vagina following hysterectomy in an older and more sedentary patient is best treated by a transvaginal vault suspension with anterior colporrhaphy and posterior colpoperineorrhaphy. This method is also suitable for women with a previous abdominal hernia repair with a mesh *in situ* or with a history of intestinal obstruction or adhesive disease. Sacrospinous ligament fixation is a suitable method in these patients. Injury to the pudendal vessels and nerves can occur. It is important to identify and correct an enterocele and narrow the vagina, if necessary.

Abdominal sacral colpexy provides the surest and strongest correction for vaginal vault prolapse and is preferred in younger patients with more strenuous physical activity or those with associated diseases that increase intra-abdominal pressure chronically, e.g.

asthma, chronic obstructive pulmonary disease, chronic constipation, etc. It is also the preferred operation in patients with previous failed repairs and a shortened, scarred vagina. Mersilene or teflon mesh is used to attach the vault to the anterior longitudinal ligament of the first sacral vertebra. The mesh is peritonealized to avoid bowel entrapment. The venous plexus in front of, and the pelvic nerves lateral to, this ligament can be injured. A culdoplasty by the Halban or Moschowitz technique is done as an essential part of the procedure. The vaginal vault can also be attached to the anterior abdominal wall by mersilene mesh. Strips of fascia from the anterior rectus sheath have been used but these have poorer long-term results and occasionally the patient develops a hernia. Stress incontinence may occur or be aggravated in 10-25 per cent of cases if there is excessive tension on the anterior vaginal vault, for which reason some would also recommend performing a Burch colpourethropy routinely.

Laparoscopic sacrocolpopexy has been undertaken but long-term results are awaited.

### Results of Operations

The results of operations for prolapse depend very much on the skill of the surgeon, and on selection of operation according to the case and the surgeon's own experience. In general, the anatomical results are good, being permanently satisfactory in at least 90 per cent of cases. Symptomatic results are also good except in respect of the following.

#### *Stress Incontinence*

If the woman treated for prolapse happens also to suffer from urinary stress incontinence, this symptom is not always cured by anterior colporrhaphy alone even though the anatomical result of anterior colporrhaphy is satisfactory. Moreover, anterior colporrhaphy, by interfering with the internal urethral sphincter, *causes* stress incontinence in 2-3 per cent of women who do not have this complaint previously. It is essential to have adequate and appropriate preoperative assessment of all women with urinary symptoms and prolapse and perform additional procedures accordingly.

#### *Dyspareunia*

It is not always realized how often women suffer dyspareunia and apareunia after surgical treatment for prolapse. Twenty-five per cent of women coming to

operation for prolapse have already discontinued coitus. This is usually because of waning libido in husband or wife. Another 25 per cent, however, find that the cure of prolapse brings an end to marital relations. The reasons for this are as follows.

- Fear that coitus will impair the result of the operation.
- An early attempt at coitus, before tenderness has subsided and without the realization that the introitus is narrower, causes pain. This, together with fear of injury, causes *vaginismus*.
- Often the operation is done at an age when senile atrophy is to be expected. Coitus is discontinued for several months and, when it is attempted again, contracture has taken place. Resignation then takes the place of persistence, especially as the sex urge is weakening in both husband and wife.
- Narrowing and shortening of the vagina and introitus is the most important cause. Errors in surgical judgement arise because no allowance is made for involution of overstretched tissues, for muscular relaxation induced by general anaesthesia (and particularly by relaxant drugs), and for senile atrophy. Much of the trouble arises over unnecessary perineorrhaphy. The introitus should be about two fingers loose at the end of surgery.

Posterior colpoperineorrhaphy is to be avoided unless it is clearly indicated, *the assessment being made before the woman is anaesthetized*. It is also important preoperatively to ask every woman, no matter how old she may be, whether she still practises coitus. If she does, a careful operative technique should be followed by explanation and guidance about the subsequent resumption of the practice.

Postoperative HRT is of benefit in improving the results of operation by improving the tone of the tissues and also reducing symptoms of atrophy such as dyspareunia.

### Failed Operations

The following are the reasons for failure to cure prolapse.

- An ill-chosen operation
- Poor surgical technique, especially in the region around the cervix
- Omission to recognize and treat an enterocele.
- Shortening of the anterior vaginal wall
- Developmental and inherent weakness of the supports. This explains why prolapse is more difficult to cure in nulliparae than in multiparae.
- Another pregnancy after the operation.

## Pregnancy after Repair Operations

The effects of operations for prolapse on subsequent pregnancies vary with the technique employed. Some are related to amputation of the cervix, some to colporrhaphy.

### *Amputation of the Cervix*

The higher the level of amputation, the more likely is childbearing to be affected. The possible effects are:

- No effect
- Infertility. Many women avoid conception after operation but 75-90 per cent of women with opportunity to conceive fail to do so after cervical amputation. This may be due to a loss of cervical mucus and distortion of the cervical canal.
- Abortion and premature labour. The incidence of these complications is decidedly increased. They occur in 20-50 per cent of subsequent pregnancies and are due to cervical incompetence.
- Precipitate labour. This occurs because of the absence of cervical resistance.
- Cervical dystocia. Excessive fibrosis interferes with cervical dilatation and results in obstructed labour, or in delivery at the expense of a deep laceration in the cervix. The injury may extend to involve the lower segment. Cervical dystocia calls for caesarean section.
- Traumatic intrapartum and postpartum haemorrhage. This occurs from tearing of rigid tissues in the cervical stump.

Women in whom the cervix has been amputated should be delivered only in a fully equipped hospital because of the risks to both mother and baby.

### *Colporrhaphy*

The possible effects of this procedure on childbearing are as follows:

- No effect
- Dyspareunia, apareunia, and therefore infertility
- Delay in the second stage of labour. This is due to failure of scar tissue in the vagina and perineum to stretch. The delivery may ultimately be achieved at the expense of extensive perineal tears.

- *Recurrent prolapse:* The chance of prolapse recurring after a subsequent labour is difficult to compute; it varies with the type of operation. After a Manchester operation there is little risk of pregnancy and labour causing a return of prolapse. If, however, anterior colporrhaphy and posterior colpoperineorrhaphy are carried out without amputation of the cervix, as is often the case in young women, there is a high recurrence rate after labour. If the operation has consisted only of perineorrhaphy, vaginal delivery does not usually cause a return of trouble providing episiotomy is carried out.
- Stress incontinence of urine cured by urethropexy and anterior colporrhaphy frequently relapses with a subsequent pregnancy or labour.

Previous colporrhaphy always calls for delivery in a fully equipped hospital. Caesarean section is indicated not less than 20 per cent of all cases and should be made the rule for women cured of urinary stress incontinence. When the vaginal route is chosen for delivery, episiotomy should be carried out as a routine to shorten the second stage and to minimize stretching and tearing of the paravaginal supports.

## PROLAPSE OF THE OVARIES

This is a relatively unimportant example of prolapse. The ovaries can be very mobile but they are not often significantly low in the pouch of Douglas unless they are the seat of a tumour, or unless there is an associated retrodisplacement of the uterus. The only symptom likely to be produced is occasional sharp deep-seated sickening pain when one or other ovary is touched during coitus. This sensation is reproduced by pressure on the ovary during bimanual examination. In fact, deep-seated dyspareunia attributed to prolapsed ovaries is mostly caused by pressure on the associated retroverted uterus.

Symptomatic treatment is preferable; dyspareunia, for example, can nearly always be avoided by modifying coital posture. If an operation is carried out, usually for some other reason, the ovary is usually suspended from the cornu of the uterus by shortening the ovarian ligament, with or without an associated ventro-suspension of the uterus.

# CHAPTER 17

## Other Displacements of the Uterus

Upward Displacement of the Uterus	293
Lateral Displacement of the Uterus	293
Forward Displacement of the Uterus	294
Backward Displacement of the Uterus	294
Retroverted Gravid Uterus	299
Inversion of the Uterus	300

The uterus normally has a limited range of movement, so its position in the pelvis is affected by filling of the bladder and rectum, by increasing the intra-abdominal pressure through coughing, laughing and bearing-down effort, and by alterations in posture. The uterus is lower when the woman is standing than when she is lying, and lowest when she is squatting. Nevertheless, the supravaginal cervix is relatively fixed and movement or displacement of the uterus often consists of rotation of the organ around this axis, or of bending of the corpus on the cervix.

### UPWARD DISPLACEMENT OF THE UTERUS

The uterus can be lifted upwards to become an abdominal organ, and the external os may be above the level of the upper border of the symphysis pubis and out of reach of the vaginal examining fingers.

#### Causes

- A vaginal or paravaginal tumour
- Haematocolpos
- A broad ligament tumour and especially a low cervical leiomyoma
- Any tumour impacted in the pouch of Douglas
- A collection of pus or blood in the pelvis.

#### Treatment

Treatment is directed to the cause, the displacement itself being of no consequence.

### LATERAL DISPLACEMENT OF THE UTERUS

There may be lateral deviation of the uterus as a whole, or lateral tilting with the corpus directed to one side and the cervix to the other. Except as a sign of the lesion causing it, a displacement of this type is of no significance.

## Causes

- A unilateral tumour, inflammatory exudate or collection of fluid, especially if situated in the broad ligament, pushes the uterus to the opposite side.
- Adhesions can pull the uterus to one side. Malkani described the deviation of the uterus and cervix to one side of the pelvis as a sign of genital tuberculosis, wherein post-infection scarring results in contractures and pulls the uterus to the affected side.
- Operative removal of one adnexum often leaves the uterus leaning towards the side of the operation site.
- Unicornuate or bicornuate deformity
- Idiopathic. It is common for the uterus to lie or lean to one side without there being an abnormality (Fig. 17.1). In this case the uterus is mobile and can be manipulated temporarily to a normal position.

## Treatment

No treatment other than that of the cause is necessary.

## FORWARD DISPLACEMENT OF THE UTERUS

Forward displacement of the uterus as a whole is usually the result of a tumour or a collection of fluid in the pouch of Douglas, and is then associated with upward displacement. It can also be explained by a previous ventrofixation operation. Acute antelexion of the *uterus*



Fig. 17.1: Lateral deviation of the uterus, which is common and not significantly abnormal

(or forward displacement of the corpus) is not to be confused with acute antelexion of the *cervix* (cochleate uterus). It is a normal finding in early pregnancy when the fundus is heavy and the supravaginal cervix is soft and atonic. A fundal leiomyoma or an ovarian tumour can push the corpus downwards.

These displacements have no importance in themselves. This was not recognised in bygone centuries, and it is of interest to recall that one of the early uses of mechanical pessaries was to correct anteversion, even normal anteversion, rather than retroversion.

## BACKWARD DISPLACEMENT OF THE UTERUS

Backward displacement of the uterus as a whole (*retropronation* or *retroposition*) is the normal reaction to a full bladder and can be caused by any tumour occupying the front compartment of the pelvis. It also occurs as a developmental peculiarity in certain women. In no circumstances is it of any significance. More important are the states of *retroversion* and *retroflexion* with which the remainder of this section is concerned.

## Definitions

**Retroversion:** In this condition the axis of the *cervix* is directed upwards and backwards in relation to a line drawn through the long axis of the trunk (Figs 17.2C, D, E).

**Retroflexion:** In this condition the long axis of the *corpus* is *bent* backwards on the axis of the *cervix* (Figs 17.2 C, E, F).

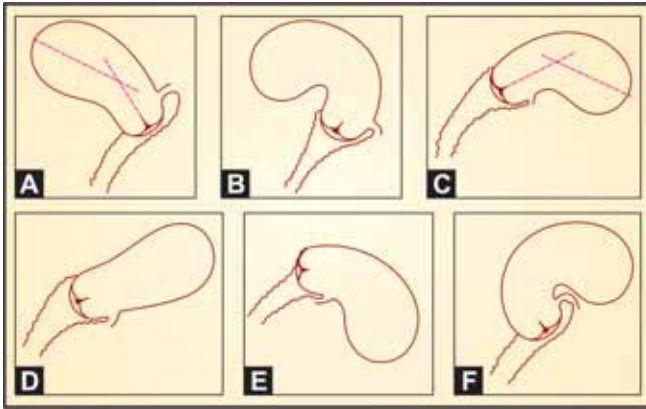
According to these definitions it is theoretically possible to have retroflexion in an anteverted uterus and antelexion in a retroverted uterus; such states are described although they are of academic interest only. In practice, retroversion and retroflexion usually occur together and they are often both loosely called retroversion or *retrodisplacement*. No attempt is made to separate them here, although it may be noted that, of the two, retroflexion is more likely than retroversion to cause symptoms.

Degrees of retroversion and retroflexion are also described but are of no practical value.

## Frequency

Retrodisplacement of the uterus is found in approximately 15 per cent of women.





**Figs 17.2A to F:** Uterine version and flexion. (A) Normal anteflexion and version. (B) Cochleate uterus or acute anteflexion of the cervix. The axis of the cervix indicates retroversion but the angle of anteflexion is increased so that the corpus is in normal position in the pelvis. (C) Retroversion and retroflexion. (D) Retroversion. (E) Extreme retroflexion and retroversion. (F) Cochleate type of uterus in reverse; an essentially anteverted uterus (from the direction of the cervix) is sharply retroflexed

## Causes

### *Developmental (congenital)*

Retrodisplacement of the uterus is most often a developmental anomaly. It is not a *congenital* malformation because the uterus is without version and flexion at birth. Nearly all cases of retroversion and retroflexion in nulliparous women are of this type, and there is no reason to believe that the same is not true for multiparous women. One physical sign frequently noticeable in these cases is a shallow anterior vaginal fornix; the anterior vaginal wall and cervix appear to be almost continuous. The vagina, too, sometimes appears shorter than average.

### *Prolapse*

As the uterus descends it comes into line with the vagina, that is, it is slightly retroverted. Many declare that the retroversion precedes and favours prolapse but the evidence is flimsy; it can just as well be argued that the prolapse causes the retroversion (Fig. 17.3).

### *Tumours and Adhesions*

A tumour lying in front of the uterus pushes it backwards; adhesions behind may pull it backwards.



**Fig. 17.3:** Second degree prolapse

Endometriosis of the uterosacral ligaments and pouch of Douglas is very commonly found in association with retroversion and is a cause of displacement of a previously anteverted uterus.

### *Puerperal*

Retrodisplacement is often found to be present when the uterus involutes after pregnancy because, as it was once said, it falls backwards while its controlling ligaments are slack and subinvolved. The uterus is certainly unusually mobile and plastic during the weeks after delivery, and I have often noticed that a uterus which is retroverted 3-6 weeks after delivery becomes anteverted within the following months and vice versa.

When the uterus remains *permanently* retroverted after pregnancy, it is generally safe to conclude that it was in a similar position before pregnancy and that it has merely returned to its normal state. This happening explains why puerperal retrodisplacement, even if treated, usually recurs after each pregnancy. It also accounts for the old observation that if retroversion does not occur after the first pregnancy it is unlikely to do so after subsequent ones. Pregnancy and faulty involution are therefore not very common causes of permanent retrodisplacement of the uterus.

## Symptoms

It cannot be emphasised too strongly or too often that a *mobile retrodisplacement of the uterus is nearly always symptomless*, and that it can be regarded as a normal physical trait of many women. Its only real disadvantage is that it favours perforation of the uterus when a sound or other instrument is inserted, in or out of pregnancy.

If, however, the uterus is *fixed* backwards, symptoms are usually present, these being caused by the lesion fixing the uterus rather than by the retrodisplacement itself. These are considered elsewhere.

The *possible* clinical manifestations of a mobile retrodisplacement and their mechanisms are as follows.

### Spasmodic Dysmenorrhoea

Developmental retrodisplacement does not affect menstruation but, if the uterus is cochleate in type, spasmodic dysmenorrhoea can be associated. The symptomatology and treatment are the same as for acute antelexion of the cervix; the retroflexion is incidental and does not need correction.

### Pelvic Congestion Syndrome

When the uterus assumes or resumes a position of retroversion and retroflexion after pregnancy, involution may be slightly retarded, or so it is said. In explanation it is postulated that the torsion of the broad ligament interferes with the venous and lymphatic return, leaving the pelvic organs congested and oedematous.

Persistence of such a circulatory error might later lead to *congestive dysmenorrhoea, menorrhagia, polymenorrhagia, premenstrual low back pain, diffuse suprapubic pain, dyspareunia* and *leucorrhoea*. This is an entirely theoretical concept and it is extremely doubtful whether such symptoms — which are features of the 'pelvic congestion' syndrome are ever attributable to uterine retrodisplacement. They certainly cannot be if the displacement is developmental in origin because the circulation will be adapted to this. Some of these patients have psychosomatic and psychiatric complaints as well.

### Low Backache and Pelvic Pain

Despite statements to the contrary, a mobile retroversion probably never causes these symptoms.

### Rectal Symptoms

Uterine retrodisplacement alone *never* produces pressure on the rectum or symptoms referred to the lower bowel.

### Dyspareunia

This is one of the few genuine symptoms of retrodisplacement but is present in only a minority of cases, depending possibly on the length of the vagina. The pain is deep seated and is caused by direct pressure on the uterus itself rather than on an associated prolapsed ovary. It is position-dependent and change of coital position may avoid or reduce discomfort. Some of these patients may have endometriosis.

### Infertility

Although women with retroversion ordinarily conceive readily, a few find it difficult and it is postulated that this is because the cervix is directed forwards away from the seminal pool, and the ejaculation of semen directly into the external os is less likely. Moreover, the external os tends to be closed by the anterior vaginal wall when coitus is complete (Fig. 17.2E). More importantly, however, some of these women may have associated pelvic pathology such as endometriosis or pelvic inflammatory disease which is the cause of both the retroversion and the infertility.

### Abortion

Contrary to former belief, retrodisplacement of the uterus is not an important cause of abortion, unless the uterus is impacted in the pouch of Douglas and there is a disturbance in the uterine vascularity. In such cases, it may be a factor in a few cases, operating between the tenth and fourteenth weeks.

## Physical Signs

Inspection of the cervix through a vaginal speculum is often enough to make a provisional diagnosis of retroversion. It is characteristic that the cervix comes into view unusually easily and that the external os points forwards. On bimanual examination the position and direction *of the cervix* are again valuable signs, especially if it is difficult to define the corpus.

To be certain of the diagnosis, the body of the uterus should be felt in the pouch of Douglas and recognised by its size, shape and continuity with the cervix. Tenderness is a striking although unexplained feature of the retroflexed uterus, even when there is no associated disease (hence the dyspareunia).

In the past, when more importance was attached to retroversion, uterine position was often confirmed by passing a sound. This is now rarely done except as a precaution preliminary to the insertion of an instrument or an intrauterine contraceptive device.

### Differential Diagnosis

Uterine retroversion and retroflexion have to be distinguished from the following.

- Acute ante flexion of the cervix, confusion arising because of the forward direction of the cervix
- A tubal or ovarian swelling prolapsed in the pouch of Douglas or adherent to the back of the uterus
- Faeces or other mass in the lower bowel
- A tumour such as endometriosis in the pouch of Douglas or in the rectovaginal septum, pelvic haematocele and an abscess
- A leiomyoma or other tumour in the posterior wall of the uterus.

### Management and Treatment

When retroversion or retroflexion of the uterus is diagnosed, it becomes necessary to determine whether the uterus is fixed or mobile. This is done by attempting to replace it *by moving the cervix backwards* and by pushing the fundus upwards. Only very rarely is examination under anaesthesia necessary to ascertain mobility.

When the uterus is fixed, treatment should be directed primarily to the disease causing the fixation and the symptoms. If the patient has other symptoms and limited mobility of the uterus, a laparoscopy may help to establish the correct diagnosis.

If the uterus is found to be mobile, the general conclusion should be that it is not causing symptoms and that no treatment is required. In most of these cases the patient should not even be informed of the presence of the retroversion or, if she is, she should be assured that it is a normal feature of her development.

The possible lines of treatment for uterine retrodisplacement are discussed below.

### Prevention

Preventive measures used to be suggested during the weeks immediately after abortion or labour and they consisted of the following.

- Regular emptying of the bladder to avoid over-distension
- Pelvic floor exercises
- Early ambulation
- Posture. The puerperal woman used to be advised to lie face downwards for ½—1 hour once or twice daily with the idea of encouraging anteversion. If this treatment had any value the most important time for it was between the tenth and twenty-eighth days after labour; before then the uterus is so large that the sacral promontory prevents retroversion.
- Pessary treatment.

*The above is in line with tradition* and, since a puerperal retroversion usually represents merely a return to a prepregnancy state, it does not require treatment of any kind. So, as a rule, the finding should be made without comment, or at most the patient told to report within the first 3 months of her next pregnancy.

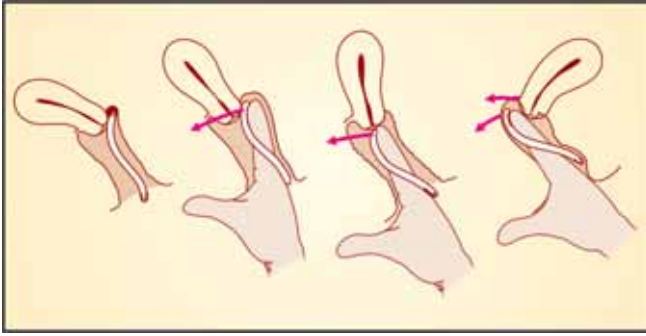
### Replacement of the Uterus and Insertion of A Pessary

#### Principles of Treatment

A supporting pessary inserted into the upper vagina will hold the uterus in normal position *temporarily*, but it cannot cure a retrodisplacement except possibly in the puerperium. The most efficient instrument for this purpose is the Hodge type pessary. The pessary achieves its objective by putting tension on the posterior vaginal fornix and the overlying uterosacral ligaments, and this in turn holds the cervix backwards. *The pessary does not press on the body of the uterus*; this stays forward merely because its backward rotation is prevented by fixation of the cervix (Fig. 17.4). A pessary therefore only exerts its effect after the uterine position has been corrected.

#### Indications for Insertion of a Pessary

A fixed retroversion cannot be replaced and a pessary is therefore of no value in its treatment. A mobile retroversion may be treated with a pessary under the following circumstances.



**Fig. 17.4:** Correction of retroversion by means of a Hodge pessary

### Pessary Test

When there is reasonable doubt whether the symptoms are caused by the displacement, a therapeutic test can be applied. It has to be kept in mind that the insertion of a pessary can have a good effect psychologically in an over-anxious patient with vague complaints, and this possibility has to be excluded. The pessary is put in place and the woman asked to report the effect on her symptoms at the end of one month. No indication is given to her as to whether relief is expected or not. If the symptoms are not improved, the retroversion is blameless and requires no further consideration. If they are improved, the pessary treatment is continued for 2-3 months in all and the device is then removed. At that time the patient is assured that the malposition is corrected and that nothing more is required. In fact, the retroversion recurs immediately but the patient is unaware of this so, if she returns promptly with a recurrence of symptoms, it may be concluded that her observation is without prejudice and that treatment is indicated.

### During Pregnancy

Pessary treatment is rarely required but may be used if the uterus does not correct its own position by the tenth to twelfth week (*see below*).

### Technique of Replacement of the Uterus

- Bimanual manipulation of the uterus is one method, the secret of success being to *move the cervix backwards*. This automatically rotates the fundus forwards until

it can be caught by the abdominal hand and manoeuvred into the final position.

- The easiest and best method is to use the pessary as a lever for replacement of the uterus. This gives the patient very little discomfort, often she does not realise that the uterus is being repositioned. The pessary is inserted while the uterus is still retroverted; its upper rim then lies in front of the cervix. Finger pressure on the upper part of the pessary then forces the cervix backwards and the fundus begins to rotate forwards (Fig. 17.4). As the cervix moves backwards the rim of the pessary slips past and comes to lie in its proper place, the posterior fornix. If anteversion is not then complete, the pessary can be used to pull the cervix further backwards by 'stroking' the upper posterior vaginal wall. An advantage of this method is that there is no opportunity for the retroversion to recur between the replacement manoeuvre and the insertion of the pessary.
- A finger inserted into the rectum may help to push the corpus forwards.

In a difficult case the knee—chest position can be of help. Rarely, general anaesthesia is necessary to allow the manipulation. If the pessary itself is used to lever the uterus into position, anaesthesia is hardly ever required.

### Size of Pessary, Management of Pessary

Has been discussed elsewhere.

## Operative Treatment for Retrodisplacement

### Indications

Operative treatment is rarely necessary and is only indicated in the following circumstances.

- When the displacement has been *proved* to be causing symptoms by an adequately controlled pessary test.
- When a retroflexion is causing severe dyspareunia. This is a definite indication but, even so, an operation can often be avoided by instructing the couple to change coital posture so that the woman's back is towards the man (*coitus a tergo*).
- As part of an operation for an associated condition such as pelvic infection, endometriosis and leiomyoma.
- In a few cases of infertility and habitual abortion when all other causes have been eliminated.

### Techniques

More than 200 operations for retrodisplacement have been described and these include the following.

- Various methods of intraperitoneal looping and shortening of the round ligaments and uterosacral ligaments. In the *Baldy Webster operation*, round ligament loops are passed through the anterior and posterior leaves of the broad ligament stitched together behind the uterus, creating a hammock-like effect.
- Bringing a loop of each round ligament out through the internal abdominal ring and suturing it to the back of the rectus sheath (modified *Gilliam's operation*) using a permanent suture. This again has the effect of shortening the round ligaments. Provided the loops are kept *extraperitoneal*, it is the method which I favour. It has no ill effect on subsequent pregnancy and childbirth.
- Laparoscopic ventrosuspension is favoured by some operators.
- Shortening of the uterosacral ligaments may be attempted at laparotomy and is useful when combined with a modified Gilliam suspension but care must be taken to avoid excessive tucking which can result in kinking or ligation of the ureter and also cause dyspareunia.

### RETROVERTED GRAVID UTERUS

The uterus is retroverted during the early weeks in 15 per cent of all pregnancies.

#### Outcome and Effects

##### *Spontaneous Correction of the Position of the Uterus*

This occurs by the tenth week of pregnancy in nearly all cases. Since many women do not take medical advice before this time, the previous presence of the displacement is often not known. The capacity of the uterus to correct its own position is remarkable. It succeeds even in the presence of adhesions, presumably because they soften and stretch in pregnancy, as evidenced by the following.

Two patients attended a clinic for infertility for years. Both had widespread endometriosis in the pelvis and ultimately laparotomy was carried out. Tarry cysts were dissected from the ovaries but the uterus was fixed

backwards by adhesions which were so dense that it was impossible to separate them without injury to the bowel. The uterorectal pouch was obliterated. Both women had ovulation suppressed for 9 months with a combined oestrogen and progestogen pill. In both cases, the uterus was retroverted and limited in mobility prior to conception. Subsequently both women became pregnant and the uterus in each patient was, of course, still retroverted when seen at the eighth and tenth weeks, respectively. By the twelfth and fourteenth weeks, respectively, each uterus was inclined forward and out of the pelvis. The pregnancy in each case progressed uneventfully.

#### Impaction of the Uterus

##### *Pathology*

Very, very occasionally the fundus of the uterus fails to clear the promontory of the sacrum, and becomes impacted in the pelvis at the twelfth to fourteenth week. The uterus then fills the pelvis and displaces the fundus of the bladder upwards and the base of the bladder forwards. The first symptom may therefore be bladder irritability but the one which usually brings the patient for advice is acute retention of urine. The latter is caused by the tumour interfering with the opening of the internal urethral sphincter posteriorly, not by lengthening and attenuation of the urethra as is so often stated. Acute retention of urine is often precipitated by an episode of excessive drinking, or by a circumstance interfering with the woman emptying her bladder when she first feels the urge. That is, it is brought on by over-distension of the bladder.

Impaction of the pregnant uterus is most likely to occur when the pelvis is small and has an overhanging sacral promontory. The fact that pelvic contraction of severe degree is disappearing probably explains why this complication, once comparatively common is now comparatively rare. A leiomyoma in the posterior wall of a pregnant uterus sometimes determines impaction.

##### *Diagnosis*

The diagnosis can be made with reasonable certainty whenever a woman of reproductive age complains of acute retention of urine associated with 3-4 months' amenorrhoea. On examination, a soft tender tumour is found arising from the pelvis and may be mistaken for the uterus. It is in fact the distended bladder (Fig. 17.5).



**Fig. 17.5:** Retention of urine associated with an impacted retroverted gravid uterus. A multiparous woman with 15 weeks' amenorrhoea complained of inability to void. The uterus was entirely in the pelvis and the abdominal 'tumour' which reached well above the umbilicus was the distended bladder

Vaginally, it is difficult to find the cervix, which is drawn high up in the anterior fornix; behind and filling the pelvis is the tense but soft uterus.

The condition has to be distinguished from all others causing retention of urine, and from other tumours which may occupy the pouch of Douglas — particularly a large haematocele associated with ectopic pregnancy. *Confusion with ectopic pregnancy is a very real possibility* because the presence of some uterine bleeding may be wrongly attributed to threatened abortion associated with the retroversion.

#### Treatment

The immediate treatment is to catheterise the patient and this can be done easily because the urethra itself is not compressed. Care is necessary since rapid release of the contents of an overdistended bladder can cause collapse of the patient. Sudden decompression is also said to precipitate rupture of the rapidly refilling blood vessels of the bladder wall but this theory is no longer acceptable. Haematuria, when it occurs, is evidence of severe cystitis which can even progress to gangrene.

Slow emptying of the bladder, the patient meanwhile being kept prone or in an exaggerated Sims' position, often results in correction of the retroversion. Some authorities say that spontaneous cure *always* occurs

if the catheterisation is properly managed, but this is an overstatement. If correction does not occur, the bladder is kept empty by continuous drainage and a large-sized pessary is inserted into the vagina. This exerts continuous slight pressure in the posterior fornix and backward traction on the cervix, and usually restores the position of the uterus to normal within a few days. Failing this, the uterus may be manipulated by one of the methods described previously, with or without general anaesthesia. It is said that, as a last resort, laparotomy may have to be carried out. I have never encountered a case in which this proved to be necessary, even when the uterus was known to be bound down by adhesions.

#### Sacculation of the Uterus

A very rare outcome is for the fundus to remain beneath the sacral promontory, the pregnancy continuing to grow by expanding the anterior wall of the uterus. This ultimately produces a saccule or diverticulum of the uterus. If this condition passes unrecognised, the main body of the uterus remains in the pelvis throughout pregnancy and acts as a tumour which obstructs the delivery of the foetus from the sacculation. The only safe treatment then for this exceptional state of affairs is by caesarean section.

#### Management of the Uncomplicated Retroverted Gravid Uterus

A practical problem is the management of symptom-less retroversion found during routine examination early in pregnancy. Bearing in mind that the uterus is almost certain to correct itself, many take the view that no treatment is necessary. The only advice necessary is to tell the patient to make sure that she does not allow her bladder to get too full. This is not usually a problem as frequency is often the case in early pregnancy. However if, for example in hot weather, the patient has a lot of fluid to drink, she should be advised to empty her bladder frequently.

#### INVERSION OF THE UTERUS

Inversion is a condition in which the uterus turns inside out, the fundus prolapsing through the cervix. It is rare, interesting but dangerous. Inversion varies in degree from a mere dimpling of the fundus to involvement of the whole uterus and cervix (Fig. 17.6). It is seen in *acute* and *chronic* forms.

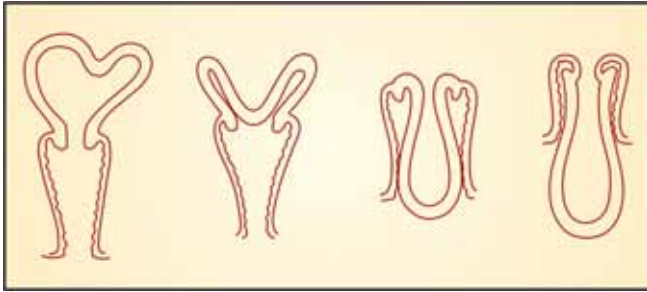


Fig. 17.6: Degrees of inversion

### Acute Inversion

This occurs during, or immediately after, the third stage of labour. The cervix is then open and atonic, and the fundus passes through it because of: mismanagement of the third stage of labour; pressure on the fundus by the attendant; traction on the umbilical cord of an unseparated placenta; or if insufficient time has been allowed for Syntometrine to work effectively in the active management of the third stage. If the degree of inversion is gross, the fundus (with or without the placenta attached) appears outside the vulva.

Otherwise, it remains inside the vagina or the lower part of the uterus and the diagnosis may then only be made by exploring the vagina and uterine cavity with a hand.

Even if it does not cause postpartum haemorrhage, acute inversion nearly always produces a severe degree of shock which can be quickly fatal. It was said that shock is produced by pressure on the ovaries which, together with the fallopian tubes, are drawn inside the inverted fundus (Fig. 17.7). In fact, examination of specimens shows that the ovaries are usually clear of the ring. So the shock is due to cervical distension and traction on the peritoneum and on peritoneal ligaments. It may even come from stimuli arising in the uterine wall itself.

It might be thought that alteration in the height and shape of the fundus would be obvious on abdominal examination immediately after delivery, and thus make the diagnosis easy. This, however, is not the case; the uterine mass generally feels reasonably normal.

Acute inversion is an obstetrical problem and suffice it to say here that the most important part of treatment is to remove the cause of the shock, that is, to anaesthetise the patient and to replace the fundus. This is usually done manually or by hydrostatic pressure obtained by filling the vagina with fluid. Traction on the round ligaments

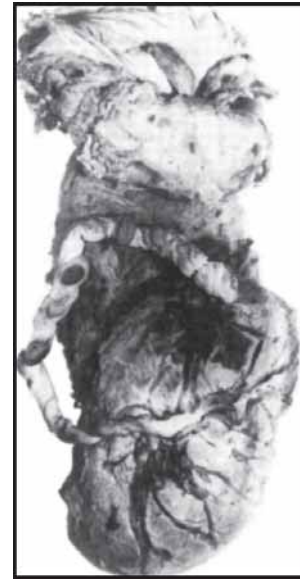


Fig. 17.7: Acute puerperal inversion of the uterus in a woman who died from the resulting shock during the third stage of labour. The autopsy specimen shows the fundus of the uterus completely inverted with the tubes and ovaries dipping into the ring at the top. The placenta is still attached to the inverted fundus.

at laparotomy is only occasionally necessary. The transfusion of blood and other fluids should be carried out simultaneously but by itself is not likely to cure the shock. If attempts to replace the uterus are deferred in the hope that the general condition will improve, they are likely to be forestalled by the patient's death.

Replacement of the uterine fundus under general anaesthesia takes precedence over resuscitation.

### CHRONIC INVERSION

#### PUERPERAL

##### *Pathology*

Occasionally the uterus undergoes incomplete inversion at the time of delivery without producing much shock; or perhaps shock is ascribed to postpartum haemorrhage or other cause, the partial inversion being overlooked. It is also possible that the process of inversion can occur gradually during the puerperium. At any rate, there are cases in which the inversion is 'chronic' in the sense that it is only discovered a few weeks or months after delivery. By that time the exposed endometrial surface is invariably infected and ulcerated (Fig. 17.8).



**Fig. 17.8:** Chronic puerperal inversion with ulceration and infection of the inverted fundus of the uterus. The patient from whom the specimen was obtained was aged 44 years and was treated by hysterectomy when the condition was discovered 3 months after labour.

### Clinical Features

The complaint is vaginal discharge and irregular bleeding dating from a confinement, and there may be a history of postpartum haemorrhage or obstetric shock. Other symptoms are low backache and chronic pelvic pain.

On examination, an infected haemorrhagic mass is found in the vagina and is likely to be confused with a sloughing polyp, a retained portion of placenta, an ulcerated prolapsed cervix and even a malignant neoplasm. The diagnosis is made by recognising that the mass is coming through the cervix, and by demonstrating the shortness of the uterine cavity with a sound.

### Treatment

The first objective is to clear up the infection by keeping the patient lying flat in bed, by douching and by antiseptic packing of the vagina. Occasionally this treatment results in *spontaneous cure of the inversion*. When inversion persists, and when the prolapsed fundus is clean, a special repositor (*Aveling's repositor* or its modification), consisting of a cup on a metal stem, can be placed over the inverted fundus. Continuous pressure is applied by bracing it to the patient's waist and

shoulders. Tight vaginal packing around the cup keeps it in place, and the woman's discomfort is relieved by analgesics. This treatment is generally successful within a few days. One of the secrets of replacing either an acute or chronic inversion is to *lift the uterus high in the pelvis*. This puts traction on the round ligaments which in turn pull the fundus out of the inversion cup. This view, put to Professor Jeffcoate by Dr A.B. Johnson of New York, would explain why filling the vagina with saline solution (O'Sullivan's method), and the repositor, achieve their effect; it would also account for spontaneous cures with posture and vaginal packing.

More commonly however, the uterine fundus can often be lifted up into place by traction on the round ligaments at laparotomy. This procedure is also applicable to acute inversion.

In longstanding and resistant cases, replacement may require incision of the constricting ring of the cervix. This can be done abdominally (Haultain's operation) or vaginally (Spinelli's operation). The former is more common.

Hysterectomy, vaginal or abdominal, may be indicated, especially if further childbearing is not important to the patient.

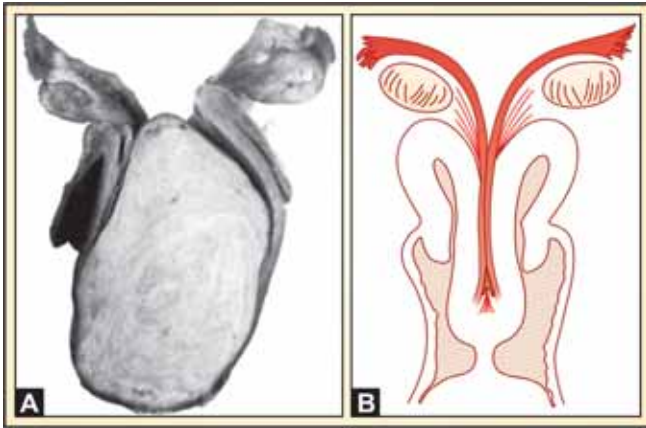
### Senile Inversion

Spontaneous inversion of the uterus is sometimes seen in old age, especially if the cervix has previously been amputated at a high level (Fig. 17.9). The inversion is



**Fig. 17.9:** Spontaneous inversion of the uterus associated with recurrent prolapse. The patient concerned was senile and had had a Manchester operation several years previously. The factors causing the inversion are probably high amputation of the cervix and senile change in the tissues





**Figs 17.10A and B:** Inversion of the uterus caused by tumours, (A) A fundal leiomyoma is the cause in this case; the specimen is unusual because the tumour is not polypoidal. (B) Diagrammatic representation of the more common type of leiomyoma causing inversion

probably due to cervical atony and incompetence. The symptoms and signs are the same as those of chronic inversion. The condition is usually mistaken for ulcerated prolapse. Hysterectomy is the best treatment.

### Inversion Due to Pedunculated Tumour

When a tumour (usually a myoma) arises by a stalk attached to the interior of the uterus, it tends to be expelled into the vagina. If the pedicle is stout and reluctant to stretch, the traction produces a dimple in the uterine wall and ultimately quite a severe degree of inversion (Figs 17.10A and B). The patient's symptoms are those of the polyp and the associated inversion may be missed unless the possibility is kept in mind. If it is overlooked, the result can be disastrous because, in dividing what is regarded as the pedicle of the polyp (Fig. 17.11), the surgeon cuts across the fundus of the uterus and opens into the peritoneal cavity. Before any such polyp is removed, *the length of the uterine cavity*



**Fig. 17.11:** Figure shows a polyp projecting from the os



**Fig. 17.12:** Figure shows a prolapsed gravid uterus which is replaced and kept in place by a pessary

*should always be tested by sound.* Moreover, if there is any possibility of an inversion being present, the tumour should be removed by shelling it from its capsule rather than by dividing its pedicle. Rarely gravid uterus may prolapse completely and these have to be pushed back and treated conservatively till delivery, by the use of pessary (Fig. 17.12).

# CHAPTER 18

## Torsion of Pelvic Organs

Torsion of the Normal Organs	304
Torsion of Abnormal Organs	305
Aetiology	305
Differential Diagnosis	307
Treatment	307

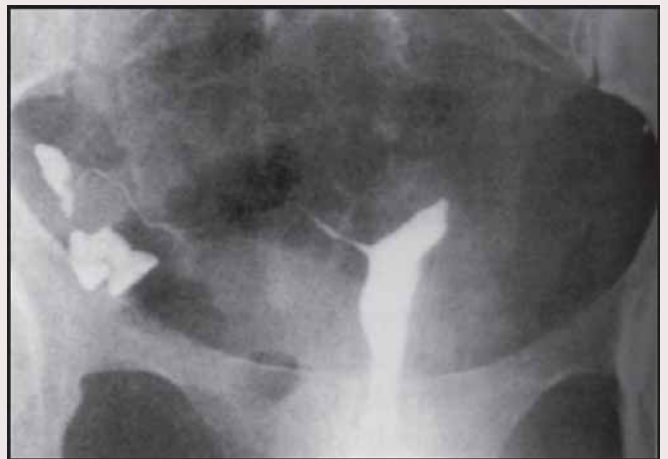
### TORSION OF THE NORMAL ORGANS

#### Uterus

A minor degree of rotation of the uterus around its long axis is common and insignificant (Fig. 18.1). It is seen especially in pregnancy when the twist is nearly always to the right, that is, clockwise as seen from above. Torsion sufficient to obstruct the blood supply probably never occurs in the *normal* uterus.

#### Tube and Ovary

Torsion of the normal ovary alone is exceptional, but torsion of the normal fallopian tube with or without the ovary is not very rare. Sometimes only the free outer end of the tube is involved. The torsion may be partial and self-correcting but it then tends to recur. In the fully developed condition the tube can undergo several complete turns. The effect is first to obstruct the venous return, causing extreme congestion and extravasation of blood. Ultimately the arterial supply is affected and the tissues distal to the twist become gangrenous.



**Fig. 18.1:** Rotation of the normal uterus as revealed by hystero-gram. The degree of twist is not of significance but radiographs showing this sort of picture are often misinterpreted as showing a uterine malformation

The patient is usually a child or an adolescent. She complains of a sudden onset of severe pain in the lower abdomen, to one or other side of the midline. This may be intermittent with a previous history of a similar pain. It can cause vomiting, and sometimes bladder and bowel irritability. Shock is rarely present, the temperature remains normal at first but the pulse rate may be raised. Slight uterine bleeding often occurs within a few hours. Muscle guarding or rigidity over the lower abdomen is usual. Since the patient is nearly always young and virginal, pelvic examination is difficult. Rectally there may be tenderness to one side of the uterus but the swelling of the adnexa is usually too small to feel.

The clinical features are those of a twisted ovarian cyst without a tumour being found. When these occur in a young girl the diagnosis should always be entertained, although it cannot be made for certain without laparoscopy or laparotomy.

### TORSION OF ABNORMAL ORGANS

This is much more common than is torsion of normal organs.

#### Uterus

Symptom-producing significant degrees of torsion of the uterus, either pregnant or non-pregnant, only occur when the uterus is *asymmetrical* because of a tumour or müllerian duct fusion deformity, or when it is twisted by an adjacent lesion. The torsion is usually at the level of the supravaginal cervix so the uterine vessels are obstructed; the uterus then becomes engorged, infiltrated with blood, and ultimately gangrenous.

The condition is rare. The patient complains of severe abdominal pain of sudden onset, and this is followed by shock which may be fatal. Vomiting and slight uterine bleeding are usual. Muscle guarding and uterine tenderness are found on examination.

#### Pedunculated Leiomyoma

Torsion of the pedicle of a subserous leiomyoma is common.

#### Tube

The lesion of the tube preceding torsion is mostly a hydrosalpinx. The interference in blood supply converts this to a haematosalpinx. The clinical features are the

same as for torsion of the normal tube except that a tumour is more likely to be found on examination. At operation it is often difficult to say whether the tube was previously normal or the seat of a hydrosalpinx (Fig. 18.2). Torsion of the tube can occur with the rare carcinoma of the fallopian tube.

Torsion of the tube also inevitably occurs when there is torsion of a paraovarian (fimbrial) cyst because the tube is tightly stretched over the wall of the cyst.

#### Ovary

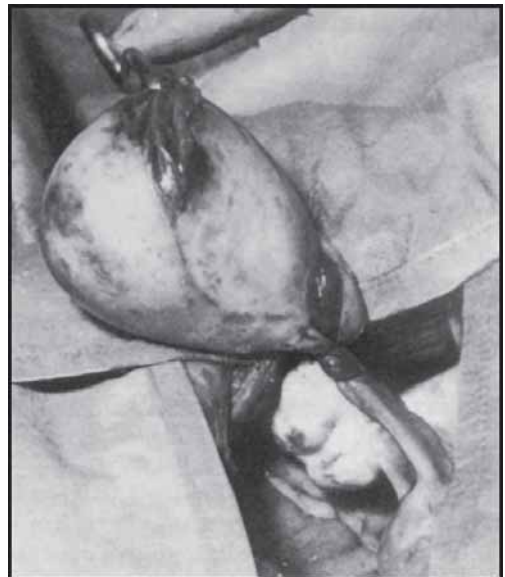
Ovarian tumours are commonly complicated by torsion of their pedicle and part or all of the tube may be involved as well (Figs 18.3 and 18.4). Involvement of the ovary in torsion of a hydrosalpinx or fimbrial cyst depends on the exact site at which the twist occurs in relation to the mesovarium.

### AETIOLOGY

The factors determining the axial rotation of organs and tumours are as follows.

#### Unusual Mobility of Organs

Physiological mobility of organs in childhood and adolescence explains why torsion of a *normal* tube and



**Fig. 18.2:** Spontaneous torsion of the outer end of a fallopian tube, possibly the site of a hydrosalpinx. Below the tube is a normal and uninvolved ovary containing a recent corpus luteum



**Fig. 18.3:** Torsion of solid ovarian tumour

ovary is mostly seen at these ages. Instability of the outer end of the tube, caused by resection of the middle portion for purposes of sterilisation, can also result in its torsion (Figs 18.5A and B). For similar mechanical reasons it is the small rather than the large tumour, with a long pedicle, which is most likely to be affected by this complication.

*Asymmetrical growth* of a tumour may determine the initial twist.

### Pregnancy and the Puerperium

Torsion of tumours is more often seen during pregnancy or in the puerperium when abdominal wall tension and intra-abdominal space are altering rapidly. Changes in the size of the uterus also act as rotating forces.

### Movement of the Trunk

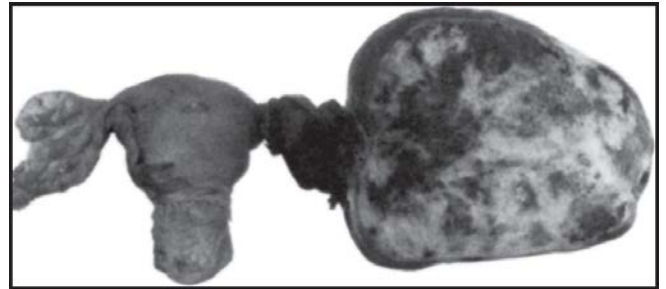
Torsion can be started by certain movements and often appears to follow turning over in bed.

### Defaecation and Micturition

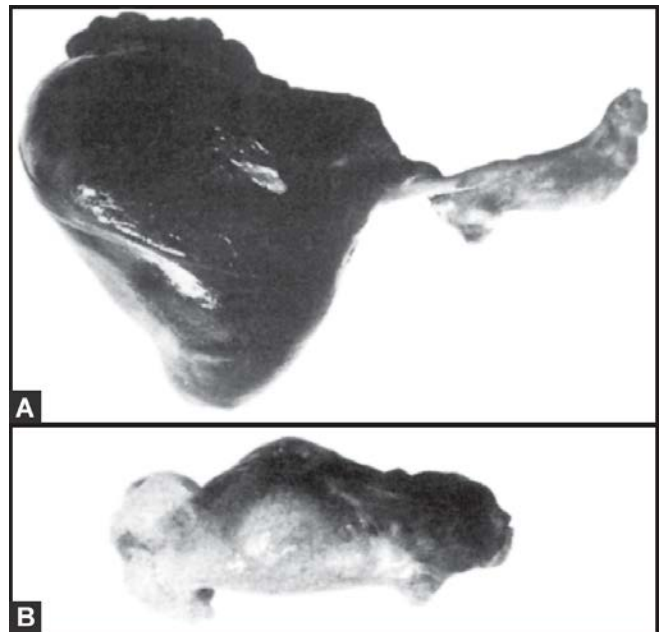
These can operate by altering intra-abdominal relations.

### Adhesions, Bands and Tumours in Adjacent Organs

A normal fallopian tube can become twisted around a ventrofixation band. This sort of accident is described after various operations for uterine retroversion.



**Fig. 18.4:** Torsion of the pedicle of a solid ovarian tumour (granulosa cell). The fallopian tube is involved in the torsion. Note the extravasation of blood throughout the tissues distal to the twist



**Figs 18.5A and B:** Acute torsion of the outer half of one fallopian tube following division of the tube as part of a Pomeroy sterilisation operation. The two segments of the tube are shown, the inner one being unaffected while the outer one has twisted on its broad ligament attachment and is distended with extravasated blood. Below is the outer part of the other unaffected tube for comparison

Whatever be the force which commences the rotation of the pedicle or mesentery, it is widely believed that the further twisting is brought about by haemodynamics—possibly by pulsation in the vessels supplying the tumour or organ.

### Idiopathic

In many cases there is no obvious cause.

### DIFFERENTIAL DIAGNOSIS

Torsion of a pelvic organ or tumour has to be distinguished from: acute salpingitis; ruptured cyst; ectopic pregnancy; all causes of intraperitoneal haemorrhage; acute appendicitis and diverticulitis; rupture of an endometriotic cyst; ovulation pain; degeneration in a leiomyoma; retroplacental haemorrhage during pregnancy; intestinal obstruction; and renal colic.

Before operation it may be impossible to say which organ or tumour has undergone torsion, although guides are offered by the age, previous history and

menstrual function of the patient, and by the position of a tumour.

### TREATMENT

If torsion is suspected or diagnosed, immediate laparotomy is required; the surgical procedure then depends on the exact nature of the findings. If the torsion is incomplete or recent, the tissues may still be viable; it is then possible to conserve them and to stabilise them by suture. Ovarian cystectomy, as distinct from removal of the whole ovary with its tumour, is sometimes a reasonable procedure. If the organ has undergone more than 3 twists, blood supply is occluded beyond correction. When the tissues are gangrenous or beyond recovery, they have to be removed.

# CHAPTER 19

## Infections Including STD

The Natural Defences of the Genital Tract	308	Sarcoidosis	330
Sexually Transmitted Diseases	310	Actinomycosis	331
Other Sexually Transmitted Infections	316	Schistosomiasis (bilharzia)	331
Genital Tuberculosis	323	Amoebiasis	332

### THE NATURAL DEFENCES OF THE GENITALTRACT

The genital tract forms a continuous open pathway from the exterior to the peritoneal cavity, and a natural defence system against ascending infection is therefore necessary. This is all the more important in view of the proximity of the urethra and anus to the vaginal orifice.

#### Defence Mechanisms

##### *Vulva*

The vulva and perineum of the mature woman have a remarkable inherent resistance to infection; so incisions and tears, even if contaminated, heal well if sutured with care over haemostasis. Additionally, the secretion of the apocrine glands is said to be rich in undecylenic acid which is fungicidal. These properties, as well as closure of the introitus by apposition of the labia, protect the genital tract above.

##### *Vagina*

- Closure by apposition of its anterior and posterior walls.
- A well-developed stratified squamous epithelium, unbroken by entrances to glands.
- Vaginal acidity.
- *Vaginal flora*: All manner of organisms ordinarily inhabit the vagina but the Gram-positive anaerobic lactobacillus is normally predominant and it is this which, by its production of lactic acid, keeps the others in check. The efficiency of the vaginal defence is directly proportional to the relative number of lactobacilli present. Organisms that do not attach to the underlying tissue are swept away by the mucus stream and do not produce tissue damage or local inflammatory response. Glycoprotein and carbohydrates seem to be the factors responsible for adherence.

- The mucosal immune response - antibodies are present although titres are low. Phagocytic cells and cytokines have also been identified.

### Cervix

Functional closure of the cervix is effected by mucus which is also said to be bacteriolytic.

### Uterus

Periodic shedding of surface endometrium during menstruation tends to eliminate any infection which may try to gain a hold. The cavity of the uterus was formerly regarded as being sterile but it is now known that it often harbours non-pathogenic anaerobic streptococci, especially after abortion and labour. These may well play a beneficial scavenger role in clearing away debris after menstruation and pregnancy.

### Variations in the Efficiency of Defence Mechanisms

#### With Age

The defences are imperfect during childhood and after the menopause when the vagina has thin and vulnerable epithelium, when its content of glycogen and lactobacilli is low, and when its pH approaches 7. The endometrium is also poorly developed or atrophied at these ages and does not undergo cyclical shedding and reformation.

#### With Menstruation

During menstruation the cervical plug is absent and vaginal acidity is lowered by the alkaline menstrual discharge. Gonococcal infection is therefore more virulent if contracted during menstruation and is more likely to ascend to the uterus and tubes at that time. Similarly, *Trichomonas* vaginitis tends to occur or relapse during menstruation.

#### During the Puerperium

In the adult woman the genital tract defences are weakest during and immediately after abortion or labour because: there is a raw placental site; there are often breaks in the epithelial linings of the cervix and vagina; the tissues are bruised and devitalised; the vulva, vagina and cervix are wide open; the discharge of liquor and lochia (both alkaline) reduces vaginal acidity; degenerating blood

clots and fragments of decidua offer a nidus for infection; and the patient's general resistance is lowered by the strain of pregnancy and possibly by anaemia and malnutrition.

These circumstances are the basis of what was, in the past, the scourge of midwifery - *puerperal sepsis* - and which, with the development of antibiotic resistance by organisms, is again becoming a threat (Figs 19.1 and 19.2).

### Types of Infecting Organisms

The organisms commonly causing infection of the genital tract are *Treponema pallidum*, *Neisseria gonorrhoeae*, *Gardnerella vaginalis*, *Haemophilus ducreyi*, *Prevotella* spp., *Bacteroides*, *Peptostreptococcus*, *Calymmatobacterium granulomatis*, *Chlamydia trachomatis*, *Mycobacterium tuberculosis*, the parasite *Trichomonas vaginalis*, *Candida albicans*, the viruses herpes simplex virus (HSV) types 1 and 2, human papillomavirus (HPV) and the greatest scourge of recent times - the human immunodeficiency virus (HIV).

Almost all the pathogenic organisms known, however, can be responsible at times and those worthy of mention are: *Streptococcus* (aerobic and anaerobic, haemolytic and non-haemolytic species), *Staphylococcus*, *Pneumococcus*, *Escherichia coli*, *Clostridium tetani*, *Clostridium welchii*, *Salmonella typhi* and *S. paratyphi*, the

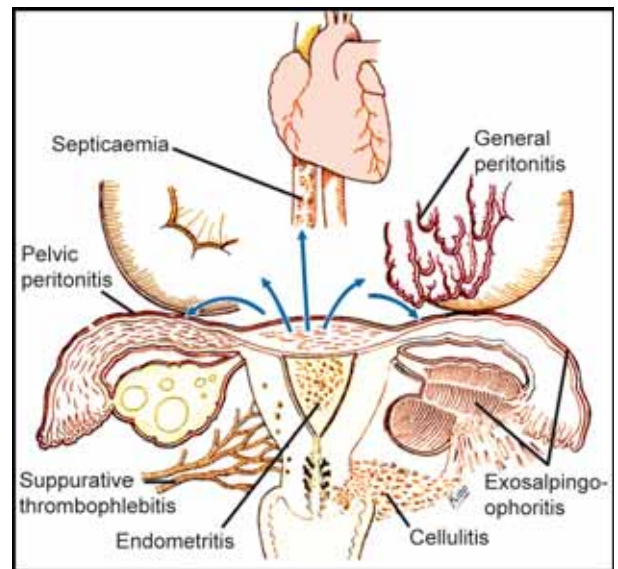
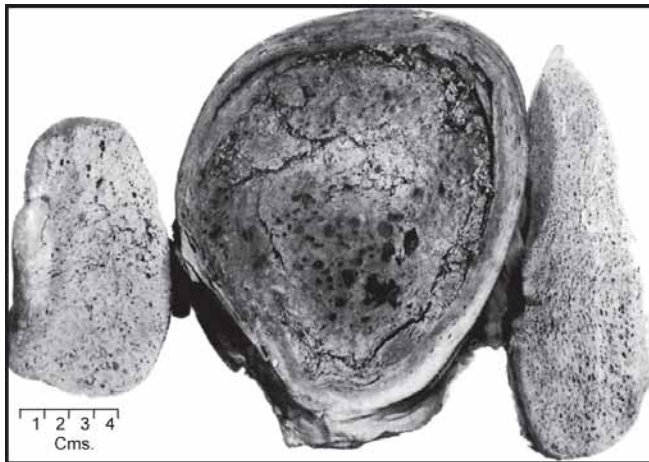


Fig. 19.1: Diagrammatic representation of the mode of spread and lesions produced in puerperal (including postabortal) infection



**Fig. 19.2:** Puerperal infection caused by *Clostridium welchii*. A primigravida aged 20 years was found to be suffering from hydatidiform mole and bougies were inserted into the uterus in an attempt to induce labour. The patient died 4 days later with signs of an overwhelming infection. This was in the days prior to the discovery of sulphonamides and antibiotics. The specimens obtained at autopsy are, from left to right, a portion of the spleen, the uterus with the products of conception still retained and a slice of liver. All the tissues are riddled with gas-containing spaces

actinomycetes and other *Streptothrix* organisms, the filarial worms, *Schistosoma haematobium*, and amoebae.

Many of the above organisms, even *Cl. welchii*, are frequently found in the vagina without being pathogenic. Their presence may represent either a normal or a carrier state.

## SEXUALLY TRANSMITTED DISEASES

Sexually transmitted diseases, also called venereal diseases, after Venus, the Greek goddess of love, are infections acquired during heterosexual or homosexual intercourse with an infected partner. Historically, they comprised only gonorrhoea, syphilis and chancroid. Several other diseases can, however, be sexually transmitted although other modes of origin are possible.

The true incidence of sexually transmitted diseases (STDs) is difficult to determine and all figures are an underestimate, as 80-90 per cent of cases are treated privately and not reported. Throughout the world increasing numbers of cases of syphilis and gonorrhoea are being reported annually along with other STDs. One important factor is that worldwide there are more people at risk each year. The expectation of life has increased, especially for women, so that the lowering of the age of

puberty combined with a longer span of healthy life provides a much greater period for acquiring STD.

The incidence of STD is rising. The commonest condition is a non-specific genital infection (urethritis in the male), with *Chlamydia trachomatis* probably responsible for 40-50 per cent of these cases. Reports from major cities in Europe, the UK and the USA reveal that up to 70 per cent of all cases of primary and secondary syphilis are in homosexual males.

The introduction of penicillin and other antibiotics has had a marked effect on some of the STDs. For instance, gummatous, cardiovascular and neurological syphilis, as well as congenital syphilis, are now rare.

However, indiscriminate use and inadequate doses of these drugs have resulted in the development of resistant strains of the gonococcus so that control of the disease may prove to be difficult in the future.

Improvement in diagnostic methods and increased interest in STD have revealed other sexually transmissible agents, several of which are viral. The manifestations of this group of diseases vary from local discomfort to chronic disability, infertility, ectopic gestation, stillbirth and neonatal death. Cases of urethritis and cervicitis due to *Chlamydia*, *Gardnerella* and other agents greatly outnumber new cases of gonorrhoea and are increasing rapidly.

Many patients with STD are between 18 and 24 years and in recent years there has been a marked increase in the number of girls aged between 16 and 17 years. The radical changes in attitudes to sex and in sexual behaviour during the past 25 years has resulted in a marked increase in STD. This is the price which girls and women everywhere are paying for their sexual liberation.

The reasons for the world crisis in STD are as follows:

- **Promiscuity:** This, the weakening of family life and the fact that modern conditions of life provide more opportunity for promiscuous behaviour are the most important factors. With so many individuals in any community having asymptomatic infections, it requires relatively few partners before an infected one is encountered
- Modern methods of contraception, such as the oral contraceptive pill and intrauterine contraceptive devices, do not offer protection as did the older barrier methods, and at the same time they may encourage casual intercourse
- The development of antibiotic-resistant organisms



- Shifts in the population and overseas travel
- The increase in world population and in life expectancy
- Ignorance of the risk of becoming infected. The youth of today, especially in urban areas, is generally better informed on all matters pertaining to sex. But many refuse to accept that STD is anything more serious than the common cold and believe that it is readily cured without leaving any permanent ill effect. They adopt towards it an attitude of indifference if not contempt.

## Syphilis

### Aetiology

Syphilis is caused by a spirochaete, *Treponema pallidum*, and this organism is to be found in all lesions — primary, secondary and tertiary. The disease is sometimes congenital but is usually acquired by direct contact with another person who has an open primary or secondary syphilitic lesion. The site of infection may be on the hands as a consequence of touching a syphilitic lesion, a risk to which doctors and nurses are especially exposed if there is a break in their skin or mucous membrane. Ordinarily, however, the entry of the spirochaete is determined by sexual contact with an infected partner. This is true even when the primary lesion is on the breast, in the mouth or on the lips, the last sites being determined by genitoural coitus rather than by kissing or by drinking from infected containers - as used to be suggested.

Here we are mainly concerned with syphilitic lesions of the female genital tract acquired as a result of sexual intercourse.

## Clinical Features

### Primary Stage

The primary lesion or *chancre* is found most commonly on the labium majus, labium minus, fourchette, clitoris, urethral orifice or cervix, but it may be anywhere on the lower genital tract, even the vaginal wall. In 10 per cent of cases, more than one primary lesion is present. The chancre usually appears 10-20 days after exposure but the incubation period may be as long as 90 days. The first manifestation is a small papule which quickly breaks down to form an ulcer, the classical features of which are a sharply defined serpiginous outline and a brownish red colour. In practice, however, the lesion is often so

slight that it passes unnoticed, and it rarely has the characters of the typical chancre with a hard base as seen in the male. Indeed, any sort of discrete relatively *painless* ulceration on the vulva may be a primary syphilitic lesion. An inflammatory reaction in the surrounding tissues is unusual but oedema can be present.

On the cervix, a chancre commences as a grey or purple nodule but, when it ulcerates, can resemble an erosion and be mistaken for one. Sometimes it presents as a diffuse induration of the cervix.

The inguinal glands enlarge when the primary is on the vulva or lower vagina. They are hard and shotty but painless, and do not suppurate.

### Secondary Stage

The primary chancre heals spontaneously in 1-8 weeks and soon afterwards the secondary stage of syphilis, which results from entry of the spirochaetes into the bloodstream, is manifested by: general systemic upset with lassitude, anorexia, headaches and pyrexia which is usually less severe than in the male; macular, papular or pustular skin rashes which are typically non-irritant, pleomorphic, bilaterally symmetrical in distribution and copper coloured; occasional loss of scalp hair; white mucous patches in, or ulceration of, the mouth and pharynx; generalised adenitis - symmetrical enlargement of the epitrochlear glands is said to be diagnostic; iritis; and *condylomata lata* on the vulva and around the anus—these differ from the common multiple warts (*condylomata acuminata*) in that they are coarse, flat-topped, moist and necrotic (Fig. 19.3).

Sometimes secondary manifestations occur before the primary heals, or they may not occur at all. The first and second stages can last up to 2 years, during which time the woman is a source of infection.

### Tertiary Stage

In untreated syphilis this stage occupies many years during which the spirochaetes attack bones, joints, eyes, blood vessels, the heart and the central nervous system. Tertiary syphilis is also characterised by the formation of localised granulomas (gummas) in any part of the body. Gummas of critical organs like the heart, brain and liver can be fatal. Gummas of the genital tract are rare, but when they do occur, are most often found on the vulva where they break down to form ulcers with a serpiginous outline and surrounding oedema. They are



**Fig. 19.3:** Secondary syphilitic lesions on the vulva. These consist of brownish, slightly raised plaques and a few flat-topped coarse condylomas

not painful unless secondarily infected. These late forms are rarely seen nowadays.

#### *Latent Syphilis*

After infection with *T. pallidum* there are periods when the patient is seroreactive but shows no evidence of disease. They should all be evaluated for signs of tertiary disease.

#### Diagnosis

The diagnosis during the primary stage is made by examining serum from the base of the primary chancre for the presence of *T. pallidum*, using dark-ground illumination microscopy. Treponemes can also be seen in fluid from most lesions of secondary syphilis. Routine culture of the organism is not yet possible. Serological tests are positive in all but the earliest stage of primary syphilis (they are negative until about 2 weeks after the appearance of the chancre, i.e. about 3-5 weeks after infection) and sometimes in very late syphilis. In suspected congenital syphilis or when the infection has progressed beyond the second stage, the diagnosis can

only be determined by serological tests. The serological tests for syphilis may be grouped into those which are non-specific or non-treponemal and those which are specific or treponemal. Most laboratories carry out a test of each type. The non-specific tests are complement fixation or flocculation tests. The Wasserman (WR) test was the prototype of complement fixation tests and in its various modified forms remains the mainstay of this type of test. A flocculation type of test for a non-specific antibody, reagin, namely the Venereal Disease Research Laboratory (VDRL) slide test, is the most commonly used non-specific test for screening purposes.

The VDRL test may be positive in the absence of specific tests, i.e. a biological false-positive reaction. This can occur in pregnancy, during or shortly after any infective illness such as infectious mononucleosis, measles, chicken pox, mumps, herpes simplex, herpes zoster or viral pneumonia, or following recent immunisation. The false-positive reactions are of a temporary nature but may persist in certain chronic diseases such as leprosy, tuberculosis and autoimmune diseases (lupus erythematosus, haemolytic anaemia, thyroiditis and rheumatoid arthritis).

Antibody to cardiolipin is also measured by the rapid plasma reagin (RPR) test. Although this is an autoantibody (hence the term 'non-treponemal antibody') it provides a useful marker of activity of disease and is helpful in follow-up, especially where only a few samples are being run at a time.

The VDRL test is used in conjunction with specific tests for treponemal antibody, e.g. the *Treponema pallidum* haemagglutination (TPHA) test, to confirm or refute the findings of the non-specific test.

Tests should be repeated after 2 or 3 weeks to ensure that no test has become positive during that time, as can occur in early syphilis. In high-risk situations, repeating the test in the third trimester of pregnancy is recommended. Once positive, the VDRL may remain positive for life.

All serological tests may be negative despite the presence of a primary lesion. The TPHA test will be positive in the secondary stage but only in about 60 per cent of patients with primary syphilis. It is also the last test to become positive. The specific tests do not distinguish the different treponemal conditions; they only distinguish between treponemal and non-treponemal disease.

Interpretation of the serological tests may be difficult if there is a past history of other treponemal infections, particularly the non-venereal tropical disease yaws which is endemic in the West Indies. The causative organism of yaws, *Treponema pertenue*, is morphologically identical to *T. pallidum* and gives indistinguishable serological results. As well as giving positive serological tests, this disease also has three stages — primary granulomas or papules, de-squamation, and ulceration - and can cause visceral and periostotic lesions. The skin lesions are commonly seen on the vulva, breasts and legs. In the absence of a satisfactory history of treatment for yaws the patient should be regarded as having a treponemal disease which might be syphilis and treated accordingly.

### Treatment

The treatment of syphilis is a matter for the specialist venereologist.

Local treatment is useless because the spirochaetes invade deeply and spread by vascular channels at an early stage. The best medication for early syphilis is penicillin to which the treponemes have not so far developed a resistance. A single dose of 2.4 million units of benzathine penicillin intramuscularly appears to cure primary or secondary syphilis. If there is any doubt about the duration of disease or where it is known to have been present for longer than a year, 3 weekly doses are recommended. Intramuscular injection of 600000 units of aqueous procaine penicillin daily for 8 days is equally efficient. The treponemes usually disappear from active lesions within 24 hours, and serological tests become negative in weeks or months. Observation for 2 years following treatment is desirable.

For patients sensitive to penicillin, ceftriaxone (1 g i.v. on alternate days for 5 doses), oxytetracycline (500 mg 6-hourly for 30 days) or erythromycin (500 mg 6 hourly for 30 days) may be substituted. Late syphilis is also treated with penicillin, but the schemes of dosage and number of courses vary with its manifestations. Treatment should be preceded by radiological examination of the heart and aorta, and by tests on the cerebrospinal fluid.

The rare Jarisch-Herxheimer reaction is a minor acute febrile reaction of this type accompanied by headache, myalgia and other symptoms which occurs in 50 per cent of patients after the *first* administration of any therapy

for syphilis and warning of this should be given. It is seen particularly when there are lesions in the larynx, meninges, heart and aorta, but can be seen in one-third of patients of primary syphilis and two-thirds of secondary syphilis. Therapy need not be discontinued. Most cases can be managed by reassurance of the patient and administration of ibuprofen or aspirin. Prednisolone is not usually necessary.

In pregnancy, the treatment is the same as above. The woman who is allergic to penicillin should be treated with ceftriaxone. Erythromycin does not reliably cure the foetus. The baby should be assessed at birth, and at 6 weeks and 3 months after birth.

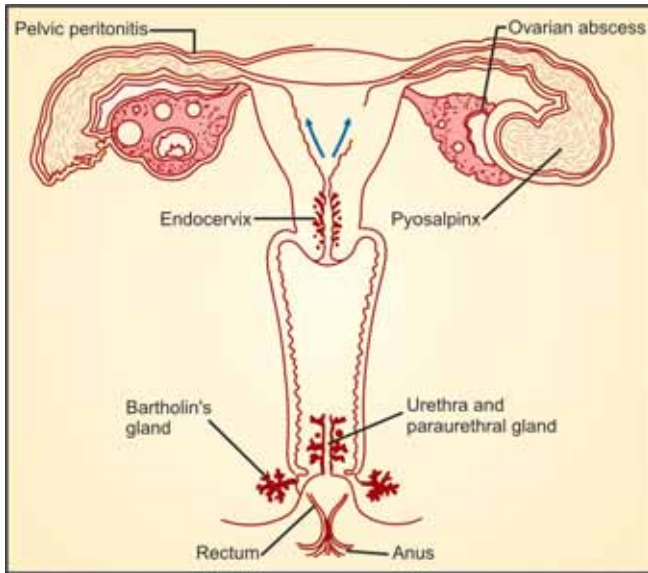
### Gonorrhoea

#### *Pathology and Clinical Features*

Gonorrhoea is an infection caused by a Gram-negative diplococcus - *Neisseria gonorrhoeae* (the gonococcus)—and, in the adult woman, is contracted by sexual contact with an infected male. Transfer by other means is little more than a theoretical possibility except in babies, who can be infected during their passage through the birth canal, the most serious result being ophthalmia neonatorum. There is usually an interval of 2-5 days between exposure and the development of symptoms, but this interval varies from 1 to 10 days. However, an asymptomatic carrier state can persist for weeks or even months and throughout this time infection can be transmitted. The bacteria attack first those tissues of the lower genital tract which are not covered by stratified squamous epithelium - the endocervix, the urethra (including the paraurethral tubules) and the ducts and acini of Bartholin's glands (Fig. 19.4). Gonococci also commonly spread to the anorectum; they may sometimes be implanted there during anal coitus.

The initial complaints of the patient are a purulent vaginal discharge, dysuria and frequency. This discharge causes soreness but not pruritus unless there is an associated *Trichomonas* infection. In severe cases the whole vulva becomes reddened and swollen (Fig. 19.5).

When the vulvar reaction is acute, inguinal adenitis is the rule and some constitutional upset is likely. Cystitis and proctitis can develop. In exceptional cases gonococcal septicaemia is described and may be manifested by pyrexia and even a vesicular or pustular dermatitis. Gonococcal tonsillitis or pharyngitis occurs as the result of genito-oral contact. Lesions involving



**Fig. 19.4:** Diagrammatic representation of the mode of spread and the sites of infection in gonorrhoea



**Fig. 19.5:** Acute gonorrhoea with right-sided Bartholinitis and associated oedema of the labia. The purulent discharge can be seen escaping from the vagina

joints, tendons and ligaments, once regarded as gonococcal, are usually explained by an associated non-gonococcal infection (*see* Reiter's disease) but gonococcal arthropathy does occur and the organisms can be cultured from the joint effusion.

Generally the infection remains limited to the lower genital tract but, in 10 per cent of cases of proven gonorrhoea, it spreads upwards to cause salpingo-oophoritis of varying degree. The organisms ascend through the uterus to the tubes, producing a fleeting acute endometritis on the way. The last is not clinically evident, being overshadowed by the symptoms of salpingitis. Both tubes are always involved and the essential lesion is an *endosalpingitis*. The organisms pass through the abdominal ostia to produce pelvic peritonitis and oophoritis. Generalised peritonitis is rare. It has long been the belief of gynaecologists that gonococcal salpingitis is a self-limiting disease in that the bacteria in the tubes die within 3-4 weeks. Nevertheless, positive cultures are sometimes obtained as long as 6 months after the original infection.

Moreover, even if the gonococci die out, a pyosalpinx is often secondarily infected. The pathology of gonococcal salpingo-oophoritis is described in Chapter 20.

The above is the classical clinical picture of gonorrhoea with some of its rare and even bizarre

variations. It must be emphasised that it is not often encountered. Most women, even in the acute and subacute stages of the primary infection, notice nothing more than slight frequency, dysuria and discharge, so slight that they pay little attention. *Indeed, 60-70 per cent of women from whom gonococci can be cultured from the lower genital tract are free from symptoms and obvious physical signs of the disease.* It is these who are responsible for the spread of infection and they can only be found and treated by an efficient system of 'contact tracing'. Routine mass screening using meticulous bacteriological techniques is, according to most reports, of little value. One study of 1000 pregnant women (selected as being at special risk because of symptoms or an irregular domestic background) revealed gonococci in only two; both of these had symptoms and signs which would have inevitably prompted investigation.

Even salpingitis can develop without producing an acute picture and in a subclinical degree is probably quite common.

No matter whether it has a dramatic or quiet onset, gonorrhoea persists as a chronic but contagious disease for many years. The organisms linger in the endocervix, Bartholin's glands, periurethral tubules and rectum but give rise to no symptoms or, at most, to a slight chronic mucopurulent vaginal discharge.

The most important and tragic sequel to gonorrhoea is tubal damage and closure which threaten future reproduction. Unlike the situation in the male, urethral stricture following gonococcal urethritis is almost unknown in the female. Disseminated gonococcal infection is a rare complication in less than 3 per cent of cases. These patients may also present with endocarditis and meningitis.

## Diagnosis

In the classical case, the diagnosis of gonorrhoea is usually suggested by the history of exposure, the acuteness of the onset of a purulent discharge, the associated urethritis, and the appearance of zones of congestion (*maculae*) around the orifices of Bartholin's ducts. In practice, it is the occurrence of urethritis in the patient's consort which often brings the woman to investigation, she herself having no symptoms.

Sixty per cent of women with proven gonorrhoea also suffer from *Trichomonas vaginalis* and/or *Chlamydia trachomatis*. *Candida albicans*, herpes simplex virus, etc. are also associated. So the disease should be suspected whenever there is a complaint of vaginal discharge.

The diagnosis can only be proved by the demonstration of gonococci in the genital tract secretions or in the lower rectum. In the female it is rare to find typical Gram-negative intracellular diplococci in direct smears of vaginal discharge, unless a very acute infection is present. The setting up of cultures is therefore mandatory and material for these is obtained from the endocervical canal. Cultures of the urethra, anal canal and pharynx are recommended (*see below*), but produce only a slight increase in the yield. When gonococcal septicaemia, pharyngitis or arthritis is suspected, it is necessary also to prepare cultures from the blood, throat swabs and synovial fluid. Gonococci will survive on ordinary swabs for approximately 2 hours. A longer interval than this between the collection of specimens and their arrival in the laboratory means the use of transport media such as Stuart's agar and crystal violet, or one of the proprietary preparations on the market. Alternatively, plates of warmed chocolate agar or of Thayer—Martin medium can be inoculated directly by the patient's bedside.

The woman should not have passed urine or used a douche before examination. Having wiped its orifice clean, the urethra is milked to obtain discharge from the paraurethral glands. Further material is obtained by milking Bartholin's glands and their ducts. Swabs are

next taken from the *endocervix* and finally from the *anal canal and rectum*. In proven cases of gonorrhoea, the organisms are found in Bartholin's ducts in 30 per cent, in the endocervix in 90 per cent and in the rectum in 50-60 per cent. The last two are therefore the most important sites to study and it is stated that a combination of their findings provides an almost 100 per cent accurate diagnostic test.

Nevertheless, negative findings, even when repeated, are never conclusive and it is impossible to be certain that a woman does not have gonorrhoea.

Similarly, tests of cure are unsatisfactory although negative bacteriological findings on three occasions are the accepted criteria. The best time to perform these is immediately after menstruation. Enzyme-linked immunosorbent assay (ELISA) tests have been developed which offer greater reliability.

Whenever gonorrhoea is diagnosed or suspected, it is essential to entertain the possibility of the patient having contracted syphilis at the same time. The case must therefore also be investigated from this stand-point and, meanwhile, no treatment given which might mask, without curing, this disease.

Antibiotic sensitivity of the organism is becoming important because of the resistant or less sensitive strains. The detection of penicillinase-producing strains of *N. gonorrhoeae* which are totally resistant to penicillin and relatively insensitive to several other antibiotics is important as these strains are spreading throughout the world.

## Treatment

If there is a severe systemic reaction, or if acute salpingitis is present, the patient should be put completely at rest in hospital and given intensive antibiotic therapy in divided doses. Otherwise she can remain ambulant but should be warned against coitus until pronounced cured. Except for the drainage of an abscess, local treatment should be avoided lest it encourage the spread of infection.

Penicillin used to be the remedy of choice in gonorrhoea. A single intramuscular injection of 4.8 mega units of procaine penicillin can be curative but the emergence of penicillinase-producing strains of *N. gonorrhoeae* led to the use of other agents. Further, some authorities felt that this dosage was inadequate in case of concomitant syphilis. Although, in general, this is very rare nowadays, there may be some settings where this is relevant.

Several of the newer quinolones, e.g. ciprofloxacin and ofloxacin have been used successfully as single-dose regimens, 500 mg and 400 mg, respectively. Quinolone-resistant strains have emerged in some Pacific and Asian countries, but CDC continues to recommend these in areas where there is no problem of resistance. However, quinolones should not be used in pregnant women.

Ceftriaxone is recommended by CDC for the treatment of uncomplicated gonorrhoea in a single, intramuscular injection of 125 mg. It cures rectal and pharyngeal gonorrhoea as well. Some patients allergic to beta-lactam antibiotics may show reaction. Ceftixime is a useful oral alternative. Spectinomycin, 4 g in a single intramuscular injection, is useful in treating anogenital gonorrhoea but does not treat pharyngeal gonorrhoea.

Because of the high incidence of associated chlamydial infections, therapy should be followed by azithromycin or doxycycline to treat this as well.

Sex partners should be treated, especially those exposed within two weeks prior to onset of symptoms or four weeks prior to diagnosis in an asymptomatic patient. Each authority and clinic tends to have its own favourite drugs and combinations of these; their choice is largely determined by knowledge of the drug sensitivities of the gonococci prevalent in the area.

Repeat cultures for test of cure are no longer recommended for all patients as cure rates of currently used regimes approach 90 per cent. They may be indicated if there is a doubt of patient compliance.

The treatment of gonococcal Bartholin abscess, salpingitis and infantile vulvovaginitis is described elsewhere.

### Chancroid (Soft sore)

Chancroid is becoming increasingly rare everywhere but is still an important STD in some areas in developing countries. It is much commoner in men than in women.

### Pathology and Clinical Features

The infection is caused by a Gram-negative streptobacillus — *Haemophilus ducreyi*. The disease appears 2-5 days after coitus and takes the form of multiple small papules or vesicles which quickly break down to leave acutely painful shallow ulcers which discharge offensive pus. These are usually multiple, but can be single, and are distributed on the labia majora and minora and sometimes within the introitus and around the anus.

Each ulcer is ringed with a bright red zone of congestion and surrounded by oedema. The ulcers bleed easily on gentle cleaning. Oedema is a striking physical sign.

The draining lymph nodes are usually unilateral and inguinal. They are painful and tender and become 'matted' together in a unilocular abscess — a distinguishing feature from syphilitic adenitis. Secondary infection is common and can produce much tissue destruction. Untreated, the inguinal abscess bursts onto the skin, forming a sinus. The infection does not spread and, although it can cause malaise and pyrexia, has no serious systemic effects.

### Diagnosis

The clinical features may be suggestive but the diagnosis can only be made by the demonstration of *H. ducreyi* in the discharge from the ulcers or in pus obtained by aspiration of an inguinal node or by polymerase chain reaction (PCR). Chancroid lesions can be confused with those of Behcet's syndrome, the type and sites of the genital ulcers being identical.

### Treatment

Experience is now so limited that it is difficult to judge the best antibacterial agent to use. *H. ducreyi* were initially susceptible to sulphonamides, trimethoprim, tetracycline, streptomycin and chloramphenicol. Presently, azithromycin (1 g orally single dose), erythromycin (500 mg 6-hourly for 7 days) or ceftriaxone (250 mg intramuscularly single dose) are the recommended drugs.

Along with antibiotics the patient is advised to rest during the acute stage of ulceration and her pain can be relieved with analgesics. If the inguinal nodes suppurate, the abscesses are aspirated. Healing usually occurs within two weeks.

## OTHER SEXUALLY TRANSMITTED INFECTIONS

Many other infections of the female genital tract can be acquired by intercourse with an infected partner but can also arise in other ways; in some cases the latter are the more important.

The following infections can, or possibly can, be transmitted during the close bodily contact involved in coitus. The first six are described in this section, the following four elsewhere; the last two are listed merely for completeness.

- HIV infection and AIDS
- Genital Human Papillomavirus (HPV)
- *Chlamydia trachomatis* infections
- Lymphogranuloma venereum
- Genital mycoplasmas
- Granuloma inguinale
- Genital herpes
- Trichomoniasis
- Vulvovaginal candidiasis
- Pediculosis pubis
- Genital molluscum contagiosum
- Genital scabies

Bearing in mind its relationship to the previous practice of coitus and infection with HPV, some would now include *carcinoma of the cervix* occurring in later life as a sexually transmitted disease.

Hepatitis B virus is a major cause of acute and chronic liver disease including primary liver cancer. The detection of the virus in saliva suggests that sexual transmission may be involved and there is good evidence for infection resulting from both heterosexual and homosexual contact. Direct transmission from the mother to the foetus or neonate is also of importance in areas where the carrier rate is high. The development of an effective vaccine offers hope of controlling the spread of the virus.

### Human Immunodeficiency Virus (HIV) Infection and Acquired Immune Deficiency Syndrome (AIDS)

AIDS is a disease of the immune system caused by a retrovirus, the Human Immunodeficiency Virus (HIV) that results in the development of either life-threatening opportunistic infections or the development of unusual malignant lesions or both. Although AIDS is classified as an infectious disease, its transmission requires sexual contact or direct entry of virus-infected blood or blood products into the circulation. There is little evidence that AIDS is transmitted by any non-sexual form of person-to-person contact.

The first recognised cases of AIDS occurred in male homosexuals and such individuals constitute the main risk group (about three-quarters of reported cases occur in homosexual or 'bisexual' males). Drug users who share infected needles constitute another high-risk group. AIDS has been diagnosed in female sexual partners of affected males and this is the predominant mode of transmission today, although this has always been the case in Africa. Vertical transmission occurs from mother

to foetus. In Asia, the infection is now moving into the low-risk general population and is likely to move from the urban to the rural areas. Occupational transmission of HIV from patients to health care and laboratory workers is a small but definite risk. While the converse is theoretically possible, it is very rare.

HIV has been isolated from the blood, semen and saliva of affected individuals. Some individuals who have been exposed to, or are infected by, the virus do not show any evidence of such disease. This suggests either a long incubation period or the operation of other factors during the incubation period which, together with the HIV, precipitate the loss of cell-mediated immunity. It is estimated that 36 million people are infected with HIV, with approximately two-thirds in Africa and one-fourth in Asia. Explosive patterns of the disease are being seen in India and Thailand. In the twenty-first century, it is expected that the magnitude of the epidemic in these regions will exceed that in sub-Saharan Africa.

### Pathology

The human immunodeficiency viruses, HIV-1 and HIV-2 belong to the family of human retroviruses and the subfamily of lentiviruses. HIV-1 is the commonest cause of HIV disease throughout the world but different subtypes are prevalent in different areas. HIV-2 was originally seen in West Africa but has now been identified in Europe and America as well.

HIV infection results in a progressive decline in the number and function of helper T lymphocytes, e.g. the CD4 cells and monocytes. This results in the development of a profound immunodeficiency state with clinical manifestations in virtually all systems of the body.

CD4 counts greater than 800 cells/mm<sup>3</sup> are considered normal. In the early stage of disease the count is >500 cells mm<sup>3</sup>, in the intermediate stage 200-500 cells mm<sup>3</sup>. HIV-positive patients in the advanced stage with CD4 counts less than 200 cells/mm<sup>3</sup> are defined as having AIDS regardless of the presence of symptoms or opportunistic infection. The duration of time from initial infection to AIDS can vary from 3 years to several decades, the median time being 10 years.

### Clinical Features

About 30-70 per cent of patients who contract HIV infection develop an acute illness after an incubation period of 7-10 days. The symptoms are non-specific, i.e.

fatigue, fever, sore throat, weight loss and myalgia. Some patients may develop cervical lymphadenopathy, a diffuse skin rash or ulcerations of the mouth or genitalia. The diagnosis is usually not made at this stage, but may be retrospectively diagnosed later in the course of the illness.

In the stage of clinical latency, patients may remain entirely asymptomatic. As CD4 counts decline, the appearance of an opportunistic infection may be the first manifestation of HIV disease. Persistent generalised lymphadenopathy is also a feature of early symptomatic disease.

Oral manifestations develop in almost all patients at some point in the course of their disease depending on the type, frequency and severity of disease. Various manifestations seen in the early stage include oral hairy leukoplakia, candidiasis, HSV infection, aphthous ulcers and gingivitis. Impaired skin immunity leads to cutaneous manifestations: molluscum contagiosum, herpes zoster, HSV infection, seborrhoeic dermatitis, scabies and folliculitis. Thrombocytopenia manifests as bleeding gums, petechiae and easy bruisability. Peripheral neuropathy can occur at all stages of the disease. Aseptic meningitis occurs in all but the very late stages. Later in the course of the disease, HIV-infected individuals present with oesophagitis, diarrhoea, malabsorption and weight loss. There is a ten-fold increase in the incidence of pneumonia. *Pneumocystis carinii* pneumonia (PCP) is pathognomonic of AIDS and is generally seen when CD4 counts are less than 200 cells/mm<sup>3</sup>. Similarly, tuberculosis is also generally seen with CD4 counts of less than 200 cells/mm<sup>3</sup>. While pulmonary tuberculosis in early stage HIV has a presentation similar to that in non-HIV patients, AIDS patients have an atypical presentation characterised by diffuse pulmonary infiltrates.

Other secondary infections include infection with *Toxoplasma gondii*, *Cryptosporidia*, *Cryptococcus*, *Cytomegalovirus*, *Treponema pallidum*, *Histoplasma* and *Bartonella*. Kaposi's sarcoma is another presentation virtually pathognomonic of AIDS.

Ocular manifestations are seen, the most serious being cytomegalovirus retinitis. Endocrine disorders in these patients may be consequent to general debility. These include adrenal insufficiency and hypogonadism. HIV-associated nephropathy, myocarditis or dilated cardiomyopathy have also been described. Infection of the central nervous system results in an AIDS-dementia

complex in the majority of patients late in the course of the illness. Seizures occur frequently and may be caused by neoplasms, opportunistic infections or HIV encephalopathy.

Mother-to-infant transmission occurs in about 25 per cent of cases. The risk is increased in advanced stages of the disease and higher levels of viral replication, and can be reduced by zidovudine therapy (*see below*).

The presence of vulvovaginal candidiasis which is persistent, recurrent or responding poorly to therapy; moderate or severe cervical dysplasia; carcinoma cervix *in situ* or pelvic inflammatory disease, especially if complicated by a tubo-ovarian abscess in an HIV-infected individual places the case in category B, i.e. these are attributed to HIV infection or it is considered that their clinical course or management are complicated thereby. The presence of invasive cervical cancer in an HIV-infected individual places the case in Category C, i.e. it is now listed in the AIDS surveillance case definition. The incidence of abnormal Papanicolaou smears of the cervix is about 60 per 1000 in women with HIV infection while it is approximately 5 per 1000 in otherwise healthy women.

### Diagnosis

The diagnosis of HIV infection requires the demonstration of antibodies to HIV or its direct detection. ELISA is the standard screening test which detects antibodies against HIV-1 and HIV-2 with a sensitivity of over 99.5 per cent. Antibodies can be detected 4 to 12 weeks after infection. However, false-positive results may occur due to auto-antibodies, hepatic disease, recent influenza vaccination and have also been reported in women taking oral contraceptives. Therefore, if ELISA is positive or indeterminate, the Western blot test is done and is considered positive if it contains bands to at least two of the following gene products: p24 gp41 and gp 120/160. If the Western blot test is indeterminate it is repeated after one month.

A PCR test can also be done and is the most specific. DNA and RNA PCR are both possible. The high cost of PCR and the problem of false-positive results due to contamination have resulted in its being used only when standard serologic tests fail to provide a definite answer.

HIV-1 disease markers like CD4 cell count and plasma HIV-1 RNA levels are important indicators of disease stage and are used in laboratory monitoring of patients. β<sub>2</sub>-microglobulin and neopterin levels correlate



with disease progression and are predictive of progression to AIDS independent of the CD4 count.

### Treatment

Counselling of the patient regarding the natural history of the disease, transmission, nature and goals of therapy should be done in all cases. Support systems with qualified personnel are essential.

Antiretroviral therapy is the cornerstone of treatment. Zidovudine (ZDV) was the first drug used. It is a nucleoside analogue which functions as a reverse transcriptase inhibitor. Its major side-effect is bone marrow suppression. Proximal myopathy is also commonly seen. Emergence of strains which are resistant to ZDV has limited its use as long-term monotherapy.

Several other antiretroviral agents have now been identified. Combination therapy is generally preferred. The best regimen still has to be worked out. Zidovudine and didanosine have been the mainstay of therapy but other regimes with zalcitabine and lamivudine have been tried. Protease inhibitors in use include saquinavir, zidovudine, indinavir and nelfinavir. Combinations of protease inhibitors with reverse transcriptase inhibitors, or of various protease inhibitors, or of nucleosides with non-nucleosides have all been tried.

Prophylactic therapy is started in asymptomatic patients if the CD4 cell counts are less than 500 cells/mm<sup>3</sup>; or even if CD4 counts are >500 cells/mm<sup>3</sup>, if HIV-1 RNA titres are greater than 10000-20000 copies/ml or CD4 counts are decreasing at a rate greater than 10 cells per month. It helps to maintain the CD4 count, prolongs disease-free interval and inhibits viral antigen levels in the blood. It also decreases the severity of complications like the AIDS-dementia complex. Once started, it is continued for life.

Prophylaxis for *Pneumocystis carinii* pneumonia is started if the CD4 count is less than 200 cells/mm<sup>3</sup>. If the patient develops fresh symptoms of AIDS, therapy must be started regardless of CD4 counts.

In pregnancy, ZDV therapy is started in the second or third trimester. Intravenous ZDV administration during labour and therapy for the infant substantially decreases the risk of vertical transmission.

The management of opportunistic infections is a very important aspect of care of the AIDS patient. Treatment regimes for all opportunistic infections have been clearly defined.

Prevention of HIV infection requires education of all adolescents and adults regarding the method of spread of disease, safe sexual practices, use of disposables and testing of blood products.

Regular use of condoms can prevent HIV infection in a large number of cases. The addition of nonoxynol-9 improves the protection as it is toxic to HIV. It also improves the contraceptive efficacy.

Partners of HIV-positive patients must be instructed in the use of condom protection even if they are using other contraceptive methods.

Physicians and surgeons must observe universal precautions at all times as 90 per cent of HIV-infected individuals are asymptomatic.

Postexposure prophylaxis with ZDV 200 mg thrice daily for 4 weeks has been recommended by CDC in the case of percutaneous exposure to blood infected with HIV. Lamivudine, indinavir and saquinavir are also used.

### Genital Human Papillomavirus (HPV)

Papillomaviruses are a group of small DNA viruses that produce epithelial cell proliferation (papillomas). More than 30 HPV types infect the genital tract. These have been grouped into high- and low-risk types, based on the malignant potential.

#### *Pathology and Clinical Features*

HPVs are epitheliotropic and their replication depends on the presence of differentiating squamous epithelium. HPV-infected epithelium characteristically has a hyperplastic prickle cell layer (acanthosis). The stratum corneum consists of 1-2 layers of parakeratosis. There are deep dermal papillae and a sharp border with the dermis. Koilocytes have been considered a marker for HPV infection. They are mature squamous cells with a large, clear perinuclear zone. The nuclei are enlarged and hyperchromatic; double nuclei may be present. Koilocytes may be scattered throughout the outer cell layers. Koilocytic changes may, however, be mimicked by other cellular changes or may be subtle.

HPV infection is commonest in young, sexually active women, and is seen in 20-25 per cent of women in the third decade. Not all of these women will become symptomatic. Very often the infection disappears spontaneously after 1 to 2 years. Women over the age of

30 years with persistent HPV infection are most likely to manifest disease.

Two major manifestations of genital HPV are: genital warts which can be seen by the naked eye (usually caused by type 6 or 11) and squamous intraepithelial lesions (SILs) of the cervix that are detected by cytology and colposcopy (usually caused by type 16 or 18). Although SILs are seen in the vulva, vagina and penis also, the clinical significance of these is unclear. The clinical diagnosis and management of SIL and of cancer cervix is discussed elsewhere.

The four morphological types of genital warts are condylomata acuminata, which have a cauliflower appearance; papular warts, which are flesh-coloured, dome-shaped, 1-4 mm in diameter; keratotic warts, which have a thick, crusty layer, resembling common skin warts; and flat-topped macular warts. Generally, condylomata occur on moist, partially keratinised epithelium, keratotic and papular warts on fully keratinised epithelium, and macular warts on either partially or fully keratinised epithelium.

The diagnosis and management of warty lesions is discussed elsewhere.

### *Chlamydia Trachomatis Infections*

*Chlamydia trachomatis* is being increasingly recognised as the pathogen responsible for a variety of conditions, many of which resemble gonococcal infections. However, many chlamydial infections produce few or no symptoms in women and escape detection. Moreover, lack of adequate laboratory facilities for testing has led to the high prevalence of these infections in several parts of the world.

Prevalence ranges from 3-5 per cent in asymptomatic women to over 20 per cent in those attending STD clinics. In industrialised countries this is now recognised as the commonest cause of pelvic inflammatory disease (PID).

### Pathology

*Chlamydia trachomatis* is one of four species within the genus *Chlamydia*. The chlamydiae have a unique growth cycle. They are obligate intracellular parasites and cannot be cultivated on artificial media because they depend on their host for ATP and nutrient supplies. They survive by a replicative cycle that results in death of the infected host cells. Thus they can never be part of the normal flora of the genital tract and are always pathogenic when present.

Virtually all chlamydial infections are sexually transmitted. Infants may acquire the infection by passage through an infected birth canal and develop ophthalmia neonatorum.

Many serotypes have been identified based on an immunofluorescent antibody typing system of which L1, L2 and L3 are associated with lymphogranuloma venereum and D, E, F, G, H, I, J and K have been associated with non-gonococcal urethritis, cervicitis, salpingitis, proctitis, epididymitis, inclusion conjunctivitis and pneumonia of newborns. Extensive subepithelial inflammation, epithelial ulceration and scarring are the end result.

### Clinical Features

Infections caused by *C. trachomatis* are very similar to those caused by *N. gonorrhoeae* in terms of the pattern of infection and sequelae (*see above*). However, chlamydial infections are more insidious in onset and generally produce very mild or no symptoms at all.

Patients may present with mucopurulent discharge from the endocervical canal and hypertrophic ectopy of the cervix which bleeds on touch. On colposcopy they may be seen to have immature squamous metaplasia. Dysuria and frequency of micturition with bacteriuria  $< 10^5$  organisms/ml of urine is pathognomonic of chlamydial infection in young, sexually active women. Clinical evidence of Bartholinitis may be due to chlamydial infection alone or in combination with gonococcal infection. Menorrhagia and metrorrhagia, often seen in association with salpingitis, may be the manifestations of concomitant endometritis. 'Silent' salpingitis is the hallmark of chlamydial infection which results in tubal scarring and infertility or ectopic pregnancies.

The Fitz-Hugh-Curtis syndrome of perihepatitis with salpingitis, long considered a complication of gonococcal infection, has now been recognised as being commoner with chlamydial infection. Patients present with right upper quadrant abdominal pain, fever, nausea or vomiting. While salpingitis may not be diagnosed clinically, laparoscopy shows extensive tubal scarring, adhesions and inflammation. Periappendicitis may also occur.

Among men, it is estimated that 35-50 per cent of cases of non-gonococcal urethritis are caused by *C. trachomatis*. Reiter's syndrome has also been linked to *C. trachomatis*. This is a combination of non-specific

urethritis, polyarthritis and conjunctivitis, sometimes with uveitis and skin lesions. The sexually transmitted variety is almost always confined to young adult men.

### Diagnosis

The first cultures of *C. trachomatis* were done on hen's egg yolk sacs. Cell culture plates are expensive, hence non-culture diagnostic tests which detect the antigen are used which are equally reliable e.g. direct fluorescent antibody (DFA) and ELISA. Samples are taken with cotton-tipped swabs which after mopping should pick up columnar epithelial cells from the exudate. DFA is the reference standard; ELISA can be done in larger numbers than DFA but is less reliable. PCR is used in developed countries even as a screening modality, but widespread use of these methods is still not available in developing countries.

### Treatment

Tetracyclines administered in a dose of 500 mg 6-hourly for 7 days eradicates *C. trachomatis*. Erythro-mycin 500 mg 6-hourly for 7-14 days, ofloxacin 200 mg twice daily for 7-14 days, doxycycline 100 mg twice daily for 10 days or azithromycin 1 g as a single dose are all effective in uncomplicated chlamydial infection. In pregnancy, erythromycin or amoxicillin can be used but a test of cure is recommended two weeks after therapy because of the lower efficacy in pregnancy.

### Lymphogranuloma Venereum (LGV)

This disease is mostly seen in tropical countries. Elsewhere it is rare but is sometimes found in immigrants and in prostitutes in sea ports where it is introduced by sailors. It occurs most commonly among the African races, notably those in the West Indies and in India, and parts of South-East Asia and South America. It more often affects men than women and personal uncleanliness appears to be a predisposing factor. It is usually, but not always, contracted by sexual intercourse. It is caused by *Chlamydia trachomatis* serotypes L1, L2 and L3.

### Clinical Features

The incubation period is 7-14 days. The initial lesion is a painless papule, pustule or ulcer on the vulva and may quickly disappear. The infection persists in the

lymphatics, and spreads (mainly by lymphatics) to involve not only the tissues of the vulva but also those around and within the vagina and anus. Between 3 and 4 weeks the inguinal lymph nodes are involved. These painful swellings may be the first sign of the disease. The double genitocrural fold is a sign typical of LGV which is seen in approximately 20 per cent of cases, caused by the formation of a groove between groups of inflamed inguinal lymph nodes. The nodes tend to undergo necrosis and to form abscesses which release an offensive discharge, leaving chronic deep sinuses and much surrounding fibrosis. If the ulceration of the vulva and perianal region is extensive, it also heals with scarring and contracture. Fenestration of the nymphae is a characteristic end result. Chronic lymphatic obstruction and induration can result in vulvar elephantiasis and makes the vaginal walls feel rigid or rubbery in consistency (Fig. 19.6). Destruction or stricture of the urethra can occur. Rectal strictures and fistulas are not uncommon and can give rise to erroneous diagnoses of malignant disease. When the rectum is involved, there is diarrhoea and the passage of blood and pus *per anum*. Constitutional upset and pyrexia accompany the active stages of the disease.



**Fig. 19.6:** False elephantiasis resulting from healed lymphogranuloma venereum. There are also residual scars on the perineum and around the anus. The patient concerned gave a history of ulceration which persisted for 2 years

## Diagnosis

This is suggested by the clinical features and by laboratory findings. The *Frei test* is no longer used.

The diagnosis can be made by isolating the organism if facilities for culturing *Chlamydia* are available. The organism may be obtained either from a smear of material from lesions or from a lymph node abscess. Antibody against lymphogranuloma venereum serotypes can be detected by a microimmuno-fluorescent technique. A test for anti-*Chlamydia* antibody is available: the LGV complement fixation test. If the antibody titre exceeds 1 in 32, it is most likely to be due to lymphogranuloma venereum rather than other chlamydial infections. PCR may be used to demonstrate *Chlamydia* in infected secretions or tissues.

## Treatment

The treatment of choice is to give one of the tetracyclines in a dose of 500 mg 6-hourly or doxycycline 100 mg bd for 21 days, and to aspirate the inguinal abscess repeatedly. Incision and drainage is contraindicated. If the response is unsatisfactory the tetracyclines are repeated after an interval of several days. Alternatively, chloramphenicol, erythromycin, minocycline or rifampicin can be used.

The end results of tissue destruction and fibrosis sometimes require reconstructive surgery on the vulva, urethra and vagina.

### Genital Mycoplasmas

*Mycoplasma hominis* and *Ureaplasma urealyticum* are the most common mycoplasmas to be isolated from the genital tract. They can be acquired during passage through the birth canal or later, after puberty, usually as a result of sexual contact.

## Pathology and Clinical Features

*Mycoplasma* belong to the class 'Mollicutes' and have developed from anaerobic bacteria by the process of gene deletion. Of the 16 mycoplasmas detected in human beings, six are known to inhabit primarily the genitourinary tract. Some of these may be found in the oropharynx because of orogenital contact.

Genital mycoplasmas have been implicated in a wide variety of clinical conditions. They were initially implicated in the aetiology of non-gonococcal urethritis

but this has not been supported. *Ureaplasma urealyticum* appears to play an important role in the aetiology of *Chlamydia-negative* non-gonococcal urethritis, though the severity of inflammatory response diminishes with repeated inoculations.

*M. hominis* may have a role in pelvic inflammatory diseases; here ureaplasmas do not seem to have any significance. *M. genitalium* has not been shown to be involved in bacterial vaginosis (BV) but the role of mycoplasmas in BV needs further understanding. *M. hominis* can produce postabortal and postpartum fever. Ureaplasmas may also be causative in post-partum pyrexia.

The genital mycoplasmas have a more important impact on disorders of reproduction. Treatment of ureaplasma infection has been shown to improve sperm motility and quantity in patients with infertility although the conception rates have not been shown to increase. Most importantly, a significant association has been shown between mycoplasmal infection and recurrent spontaneous abortion, preterm delivery, preterm premature rupture of membranes and chorioamnionitis. *Ureaplasma* infection has been associated with low-birth-weight infants.

## Diagnosis

Specialised media have been used to culture *M. hominis* but several mycoplasmas are fastidious and difficult to culture. Non-culture procedures are important in this latter group. Serological tests have been popular in this regard.

## Treatment

Tetracyclines are the drugs of first choice. With the emergence of resistant *M. hominis* strains, clindamycin has become the next alternative. Azithromycin is sometimes used to treat non-gonococcal urethritis but some ureaplasmas may be resistant to it. In these cases, erythromycin or sparfloxacin may be used.

In persistent or recurrent urethritis, prolonged treatment for more than a month with a tetracycline or a macrolide may be required.

## Granuloma Inguinale (Donovanosis)

Donovanosis was first described from India and is now mostly seen in some developing countries. Whilst there is much confusion between this disease and the rather

more common lymphogranuloma venereum, the regional lymph nodes are not involved in the early stages of this disease.

### Pathology

The infecting organism is a Gram-negative bacillus, *Calymmatobacterium granulomatis*, with large capsules which can be seen within mononuclear cells when stained by the Giemsa method. The disease usually manifests itself 10-50 days after coitus with an infected partner. The initial lesion is nearly always on the vulva and presents as a papule which breaks down to form a chronic red ulcer with rolled edges, features which simulate those of cancer or a chancre. The ulcer spreads directly, rather than by lymphatics, to involve the whole vulva, and sometimes the vagina, cervix, anus and the skin of the groins (the esthiomene stage). The condition is not particularly painful and ultimately heals to leave fibrosis, distortion of the tissues, and false elephantiasis or hypertrophy of the vulva. Sections of affected tissues often disclose epithelial unrest. Indeed, cancer can supervene. In pregnancy, the disease has a more aggressive course.

In the active stage of the disease the inguinal nodes are enlarged but do not suppurate; this is a distinguishing feature from lymphogranuloma venereum.

### Diagnosis

The diagnosis of granuloma inguinale is proved by finding *Donovan bodies* within mononuclear cells in material obtained from the ulcer. These are encapsulated diplobacilli which show up with Giemsa and Leishman stains. It is common not to find these bodies and this leaves the diagnosis in doubt. No serologic tests are currently in use. However, the clinical picture is characteristic.

### Treatment

This infection does not respond well to any treatment. Streptomycin and co-trimoxazole have been used in India and found to be effective for large lesions. The quinolones and high-dose ceftriaxone are also effective. Resistance is reported with tetracyclines. Azithromycin 500 mg daily for one week may emerge as the most cost-effective therapy. In pregnancy, erythromycin is the drug of choice.

The end results of the destructive process may ultimately require plastic surgery or excision of the vulva in whole or in part.

## GENITAL TUBERCULOSIS

### Aetiology

Tuberculosis of the female genital tract is common amongst all communities where pulmonary or other forms of extragenital tuberculosis are prevalent, and this despite early recognition and effective treatment of such lesions. Those who take a contrary view do not conduct a proper search for it sufficiently often. It follows that genital tuberculosis is nearly always secondary to a focus elsewhere in the body but the spread takes place at a very early stage of the disease - usually in adolescence or early maturity. Thus, by the time the genital lesion is found, which can be at any age, the primary has often healed and is inconspicuous. Nevertheless, 50 per cent of affected women give a past history of an extragenital infection, and a further number can recall, if questioned closely, contact with the disease in childhood or adolescence. The tubercle bacilli reach the genital tract by one of the following mechanisms.

#### *Bloodstream*

This mechanism accounts for at least 90 per cent of cases, the primary focus being most often situated in the lungs, lymph nodes, urinary tract, bones and joints - in that order.

#### *Descending*

In this type the infection reaches the pelvic organs by direct or lymphatic spread from infected adjacent organs such as the peritoneum, bowel and mesenteric nodes.

#### *Ascending*

There is a theoretical possibility that a few cases of tuberculosis of the vulva and vagina, and of primary tuberculosis of the cervix, are explained by children sitting unclothed where others have spat or coughed, and in adults having coitus with a male suffering from urogenital tuberculosis.

### Pathology and Bacteriology

When the pelvic disease is secondary to tuberculous peritonitis, or when the primary focus is in the lymph

nodes or bowel, the bovine bacillus (*Mycobacterium tuberculosis bovis*) is likely to be involved. In all other cases it is generally the human bacillus (*M. tuberculosis*) which is found. So, in those countries where cattle or their milk are relatively free from the tubercle bacilli, the human bacillus is found in 95 per cent of cases of genital tract infection.

Any part of the genital tract can be affected but the common sites are the fallopian tubes and the endometrium. The tubes are involved in at least 90 per cent of cases and, following bloodstream spread, the genital disease probably starts there. It begins in the submucosa at their outer ends and gradually progresses inwards, bombarding the endometrium with bacilli. The finding of endometrial tuberculosis almost always means that the tubes are infected, but tuberculous salpingitis can exist without associated endometritis.

The genital infection can be an acute and rapidly extending disease but is mostly indolent. There are several cases reported in which the disease appeared to commence, or to become violently active, immediately after pregnancy. In such circumstances fatal miliary spread is not uncommon.

#### *Vulva and Vagina*

Tuberculosis of the vulva and vagina usually takes the form of shallow, superficial, indolent ulcers with undermined edges. The ulceration tends to spread slowly, healing in some areas with the formation of scar tissue. A vulvar hypertrophic lesion is less common and mostly represents inflammatory induration and oedema resulting from fibrosis and lymphatic obstruction.

#### *Cervix*

Clinically recognisable tuberculosis of the cervix can be ulcerative but more often appears as a bright red papillary erosion which bleeds easily. It can be confused with carcinoma. As a histological finding, cervical tuberculosis is not uncommon in cases of endometrial tuberculosis.

#### *Uterus*

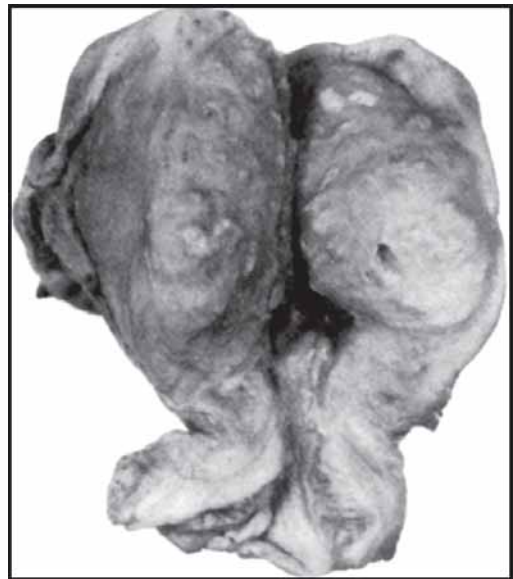
The uterus usually looks normal to the naked eye although a typical tuberculous ulcer may rarely be seen in the endometrium. Extensive involvement can result in collections of caseous material to form a type of pyometra, or to cause abscesses in the myometrium (Fig.

19.7). Adhesions and partial obliteration of the cavity are also described. Ordinarily, however, tuberculous endometritis is only recognised by histological and bacteriological examination of the tissues (*see below*).

#### *Fallopian Tubes*

The appearance of tuberculous tubes varies widely and depends to some extent on whether the infection is blood-borne or spreads directly from the peritoneum or bowel. In the one case the disease is primarily an endosalpingitis, in the other an exosalpingitis with the possibilities of tubercles on the surface and of dense surrounding adhesions.

Sometimes the tubes look completely normal; more often they appear red, oedematous and swollen when the infection is active, and fibrosed when it is chronic. They do not always have tubercles on their surface. 'Tubercles' when seen on tubes and the peritoneum at laparoscopy or laparotomy are not always caused by tuberculosis. They may be an end-result of any chronic inflammation, whether infectious or non-infectious, e.g. talc or starch granulomas, or peritoneal deciduosis. The tubal lumina are closed in only 50 per cent of cases in which there is bacteriological and histological evidence of endometrial disease. In this respect, however, it seems likely that many examples of tubal obstruction of



**Fig. 19.7:** Multiple tuberculous abscesses in a chronically thickened myometrium. This is a rare manifestation of tuberculosis and the appearance of the lesion might be mistaken for that of adenomyosis

uncertain aetiology represent completely inactivated, and unprovable, old tuberculous lesions. In tuberculosis the obstructions are typically multiple and the tube wall is thickened and shotty. Sometimes a localised closure at the outer end results in the formation of a hydrosalpinx or a pyosalpinx with thick fibrous walls which can become calcified or even ossified (Figs 19.8 and 19.9). A tuberculous pyosalpinx is often remarkably free from adhesions and may be so large that the patient's

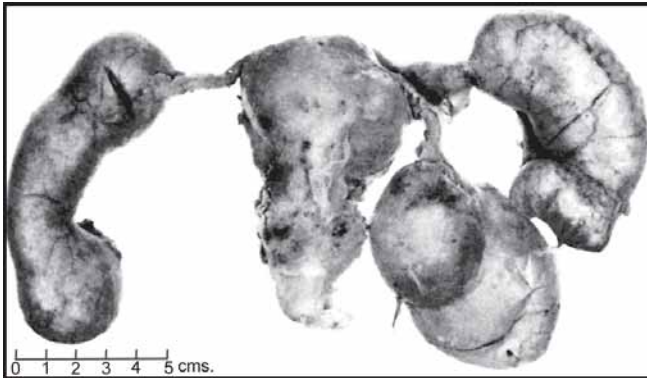
complaint is the presence of an abdominal tumour (Figs 19.8 and 19.10).

A hypertrophic form of endosalpingitis has the macroscopic and sometimes microscopic appearances of adenocarcinoma and can be mistaken for such.

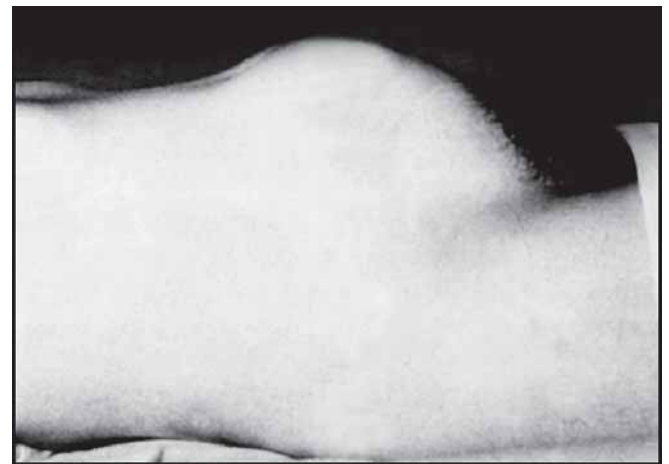
Secondary infection is often present and may itself account for symptoms or for exacerbations of the disease.

### Ovaries

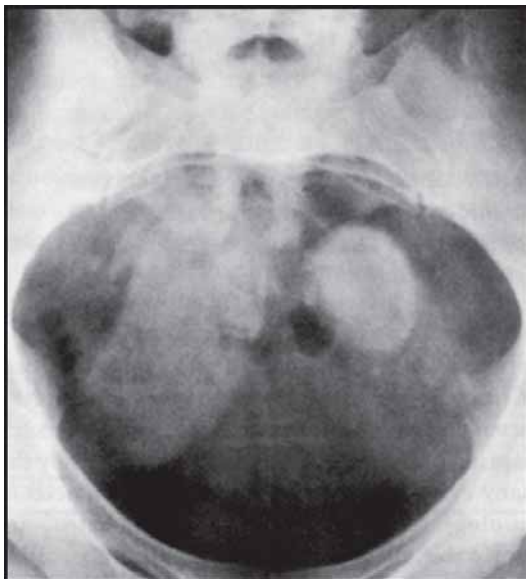
The ovaries are infected in at least 30 per cent of cases of tuberculous salpingitis but ovarian tuberculosis without tubal involvement is rare. The disease can manifest by way of surface tubercles, adhesions and thickening of the capsule, retention cysts, and sometimes by caseating abscess cavities in the substance of the ovary (Fig. 19.11). Often, however, the ovaries have a normal macroscopic appearance and the diagnosis is only revealed by laboratory studies of excised tissue.



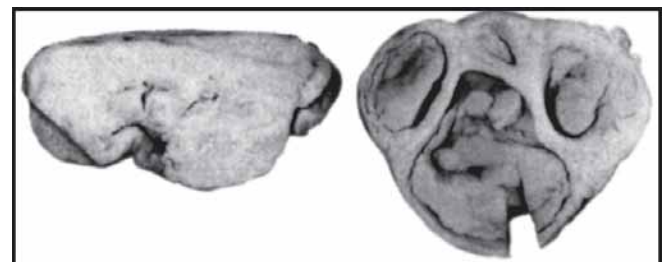
**Fig. 19.8:** Tuberculous pyosalpinges relatively free from adhesions, as they commonly are. There is also a small cyst in the right ovary. This specimen was removed from a nulliparous woman aged 40 years whose only complaint was the presence of a lower abdominal tumour



**Fig. 19.10:** Tuberculous pyosalpinges causing an abdominal tumour arising from the pelvis and extending to the umbilicus. (By courtesy of the Editor of *J Obstet Gynaecol Br Commonw*)



**Fig. 19.9:** Direct radiograph of the lower abdomen and pelvis before operation in the case illustrated in Fig. 19.8. The pyosalpinges are visible because of slight calcification in their walls. This appearance permitted a preoperative diagnosis of tuberculosis



**Fig. 19.11:** Tuberculosis of the ovaries. There are typical multiple caseating abscesses in one, and diffuse fibrosis and enlargement of the other

### *Fistulas and Sinuses*

Tuberculous fistulas and sinuses involving the abdominal wall, tubes, uterus, vagina, bladder and bowel can arise spontaneously (Figs 19.12A and B), but are mostly the result of inadequate or injudicious surgery.

### Clinical Features

#### *Tuberculosis of the Vulva and Vagina*

Vulvar lesions are usually painful and tender; vaginal ulcers, unless sited at the introitus, are painless. Both often cause a bloodstained purulent discharge.

#### *Overt tuberculosis of the Cervix*

This is painless but causes the same type of discharge and also postcoital bleeding. A cauliflower growth which closely mimics malignancy is often seen.

#### *Tuberculosis of the Uterus and Adnexa*

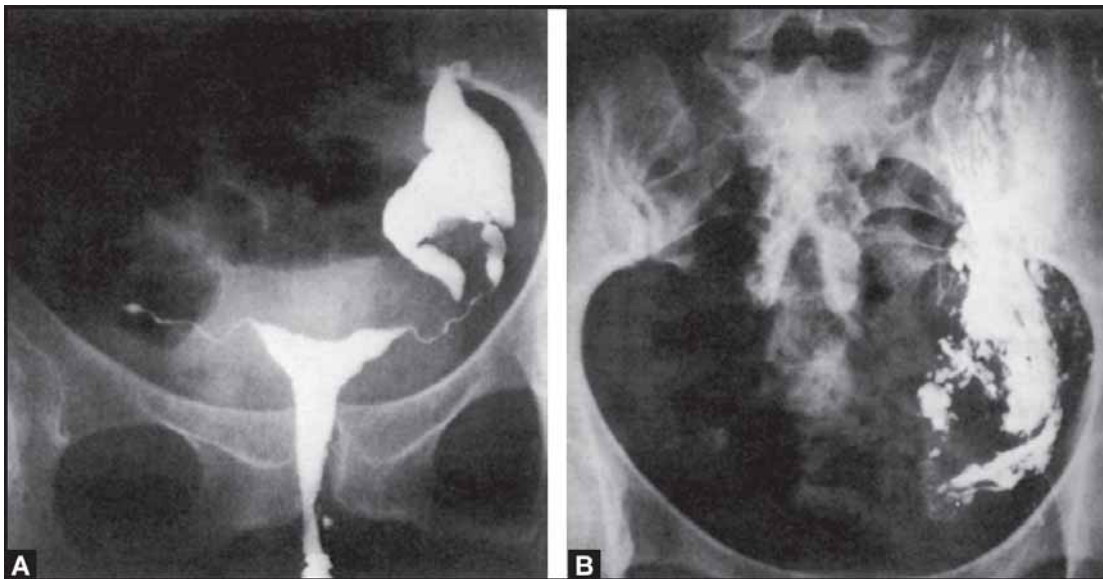
This is often a silent disease. It may be present for 20 or more years without producing any symptoms, the woman remaining in apparently excellent health. The

pelvic organs also feel normal on bimanual examination in 50 per cent of proven cases.

The presence of pelvic tuberculosis is most often revealed by the investigation of childlessness and therefore is usually discovered in women aged 20-40 years. In developed countries, tuberculous infection of the uterus and tubes is now demonstrable in less than one per cent of all cases of infertility studied, varying with the prevalence of pulmonary tuberculosis in any community 15-20 years previously.

The frequency with which it is found in both symptomless and complaining women, however, depends on the care taken to look for it. Moreover, the symptoms credited to it, and their statistical importance, depend on the types of cases in which tests for tuberculosis are made. Thus, if the search is limited to all women complaining of infertility, one picture of associated symptomatology appears; if it is extended to all women complaining of amenorrhoea or to women with menorrhagia or postmenopausal bleeding, different pictures emerge.

It should be routine practice to look for bacteriological and histological evidence of endometrial tuberculosis in



**Figs 19.12A and B:** A tuboretroperitoneal fistula resulting from tuberculous salpingitis. A woman aged 27 years complained of infertility and was first subjected to tubal insufflation and curettage. The insufflation was positive (misleadingly so as was subsequently shown) and the endometrium was histologically and bacteriologically negative for tuberculosis, (A) A salpingogram showing the right tube closed at its outer end. From the distal end of the left tube, which is dilated, there is a small track through which the medium passed, (B) A straight radiograph taken 24 hours later shows that the medium escaped not into the peritoneal cavity but extraperitoneally. Laparotomy confirmed that the outer end of the left tube communicated by way of a caseating abscess with the extraperitoneal tissues on the side wall of the pelvis



*all* cases of infertility and of amenorrhoea, and otherwise only when there are grounds for clinical suspicion. The special symptoms are as follows.

#### *Infertility*

Although 10 per cent of women with proven endometrial infection have had babies or abortions, the commonest symptom of pelvic tuberculosis is primary infertility. This is a feature of 70 per cent of cases and occurs even though the fallopian tubes are open. It then reflects abnormal tubal and endometrial function.

#### *Ectopic Pregnancy*

Every woman who has, or has had, a tubal pregnancy should also be suspected of having tubal tuberculosis, active or healed, apart from the more obvious causes nowadays, including chlamydial infection. Indeed, tubes removed for this condition should still be examined bacteriologically from this standpoint.

#### *Menstrual Disturbance*

In approximately 50 per cent of cases the menstrual function is normal. In the others it is generally held that the change is mostly in the direction of menorrhagia and polymenorrhoea. In my experience, however, and unlike other infections, tuberculosis more often causes amenorrhoea or oligomenorrhoea. This is sometimes explained by suppression of ovarian function; in such cases, compensatory overactivity of the anterior pituitary can result in a raised excretion of gonadotrophins. In other cases, however, there is evidence that ovulation continues; the amenorrhoea is then attributable to the endometrial damage.

Menopausal and postmenopausal bleeding can have endometrial tuberculosis as a basis. Dysmenorrhoea rarely, if ever, occurs.

#### *Intermenstrual Discharge*

This can be bloodstained if there is ulceration of either the cervix or endometrium.

#### *Pain*

An intermittent chronic ache in the lower abdomen, often of long standing, is noted in 20-30 per cent of cases. Indeed, 20 per cent of sufferers from pelvic tuberculosis have previously had a normal appendix removed.

Unusual activity of the infection occasionally causes symptoms and signs of acute or subacute peritonitis. Exacerbations of this kind are sometimes precipitated by tubal patency tests.

#### *General Disturbances*

Conditions such as malaise, loss of weight, night sweats and pyrexia are only seen during an unusually active phase of the disease.

### Diagnosis

The clue to the diagnosis of pelvic tuberculosis is to have the condition in mind; although the incidence of tuberculosis is falling in many countries, immigration may bring problems. The only difficulty arises over those cases, and there must be many, where infection in adolescence has become quiescent leaving no active organisms, merely residual damage and clinical suspicion. Some of the guidelines are as follows.

Tuberculosis should be suspected and excluded in every woman whose infertility or amenorrhoea is not explained by other causes. Any *virgin* having symptoms and signs of chronic pelvic infection should be assumed to have tuberculosis until it is proved to the contrary. Any pelvic infection which is slow to respond to the ordinary methods of treatment is suspect, and so is one which shows an exacerbation after curettage or tubal patency tests, or one which is not accompanied by polymorphonuclear leucocytosis. Sometimes a previous history of peritonitis, appendicectomy with slow healing, pleurisy, and a prolonged illness in childhood, or a history of tuberculosis affecting other members of the family and childhood contacts, provides the lead.

The finding of an active or healed extragenital lesion should always raise suspicions, as should the radiological demonstration of calcification in the tube or ovary or the classical appearance of *isthmica nodosa* on a hysterosalpingogram performed before the diagnosis is suspected or made.

If tuberculosis is suspected and the lesion is accessible (as in the case of the cervix and vulva, or of the tube at laparotomy), the diagnosis is made by examining biopsy material both bacteriologically and histologically (*see below*). Otherwise, advantage is taken of the fact that the endometrium is nearly always involved and can be obtained for examination by endometrial biopsy or aspiration. Specimens should preferably be taken from

the cornual regions. The most likely time in the cycle to find evidence of endometrial tuberculosis is during the week preceding menstruation. This is because the tubercles and bacteria are mostly found in the surface layers which are shed during menstruation, and which have to be reformed and reinfected from the tubes downwards. The curettings or tissue fragments are divided into two portions and handled as follows.

The specimen is fixed and sections made for microscopic study. The finding of epithelioid clusters with giant cells is highly suggestive but not conclusive evidence unless tubercle bacilli can also be demonstrated in specially stained preparations (Figs 19.13 and 19.14). Traditional Ziehl-Neelsen staining with basic fuchsin dyes is satisfactory. Modern laboratories processing large numbers of specimens use auramine-rhodamine staining and fluorescence microscopy. This also applies to the histological examination of any tissue removed at operation. Lesions which simulate tuberculosis are foreign body giant cell reactions (such as talc granulomas) and sarcoidosis.

- At the time of operation, some endometrium or tissue is kept aside for culture. If this test is omitted, and reliance is placed on histological examination alone, endometrial tuberculosis can be missed in up to 50-75 per cent of cases. A positive culture is diagnostic. Specimens are inoculated onto egg-or agar-based medium, e.g. Löwenstein-Jensen or Middlebrook 7H10 and incubated at 37°C under 5 per cent CO<sub>2</sub>. Growth is detected after 4 to 8 weeks. Species identification is done on the basis of growth time, colony pigmentation and morphology and biochemical tests.

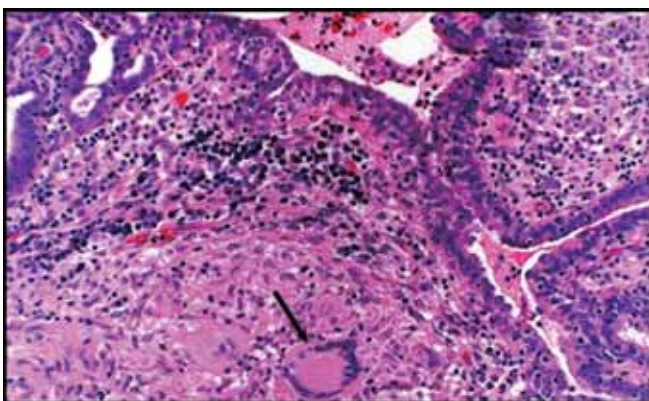


Fig. 19.13: Tuberculous salpingitis microscopic picture

In many laboratories, liquid media with radio-metric growth detection, e.g. BACTEC-460, and the identification of isolates by nucleic acid probes are used instead and these permit diagnosis in 2 to 3 weeks. The bacteriologist should also be able to report on drug sensitivity.

- PCR can be done on endometrial tissue. However, PCR may be positive even with dead bacilli and need not reflect the activity of the disease. It may also be positive with other mycobacterial infections.

If for any reasons endometrial sampling cannot be arranged, the first-day menstrual discharge is collected by pipette and this will sometimes give a positive culture. A negative finding, however, is not conclusive.

A real problem is to diagnose tubal tuberculosis in the absence of endometrial involvement. Here, laparoscopy has a place providing tuberculous peritonitis and adhesion formation can be excluded with reasonable certainty. Biopsies and washings from the cul-de-sac can be subjected to the same tests described above. Salpingography sometimes reveals characteristic tubal patterns but is unreliable, and is so dangerous from the standpoint of causing an exacerbation that it should never be carried out if there is a real possibility of the disease being present. Despite meticulous investigation it is sometimes difficult to clinch the diagnosis and repeated tests may be necessary. I know of several patients with normal pelvic organs who had to have

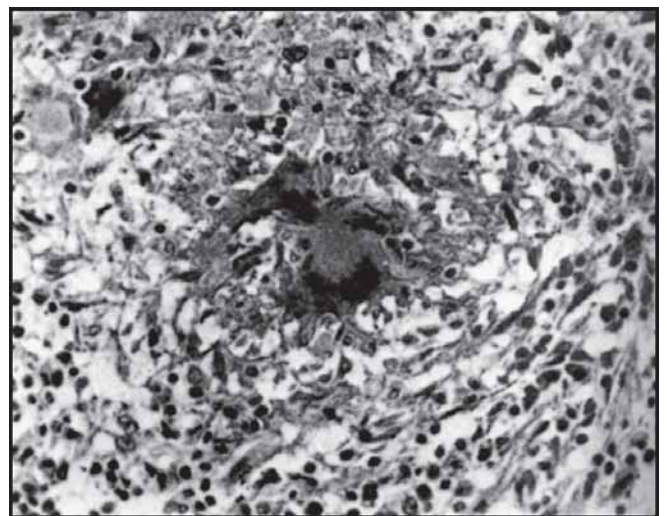


Fig. 19.14: A high-power view of the giant cells system seen in Fig. 19.13

endometrial sampling carried out three or four times over a few years before tubercle bacilli were found. It is also my practice, when carrying out tubal surgery for infertility, to send material for bacteriological culture for tuberculosis as well as for routine histological analysis.

## Treatment

The choice of treatment depends to some extent on whether genital tuberculosis is found in association with an active lesion elsewhere, and must therefore be preceded by a full investigation from this stand-point. Radiological examination of the chest and an examination of the urine for tubercle bacilli are especially important.

### General

It is important to improve the patient's natural resistance to the disease by attention to diet and general well-being. Women frequently ask whether there is any chance of their husbands contracting urogenital tuberculosis during coitus. This risk cannot be denied, although it is small and can be obviated by the use of a condom until the infection is under control.

### Antibiotics

The treatment of pelvic tuberculosis is similar to that of pulmonary tuberculosis. Initially therapy used to be given for 12 to 24 months. The introduction of rifampicin decreased the duration to less than 12 months. The realisation that pyrazinamide augments the potency of the isoniazid—rifampicin regimens led to the development of the 6-month regimen.

Five drugs are considered first-line agents for treatment of tuberculosis: streptomycin, isoniazid, rifampicin, pyrazinamide and ethambutol. The last four can be given orally and are generally preferred. The principle of treatment is to give four drugs initially for 2 months, and preferably until the drug sensitivity is known, followed by two drugs for the remaining 4 months. Patients are usually commenced on isoniazid (INH) 5 mg/kg (maximum 300 mg daily); rifampicin 10 mg/kg (maximum 600 mg daily); pyrazinamide 15-30 mg/kg (maximum 2 g daily); and ethambutol 15-25 mg/kg. Maintenance therapy is usually with INH and rifampicin in a combined tablet for 4 months. Pyridoxine 10-25 mg daily should be added to the regimen in patients at high risk of vitamin deficiency, e.g.

malnourished women, pregnant and lactating women; medical problems associated with neuropathy, e.g. diabetes mellitus, chronic renal failure, HIV infection or AIDS; and alcoholics.

Patients with tuberculosis resistant to first-line drugs are treated with second-line drugs. These have a lower degree of efficacy and a higher degree of toxicity so these patients should ideally be referred to a specialised unit. Second-line drugs include kanamycin, amikacin and capreomycin which are injectable preparations and ethionamide, cycloserine, para-aminosalicylic acid (PAS), ofloxacin, spar-floxacin, clofazimine, thiacetazone and amoxicillin/clavulanic acid which can be administered orally. Rifabutin is a long-acting rifamycin derivative under evaluation for cases resistant to rifampicin which may be effective in a once-weekly dose.

During treatment, patients should be monitored for drug toxicity. The most important and commonest of these is hepatitis.

Patients on rifampicin should be warned that their urine, saliva and other body secretions will be coloured orange-red but this should not be confused with the dark urine of hepatitis which is accompanied by loss of appetite. If there is marked derangement of hepatic function, drugs should be stopped and re-introduced one at a time after recovery. Other complications include optic neuritis with ethambutol, eighth nerve damage with streptomycin, autoimmune thrombocytopenia with rifampicin; the development of these warrants discontinuation of these drugs. Hyperuricaemia and arthralgia may develop with pyrazinamide but the drug is discontinued only if the patient develops gouty arthritis. Minor problems like gastrointestinal symptoms and pruritus are treated symptomatically without alteration of therapy.

In the case of endometrial tuberculosis, the patient is subjected to endometrial aspiration after 6 months for a test of cure.

Tuberculosis of the vulva, vagina and cervix is often cured quite dramatically by antibiotics. The results in the case of endometrial and tubal disease are more difficult to evaluate but experience suggests the following.

- By itself, antibiotic therapy is usually inadequate when chronic caseating abscesses are present.
- In the more favourable cases, with only microscopic foci, the infection is eradicated in the majority of cases. Sometimes, after an initial apparent cure, positive

endometrial cultures are obtained again 12 or more months later. This may happen in 5-10 per cent of cases.

- Cure to the extent of restoring the patient's fertility is not common, the total salvage being no more than two *live* babies for every 100 women treated.

If the tubes are closed at the outset, permanent sterility is likely and attempts at salpingostomy following suppression of the active infection may be followed by reclosure.

If the tubes are open, pregnancy is possible but, because of residual infection or of scarring and distortion of the endosalpinx, tubal implantation is likely. Indeed, ectopic pregnancy following antibiotic therapy for pelvic tuberculosis is now a recognised clinical syndrome. Abortion of intrauterine pregnancies is also common.

Reported experience and our own indicates that of *all* women treated, only 8 per cent conceive, producing on an average 1.5 pregnancies each. Of the pregnancies, 50 per cent are tubal and 20-30 per cent end in abortion, leaving only 20-30 per cent resulting in live births. The subsequent obstetrical history of one patient was abortion, live baby, ectopic pregnancy.

It is not always possible to relate subsequent fertility to treatment because spontaneous cure of the disease can happen, and because conception occasionally occurs despite the presence of active tuberculosis. *In vitro* fertilisation (IVF) is now one possible alternative.

### Surgery

When tuberculosis is localised to any site in the body, there is usually a place for excision of the affected area; this is true for genital tuberculosis where the disease can be remarkably localised and accessible. A hypertrophic lesion of the vulva which fails to respond to antibiotics may require excision.

Removal of the uterus and adnexa for tuberculous salpingitis and endometritis is often decried on the grounds that it is a dangerous operation and likely to result in a fistula or chronic sinus. If, however, the cases are well chosen, this risk is small even without antibiotic cover. Now that surgery is covered by antibiotics it is even less dangerous.

### Indications for Surgery

- Progression or persistence of active disease despite adequate medical treatment

- The presence of large inflammatory masses - pyosalpinx, ovarian abscess and pyometra. Small symptomless adnexal swellings remaining after antibiotic therapy are best not disturbed.
- The persistence of symptoms such as menorrhagia and pelvic pain after medical treatment
- Each case has to be considered on its merits but one factor which has sometimes to be considered is proved closure of the tubes. In such a case, restoration of fertility is a forlorn hope, but conservative measures may still be justified because of the development of IVF.

### Contraindications to Surgery

- Active tuberculosis elsewhere in the body
- The presence of plastic peritonitis and dense adhesions around the pelvic organs. It is in such cases that there is danger of injury to bowel, ureter and bladder. A history of tuberculous peritonitis in youth and the demonstration of bovine rather than human bacilli in the endometrium should warn off the surgeon.

### Technique

Any sort of surgery should be preceded by 3-6 weeks' treatment with antituberculous drugs, in full dosage, and followed by the full course of treatment. When tuberculosis affects the upper genital tract the appropriate surgical procedure is usually total hysterectomy and bilateral salpingectomy. If the ovaries are obviously involved, and even if they look normal in a woman over the age of 45 years, they are usually removed as well. In a younger woman, however, I always conserve at least one ovary if it looks reasonably healthy, trusting antibiotics to eliminate any microscopic foci in it. I have never seen harm come from this practice.

## SARCOIDOSIS

Although not an infection, sarcoidosis is included here for comparison with genital tuberculosis. Sarcoidosis is mainly seen in peoples living in temperate climates - in Europe and North America. It is a granulomatous disease of the reticuloendothelial system with a wide distribution throughout the body. It occurs as a rarity in the uterus, tubes and ovaries, often symptomless but sometimes giving rise to a complaint of infertility. The diagnosis is

a histological one, the lesions having microscopical appearances similar to those of tuberculosis with follicles consisting of an aggregation of epithelioid cells and a variable number of giant cells surrounded by a *narrow* zone of lymphocytes. Complete absence of caseation and a relative scarcity of lymphocytes distinguish it from the tuberculosis follicle (Fig. 19.15).

Active sarcoidosis appears to be the result of an exaggerated cellular immune response to antigens, self or non-self, which stimulate predominantly or helper-induced T cell response.

Sarcoidosis is self-curative in 50 per cent of cases but resolution can leave permanent tissue damage—in the fallopian tubes, for example. Nevertheless, it is best left untreated or attention paid only to relief of symptoms. The lesions disappear when corticosteroids are administered but return as soon as treatment is suspended.

### ACTINOMYCOSIS

Actinomycetes, most often *Actinomyces israelii*, are occasionally found to be the cause of pelvic infection. Since the majority of infections reported in the past involved the right adnexum it was considered that the source of infection originated in the caecum or appendix or occurred as a result of bloodstream spread.

Presently, an association between the use of an intrauterine contraceptive device (IUCD) and this infection is recognised and it is postulated that the vagina

is the portal of entry. Actinomycetes have been noted in cervical smears taken from asymptomatic IUCD wearers. The disease usually develops after at least 2 years of IUCD use. The organisms may persist in the genital tract for some time after the removal of the IUCD. Other possible routes of entry may be by orogenital sex, ascent from the rectum or spread from the appendix.

The clinical manifestations of pelvic inflammatory disease caused by actinomycetes in association with an IUCD are more likely to be chronic rather than acute: fever, weight loss, abdominal pain, abnormal vaginal bleeding, discharge. Endometritis may progress to the formation of an adnexal mass or a tubo-ovarian abscess. A delay in diagnosis can lead to a 'frozen pelvis' which has to be differentiated from endometriosis or disseminated malignancy.

Pseudomycelial-like clumps of organisms are seen in the Pap smear along with positive staining for fluorescein isothiocyanate-labelled antisera against *A. israelii*. For women who are symptomatic but do not have an adnexal swelling, the IUCD should be removed and sent for culture. Prolonged courses of penicillin for 6-12 months are recommended. Tetracycline is recommended for patients allergic to penicillin. Erythromycin, minocycline, clindamycin and cephalosporins can also be used but metronidazole and aminoglycosides are unreliable. If patients with pelvic masses do not respond to antibiotics, surgical excision of the masses may be required in addition. Asymptomatic patients are not treated.

### SCHISTOSOMIASIS (BILHARZIA)

Genital schistosomiasis is seen in all tropical and subtropical countries, notably Egypt, other countries such as Africa, India, Malaysia, Indo-China, and Central and Southern America, where the causal worm and its immediate host — a water snail — are prevalent. The worm, *Schistosoma haematobium* having entered the skin from infested water, spreads by the blood-stream to invade the tissues where it deposits ova which cause local inflammatory reactions. Adult *S. haematobium* worms live in the genitourinary veins. The lesions are predominantly in hollow viscera, especially the bladder and rectum, but any part of the genital tract from the vulva to the ovaries can be involved. The commonest genital site is the cervix; vulvar lesions are mostly seen in children. The infestation is chronic and can persist for a lifetime, the carrier

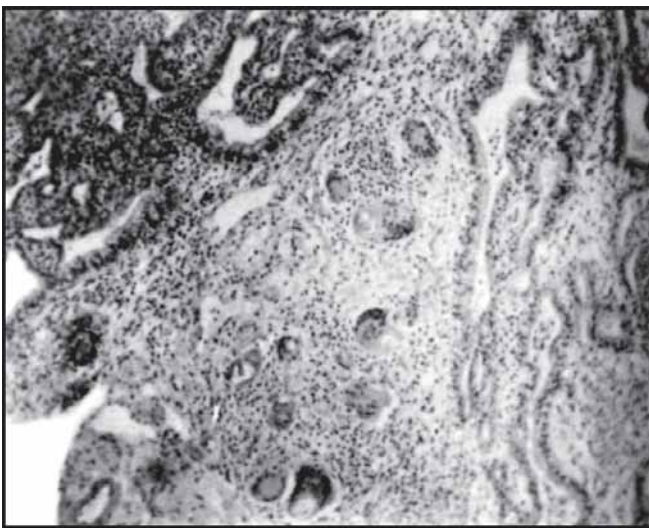


Fig. 19.15: Sarcoidosis of the tube

continually excreting ova which contaminate the environment.

The inflammatory reaction is a severe one with each ovum being surrounded by a giant cell, epithelial cells, lymphocytes and eosinophils. In some respects the microscopic appearances resemble those of tuberculosis.

Bladder and bowel symptoms predominate and the discomfort referred to the reproductive organs varies with the site infected. Schistosomiasis of the vagina and cervix can cause discharge, bleeding and dyspareunia; it also favours infertility in that antibodies to the disease are spermatotoxic.

To the naked eye the disease appears in the form of nodules, plaques, ulcers or papillomas with surrounding induration. On the cervix the disease can simulate erosion and leucoplakia. In any site it can be mistaken for cancer. It is suggested that schistosomiasis occasionally favours the development of cancer.

Praziquantel is effective against all human schistosomes and the dose is 40 mg/kg as a single oral dose. The organophosphorus compound metrifonate is only effective against *S. haematobium* infections and is given orally.

The prognosis is good for treatment in the early stage but poor in the late stages of the disease.

## AMOEBIASIS

Amoebiasis of the genital tract occurs at any age wherever intestinal infection is common, that is amongst the less-privileged communities living in warm climates. The parasite (*Entamoeba histolytica*) spreads from the lower bowel when standards of hygiene are poor. It causes ulcerative lesions in the vagina, cervix and endometrium and these can be mistaken for cancer on naked-eye examination.

Apart from any bowel symptoms, the patient complains of a blood-stained purulent vaginal discharge. The diagnosis is made by the microscopic demonstration of the parasites in stools, vaginal discharge and tissue sections; the finding of the organism incidentally during cervical cytology is also described. A negative gel diffusion precipitation test, or amoebic latex agglutination test, carried out on serum, excludes active disease but a positive finding may only mean a previous infection.

The treatment of choice is metronidazole in large doses, 400-750 mg three times daily for 5-10 days. Metronidazole is relatively ineffective in chronic asymptomatic intestinal amoebiasis in which only cysts are present in the stool. In these cases diloxanide furoate is the drug of choice.

# CHAPTER 20

## Infections as They Affect Individual Organs

Vulvitis	333	Oophoritis	356
Bartholinitis	338	Pelvic Peritonitis	356
Vaginitis	339	Pelvic Cellulitis	357
Cervicitis	347	Pelvic Inflammatory Disease	359
Endometritis	349	Suppurative Thrombophlebitis	
Metritis	350	of the Pelvic Veins	360
Salpingo-oophoritis	350		

### VULVITIS

#### Pyogenic Infections

##### *Infection of Abrasions and Wounds*

Local injuries or abrasions resulting from sanitary towels and tight underclothing — often impregnated with irritant detergents left from washing — are common sources of vulvar dermatitis. Excoriation of the skin can also be caused by vaginal discharge, and by ammonia liberated by urea-splitting organisms when the vulva is exposed to constant leakage of urine. All these lesions can become secondarily infected to cause local pain and tenderness. Treatment consists of rest, warm baths and removal of the cause.

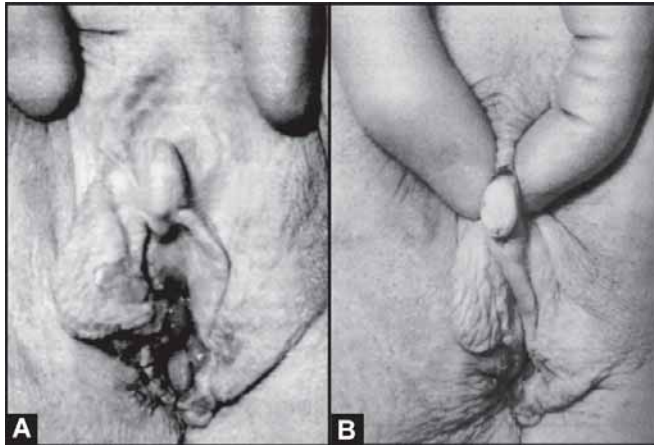
##### *Intertrigo: Smegma Concretions*

Lack of cleanliness leads to a collection of irritating sebum and other secretions in the skin folds, and secondary infection follows. The only treatment required is care over hygiene.

Inattention to the skin in the area of the clitoris can result in the collection of a concretion of smegma resembling a small stone under the prepuce. This may have to be removed (Figs 20.1A and B).

##### *Furunculosis*

Infection of vulvar hair follicles leads to boils and carbuncles which are sometimes recurrent. Glycosuria must be excluded in such cases. Otherwise, recurrent boils mean that pathogenic staphylococci are being harboured in a carrier site (for example, the nose or axilla) of the patient or of a close associate. These have to be found and eliminated. For the vulvar skin the remedies are scrupulous attention to cleanliness, swabbing with an antiseptic solution and regular applications of topical



**Figs 20.1A and B:** A smegma concretion beneath the prepuce of the clitoris. Patient aged 70 years with a carcinoma of the fourchette extending onto the perineum, (A) The hidden concretion gives the appearance of a tumour or of hypertrophy of the clitoris, (B) The concretion being expressed; in this case a small incision was necessary to provide an exit

antibiotics. During a phase of active furunculosis, a full course of treatment with penicillin, or of other antibiotic appropriate to the infecting organism, should be given *systemically*, not locally.

#### *Infection of Sebaceous and Apocrine Glands*

Single abscesses, often representing secondary infection of a retention cyst of an apocrine or sebaceous gland, have the clinical characteristics of a boil and are treated in the same way. If they recur in the same site the underlying cyst has to be excised when free from inflammatory reaction.

*Hidradenitis suppurativa*, which is rare and more likely to be seen in hot climates, is a condition of chronic bacterial infection of many apocrine glands which shows periodic exacerbations. It occurs in the axilla and the vulva but only after puberty when the glands become active. On the vulva the disease presents as a series of tender nodules which suppurate and coalesce to form abscesses. Sinuses develop and these extend deeply and widely.

Radical and repeated incisions to lay open all abscesses and tracts, combined with antibiotics, is the treatment. Diffuse hidradenitis, however, is very refractory and in healing leaves extensive scarring and distortion.

#### *Infantile and Senile Vulvitis*

When the vulvar epithelium is thin and inactive, as in childhood and old age, any of the organisms to which it is normally resistant can set up a simple vulvitis. This sometimes leads to labial adhesions. This type of vulvitis is often associated with vaginitis. Its clinical features and management are described elsewhere.

#### **Acute Simple Ulcers (Figs 20.2A to C)**

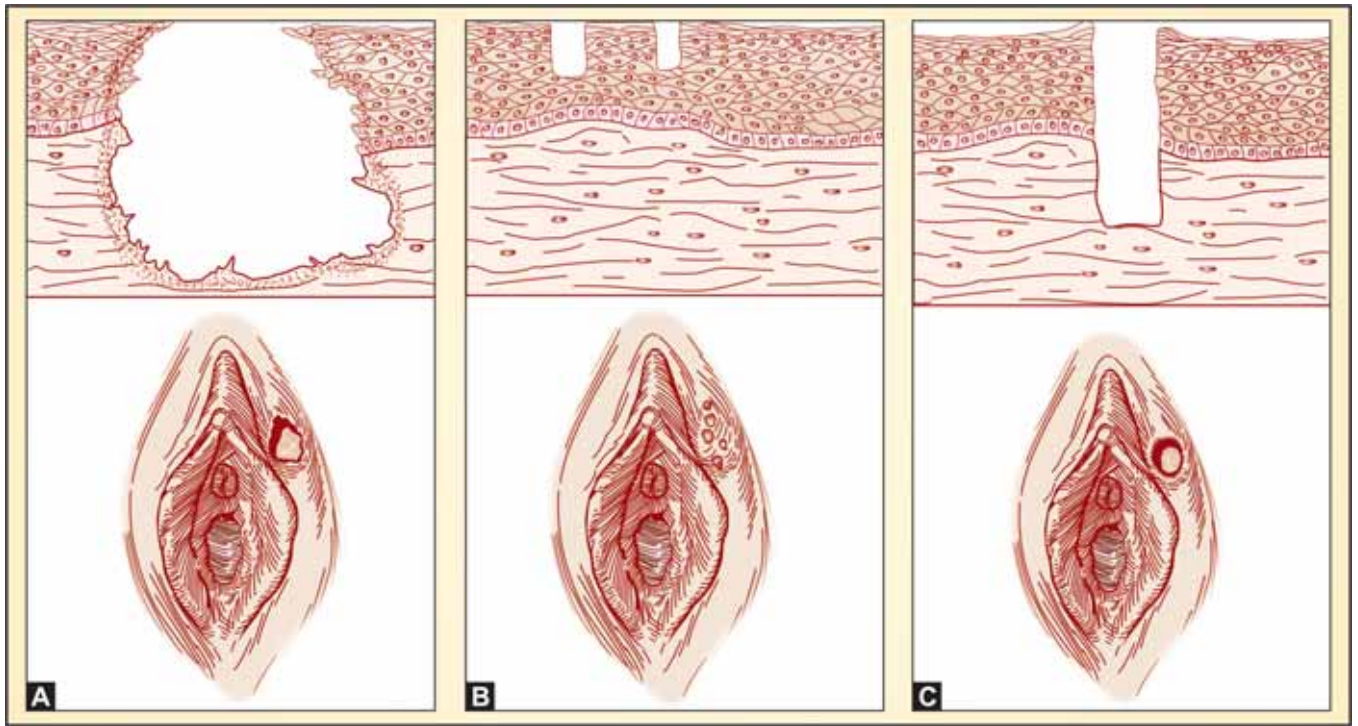
##### *Herpes Genitalis*

Changing sexual habits in the last few decades have been associated with an increased incidence of genital herpes. Indeed, genital herpes simplex infections now have a higher incidence than syphilis and are the most common cause of genital ulceration in industrialized nations. Genital herpes is important not only because of its increasing incidence but also because of the physical and psychological trauma it can induce, the risk of serious complications including a link with cervical cancer and the risk of transfer of maternal infection to neonates. Disseminated herpes in the newborn is certainly one of the most severe manifestations of herpes infection. Prematurity and spontaneous abortion have also been associated with active maternal genital herpes.

Herpes simplex genitalis is most often caused by infection with herpes simplex virus (HSV) type 2 (85%), which has usually been sexually transmitted by an infected partner, but may possibly be transmitted by orogenital contact. HSV type 1 infection accounts for about 15 per cent of cases. Infection is transmitted by secretions containing the virus and not by fomites or aerosolization, as the virus is readily inactivated at room temperature or by drying.

Genital diseases caused by either of these viral types are clinically indistinguishable. As with other herpes infections, the virus replicates in the epithelium giving rise to painful symptoms and signs. These typically, but not invariably, follow a course which commences with redness and inflammation, leading to the formation of vesicles which progress to pustules. These pustules then erode to form multiple, small and shallow ulcers found on the labia and around the introitus. Lesions may also be found in the urethra and vagina, on the cervix and, occasionally, on the thighs and buttocks. These coalesce to form larger ulcers and resolve with crusting and healing. This cycle may take up to 3 weeks in a primary





**Figs 20.2A to C:** Showing the appearance of the ulcers of chancroid (A), herpes (B), and syphilis (C). The ulcer of chancroid has irregular margins and is deep with undermined edges. The syphilis ulcer has a smooth, indurated border and a smooth base. The genital herpes ulcer is superficial and inflamed. (Modified from Schmid GP, Shcalla WO, DeWitt WE. Chancroid. In: Morse SA, Moreland AA, Thompson SE, eds. Atlas of sexually transmitted diseases. Philadelphia, PA: JB Lippincott, 1990)

infection. After a primary infection, the virus remains quiescent in the sacral ganglia and can reemerge to cause recurrences at a later time. The symptoms of recurrent genital herpes tend to be milder and of shorter duration, and are often preceded by a prodromal phase consisting of cutaneous itching or burning, and redness in the affected region. The frequency of recurrence can vary from days to years. Rarely, herpes genitalis can also cause meningitis, encephalitis and hepatitis.

#### *Diagnosis and Management*

The presence of multiple painful ulcers is suggestive of the diagnosis but other causes of multiple painful ulcers like Behçet's disease, chancroid, Stevens-Johnson syndrome and vulvitis should be excluded. In all instances a search should be made for extragenital lesions.

When genital herpes is suspected it is important to confirm the diagnosis with laboratory culture, if possible, which also permits subtyping of the virus and can be

done within 1-4 days of the infection. HSV antigen detection by enzyme immunoassay (EIA) or fluorescent antibody (FA) and HSV DNA detection by polymerase chain reaction (PCR) are also possible. Serodiagnosis is useful in documenting first episode infection but in recurrent infection there may be no rise. Once the diagnosis is made a sympathetic explanation should be given to the patient, who may be very upset. The natural history of the disease should be explained and advice given on genital hygiene. It is obviously important to trace sexual partners, and it would be wise to inform the obstetrician if the patient is pregnant. In view of the possible link with cervical cancer, a cervical smear once a year would be a sensible precaution.

Acyclovir (ACV) is the therapy of choice in primary herpes simplex genitalis and in severe recurrent attacks. It is an acyclic nucleoside analogue that is a substrate for HSV-specific thymidine kinase. In primary genital HSV infection, oral ACV (200 mg 5 times daily for 10-14 days), topical ACV (5% in polyethylene glycol in aqueous

ointment) or intravenous ACV (5 mg/kg 8-hourly for 5 days) can decrease the severity and duration of symptoms and reduce viral shedding, while preventing the development of new lesions.

Concomitant urethral, cervical and oral infections are common in first episode infection so oral therapy is preferable to topical. Symptoms are reduced within 48 hours. The duration of viral shedding is also decreased with antiviral therapy. Doses of 400 mg thrice daily have also been used but there does not appear to be any benefit in prescribing higher doses of 800 mg 5 times daily, nor is there any benefit in combining topical with oral medication.

ACV has a very low toxicity to cells which are not infected with herpes simplex.

In very severe attacks, for patients in hospital or patients with serious complications, intravenous acyclovir may be appropriate.

In recurrent disease, oral acyclovir, famciclovir and valcyclovir have all been shown to help in reducing the duration of the episode. Treatment should be initiated by the patient herself as soon as she notices the first sign or symptom of recurrence. If the patient is immunocompetent, therapy may not always be required as the episodes are self-limiting. Measures like local application of calamine lotion may provide relief. The topical preparation in aqueous base may provide better relief than the polyethylene glycol base.

Suppressive therapy with long-term ACV therapy (200 mg thrice daily or 400 mg bd) has been used in some women having 4 to 12 episodes per year and who are emotionally disturbed or in severe physical discomfort. No serious side-effects have been reported. Treatment should be interrupted every 12 months to reassess the need for continued therapy.

Acyclovir has been used in pregnancy, even in the first trimester, and no significant anomalies or side-effects have been noted. However, the numbers are yet not many and it should be used with caution.

If secondary infection is present it should be treated. Patients should be advised to have regular cervical smears, to avoid intercourse when lesions are present and to inform their medical attendants of a past history of herpes when pregnant.

Syphilis (chancroid) is the next common cause of sexually transmitted genital ulcers (Fig. 20.2A to C). Diagnosis is made, based on history, clinically and serological test for syphilis. A painless, minimally tender

ulcer without lymphadenopathy is likely to be syphilitic ulcer. May also present as vesicles mixed with small ulcers. Chancroid is usually one or two extremely painful ulcer with tender lymphadenopathy. Also inguinal bubo with ulcer is likely to be chancroid and without ulcer it is likely to be LGV.

### Recurrent Genital (and Buccal) Ulceration

This is a not uncommon condition and the ulcers, identical in appearance with those described above, may be on the vulva alone, in the mouth alone, or simultaneously in both sites. When it is associated with conjunctivitis it becomes part of *Behçet's syndrome*. It is not sexually transmitted. The clinical features, aetiology and treatment are described elsewhere.

*LGV and granuloma inguinale (Figs 20.3 and 20.4):* Lymphogranuloma inguinale and granuloma inguinale (donovanosis) are rare sexually genital diseases. These are associated with an increased risk for HIV infections.

### Tuberculosis of the Vulva

*Abrasions:* Due to injury see elsewhere.

*Fixed drug eruptions:* rare.

### Schistosomiasis

*Carcinomas:* see elsewhere.

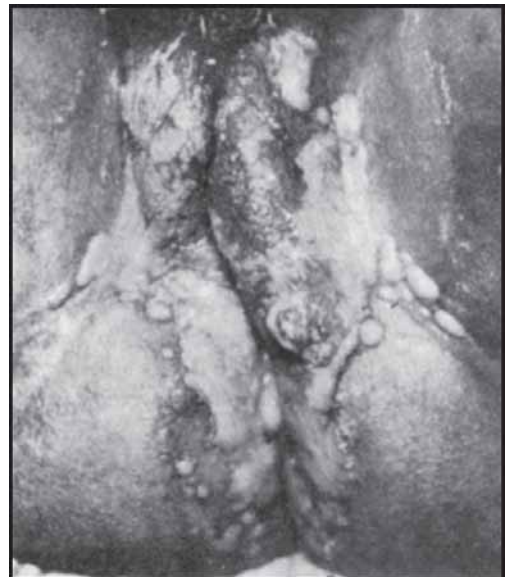


Fig. 20.3: Granuloma inguinale



Fig. 20.4: Condyloma acuminata of the vulva

### Noma Vulvae; Tropical Ulcer; Phagedaena

This is a condition of acute necrosis or gangrene of the tissues of the vulva often associated with a fusospirochaetal infection. This is a term covering two microorganisms living in symbiosis — *Fuso-bacterium* and *Spirochaeta*. Both live anaerobically and can exist in a nonpathogenic form in the mouth and on the vulva. When found on ulcers they are considered by some to be secondary invaders rather than causal agents. It can arise as a complication of acute infectious fevers in debilitated children but is now rare in outside tropical countries. In these it is still seen in destitute malnourished children and adults. Because of the underlying debilitation of the patient, the condition can be fatal.

### Diabetic Vulvitis

Glycosuria, whether it be due to diabetes mellitus or not, causes a diffuse inflammation which gives the vulvar skin a typical purplish red appearance. The symptom is intense pruritus. Although chemical changes in the epithelial cells may play a part, the vulvitis is mainly the result of infection with *Candida albicans*, this organism thriving in the presence of carbohydrates with which the vulva is contaminated. Treatment consists of controlling the glycosuria, and in instructing the patient to wash the vulva free from all urine (and sugar) immediately after micturition. Sponging with 1 per cent

sodium bicarbonate solution gives temporary relief from pruritus but the specific remedies for the infection are local applications of ointments or powders containing one of the fungicides described elsewhere. An ointment combining a fungicide with hydrocortisone is especially helpful.

### Candidiasis

*Candida* infection of the vulva also occurs without glycosuria and may or may not be associated with a similar infection of the vagina, perianal skin, hands and feet. It not infrequently follows the use of antibiotics which interfere with the normal flora of the vagina and bowel.

The appearance of the vulva varies from a diffuse erythema to pallor and oedema, and is sometimes similar to that seen in diabetic vulvitis.

Candidiasis typically causes pruritus vulvae. Its diagnosis and treatment are described on page 343.

### Tinea Cruris (Ringworm)

Fungal infection of the vulva is rare in women, or at least is difficult to prove. Nevertheless, irritating vulvar skin changes are not uncommon in women suffering from some sort of fungus infection of the feet and hands.

### Pediculosis Pubis

This affects the pubis rather than the vulva. The 'crab louse', *Phthirus pubis*, infects the hair-bearing area of the mons, and the parasites or their eggs can be seen clinging to the hairs. The infection is transferred from one individual to another by contaminated clothing or by close bodily contact including intercourse. The underlying cause is uncleanliness, the symptom pruritus. Treatment consists of shaving the vulva, frequent washing, and applications of malathion lotion or shampoo, or other pediculocides. Clothing has to be decontaminated.

### Elephantiasis

This is a condition of chronic lymphatic oedema with associated thickening and hypertrophy of the epithelial tissues of the vulva. The skin is rough, warty and weeping. True elephantiasis is caused by infestation with the filarial worm *Wuchereria bancrofti*, but this is rare in temperate zones where the more common cause of lymphatic obstruction is any chronic infection which

heals by fibrosis. So it is seen as an end result of healed tuberculosis, lymphogranuloma venereum, granuloma inguinale and possibly syphilis, and is then called *false elephantiasis* (Fig. 19.6). Occasionally the cause is obscure.

If the condition is severe enough to cause discomfort or dyspareunia, the affected tissue has to be excised. Even then it may recur despite the discovery and treatment of the underlying infection.

### Other Infections

All types of infection can involve the vulva on occasion. Those worthy of mention are diphtheria, actinomycosis and tetanus; also any form of skin disease with an infective basis.

## BARTHOLINITIS

### Aetiology

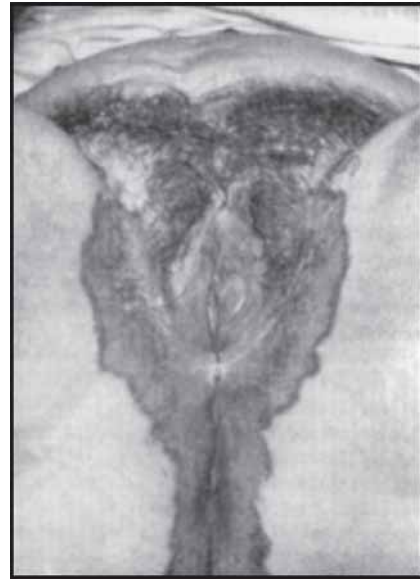
The occurrence of bartholinitis always raises the suspicion of a gonococcal infection but the disease can be caused by *Escherichia coli*, *Staphylococcus*, *Streptococcus faecalis*, *Streptococcus pneumoniae*, *Haemophilus* spp., *Trichomonas vaginalis* and, indeed, by any pyogenic organisms. Chlamydial infection may be present alone or in combination with the gonococcus. The role of bacterial vaginosis is unclear.

### Pathology

Both duct and gland are involved and show the usual inflammatory reactions. The lining of the duct becomes swollen and its orifice can be seen as a small red macula of congestion. Acute bartholinitis may resolve completely but frequently an abscess forms and ultimately discharges through the lower vaginal wall. The infection sometimes persists in the chronic form with periodic exacerbations and abscess formation. The gland then becomes permanently enlarged and fibrotic so that it can be felt between the fingers like a small hard pea. The duct often heals by fibrosis with closure of the orifice; this leads to cyst formation. Many Bartholin 'abscesses' are secondarily infected cysts.

### Clinical Features

The complaint is one of local discomfort which becomes very severe when an abscess forms. An acutely tender swelling appears beneath the posterior part of the labium



**Fig. 20.5:** Psoriasis of the vulva. Note the extent of the lesion extending laterally to the inner thighs, and posteriorly to involve the perianal skin and cleft

majus extending inwards to the base of the labium minus. The overlying skin is reddened and the surrounding tissues indurated and oedematous. The position of the swelling at the junction of the anterior 2/3 and posterior 1/3 of the labium majorum is diagnostic (Fig. 20.6). The differential diagnosis is from adenoma and hamartomas, and in older women, from carcinoma.

### Treatment

This consists primarily of rest in bed, the administration of antibiotics to cover gonococcal and chlamydial infection, as well as anaerobic bacteria and the relief of pain with analgesics and warm baths. When it is certain that an abscess has formed, free drainage is established by an incision placed *outside* the introitus; this is better than allowing the abscess to burst spontaneously. The operation of choice, however, is to marsupialize the edges of the abscess cavity to the skin of the introitus. By providing permanent drainage this reduces the chance of subsequent cyst or abscess formation. The operator should wear protective goggles.

Excision of the gland and duct cannot be carried out while active infection is present but is indicated in the intervals between recurrent abscess formation when the gland remains palpable. This operation is more difficult than it sounds.



**Fig. 20.6:** A small left-sided Bartholin abscess which is distorting the vulva and pointing just within the introitus

## VAGINITIS

### Vaginitis (Vulvovaginitis) in Infancy

#### *Aetiology and Pathology*

Although local infection in infancy is essentially one of vaginitis, the urethra and vulva are usually involved as well. The common age is 1-5 years. The infection arises because vaginal resistance has not developed and the organisms are transmitted from adults or from another child by hands, clothing or utensils. The most serious form of infection is gonococcal, but this is now rare and other organisms such as *Candida albicans*, *Streptococcus*, *Staphylococcus*, *Escherichia coli*, the *Pneumococcus* and even *Trichomonas vaginalis* are more likely to be found. Threadworms (*Enterobius vermicularis*) can infest the infantile vagina as well as the lower bowel.

Occasionally the basis of the infection is a foreign body inserted into the vagina by the child. The accidental entry of sand or shreds of clothing, especially from woollen pants, is another possibility.

#### *Clinical Features*

The main symptom is a purulent discharge but the child may also complain of pain and soreness of the vulva. These interfere with walking and cause dysuria. In a

young child often the parent notices her crying during urination or scratching herself. The vulva is reddened, sometimes oedematous or excoriated, and bathed in discharge. If the discharge is bloodstained, the presence of a foreign body, or some other condition such as a cervical polyp (even the rare sarcoma botryoides), should be suspected and excluded.

#### *Diagnosis*

The diagnosis of infantile vulvovaginitis is usually obvious but the causal organism can only be determined by examining (including culturing) the discharge obtained by a swab or fine pipette inserted through the hymeneal opening. This also excludes the possibility of leucorrhoea of infancy exaggerated by a fussy mother. Digital vaginal examination is not possible, but if a small girl is laid on her side it is surprising how much of the vagina can be visualized. Rectal examination may enable a foreign body to be felt by counter-pressure against the symphysis pubis or against a hand placed on the abdomen. Ordinarily, however, the presence of a foreign body is excluded by sonography, examination under anaesthesia, and inspection of the upper vagina through an aural or nasal speculum, a baby's laryngoscope, or a hysteroscope (vaginotomy), or by radiography.

#### *Treatment*

Any foreign body must be removed; for this purpose, aural forceps can be useful. Otherwise, treatment consists of administering antibiotics or fungicides, modifying the dose to suit the age of the patient. Treatment for pinworms is instituted where required.

If the vulva is sore and excoriated the child should be kept at rest and the vulva sponged regularly. Adhesions of the labia can be prevented by applications of oestrogen cream locally.

It is necessary to take steps to prevent the spread of infection to the conjunctiva and *to other children*. It is also important to avoid the young child becoming morbidly interested in her genital organs, which she quickly does – especially if the mother is overanxious.

### Senile Vaginitis (Atrophic Vaginitis)

#### *Aetiology and Pathology*

This is caused by any of the common pyogenic organisms invading tissues which have lost their resistance. Senile

endometritis or vulvitis is sometimes present as well. The vaginitis is often *granular*, that is, it appears as small multiple reddened areas which are mostly seen in the vault and around the urethral orifice. Patchy ulceration can result in adhesions forming between the anterior and posterior walls to produce partial closure of the vagina — *adhesive vaginitis*.

### Clinical Features and Diagnosis

The main complaint is postmenopausal yellowish discharge, sometimes bloodstained, which causes excoriation and soreness of the vulva. Dysuria (from urethral involvement) and a sensation of fullness in the vagina are also common.

The diagnosis can only be made by excluding other possible causes of postmenopausal discharge—senile endometritis or cancer of some part of the genital tract. Examination under anaesthesia, diagnostic curettage and cervical cytology or biopsy are therefore essential in all cases before vaginitis is assumed to be the cause of symptoms.

Even if vaginitis is present, the patient may still have carcinoma of the uterus as well.

Senile vaginitis should not be diagnosed merely on the finding of a speckled red vagina for this can be a normal climacteric change. A discharge must also be present.

### Treatment

The vaginal resistance is quickly restored by giving any of the oestrogen preparations in full dosage for 3 weeks, followed by an interval of 1 week and then repeated if necessary. Oestrogens can also be given locally, in the form of a cream to be inserted into the vagina each night. By any route they may induce uterine bleeding and the patient should be warned of this. Any uterine bleeding must be reported, however, as further investigation is then justified to exclude any more serious cause of postmenopausal bleeding.

Local treatment with antiseptics or antibiotics is usually unnecessary.

When hormone therapy is suspended the vagina atrophies again but, if the infection has been eradicated, the disease should not relapse.

## Trichomonas Vaginitis and Urethritis (Trichomoniasis)

### Aetiology

This is the most common form of vaginitis and is found in approximately 50 per cent of women complaining of vaginal discharge and in 60 per cent of those with proven gonorrhoea. It occurs at any age from birth onwards but most often in the young adult.

The *Trichomonas* group of organisms is a large one and certain members are commonly, if not normally, found in the mouth, bladder and large bowel. *Trichomonas vaginalis*, which is responsible for vaginitis, has morphological characteristics slightly different from the others. It is an ovoid motile flagellated parasite 15–20 µm in length and 8–10 µm in width, although smaller forms are described. It has four anterior flagella and an axostyle which traverses its body to end in a spike (Fig. 20.7).

In the vagina the parasite is invariably accompanied by staphylococci, streptococci, enterococci or coliform organisms but it is the trichomonads and not these which cause the vaginitis.

The infection is often contracted during intercourse with a male harbouring the organisms in the prepuce,

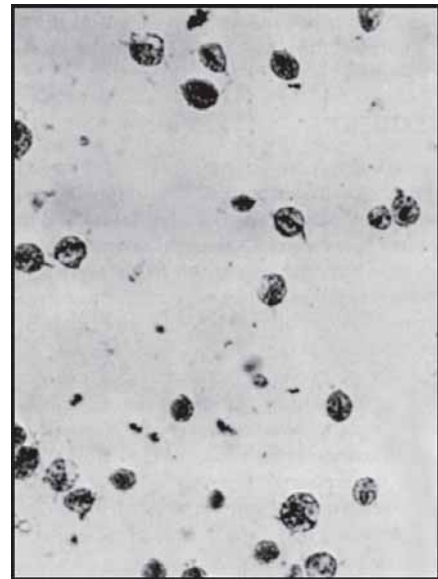


Fig. 20.7: *Trichomonas vaginalis* organisms, as seen in a preparation made from cultures of vaginal discharge

urethra or prostate, the incubation period being 3-28 days. The partner of a man with proved *Trichomonas* infection can nearly always be shown to carry the organisms. Some say that trichomonads can be found in the urethra of 2 per cent of *all* men and in 10 per cent after prostatic massage. Estimates of their frequency in cases of male nonspecific urethritis vary from 5 to 70 per cent, depending possibly on the efficiency of the tests. Nevertheless, the male carrier is generally symptom-free and it has clearly been shown that a man can transfer the organisms from one woman to another without himself developing any signs of the disease.

This does not mean that *Trichomonas* vaginitis is *always* venereal in origin. It is not uncommon in virgins, children and old women. Transfer of the organism from one individual to another by indirect contact certainly happens. Contaminated domestic towels, bed linen and personal clothing, improperly sterilized surgical instruments such as specula, bath tubs and possibly swimming pools are likely media for transfer. Patients sometimes date the onset of symptoms to a stay in hospital where they may be exposed not only to infection by certain of the above means, but to diseases and treatments which convert a carrier to an infected state. Twenty per cent of asymptomatic pregnant and nonpregnant women harbour the parasites in the vagina so, if debilitating illness lowers their resistance, or if they are given antibiotics which alter the vaginal flora, the disease can become manifest.

The effect of lowered local resistance is well illustrated by the fact that *Trichomonas* vaginitis often first manifests itself immediately after a menstrual period — during which the vaginal pH is raised. The optimum pH for the trichomonads is 5.5-6.5 and this or a slightly higher level is usually found in the vagina when the disease is present.

### Pathology

The infection is essentially of the vaginal epithelium and the parasites shelter between the rugae. It is possible that they may penetrate between the surface cells but no deeper, and they induce the usual tissue inflammatory reaction. In 70 to 80 per cent of cases the trichomonads can also be cultured from the urethra, where they cause acute or chronic urethritis. Bartholin's glands and Skene's tubules are sometimes infected.

*Trichomonas* endocervicitis is also postulated but it is doubtful whether it exists as a clinical entity. There are

reliable reports of the organisms having been found in the cervix, the body of the uterus, the fallopian tubes and even in the bloodstream, but their significance in these sites is questionable.

### Clinical Features

The first symptom is usually a *sudden* onset of purulent vaginal discharge, often dating from menstruation. It is said to be cream-coloured and frothy but its physical characteristics vary widely. It may be profuse or scanty and the most constant feature is that it causes pruritus, the itching being felt around and within the introitus. At the outset, dysuria and frequency of urine are also common complaints. Vaginal tenderness and congestion result in dyspareunia.

In the acute stage the labia minora and introitus are sometimes oedematous. The vagina may be diffusely fiery red in colour but often presents a strawberry appearance which, on the cervix, can be confused with erosion. The external urethral meatus is congested and pouting. Later, or when the reactions are less severe, the disease is manifested by a 'granular' vaginitis which is most obvious in the fornices, on the portio vaginalis and around the urethral orifice.

The infection can become very chronic with pruritus more prominent than discharge, and is subject to periodic exacerbations over the course of many years. The same is true of the urethritis; so '*recurrent cystitis*' in women is *very often explained by flare-ups of a persistent Trichomonas urethritis*. This sort of chronic infection is also the main if not only cause of the *pseudocaruncle* or *granulomatous caruncle* of the urethra which is so often mistaken for a true caruncle.

### Diagnosis

The diagnosis should be suspected in all cases where discharge causes pruritus but is made certain by demonstrating the presence of *T. vaginalis* organisms. Not infrequently they are discovered incidentally during routine cervical cytology. Ordinarily, however, they are looked for in the vaginal discharge or, in cases of suspected urethritis, in swabs taken from within the urethra. A single negative test is never conclusive and several studies may have to be made before the parasites are found.

In the office, a wet smear preparation can be made. Specimens, uncontaminated by lubricant, are taken from the vagina or urethra by a swab or pipette and can be

examined immediately microscopically. For this purpose the material is mixed with saline solution on a warm slide, covered with a glass slip, and left unstained. The trichomonads are recognized by their shape, size (larger than a pus cell but less than half the size of a vaginal squame) and by their motile flagella and rotatory movements.

However, this 'bedside' examination is very unreliable. Culture methods are more accurate. The specimen of discharge, or preferably the whole cotton tip of the swab, is added immediately to a small tube of Kupferberg's or Feinberg-Whittington medium. The latter is a proteolysed liver and inactivated horse serum preparation with streptomycin and penicillin added. It eliminates all organisms except *Trichomonas* and *Candida albicans*; these thrive. Incubation preferably at 34°C rather than at 37°C, is followed by examination of drops of the fluid for organisms at 24 and 48 hours and, if need be, later. Providing care is taken to make sure the culture medium is satisfactory, this method reveals *T. vaginalis* in twice as many female patients as does direct microscopic examination of discharge. It is the only means of reliably testing the male.

The finding of *Trichomonas* vaginitis indicates a need to exclude gonorrhoea as well. *Candida* and *Trichomonas* infestations also commonly coexist but the dual nature of infection is not always evident until the dominant organism (*Trichomonas*) has been eliminated. The persistence of symptoms after treatment with trichomonacides therefore calls for repeated cultures for both *Candida* and gonococci.

### Treatment

Systemic therapy is superior to topical therapy because *T. vaginalis* often infects the urethra and periurethral glands. These organisms can result in subsequent reinfection. The recommended regime is metronidazole, 2 g in a single oral dose, for both partners. An alternative regime in case of single-dose failure is one tablet of 400 mg given twice daily by mouth for 1 week or 2 g once daily for 3-5 days. For children less than 12 years of age the corresponding dose is 200 mg (half a tablet) and for infants, 50 mg administered with the same timing as for the adult.

Whilst under treatment the patient should be told of the need for care in the disposal of her underclothing and to keep her own bath towel, in order to minimize

the chance of her infecting other female members of the family. She should also be warned against coitus. The physical effect is irritant to inflamed tissue and the male partner may become infected.

As many as 60 per cent of the husbands of women suffering from *Trichomonas* vaginitis can be shown to harbour the parasite in the urethra and its associated glands, or beneath the prepuce. Unless, during the period of abstinence, the organisms disappear spontaneously from the male urogenital tract, resumption of coitus when the wife's treatment is complete results in her being reinfected. Because of this it is important to treat the consort of every woman suffering from *Trichomonas* vaginitis. He is given metronidazole simultaneously and in the same dosage.

Even in standard dosage metronidazole sometimes causes slight nausea, metallic taste, dizziness, headaches and minor skin eruptions but these rarely necessitate interruption of the treatment. Transient neutropenia with WBC counts of 1000-1400/mm<sup>3</sup> have been reported in 7.5 per cent of patients treated with multiple doses of metronidazole. Metronidazole has also been reported to prolong the prothrombin time in patients on warfarin.

It has never been shown to be teratogenic in animals but, lest it have a mutagenic effect on the fetus, should not be given systemically during the first 12 weeks of pregnancy. Thereafter, it can be given with impunity despite the fact that it is known to cross the placenta. The drug is also excreted in the milk so it may be unwise to administer it to lactating women, unless absolutely necessary.

It is generally stated that metronidazole administered orally is excreted in only small amounts through the vaginal wall; so its efficacy is difficult to understand. The fact that the treatment is generally efficient after total hysterectomy rather rules out the possibility of a significant secretion by the endometrial and cervical glands. It has been suggested that the real nidus of infection is in the bladder and urethra and it is this which is eradicated by a renal excretion of the drug.

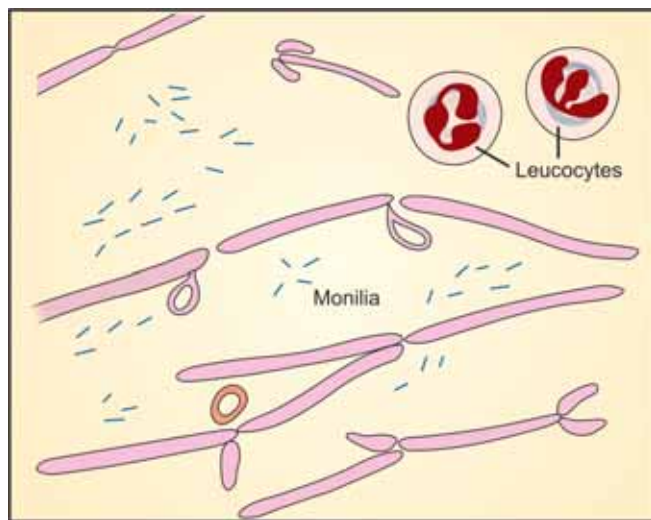
Oral medication with metronidazole is curative in 85-90 per cent of cases and the figure rises to 95 per cent if the patient's consort is treated simultaneously. Tinidazole and secnidazole 2 g as a single oral dose are also effective and have lesser side-effects.

Chronic trichomoniasis in old women sometimes proves resistant and, in such cases, treatment with the oral trichomonacide can with advantage be preceded by



or combined with oestrogen therapy as for senile vaginitis.

According to laboratory studies, *Trichomonas vaginalis* is never resistant to metronidazole but clinically, resistance is occasionally encountered. This is possibly because other bacteria in the vagina break down the drug and make it ineffective but, more often, it is due to faulty absorption from the alimentary tract. The last can be overcome by doubling the dose. Otherwise, another trichomonacidal drug, such as tinidazole or secnidazole, 2 g initially and 1 g daily for 6 days, can be substituted and again given to both sexual partners. Patients taking metronidazole or any of these drugs should be warned of the possible disulfiram (Antabuse)-like effect of these drugs in association with alcohol. Unless patients are warned, they quite logically give up the tablets rather than the alcohol. There is rarely any need for local treatment of *Trichomonas* vaginitis but this does arise during the first trimester of pregnancy, when oral medication has to be discontinued because of the possibilities of teratogenicity and vomiting or other side effects; and possibly in the handling of resistant cases. In such circumstances intravaginal medication with metronidazole or clotrimazole, 100 mg pessaries, one per night for 7 nights, has been found effective. Nonoxynol-9 and povidone-iodine are also trichomonacidal but these are not recommended for use in pregnancy.



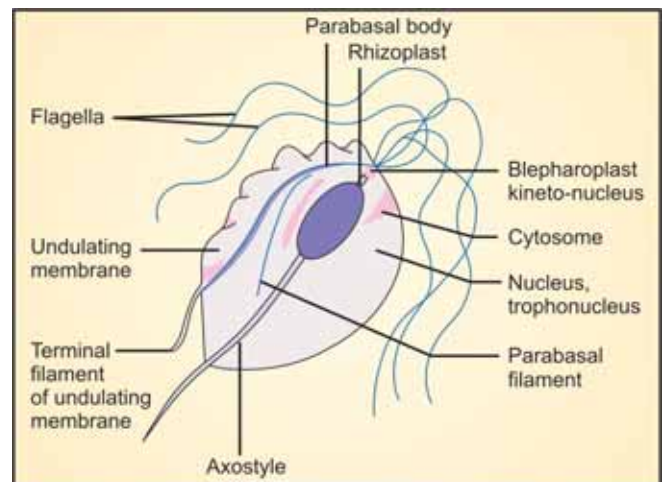
**Fig. 20.8:** *Candida albicans*, showing hyphae and spores. This preparation was made from cultures of vaginal discharge

## Candida Vaginitis

### Aetiology

This condition, also called vaginal *thrush*, is caused by the yeast-like organism *Candida albicans*, a small Gram-positive fungus which develops pseudomycelial threads with septate divisions and clusters of blastospores (Fig. 20.8). It thrives on carbohydrate and likes an acid medium (pH 4.0-5.5). This explains why the patient's symptoms are temporarily relieved by bathing or douching with 1 per cent sodium bicarbonate solution and during menstruation when the vagina is more alkaline.

*C. albicans* has a wide distribution in the body but is ordinarily nonpathogenic, being kept in check by bacteria. It can be demonstrated in the mouths of 25 per cent of all women, on the perianal skins of 8 per cent, and in the vaginas of 20-25 per cent. Most vaginal (as well as alimentary and systemic) infections probably represent a change from the carrier state determined by circumstances which favour the growth of the fungus at the expense of other organisms. *Candida* vaginitis is often determined by glycosuria because of the availability of carbohydrate. It occurs frequently during pregnancy because the vagina then contains much glycogen, glycosuria is common, and the high vaginal acidity tends to destroy other bacteria. The taking of oral



**Fig. 20.9:** *Trichomonas vaginalis*. The protozoa are seen only in a wet film and are of varying shapes. They may be adherent to a squamous cell or they may be attached to pus cells

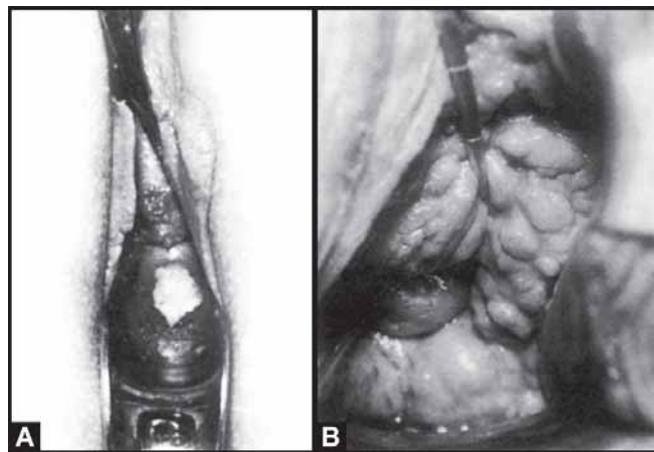
contraceptives favours the disease but, in nonpregnant women, the commonest cause is the taking of antibiotics, especially those covering a broad spectrum of bacteria. These, administered for incidental illnesses, alter the vaginal flora in favour of *Candida*. Indeed, the irresponsible use of these is mainly responsible for the present widespread manifestations of candidiasis in both sexes throughout all communities.

Vaginal infection can be associated with lesions elsewhere in the body—the alimentary tract, hands, feet and perianal skin—of the patient or of her consort. It can also be contracted during coitus with a man suffering from urethritis and balanitis, or so it is said. In fact, these conditions are so uncomfortable as to prohibit intercourse; it is the asymptomatic male carrier who is more likely to be responsible.

A combination of *Candida* and *Trichomonas* vaginitis is quite common, the dual infection again being possibly sexually transmitted.

#### Pathology and Clinical Features

The main symptoms are vaginal discharge associated with vaginal and vulvar pruritus, the latter often being out of all proportion to the amount of discharge. Local soreness causes dyspareunia. The discharge is typically thick, white and cheesy, tending to form plaques which are lightly adherent to the vaginal wall (Fig. 20.10A). They pull away to leave multiple haemorrhagic spots. In fact, the discharge is often atypical and may be watery or purulent while the vaginal walls and introitus can



**Figs 20.10A and B:** Two types of vaginitis. (A) *Candida* infection showing the classical patch of vaginal thrush, (B) Vaginitis emphysematosa occurring in midpregnancy

appear diffusely reddened, oedematous or reasonably normal.

A very rare complication of *Candida* vaginitis is wide dissemination of the parasites to produce a dangerous systemic infection.

#### Transfer of Infection

One of the features of vaginal candidiasis is that the husband may also complain of burning or itching of the external genitalia for a few days following each act of coitus. The only causes of this symptom are: *Candida* infection; *Trichomonas* infection; and allergy to the rubber or chemical constituents of contraceptives. This is a valuable point in diagnosis. The woman who harbours the organisms in the vagina in late pregnancy may also infect the baby during its birth. This may be the origin of candidal stomatitis (thrush) in the newborn.

#### Diagnosis

The diagnosis of pruritus with discharge nearly always means either *Candida* or *Trichomonas* infection. A wet mount or saline preparation of the vaginal discharge should routinely be done which can identify the presence of mycelia and yeast cells, and also exclude clue cells and trichomonads. A 10 per cent potassium hydroxide preparation is even more sensitive as it dissolves the red and white blood cells and improves visualization. If on direct microscopy large numbers of white cells are seen and the pH is greater than 4.5, mixed infection should be suspected. If WBC are absent and the pH is <4.5, antifungal treatment can be instituted. If direct microscopy does not show yeast cells or any other specific features, the vaginal swabs must be kept moistened with warm normal saline solution, transported to the laboratory and cultures using Sabouraud's broth or Nickerson's medium prepared for reliable results. Better still is the inoculation of a tube of Feinberg-Whittington medium beside the patient. This permits the detection of both *Candida* and *Trichomonas* in one specimen. Antifungal treatment can be started after submitting the cultures.

#### Treatment

Treatment with fungicides needs to be accompanied by controlling glycosuria, discontinuing oral contraceptives temporarily and eliminating any other aetiological factor. The one that cannot be removed is pregnancy and it can

be difficult to eradicate *Candida* completely from the vagina until after delivery. The pregnant as well as the nonpregnant woman, and their consorts if necessary, are treated by local applications of one of the many fungicides available.

Of these, the traditional gentian violet solution, used in the past, is now outmoded. Although effective it is messy and can cause severe local reactions with exfoliation of the superficial layers of the epithelium.

A wide variety of highly effective imidazole agents are now available which are effective against a wide variety of yeasts and fungi. Topical preparations are available as pessaries and creams, e.g. clotrimazole or miconazole 100 mg vaginal pessary to be inserted daily at bedtime for 6 nights or 2 tablets daily for 3 nights. Terconazole 80 mg vaginal suppository is inserted daily for 3 nights. Clotrimazole 500 mg vaginal tablet is administered in a single dose and produces adequate concentrations of the drug 5 days after insertion. Similarly ticonazole 300 mg is inserted once only.

Vaginal creams used with an applicator include 1 per cent clotrimazole or 2 per cent miconazole for 7 nights or 0.8 per cent terconazole or 2 per cent butoconazole for 3 nights. With topical azoles, mild to moderate burning can occur. Cure rates are in the range of 80-90 per cent.

Oral systemic imidazoles achieve comparable or marginally higher therapeutic cure rates. Ketoconazole 100-200 mg bd for 5 days, itraconazole 200 mg bd for 1 day or fluconazole 150 mg for 1 day have all been used. Longer term itraconazole has been used in more severe and resistant cases, 400 mg on the first day followed by 200 mg for 3 days. Oral agents are more convenient, less messy, but may have systemic toxicity, e.g. ketoconazole produces hepatotoxicity. Severe local symptoms may necessitate adjunctive topical treatment for the first 48 hours. A douche of 1 per cent sodium bicarbonate can relieve the pruritus. A combination of a topical steroid with an antifungal is beneficial if the vulva is significantly erythematous and inflamed. Single-dose therapy is effective in mild to moderate disease.

Severe vaginitis or recurrent disease should not be treated with single-dose therapy. Ketoconazole 100 mg daily, or once-weekly regimens of either 500 mg clotrimazole suppositories or 100 mg fluconazole orally have been used. The imidazoles are fungistatic agents and *non-albicans* strains of *Candida* may respond poorly.

Ticonazole demonstrates activity against *C. glabrata* and *C. tropicalis* in addition to *C. albicans* in *in vitro* studies. *C. albicans* strains have been reported to have become resistant to fluconazole.

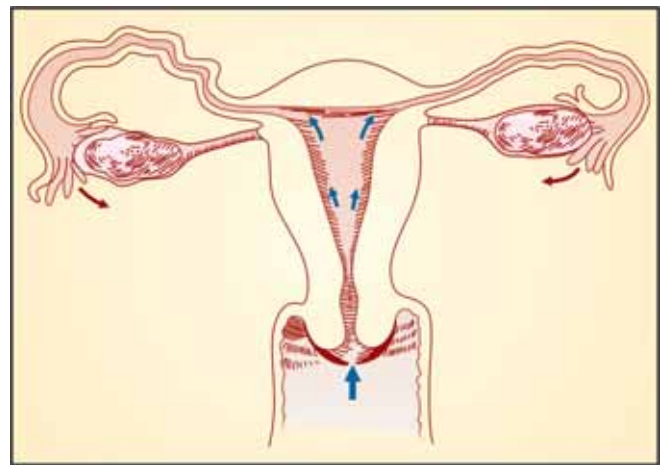
### Bacterial Vaginosis (BV)

Bacterial vaginosis is the commonest cause of vaginal discharge in the reproductive age group.

#### Pathology

*Gardnerella vaginalis* is the organism most commonly associated with BV. It is a small pleomorphic coccobacillus that may be Gram-variable when stained and is found attached to epithelial 'clue cells' in smears of vaginal exudate or discharge. It is considered to be sexually transmitted. Usually bacterial vaginosis results from ascending infections (Fig. 20.11).

Other microorganisms isolated from vaginal culture in BV include genital *Mycoplasma* and anaerobic bacteria such as *Peptostreptococci*, *Bacteroides* spp., *Prevotella* spp. and *Mobiluncus* spp. Lactobacilli are decreased or absent. The microbial ecosystem of the vagina is thus altered. Amines produced by the microbial flora, possibly by microbial decarboxylases, result in the characteristic fishy odour on mixing vaginal fluid with 10 per cent KOH ('whiff test').



**Fig. 20.11:** Micro-organisms originating in the endocervix ascend into the endometrium, fallopian tubes, and peritoneum, causing pelvic inflammatory disease (endometritis, salpingitis, peritonitis). (From Soper DE. Upper genital tract infections. In: Copeland LJ, ed. Textbook of gynecology. Philadelphia, PA: WB Saunders, 1993:521)

*Clinical Features*

The patients characteristically present with a homogenous, white, nonviscous, malodorous, uniformly adherent, vaginal discharge. The discharge may be profuse enough to be seen at the labia. When other infections like *Trichomonas* and *Candida* are associated, as they may be in 25 per cent of cases, the picture may be modified. Some patients may be asymptomatic. IUCD use predisposes to BV.

BV has been implicated in postpartum endometritis, in posthysterectomy vaginal cuff cellulitis and in postabortion pelvic inflammatory disease.

*Diagnosis*

BV is diagnosed when at least three of the following are present: characteristic homogenous white adherent discharge; positive 'whiff test'; vaginal fluid pH >4.5; clue cells representing at least 20 per cent of the vaginal epithelial cells. The presence of clue cells is the most important criterion for diagnosis: A wet mount examination shows squamous epithelial cells covered with multiple bacteria, which gives the cells a stippled look with obscured borders (Figs 20.12A and B). Vaginal cultures are not as useful as *G. vaginalis* may be isolated even in the absence of BV. For the same reason, vaginal cultures cannot be used as a test of cure.

*Treatment*

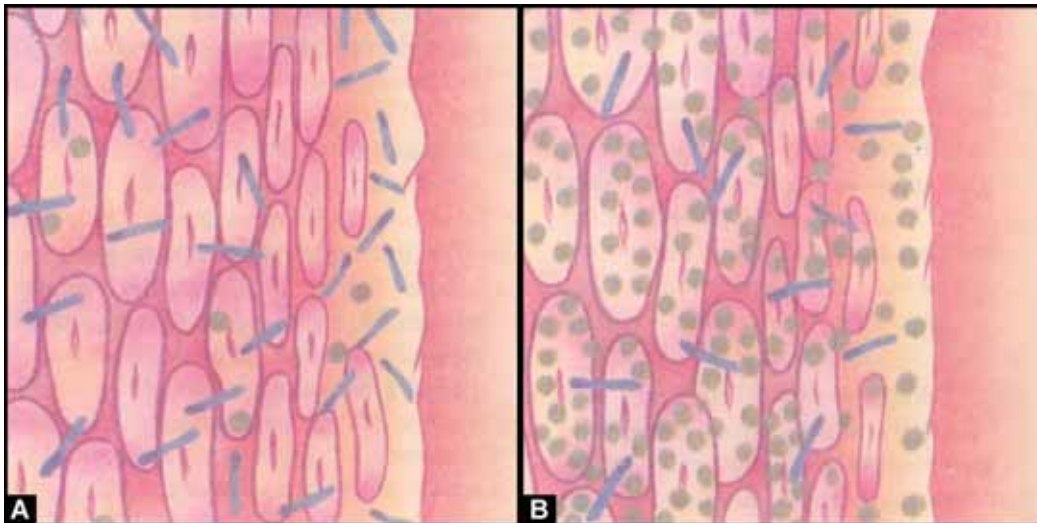
Metronidazole 400 mg thrice daily for 5-7 days results in 80 per cent cure rates. Intravaginal metronidazole has fewer side effects but lowers the cure rates. Oral clindamycin 300 mg twice daily for 7 days is as effective as oral metronidazole and is preferred in pregnancy. Treatment of the male partner does not improve the clinical outcome. Vaginal acidifiers may suppress but do not kill anaerobic organisms and alternative treatments like lactobacillus, yoghurt and disinfection have limited use in the treatment of BV.

*Oral Probiotic Therapy with Lactobacillus*

It has been seen that lactobacilli taken orally will pass through the G.I. tract and are seen to colonise the vagina via migration over the perineum.

**Other Vaginal Infections**

Some rare causes of vaginitis are the gonococcus and pneumococcus which are seen mainly in children. Infections due to diphtheria, *Salmonella typhi* and *paratyphi* are also very rarely seen. The term puerperal vaginitis is sometimes used to cover infection of vaginal lacerations sustained during childbirth.



**Figs 20.12A and B:** (A) Normal mature vaginal cells. The bacterial flora is dominated by lactobacteria (rod-shaped), and (B) the field dominated by "Clue cells". Few lactobacilli are also seen

### Vaginitis Emphysematosa (Colpitis Cystica)

This is an uncommon but extraordinary condition, most of the recorded cases having been in pregnant women. It is characterised by numerous small bullae in the vaginal epithelium which are filled with a gas (Fig. 20.10B). The surrounding tissues are hard and indurated and give the impression of advanced malignant disease. The symptom is a profuse purulent discharge.

The nature of the gas in the tissue spaces is almost certainly carbon dioxide. The cause of vaginitis emphysematosa is disputed but, in the great majority of cases, trichomonads can be found in the vagina. These parasites, possibly by unusually deep penetration of the vaginal wall, are the most likely agents. *Gardnerella vaginalis* is also blamed.

The disease can cure itself spontaneously within a few weeks or months, often before the pregnancy is over. On the evidence, it should respond to treatment with metronidazole, although prior to the introduction of the drug the cysts often regressed spontaneously.

### Non-infective Vaginitis

#### Traumatic

Infection and ulceration can be the result of *foreign bodies* placed in the vagina (see Chapter 15), and can complicate the anatomical and vascular changes which accompany uterovaginal *prolapse*. Occasionally, severe and recurrent vaginitis with ulceration is caused by *self-inflicted trauma*, prompted possibly by sexual perversion or other psychological upsets. This cause can be difficult to prove.

#### Burns

Discussed elsewhere.

#### Allergy; Drug Sensitivity

A local reaction to chemicals is not uncommon and the patient presents with discharge, pruritus and a fiery red vagina. Antiseptics such as arsenic, mercury, iodine, picric acid, phenol preparations and gentian violet used to be common causes. Presently, toilet preparations such as soaps, deodorants and bath salts; contraceptives such as rubber or materials used in the preparation of synthetic devices, the powder in which they are packed and chemical spermicides; and nylon underwear are the common causes.

The diagnosis is made by careful enquiry about the onset of symptoms, bearing in mind the possibility of skin sensitivity. The treatment consists of removing the cause and arranging for saline douches and warm baths. Antihistamines by mouth and local applications of hydrocortisone may also relieve symptoms.

The reaction not uncommonly includes cystitis and urethritis.

#### Idiopathic

There are some isolated cases of troublesome, chronic and resistant vaginal ulceration, sometimes multifocal, the causes of which are never discovered. These have been treated empirically by vitamins, antihistamines, antiseptics, various fungicides and trichomonocides and, in the case of postmenopausal women, with oestrogens.

### CERVICITIS

Infection of the stratified squamous covering of the vaginal cervix as part of vaginitis is not usually regarded as cervicitis; this is a term reserved for inflammatory lesions in the endocervix including the glands and deeper tissues.

#### Acute Cervicitis

This is mainly gonococcal, chlamydial or puerperal in origin and the lesion is relatively unimportant in itself, the symptoms and physical signs being overshadowed by those caused by simultaneous infection of other tissues. Organisms gain entry through the gland openings in the endocervix, and through obstetrical and surgical injuries.

The cervix is congested and enlarged with a swollen mucous membrane protruding at the external os. It is tender when touched or moved, and a profuse purulent discharge exudes from the cervical canal.

Acute cervicitis may resolve completely or progress to a state of chronic cervicitis. Its treatment is that of the more widespread infection of which it is merely a part.

#### Chronic Cervicitis

##### Aetiology

Chronic cervicitis is variously estimated to be present in some degree in 35-85 per cent of women. It can probably arise as a result of vaginal organisms becoming

pathogenic; it occasionally follows chronic and repeated injury from pessaries, tampons and unsatisfactory contraceptive devices; it may be gonococcal but is usually the end result of puerperal cervicitis. The puerperal type is often associated with laceration of the cervix and with chronic cellulitis.

### Pathology

Although organisms can linger in the glands of the endocervix for many years, the condition of chronic cervicitis does not usually represent an active inflammatory state. It is the end result of injury and inflammation. The mucosa and deeper tissues are fibrosed, congested, and infiltrated with leucocytes and plasma cells. There may also be hypertrophy of glandular tissue to produce what was previously described as an *adenomatous cervix*. The ducts of certain glands become obstructed by plugs of epithelial cells and inspissated mucus, or by fibrosis, to cause retention cysts — *Nabothian follicles*. These are often visible to the naked eye and can become quite large (Fig. 20.13).

A relationship between chronic cervicitis and the development of cervical cancer, once postulated, is no longer acceptable; and chronic cervicitis is *not* a cause of erosion as was once believed, and still is in some quarters.

### Clinical Features

Chronic cervicitis is usually a histological diagnosis without clinical significance. Some evidence of it is found in nearly all multiparous, and many nulliparous, cervixes submitted to histological examination. Only when the

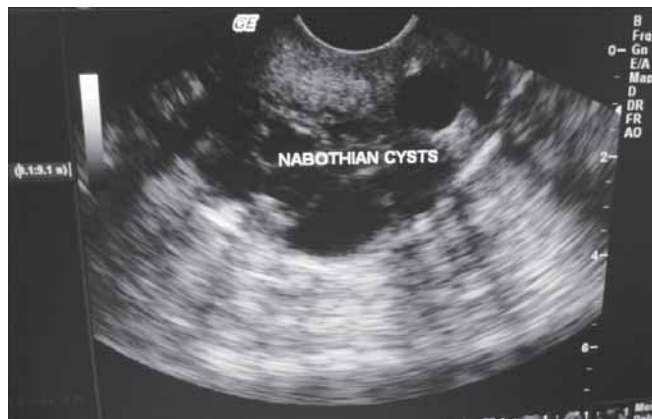


Fig. 20.13: Retention cysts (Nabothian follicles) in the cervix

injury and reaction are very severe do they cause symptoms, and all these, with the exception of discharge, mostly derive from an associated cellulitis. They tend to be worse premenstrually and include: mucopurulent discharge — the mucus is due to overactivity of the glands themselves; low backache which is only partly relieved by rest; aching in the lower abdomen and pelvis; deep-seated dyspareunia; contact bleeding; menorrhagia and congestive dysmenorrhoea possibly from associated endometritis; and infertility, alleged to result from changes in the physical characters of the cervical plug, from a decreased pH of the cervical canal and from an increased pH of the vagina — a profuse discharge can raise the vaginal pH to 5–7.5. The last symptom is questionable and certainly many women with gross chronic cervicitis conceive without difficulty.

All manner of other conditions and symptoms have been ascribed to chronic cervicitis — arthritis, dyspepsia, pain on defecation and bladder irritability. Indeed, cauterization or other treatment of an allegedly infected cervix has been claimed to cure nearly all the ills to which the woman is subject. It should therefore be emphasized that *the only symptom* clearly attributable to cervicitis *per se* is discharge and this usually dates from an attack of infection, from abortion or from labour.

### Diagnosis

The physical signs in the cervix which may lead to the diagnosis are: enlargement and congestion; ectropion; cystic glands; pouting and florid endocervix; fixation; tenderness to the touch; and pain when the cervix is moved or pierced with a volsellum. It can be difficult to distinguish chronic cervicitis from carcinoma and this may be impossible sometimes without biopsy. Vaginal cytology and colposcopy aid the diagnosis of malignancy (*see* Chapter 25). The exclusion of malignancy is especially important before using ablative methods of therapy.

### Treatment

#### Antiseptics

Since any infection is always deep seated, the superficial application of antiseptics by means of pessaries or paints is useless. Douching has only the merit of removing discharge and odour temporarily, but it may introduce

the discharge into the upper genital tract and is no longer recommended.

### *Antibiotics*

Antibiotics are useful only in case of active infection, e.g. gonorrhoea or chlamydia.

### *Cauterization, Cryotherapy or Laser Ablation*

Chemical caustics employed in the past are of little value and have been replaced by electric or diathermy cauterization, or cryotherapy, to destroy diseased areas.

By cautery, cystic glands are punctured, ectropion corrected by deep linear burns, and any coincidental erosion coagulated. The cervical canal is treated only with caution or left alone.

Cryotherapy is preferable to cautery. It is done using the probe which best fits the lesion and the entire lesion is frozen (*see* page 420).

Laser ablation, e.g. with the CO<sub>2</sub> laser, has the advantage of cure rates similar to cryotherapy but with the transformation zone maintained in its normal position. Following cryotherapy it usually recedes into the endocervical canal and is not visible for further evaluation if required.

These forms of treatment are office or outpatient procedures; general or even local anaesthesia is seldom required.

Following treatment, a slough separates in approximately 10 days. This is attended by an increase in discharge and often by frank bleeding. Following cryotherapy and laser the discharge is extremely profuse and the patient should be advised replacement of electrolytes to avoid feeling very weak. Thereafter, the discharge slowly subsides in 4-6 weeks, which is the time taken for squamous epithelium to grow over the raw area.

The late sequelae of overenthusiastic cauterization are: obstruction of the ducts to cause more cystic glands and cervical stenosis.

### *Trachelorrhaphy*

The edges of lacerations can be excised and the cervix reconstituted by a plastic operation.

### *Hysterectomy*

If the condition of cervicitis is so severe that it cannot be treated satisfactorily with diathermy, cryotherapy or

cone excision, and future fertility is not desired, hysterectomy is sometimes indicated.

### Special Forms of Cervicitis

Tuberculosis, syphilis, schistosomiasis, amoebiasis and other special infections and ulcers of the cervix have already been described along with vaginitis and in Chapter 19.

## ENDOMETRITIS

### Acute Endometritis

Apart from infections introduced at operations and by instrumentation, acute endometritis is either gonococcal or puerperal in type.

### Chronic Endometritis

#### *Aetiology*

In theory, every case of acute endometritis might go on to chronic endometritis. In fact, the regrowth of new surface endometrium during each menstrual cycle prevents the persistence of any infection which is not deep seated. Chronic endometritis is therefore a rare disease between the menarche and the menopause, and only occurs when the uterus is permanently injured, or when there is opportunity for it to be continually reinfected. Its causes are: foreign bodies within the uterus; malignant disease of the uterus; infected polyps; retained products of conception; with inflammatory cells, including altered macrophages known as 'foam cells'. Its lining epithelium becomes destroyed and converted into granulation tissue. This exudes pus, which tends to collect in the uterus to form a *pyometra* because the cervix is narrowed by senile change and because the atrophied myometrium is unable to expel it. The uterus enlarges by thinning its walls and spontaneous rupture followed by peritonitis is described as a rare complication.

Sometimes, in response to pyometra, the endometrial epithelium undergoes metaplasia into a stratified squamous type. Senile endometritis is a condition associated with cancer. The ultimate growth is usually an adenocarcinoma but can contain squamous cell elements.

#### *Clinical Features*

A purulent and very offensive postmenopausal discharge, sometimes bloodstained, is the main

complaint. When a pyometra forms, the discharge occurs intermittently, ceasing for a few days or weeks and then returning immediately after colicky lower abdominal pain. The uterus generally feels small and atrophic but, in the case of pyometra, may be enlarged, soft and cystic.

### Diagnosis

The clinical features are identical with those of carcinoma of the body of the uterus so the diagnosis of senile endometritis can only be made by curettage. If a pyometra is present, pus escapes as the cervix is dilated and conventional curettage then involves the risk of spreading the infection to cause cellulitis and peritonitis. To avoid this, curettage may have to be deferred for 1 or 2 weeks but must be carried out sooner or later if carcinoma is to be excluded. When it is done, a cover of antibiotics is desirable. Some form of suction curettage or endometrial lavage is less hazardous.

### Treatment

The drainage of the uterus afforded by dilatation of the cervix is enough to cure some cases. There is, however, much to be said for hysterectomy in all cases of senile endometritis if the patient is reasonably fit. This not only makes for certain cure; it circumvents the difficulty of excluding the presence of an underlying carcinoma and removes a potentially malignant organ.

## Pyometra (Pyohaematometra)

The collection of pus, or of a mixture of pus and blood, within the uterus is described in this and other chapters. It is convenient here to summarize the possible causes which are: congenital atresia of the vagina or cervix; stenosis of the cervix or vagina following operations, burns and radiotherapy; puerperal endometritis with retention of the lochia; tuberculous endometritis; senile endometritis; carcinoma cervix; and carcinoma corporis. The commonest of these are malignant states of the uterus, acting alone or in association with radiotherapy; after these, senile endometritis. Benign tumours of the uterus, even infected polyps, rarely if ever cause pyometra because they do not obstruct the cervix.

## METRITIS

### Aetiology

The myometrium may be involved as part of a widespread pelvic infection but metritis is rarely an

entity in itself. Some degree of acute metritis is present in all cases of spreading puerperal endometritis. In prolonged labour with devitalization of the lower segment, and in certain cases of abortion complicated by *Clostridium welchii* infection or induced by the injection of chemical irritants, the uterine wall becomes gangrenous (Fig. 20.14). Curettage in the presence of endometrial infection can also cause metritis.

### Pathology

The myometrium shows the usual reaction to infection — congestion and inflammatory cell infiltration in its early stages, and possibly fibrosis ultimately. There may even be abscess formation (Fig. 25.8).

### Clinical Features

These are obscured by those of other inflammatory lesions which are always present. An abscess causes intermittent pyrexia and possibly pyaemia.

## SALPINGO-OOPHORITIS

When the fallopian tubes are infected the ovaries are usually affected as well, although often to a minor extent. The term salpingitis should therefore generally be taken as meaning salpingo-oophoritis. Salpingo-oophoritis is nearly always bilateral (unless one adnexum has been removed) and is essentially a disease of the young adult.

### Aetiology

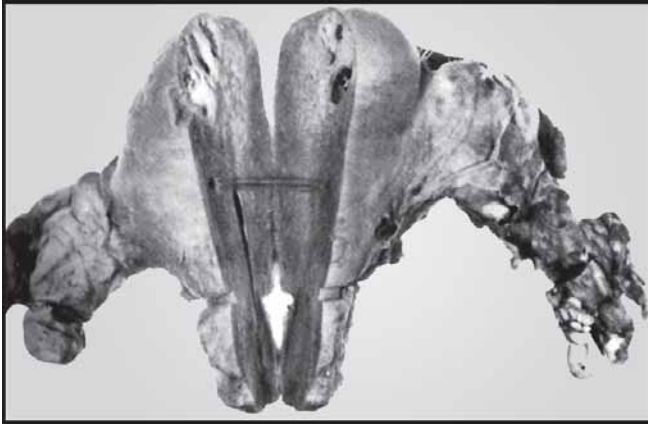
#### Ascending Infection

Acute salpingitis is a polymicrobial infection. In gonorrhoea and chlamydial infection, the organisms ascend through the uterus and along the tube to produce an endosalpingitis. Other organisms like *Gardnerella vaginalis*, *Bacteroides* spp. especially *B. fragilis*, *Peptostreptococci*, *Proteus* and *Klebsiella* spp. may also originate from the vagina.

#### Puerperal and Postabortal

The organisms concerned in puerperal infections are usually streptococci, staphylococci, *Escherichia coli*, the genital mycoplasmas and *C. trachomatis*. They spread from the uterus by lymphatics and veins to the peritoneum to cause pelvic peritonitis. The adnexa are only involved as part of the pelvic peritonitis and this explains why the old term for this condition was





**Fig. 20.14:** Chronic abscesses in the uterine wall associated with chronic salpingo-oophoritis and pelvic cellulitis. This condition arose as a result of puerperal infection and caused death of the patient from pyaemia several weeks after delivery

*perimetritis*. Although intraluminal spread of infection occurs to a limited extent, the tube is attacked mainly from the outside (Fig. 19.1).

#### *Tuberculous*

Elsewhere discussed.

#### *Other Infections*

Rarely, the tubes are involved in actinomycosis, schistosomiasis and other special infections described elsewhere.

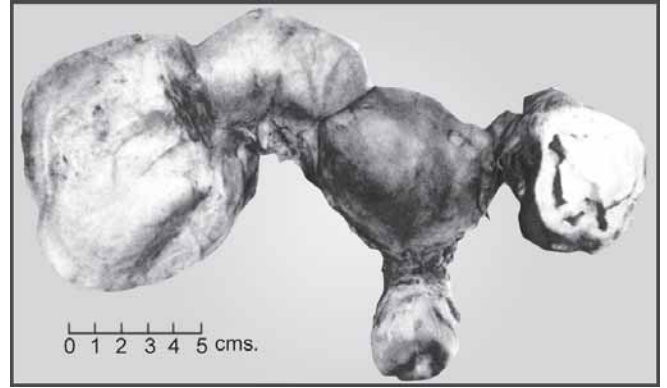
#### *Pyogenic Infection of Pelvic Peritoneum*

The tubes and ovaries become involved in any state of pelvic peritonitis. Often the primary cause is in the alimentary tract (appendicitis and diverticulitis, for example) and the infection is a mixed one with the coliform organisms and Gram-negative *Enterobacteriaceae* being predominant.

Whatever the nature of the original infection, secondary invaders from the bowel are common. These or the primary organisms show periodic phases of activity, so salpingo-oophoritis tends to be a recurrent disease. In the case of gonorrhoea, however, repeated attacks probably always represent reinfection.

#### **Pathology**

Ordinarily the endosalpinx is affected along its whole length but the gonococcus shows a predilection for the



**Fig. 20.15:** Bilateral tubo-ovarian abscesses, probably gonococcal in origin

outer part to leave permanent damage of a characteristic type.

In the acute phase of any infection the tissues become reddened and oedematous showing, on microscopic examination, the usual inflammatory responses. Thereafter the following developments are possible.

#### *Resolution*

The tubes and ovaries can return to normal structure and function if the infection does not cause appreciable tissue destruction.

#### *Abscess Formation*

If the endosalpinx is destroyed in part or whole and converted into granulation tissue, pus is formed. This can escape into the peritoneal cavity or be retained within the tube depending on whether and when the abdominal ostium becomes closed. So it may collect in the tube to result in a *pyosalpinx*, in the ovary to form an *ovarian abscess*, in both to produce a *tubo-ovarian abscess* (Fig. 20.15), or in the pouch of Douglas to cause a *pelvic abscess*. The walls of a chronic pyosalpinx (Fig. 20.16) can ultimately become calcified, although such a happening generally betokens a tuberculous basis.

#### *Healing by Fibrosis*

When this happens, the tube wall thickens in part or whole; the plicae adhere together to obstruct or distort the lumen; and the tube and ovary become adherent to adjacent organs, to the broad ligament and to the uterorectal pouch. The parts of the tube most likely to be obstructed are the abdominal ostium and the narrow

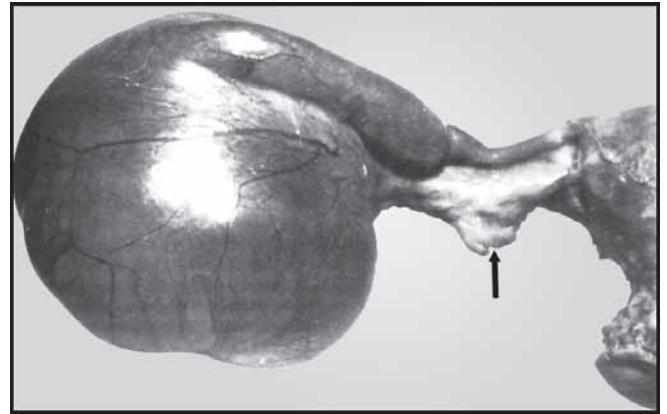


**Fig. 20.16:** Pyosalpinx 3D ultrasound

isthmus. In the latter site, chronic infection causes beading and thickening which give rise to the name *salpingitis isthmica nodosa*. This old term describes nodular lesions felt in the tube and of uncertain cause. Some use the term for tuberculous infection although the nodules may be caused by either an endosalpingitis or a perisalpingitis.

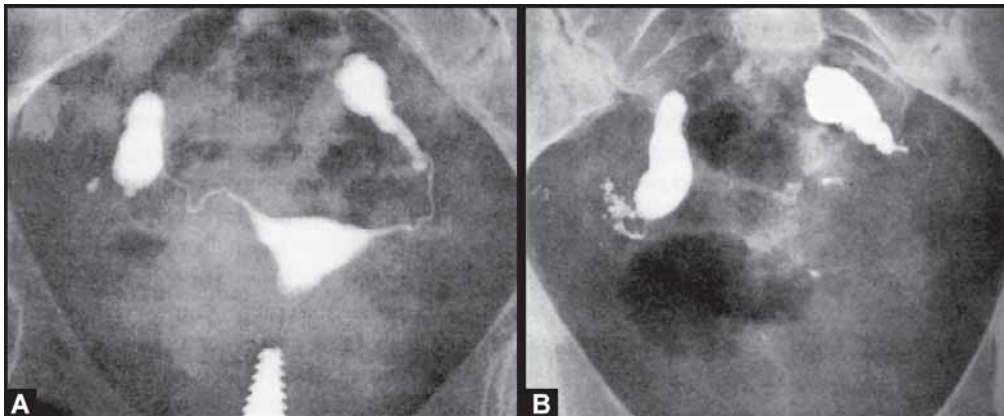
### Hydrosalpinx

When the inflammation subsides to leave the fimbrial end sealed, but the tubal epithelium elsewhere intact, the natural secretions cannot escape and the tube gradually distends with watery fluid to become a *hydrosalpinx*. This is a retort-shaped swelling which only



**Fig. 20.17:** Hydrosalpinx. The retort-shaped enlargement of tube with closure of the outer end. Disappearance of the fimbria and absence of adhesions is typical and suggests a previous gonococcal infection. The ovary (indicated by an arrow) is separate from the tumour

exceeds the size of an orange in exceptional cases (Fig. 20.17). An extraordinary feature of a hydro-salpinx is that the inner end of the tube is nearly always open and yet the fluid does not drain into the uterus. Perhaps the tubal muscle is so damaged or stretched that it cannot expel the fluid; perhaps the tube normally drains into the peritoneal cavity rather than into the uterus. Examination of specimens suggests that the phenomenon is not explained by a valve mechanism at the uterine end. This feature is fortunate in that it enables the diagnosis to be made by hysterosalpingography (Figs 20.18A and B). An uncomplicated hydrosalpinx is



**Figs 20.18A and B:** Bilateral hydrosalpinges, revealed by salpingography, in a woman aged 24 years who complained of infertility. She gave a history of gonorrhoea and of one abortion prior to marriage but this condition is much more likely to be the result of gonococcal salpingitis than of postabortal infection, (A) Radiograph taken immediately after the injection of an oily radio-opaque material. The appearance of the globules in the dilated outer end of the left tube represents a failure of the oil to mix with the watery contents of the tube, (B) Twenty-four hours later the medium remains loculated in the hydrosalpinges

usually too soft and flaccid to be palpable on bimanual examination. With high resolution transvaginal ultrasound and 3D, the diagnosis of hydrosalpinx can also be made. Classical ultrasound findings are elongated cystic mass with incomplete septations (Fig. 20.19).

The pathogenesis of hydrosalpinx is not agreed. It has been suggested that it represents the end result of pyosalpinx — the pus having liquefied. Bearing in mind the comparatively thick walls of a pyosalpinx and the destruction of the endosalpinx which goes with it, it is difficult to believe that the thin-walled hydrosalpinx lined by normal although compressed endosalpinx can ever be its offspring. The outlook as far as fertility is concerned is unfavourable, for although the endothelium is able to secrete it is functionally impaired. Moreover, when a hydrosalpinx is found, there is usually no history of a severe previous infection; often there is no history of salpingitis sufficient to cause symptoms. Nevertheless, the most likely cause of this condition is a gonococcal infection whose aftereffects are limited to the ampullary area of the tube, one which produced few or no clinical manifestations when it happened. The apparent absence of fimbriae strongly supports this concept.

Other possible backgrounds when there is no history of previous disease, are previously unrecognised subclinical infections related to *Chlamydia* and other

organisms, perhaps even including gonococcal or tubercular infections. In tuberculosis, however, the appearances are very variable depending on the site and mechanism of infection.

#### *Tubo-ovarian Mass*

When a hydrosalpinx is adherent to an ovary containing one or more follicular cysts, the two conditions give the appearance of a single multilocular structure. Sometimes the dividing wall breaks down but, even if it does not, the lesion is called a *tubo-ovarian mass*. In Western countries, tubo-ovarian masses rarely exceed the size of a fetal head. In the Far East, however, they commonly develop to the size of a pregnancy at term and are difficult to distinguish from large ovarian neoplasms.

#### *Peritoneal Cysts and Pseudocysts*

These not uncommonly result from adhesions following perimetritis. When such a cyst lies outside the ovary and has a wall formed by intestines and omentum, it is sometimes called a *pseudocyst*.

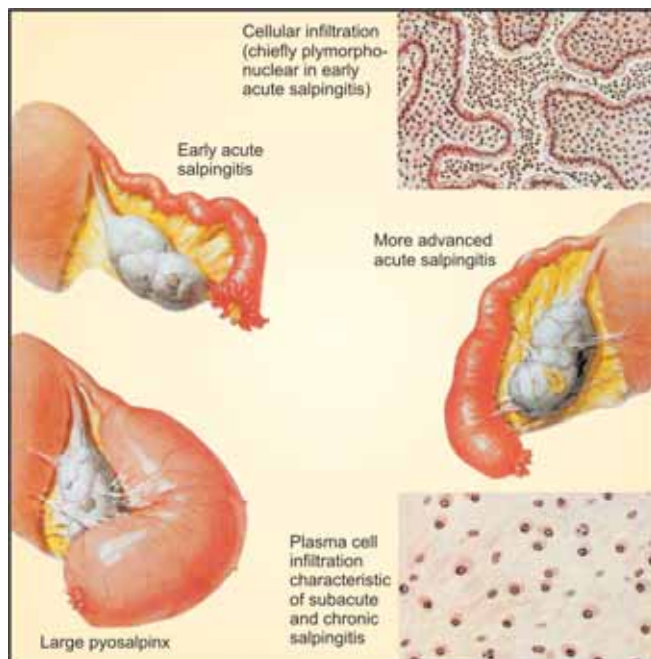
#### *Puerperal and Postabortal Infection*

This, being essentially an exosalpingitis, results in peritubal and periovarian adhesions with thickening of the tube wall and ovarian capsule. Pyosalpinx and hydrosalpinx are not common and, when the adhesions are separated, the fimbriae are found in a reasonably healthy state; even the tube lumen may be patent and lined by normal epithelium. Infections arising from the alimentary tract also have a similar effect.

### Clinical Features

#### *Acute salpingo-oophoritis*

This is a disease seen mainly in sexually active women of the reproductive age group. The clinical features mainly reflect pelvic peritonitis. The illness begins with acute lower abdominal pain, pyrexia, tachycardia, malaise and sometimes vomiting. The pain is situated diffusely across the lower abdomen or in *both* iliac fossae. A menstrual period may be delayed in onset by a few days or be precipitated early and it is often heavy and prolonged. There may be symptoms of urethritis as well. There is often a history of recent confinement or abortion, of a discharge suggesting gonorrhoea, of exposure to risk of infection, or of previous attacks of salpingitis.



**Fig. 20.19:** Hydrosalpinx and pyosalpinx

Symptom-producing salpingitis hardly ever occurs *during* pregnancy. After the first 12 weeks, the decidua vera and decidua capsularis fuse and a new infection cannot ascend through the uterus, while a preexisting chronic infection may have caused tubal damage. Cases of acute salpingo-oophoritis in pregnancy are rare, except when secondary to acute appendicitis. Similarly it is rarely seen in premenarchal girls or post-menopausal women. Women on oral contraceptive pills are also at a lesser risk, possibly because of the thickening of the cervical mucus plug.

The patient looks flushed and toxic and has a dirty mouth. The lower abdomen is tender with some muscle guarding. There may be obvious signs of lower genital tract infection but, on bimanual examination, it is often impossible to define either the uterus or the adnexa because of generalised tenderness. In any case the adnexa are not usually enlarged at this stage. A valuable test is to rock the cervix gently from side to side. This puts tension on the broad ligaments and adnexa and produces pain if salpingitis is present. There is a brisk polymorphonuclear leucocytosis and a raised erythrocyte sedimentation rate.

With spreading peritonitis, intestinal distension and constipation are likely; a pelvic abscess causes a swinging temperature, diarrhoea, pain on defaecation and sometimes retention of urine. A very serious complication is rupture of a pyosalpinx which causes an 'acute abdomen' and sometimes extreme shock. Bacteraemic shock in its severest form may complicate gonococcal salpingitis.

Acute salpingo-oophoritis has to be distinguished from the following:

- *Acute appendicitis*: In this, the pain commences higher in the abdomen and becomes unilateral; anorexia and vomiting are more likely; muscle rigidity is localised and more obvious; menstrual disturbance and discharge are absent.
- *Ectopic pregnancy*: Here the pain is mainly unilateral and causes collapse or fainting. There is little, if any, pyrexia and the leucocyte count is only slightly increased.
- Torsion of the pedicle of a leiomyoma or ovarian cyst
- Rupture of an ovarian cyst
- Rupture of an endometriotic cyst
- Ovulation pain and corpus luteum haematoma
- Diverticulitis
- Intestinal obstruction

- Pyelitis and cystitis
- Other causes of an 'acute abdomen'.

#### *Subacute Salpingo-oophoritis*

The onset of salpingo-oophoritis does not always produce the dramatic picture painted above. More often the disease is subacute from the beginning and can persist in this form for several weeks. The symptoms and signs are then less striking and the patient may be only moderately incapacitated, with less discomfort, less pyrexia and less pelvic tenderness. The clinical features in general are intermediate between those described above and those below.

#### *Chronic Salpingo-oophoritis*

Chronic salpingo-oophoritis may follow an acute or subacute stage but, in the case of certain causal organisms, the disease is chronic from the outset. Also, a previous acute infection may have been subclinical and have passed unnoticed. Chronic salpingo-oophoritis is mostly asymptomatic and often is only discovered by the finding of obstructed tubes during the investigation of infertility or during surgery for ectopic pregnancy.

Otherwise, the symptoms are chronic aching in the lower abdomen or in both iliac fossae, and sometimes in the lumbosacral region. The pain tends to be worse during the week preceding menstruation, and to ease gradually as congestion subsides during menstruation. Ovarian involvement results in more frequent periods, and uterine congestion to increased loss; so the complaint is of heavy and frequent periods. Except when the infection is tuberculous in type, amenorrhoea *never* occurs, even when there are bilateral ovarian abscesses. There is often a mucoid or mucopurulent vaginal discharge intermenstrually. Deep-seated dyspareunia and involuntary infertility are other common complaints; rectal discomfort and bladder irritability are seen occasionally. General health is affected by way of malaise, anorexia, lethargy, increased irritability and sometimes loss of weight.

Examination may disclose no abnormality. On the other hand, bimanual palpation may reveal generalised tenderness and fixation of the pelvic organs. According to their pathology the adnexa may be palpably enlarged. Often they feel nodular and hard. A fixed retroversion of the uterus and some degree of cellulitis in the uterosacral or broad ligaments are common findings.

Chronic salpingo-oophoritis has to be distinguished from the following:

- Ectopic pregnancy
- Appendicitis, diverticulitis and other diseases of the bowel, especially if adhesions have occurred
- Ovarian tumours, especially bilateral ones
- Pelvic endometriosis
- Congestive dysmenorrhoea and premenstrual syndrome
- Colonic and rectal spasm — irritable bowel and distended caecum syndromes.

### Treatment of Acute Salpingo-oophoritis

The treatment of acute salpingo-oophoritis is always conservative in the first place, hence the importance of distinguishing this disease from abdominal conditions requiring emergency surgery. Treatment should be preceded by taking cervical, rectal and urethral swabs to determine the nature of the infection.

#### *General*

Admission to hospital maybe required. It ensures adequate rest, constant observation and efficient treatment. Once the diagnosis is made, all local interference such as pelvic examination should be avoided. Even if she is not kept in bed continually the patient's physical activity should be severely restricted until her temperature and pulse rate have been normal for at least 5 days.

#### *Relief of Pain*

Warmth to the lower abdomen is soothing and, once the diagnosis is reasonably sure, pain should be relieved by analgesics, anti-inflammatory agents or even opiates.

#### *Antibiotics*

These are given in full dosage as for gonorrhoea, *Chlamydia* or postabortal infection.

#### *Surgical Treatment*

This is only indicated in the following circumstances: when there is evidence of spreading peritonitis despite adequate medical treatment; rupture of a pyosalpinx or ovarian abscess; intestinal obstruction resulting from adhesions; pelvic abscess formation; if the diagnosis is in reasonable doubt; if it is difficult to be sure that the condition is not one of acute appendicitis or other lesion

requiring urgent surgery. Laparoscopy is sometimes suggested in the acute phase if the diagnosis is uncertain but if there is any real possibility of peritonitis and adhesion formation, laparotomy may be safer. In cases of salpingitis, laparoscopy will reveal tubal hyperaemia and oedema, sticky exudates on the tubal surface and/or pus pouring out of the tubal ostia. It is generally wise to leave the pelvic organs untouched, except for taking a swab from any pus for bacteriological analysis, and, even if laparotomy has been performed, to close the abdomen without drainage. It is amazing how apparently hopeless tubes can recover to the extent of being functional. When there are large pyosalpinges, they are sometimes best removed - even in the acute phase.

### Treatment of Subacute and Chronic Salpingo-oophoritis

Before initiating treatment it is again important to investigate bacteriologically for the source of infection. When the disease is chronic, however, and excepting tuberculosis or other rare special infection, it is unlikely that a significant organism will be found. Tests may need to be repeated several times before the organism is isolated.

#### *Conservative Treatment*

An important part of treatment is a period of physical rest. Appropriate antibiotic therapy is indicated for the subacute disease but rarely helps if the salpingitis is truly chronic and consisting of little more than residual damage resulting from previous infection. Pelvic heat applied by means of hot water bottles 4 hourly, or by shortwave therapy, is comforting and sometimes appears to assist resolution of a subacute inflammatory reaction.

As swelling and fixation of the adnexa subside, as the uterus becomes more mobile, and when the temperature and pulse rate have remained normal for several days, the patient is allowed to resume activity gradually. Coitus should be forbidden until it is reasonably certain that the inflammatory process is completely inactive.

#### *Surgical Treatment*

##### *Indications*

- For persistence of symptoms despite trial of conservative measures

- For recurrent attacks or exacerbations of the disease
- For fixed retroversion
- For persistence of gross enlargement of the adnexa
- Sometimes for infertility
- Surgery is only really safe and likely to give the best results if it is carried out during a quiet phase, that is when: the temperature has been normal for at least 2 weeks; there is no rise in pulse rate or temperature after a test vaginal examination; the white cell count is normal; and the erythrocyte sedimentation rate is normal.

### Nature of Operation

This necessarily depends on the findings at laparoscopy or laparotomy. For infertility the object is to try to restore tubal function by *salpingolysis*, *salpingostomy* or *reimplantation of the tube* into the uterus. Even if reproductive function has to be sacrificed, menstrual function should be preserved, if possible, in young women; ovarian function, in particular, should be preserved, because of the possibility of *in vitro* fertilisation at a later date. The disadvantages are that sometimes the ovaries later become cystic, and the patient may be left with menorrhagia for which hysterectomy ultimately becomes necessary.

In the case of salpingectomy with conservation of the uterus, it is important to excise the cornu of the uterus which contains the intramural portion of the tube. This maybe infected and, if it is not removed, it can be the source of further symptoms.

For widespread chronic pelvic infection with disorganisation of both adnexa, total hysterectomy with removal of both tubes (and sometimes both ovaries) is often the best treatment. Indeed, this is often the eventual outcome after previous conservative surgery.

## OOPHORITIS

Oophoritis *without* salpingitis is rare and only occurs as a result of blood- or lymph-borne infection from elsewhere.

### Aetiology

Oophoritis occurs as a complication of septicaemia, typhoid and paratyphoid fevers, pneumonia and viral diseases such as mumps and influenza. Of these the commonest is mumps, the oophoritis being the equivalent of the orchitis complicating parotitis in the male.

Tuberculosis, sarcoidosis, syphilis and actinomycosis are very occasional causes.

### Pathology

The acute inflammatory reaction nearly always subsides completely without permanent ill effect. However, abscess formation or healing with fibrosis and fibrocystic change are recorded. Mumps rarely has a sterilising or other ill-effect in the female because the capsule of the ovary is more elastic than that of the testis; so ischaemic injury to the graafian follicles is not likely. Even if some follicles are destroyed, enough remain for full reproductive function.

### Clinical Features

The only evidence of oophoritis as a rule is the occurrence of lower abdominal pain for a few days during an acute infective illness. A single menstrual period may be disturbed in its onset, but it is difficult to know whether this is the effect of the oophoritis or of the general systemic upset. If an abscess forms, or if the condition does become chronic, the clinical features are those described under salpingo-oophoritis.

### Treatment

In the acute phase no treatment other than that of the causal illness is required. If an abscess forms, the treatment is as described for salpingo-oophoritis.

## PELVIC PERITONITIS

### Aetiology

- Any infection of the genital tract
- Infection from the alimentary tract: appendicitis, diverticulitis
- As part of general peritonitis: pneumococcal and tuberculous infections
- *Foreign bodies*: These reach the peritoneum via the bowel, uterus or the posterior vaginal fornix, or are left at operations.
- Rupture or perforation of an infected uterus
- *Following pelvic haematocoele*: Infection of blood clot is seen in ectopic pregnancy and also following pelvic operations. Postoperative pelvic peritonitis
- Nearly always means inadequate haemostasis.
- *Chemical*: This includes a variety of possible irritants—urine, bile, vernix caseosa, meconium (spilled at the

time of caesarean section), radio-opaque media used in salpingography, talc from gloves or drapes used at operations, and the contents of ruptured cysts. The fluid from endometriotic cysts is irritant but the worst in this respect is the sebaceous fluid from dermoid cysts. This, like vernix caseosa, can produce the most violent reaction which ultimately leads to very dense adhesions.

Irritant fluids used for the purpose of douching, and especially those used by women themselves with the idea of inducing abortion, may pass through the uterus and tubes to produce pelvic or general peritonitis. A favourite in the past was a solution of soap and large quantities of this fluid had to be removed from the abdominal cavity. The risk of this accident taking place is minimal after the uterine cavity is filled with a pregnancy. Abortifacient pastes are another cause.

### Pathology

The initial acute inflammatory reaction may subside or be followed by exudation and pus formation. Although complete resolution is possible, pelvic adhesions are left in most cases. Pus can collect to form *a pelvic abscess* and the causes of this condition are all those stated above. If neglected, the abscess ultimately bursts into the rectum or bladder but very rarely into the vagina whose investing fascia is strong.

### Clinical Features

These are the same as for acute salpingo-oophoritis and, in the case of residual pelvic adhesions, as for chronic salpingo-oophoritis. The leading symptoms of acute pelvic peritonitis, with or without abscess formation, is often *diarrhoea*.

### Treatment

In the acute stage the treatment is the same as for salpingo-oophoritis, except that any cause such as a foreign body or ruptured cyst must be removed. A pelvic abscess or a collection of infected blood requires drainage; this is usually best established through the posterior vaginal fornix, *not* the rectum. Sometimes abdominal drainage is more efficient. Residual pelvic adhesions only require surgery if they cause symptoms.

### PELVIC CELLULITIS

Pelvic cellulitis is a condition of inflammation affecting any of the loose cellular tissue lying above the levatores

ani. It occurs most obviously in the bases of the broad ligaments (*parametritis*) and the uterosacral ligaments (*posterior parametritis*).

### Acute and Subacute Cellulitis

#### Aetiology

Organisms travel to the cellular tissue from infected adjacent pelvic organs by way of lymphatic channels but they can also gain direct access through perforations and tears, surgical or obstetrical, in the vaginal fornix, cervix, uterus, rectum and bladder.

#### Adjacent Infections

- Cervicitis and endometritis, including secondary infection complicating neoplasms and foreign bodies. Cellulitis associated with cancer of the cervix makes it difficult to define the extent of the growth.
- *Salpingo-oophoritis*: Some degree of parametritis invariably accompanies severe salpingo-oophoritis. It accounts in large measure for the fixation of the pelvic organs in this disease.
- Diverticulitis, carcinoma of the rectum and other conditions of the large bowel can lead to cellulitis of the uterosacral ligaments.
- Carcinoma of the bladder and cystitis, if extensive, can cause cellulitis in the uterovesical space.

#### Pelvic Operations

- Dilatation and curettage, especially if carried out in the presence of endometritis
- Ablative procedures on an infected cervix
- *Hysterectomy*: Some degree of cellulitis of the tissues at the vaginal vault is common after total abdominal or vaginal hysterectomy, but is usually preceded by haematoma formation.
- *Lower segment caesarean section*: In this case the cellulitis is anterior rather than lateral, and often represents secondary infection of a haematoma.
- Other obstetrical operations
- The insertion of intrauterine contraceptive devices or of instruments to terminate pregnancy.

#### Radiotherapy

Radiotherapy in the presence of infection can cause cellulitis. This risk is mostly seen in the case of malignant disease, but cellulitis following the insertion of radioisotopes does occur.

A special form of non-infective ischaemic 'cellulitis' is seen as a late complication of radiotherapy.

### Pathology

Anaerobic streptococci, staphylococci and *Escherichia coli* are the most likely pathogens. The loose connective tissue reacts by inflammatory infiltration and oedema; an indurated mass results. The possible further developments are: complete resolution; abscess formation, the pus tracking according to the distribution of the cellular tissue and its connections; and healing by fibrosis and scar formation. One complication is suppurative thrombophlebitis of the veins of the broad ligament and the clinical features of this can obscure those of cellulitis.

Cellulitis of the broad ligament and paracolpos is nearly always *unilateral* and, in puerperal infection, is most often left-sided, as are cervical lacerations. Puerperal cellulitis is also more extensive and obvious because the amount of cellular tissue is increased and the vascular channels are dilated by pregnancy. Cellulitis of the uterosacral ligaments is usually *bilateral* and appears as a horseshoe-shaped swelling with the two arms passing back beside the rectum.

### Clinical Features

Symptoms and signs do not usually make their appearance until 7-14 days after the original infection. The typical picture is presented by puerperal cellulitis. This ordinarily becomes manifest about the tenth day when the patient experiences a rise in temperature and pulse rate accompanied by malaise. On reviewing the case it may be noted that slight evening pyrexia has been present for some days previously for no apparent cause. The patient does not appear to be seriously ill, but may complain of discomfort in the lower abdomen or pelvis on the affected side. The pain is not severe and muscular rigidity is absent because the lesion is extraperitoneal. Other possible complaints are frequency of micturition, dysuria, diarrhoea and painful defaecation. The formation of an abscess brings further general systemic disturbance with a high swinging temperature and rigors.

The physical signs are very striking. The cellulitis gives the impression of a hard mass, *continuous with the uterus* and extending towards the wall of the pelvis. It may be so large as to be palpable abdominally, otherwise it is detected on pelvic examination. Induration of the

uterosacral ligaments is often felt more easily *per rectum*. If the broad ligament is involved, the swelling is unilateral and pushes the uterus to the opposite side. The mass is tender, woody in consistency and fixes all organs in its vicinity, especially the uterus.

An abscess may point: into the rectum; into the bladder; into the vagina; on the lower anterior abdominal wall, especially above the inguinal ligaments; over the femoral canal; in the thigh via the obturator foramen; or in the buttock via the sacrosciatic notch.

### Diagnosis

The diagnosis is usually easy but confusion may arise over the following.

- *Acute salpingo-oophoritis and pelvic peritonitis*: In this condition the pain is *bilateral* and more intense, abdominal rigidity is present and the temperature is usually higher. Diarrhoea is more likely. Any swelling is separate from the uterus.
- *Malignant disease*: Extension of growth from the cervix, corpus or ovary into the broad or uterosacral ligaments
- Diverticulitis and carcinoma of the lower bowel
- Ectopic pregnancy, especially if it is intraligamentary
- Broad ligament haematoma.

### Treatment

#### Medical and General

As for acute salpingo-oophoritis.

#### Surgical

An abscess which is pointing and easily accessible should be drained; otherwise, surgery is to be avoided. The ideal drainage route is through the posterior vaginal fornix but the site of incision is determined to a large extent by where the abscess points. An extraperitoneal inguinal approach is best in certain cases.

#### Prognosis

Except in old and debilitated women the prognosis is good and the cellulitis usually resolves completely. It sometimes heals by fibrosis (*see below*). Unlike salpingo-oophoritis, and because the endosalpinx is not affected, cellulitis does not lower fertility. Moreover, future pregnancies do not involve any special risk of reawakening the infection.



## CHRONIC CELLULITIS

### Aetiology and Pathology

Chronic cellulitis is a condition of fibrosis, or of long persisting inflammatory exudation, in the broad and uterosacral ligaments. It usually represents the quiescent end result of acute cellulitis, but can be a response to a chronic low-grade infection in an adjacent organ such as the cervix and rectum, an infected cancer for example.

### Clinical Features

The symptoms are chronic aching pain in the pelvis, often one-sided; deep-seated dyspareunia; sacral backache, especially if the uterosacral ligaments are involved; and menorrhagia and discharge if there is an associated congestion of the uterus and cervix. On vaginal examination a scar in the cervix and vaginal vault, with underlying induration in the broad ligament, is easily detected. When the uterosacral ligaments are implicated they feel prominent, hard and tender. The uterus is fixed on the affected aspect; attempts to move it reproduce the patient's pain.

### Diagnosis

The diagnosis of chronic cellulitis should not be made a cover for all one-sided pelvic pains for which another cause cannot be found. Clear evidence of previous infection or of associated disease should be present. Posterior parametritis has to be distinguished from endometriosis of the uterosacral ligaments and rectovaginal septum.

### Treatment

#### Medical and General

This is the same as for chronic salpingo-oophoritis.

#### Nerve Block

Injection in the ilioinguinal region with long-lasting anaesthetic solutions may relieve pain and tenderness, and can usefully be combined with treatment of associated cervical lesions.

#### Surgery

Trachelorrhaphy, freeing of cervical and vaginal scars, and treatment of associated chronic cervicitis may give relief, especially if the complaint is dyspareunia.

## PELVIC INFLAMMATORY DISEASE (PID)

Pelvic inflammatory disease (PID) is a clinical syndrome associated with ascending spread of microorganisms from the vagina or cervix to the endometrium, fallopian tubes and/or contiguous structures, not associated with pregnancy or surgery. In the foregoing sections, you have read about infections as they affect individual organs. What follows here is a summary to present the condition as usually encountered in clinical practice.

### Aetiology

While most cases of PID are caused by *Neisserria gonorrhoeae* and *Chlamydia trachomatis*, other organisms can be encountered less frequently: *Gardnerella vaginalis*, *Prevotella*, *Peptostreptococcus*, streptococci, *Haemophilus influenzae* and pneumococci.

### Clinical Features and Diagnosis

Some patients may be asymptomatic. The classic triad, however, is pelvic pain, cervical excitation pain and adnexal tenderness, often in the presence of fever. In severe cases, abdominal rebound tenderness may be present; vaginal discharge may be seen. Some women may have associated menorrhagia, metrorrhagia and urinary symptoms.

The erythrocyte sedimentation rate, total leucocyte count and C-reactive protein may be elevated; tests for gonorrhoea, *Chlamydia* or other organisms may be positive and an endometrial biopsy, if performed, may show endometritis. Tubo-ovarian masses can be demonstrated by ultrasound. Laparoscopy will confirm the presence of salpingitis.

### Sequelae

The most important long-term sequelae of PID are chronic pelvic pain, ectopic pregnancy and infertility, the management of which is discussed elsewhere.

### Treatment

The CDC guidelines for outpatient treatment of PID are as follows: cefoxitin (2 g i.m. single dose plus 1 g probenecid orally) or ceftriaxone (250 mg i.m.) or equivalent third-generation cephalosporin (e.g. ceftizoxime or cefotaxime) along with doxycycline (100 mg orally twice daily for 14 days). An alternative regimen consists of ofloxacin (400 mg orally twice daily for 14

days) along with either clindamycin (450 mg orally qid for 14 days) or metrogyl (500 mg orally bd for 14 days).

Hospitalisation is recommended in cases of severe disease, suspected pelvic abscess, cases where the diagnosis is uncertain, adolescent patients and where there is failure of or noncompliance with outpatient therapy.

In-patient regimens are as follows: Cefoxitin (2 g i.v. 6-hourly) or cefotetan (2 g i.v. 12-hourly) along with doxycycline (100 mg orally or i.v. 12-hourly). An alternative regimen consists of clindamycin (900 mg i.v. 8-hourly) along with gentamicin (loading dose 2 mg/kg body weight i.m. or i.v., followed by 1.5 mg/kg 8-hourly). This regimen is continued for at least 48 hours after the patient demonstrates significant clinical improvement, following which she is administered doxycycline (100 mg orally bd) or clindamycin (450 mg orally qid) for a total of 14 days of therapy.

Patients are discharged when the temperature is normal for 24 hours and other signs decrease or disappear. Treatment of sexual partners is important. Indications for surgery are discussed on page 355.

## SUPPURATIVE THROMBOPHLEBITIS OF THE PELVIC VEINS

### Definition

*Suppurative thrombophlebitis* is a condition in which the veins of the broad ligament become thrombosed as a result of infection within their lumen. It is to be distinguished from *phlebothrombosis* in which the vessel wall and the clot are not infected.

### Aetiology and Pathology

Suppurative pelvic thrombophlebitis is nearly always the result of puerperal or postabortal infection with anaerobic streptococci or staphylococci. The thrombi in the uterine sinuses become infected, and the processes of thrombosis and infection spread to the venous plexuses in the broad ligament and ultimately to the ovarian and uterine veins. The ovarian veins are more often affected. Portions of the infected clot break away to cause pyaemia with repeated embolism. Some degree of parametritis is nearly always present but is not usually obvious. Neither is the primary uterine infection, although gangrene and abscesses of the uterus are rare concomitants (Fig. 20.14).

### Clinical Features

Since the original uterine infection is generally low grade and gives little evidence of its presence, the disease usually only becomes clinically manifest approximately 10 days (with a range of 2-30 days) after abortion or labour. The onset can then be dramatic with a sudden rise of temperature (to 39-40.5°C) accompanied by a rigor. This denotes a breaking off of infected clot into the bloodstream. There may be typical symptoms and signs of pulmonary embolism (or a 'fainting attack'). The pulse rate rises, the patient feels ill, leucocytosis is present but localising symptoms, such as lower abdominal pain, are exceptional. Thereafter the temperature fluctuates and there may be recurrent pulmonary infarction. The fully established picture is one of pyaemia with the formation of embolic abscesses.

The physical signs in the pelvis are not remarkable unless there is associated cellulitis. The most that is found is a suggestion of thickening and tenderness in one broad ligament; the veins themselves may be palpable but it requires an expert observer to detect this. Swelling of one or both legs gives evidence that the thrombosis has spread to the common iliac vein or to the inferior vena cava.

### Treatment

#### General and Medical

This is the same as for postabortal infection, although massive doses of antibiotics may be required.

#### Anticoagulants

These combined with antibiotics are lifesaving and should always be given at the first sign of thrombosis or embolism.

#### Surgery

Ligature of the main vein proximal to the thrombosis is indicated only when recurrent embolism threatens life and cannot be controlled by other means. The ovarian and common iliac veins, and even the inferior vena cava, have been ligated with success in these circumstances. The need for such desperate measures is exceptional. It arises mainly only among poorly nourished women living in squalor, and in whom septic abortion (probably criminal) has been neglected.

# CHAPTER 21

## Genital Tuberculosis

Introduction	361
Clinical Profile	361

### INTRODUCTION

Genital tuberculosis (TB) in females is found in 0.75 to 1 per cent of gynaecological admissions in India with considerable variation from place to place. The disease is responsible for 5 per cent of all female pelvic infections and occurs in 10 per cent cases of pulmonary tuberculosis. Although most of the affected belong to reproductive age-group, the disease has been reported in postmenopausal females as well. Lately, an increase in the trend of the disease has been reported which may be partly due to increase in the population with overall rise in tuberculosis cases. The other contributory factor may be HIV infection with increased incidence of pulmonary and extra-pulmonary forms of tuberculosis including the drug resistant forms. A rare case of vaginal tuberculosis in an HIV seropositive female had been earlier reported by the author. The immunocompromised state due to HIV infection causes reactivation of endogenous tuberculosis infection to development of tuberculosis disease. Genital TB occurs mostly secondary to pulmonary tuberculosis, commonly by the haematogenous route in a manner similar to spread to other extra-pulmonary sites like urinary tract, bones and joints etc. The fallopian tubes are affected in almost 100 per cent of the cases followed by the endometrium in 50 per cent, ovaries in 20 per cent, cervix in 5 per cent and vagina and vulva in <1 per cent. However, a few reports have found endometrium to be the most commonly involved site. Direct inoculation of tubercle bacilli can also take place over vulva or vagina during sexual intercourse with a partner suffering from tuberculous lesions of genitalia.

### CLINICAL PROFILE

Clinical symptoms and of their development can be variable. Whereas infertility (in 60% of cases), pelvic pain and menstrual disorders like scanty menstruation and amenorrhoea are the usual presentation, some patients may be asymptomatic. Dysfunction of menstruation is largely attributed to endometrial caseation, infertility is considered due to pathology in endometrium and fallopian tubes and a blockage of ovum transport. The antigonadotrophic effect of *Mycobacterium tuberculosis* may be responsible for menstrual irregularities that take place in cases of active pulmonary tuberculosis having no demonstrable lesions in genital tract (Fig. 21.1).

## Diagnosis

- The diagnosis of the disease is difficult. Apart from varied clinical presentation, a past history of tuberculosis or a history of contact may not be forthcoming and an evidence of tuberculous lesion elsewhere may be lacking. The abdominal and vaginal examinations may be normal. The key to the diagnosis is a high index of suspicion.
- A high erythrocyte sedimentation rate and a positive Mantoux test are non-specific.
- The chest radiograph is normal in most cases. A pelvic ultrasound and hysterosalpingography examinations may be of some help.
- Histopathological evidence in biopsy of premenstrual endometrial tissue or demonstration of tubercle bacilli in culture of menstrual blood or endometrial curettings only can provide the certain diagnosis of disease. The best time for examining the endometrium is few days before the expected menses, when the tubercles reach their maximum growth. The portion of the endometrium most likely to show tubercles is the corneal region, where spread from the tube first occurs. Success of identifying tuberculosis is less with menstrual blood.
- Hysterosalpingography may show calcification, irregular calcified adnexa, obstruction of the fallopian

tube, a rigid pipe stem appearance, and beaded appearance, hydrosalpinx is usually moderate or slight with a club like appearance to the ampulla multiple constrictions, endometrial adhesions or obliteration partly of the cavity.

- PCR positivity is not taken as "Gold standard" for diagnosis of extrapulmonary TB since they are capable of detecting non viable bacilli and hence may not reflect active disease. Traditionally, the laboratory diagnosis of TB depends on demonstration of the causative organism, *Mycobacterium tuberculosis*, by acid-fast staining and/or growth of the organism on Lowenstein-Jensen (LJ) medium. Microscopic examination of acid-fast bacilli (AFB) requires the presence of at least 10000 organisms ml in the sample, while culture is more sensitive, requiring as little as 100 organisms ml. However, *M. tuberculosis* may take up to 8 weeks to grow in LJ medium. Besides technical drawbacks in demonstrating *M. tuberculosis* in the laboratory, a substantial number of TB lesions of the genital tract are bacteriologically mute.
- Mycobacterial culture is more sensitive compared to AFB microscopy requiring as little as 10-100 organisms/ml. BACTEC radiometric culture is based on the measurement of carbon dioxide released by bacteria during growth in liquid medium. This new method has decreased the time for diagnosis to two to three weeks. BACTEC has a sensitivity of 80-90 per cent whereas LJ medium has only 30-40 per cent.
- PCR is a rapid, sensitive and specific molecular biological method for detecting mycobacteria in both pulmonary and extrapulmonary samples from suspected TB patients. PCR detected the low number of tubercle bacilli and possibly early disease. Furthermore, the high endemicity of TB in developing countries raises the possibility of this patient harbouring a latent disease of TB. PCR is a technique where mycobacterial DNA is amplified from minute amounts of mycobacteria present in the clinical sample. PCR has been found to be very sensitive method as it can detect less than 10 bacilli per ml of the specimen and takes only 1-2 days for the report. PCR assays targeting various gene segments, including a 65 kDa protein-encoding gene, the IS6110 element and the mpt 64 gene.
- Laparoscopy should be done carefully to avoid injury to an adherent bowel loop. A laparotomy, of course, shows the presence of tubercles and can provide



**Fig. 21.1:** Hypertrophic tuberculosis of vulva. Note considerable oedema of labia majora and elephantiasis-like appearance of labia minora (from Mcleod and Read, "Gynaecology" 1955. Churchill)

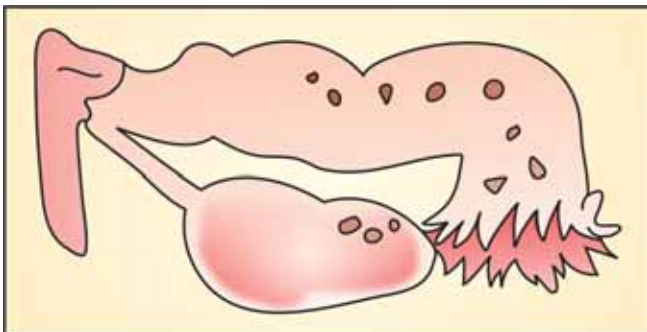
adequate histological and Bacteriological evidence. Certain conditions like tubo-ovarian mass (T-O mass) of gonococcal/pyogenic origin, pelvic endometriosis, small ovarian cyst and old pelvic haematocoele may closely mimic a T-O mass. Therefore, all the available diagnostic techniques should be combined judiciously and correlated with the clinical profile prior to instituting the antituberculosis treatment (ATT) (Figs 21.2 and 21.3).

In view of the problems of making a definitive diagnosis of genital TB in females, many physicians tend to adopt the therapeutic test for elimination of any type of TB including the genital type by prompt execution of ATT for the requested period of time. But, a prescription error or poor compliance can delay the response to treatment leading to failure, thereby resulting in continued morbidity despite the fact that good quality ATT is available. However, Rifampicin has been known to induce menstrual disturbances in a few cases which got normalised on further continuation of their antituberculosis therapy. Rifampicin induced increased enzymatic catabolism of oestrogens is believed to affect the leutinising hormone surge resulting in anovulatory cycles and causing minimal peeling of the functional layer in proliferative endometrium, which manifests in the form of oligomenorrhoea or amenorrhoea. Reversal of these disturbances is thought to take place due to the transitory nature of the effect or lowered threshold for the pituitary stimulus. Continuing search is needed for finding simpler and practicable methods for making definitive diagnosis in respect of female genital TB and the use of therapeutic test should be avoided. Prompt ATT and appropriate surgical intervention has improved the results in terms of cure from disease, restoration of female reproductive function and reduction of

procedural and postoperative complications. The chances of pregnancy in females suffering from genital TB have so far been poor (5%) even after the completion of treatment. But, results have been reported in difficult cases managed timely with combined medical treatment and a surgical intervention.

There is scant prospective data on optimal medical management of genital TB. Treatment guidelines recommend 6 months of treatment for female genital TB, providing that pyrazinamide is included for the first 2 months of treatment and that the organism is susceptible. Surgical therapy usually consists of total abdominal hysterectomy and bilateral salpingo-oophorectomy. Indications for surgery include persistence of pelvic mass, positive endometrial culture or histology, and recurrence of pain or bleeding after 9 months of treatment. Surgery should be performed at least 6 weeks after initiation of anti-TB therapy, because antimicrobial treatment facilitates the surgical procedure and reduces the risk of perioperative complications.

In vitro fertilisation has also provided a ray of hope to the desperate infertile women in recent times. Further research may help further improve the fertility rate after cure of genital TB. It may be mentioned that research is considerably hampered due to a non-availability of clear criteria for monitoring the treatment efficacy, unlike in pulmonary TB. Therefore, more research is needed, so that delivery of therapy can become more certain and therapeutic effects get better defined in terms of the normalisation of the pathologic process and the desirable reproductive function.

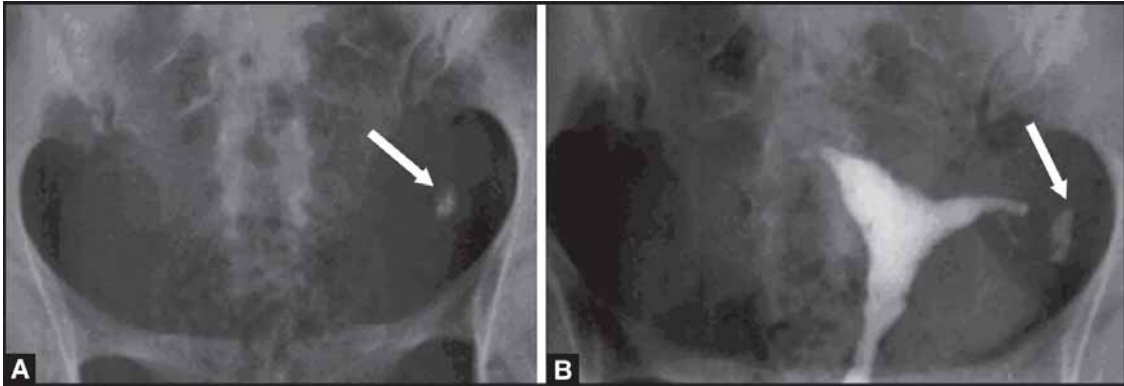


**Fig. 21.2:** Tubercular salpingitis

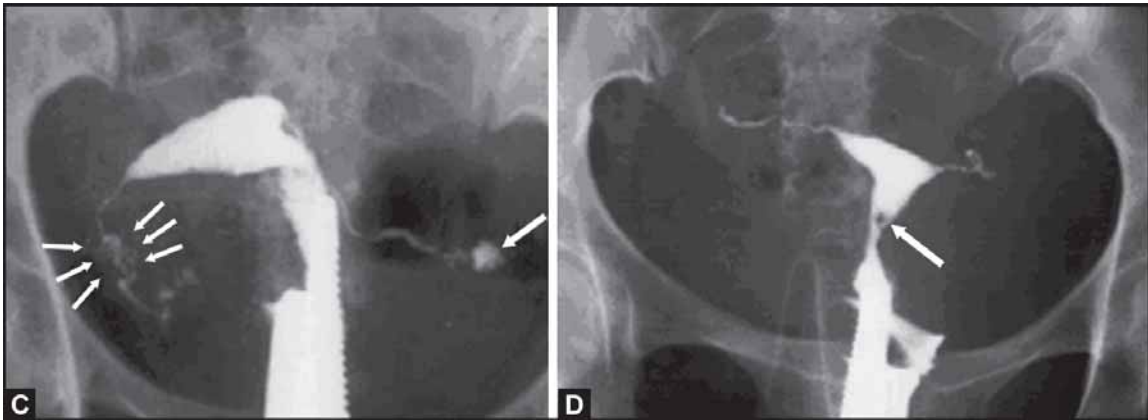


**Fig. 21.3:** Bilateral tuberculous pyosalpinx. Note the retort-shaped tubes, absence of surface tubercles and adhesions

Some of the HSG Films Suggestive of Genital TB  
(Figs 21.4A to F)

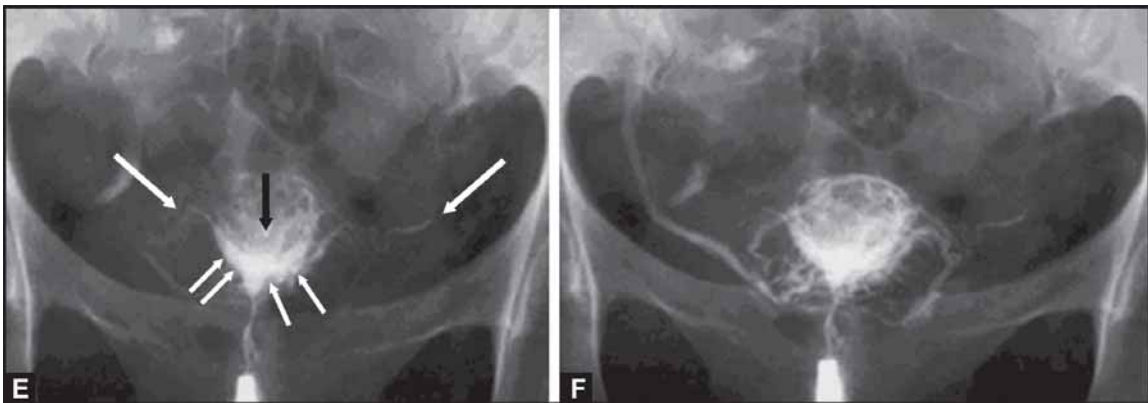


**Figs 21.4A and B:** (A) Plain film of the pelvis frontal projection shows 1066 mm calcific density (arrow) on the left side. (B) Hysterosalpingogram frontal projection shows isthmic obstruction of the left fallopian tube just proximal to the calcification. There is obstruction in the interstitial part of the tube on the right side. The endometrial cavity shows irregularity



**Fig. 21.4C:** Hysterosalpingogram frontal projection shows occlusion of both fallopian tubes. The tubes appear rigid "pipestem" and are beaded. There is a lucent filling defect in the lower uterine segment suggestive of adhesion (arrow)

**Fig. 21.4D:** Hysterosalpingogram showing lead pipe rigidity and filling defect suggestive of intrauterine adhesions near lower end



**Figs 21.4E and F:** Hysterosalpingogram shows isthmic obstruction of both the tubes (large arrows). The uterine cavity is deformed and shows "T" shaped configuration (small arrows). Also note the intravasation of the contrast medium. There is fundal impaction on the uterine cavity (black arrow)

# CHAPTER 22

## Endometriosis and Allied States

Endometriosis and Adenomyosis	365
Adenomyosis	381
Endosalpingiosis	383
Cervical Endometriosis	383

### ENDOMETRIOSIS AND ADENOMYOSIS

#### General Considerations

Endometriosis is defined as the presence of functioning uterine glands and stroma in any site outside the uterus. The condition is one of unusual interest and, although it gives rise to tumour formation (that is, a swelling), it is *not* a neoplasm. This does not mean that ectopic endometrium cannot occasionally be the site for the development of a malignant growth, although this is uncommon (*see below*).

The disease occurs in two forms: in extrauterine organs and tissues and in the uterine wall.

#### Extrauterine Endometriosis

In extrauterine endometriosis, ectopic endometrium is found, usually in other pelvic organs but sometimes in more remote sites (*see below*). Although the true nature of the lesions was recognised towards the end of the nineteenth century, it is only during the last 50 years that proper attention has been paid to the condition. Previously, pelvic endometriosis was mistaken for an inflammatory reaction because of the commonly associated adhesions. Now that it is recognised by the surgeon, it is realised that it is so common that evidence of present or past external endometriosis is found in 10-20 per cent of laparotomies carried out by a gynaecologist on white patients. It was thought to be comparatively rare in African and Asiatic women. However, it is recognised with increasing frequency in these populations also with the increasing use of laparoscopy and other diagnostic modalities.

#### Adenomyosis

In adenomyosis, the myometrium is invaded by endometrial glands from within. A minor degree of microscopic invasion of the muscle by the basal endometrium is normal, and this can be somewhat exaggerated when the endometrium is hyperplastic. These facts explain the misleading statements to the effect that adenomyosis is found in 50 per cent of all uteri removed. The penetration has to be at least one high power field from the basal endometrium for it to justify the label

of adenomyosis (Fig. 22.2). If this criterion is accepted, adenomyosis is not particularly common, not nearly as frequent as uterine leiomyomas, although all three conditions may coexist.

### General Pathological Considerations

An endometriotic lesion has the typical histological appearance of endometrium (Figs 22.3 to 22.6). Both

glands and stroma must be present to justify the designation, although the relative amounts of each vary. It is said that the glands appear first and act as organizers for the stroma. The lesion promotes a fibrous or fibromuscular tissue reaction in the host. This reaction is a diffuse one and, except sometimes in the ovary, does not lead to encapsulation of the endometrioma (Figs 22.1, 22.4 and 22.7).

Ectopic endometrium also resembles the uterine mucosa, in that it is subservient to ovarian hormones. It

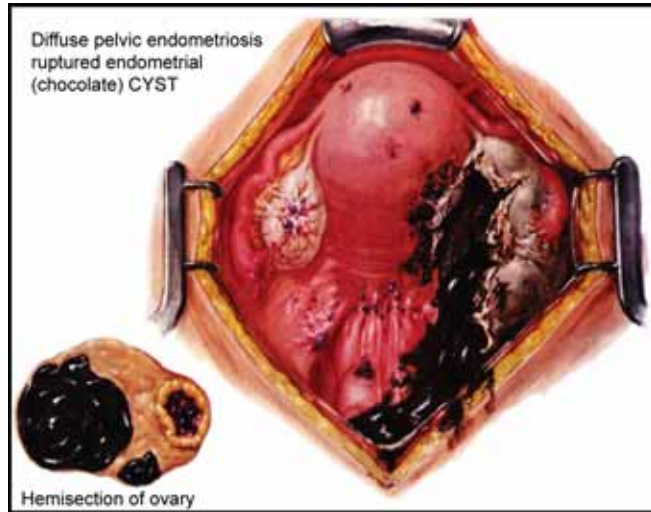


Fig. 22.1: Pathological lesions in endometriosis

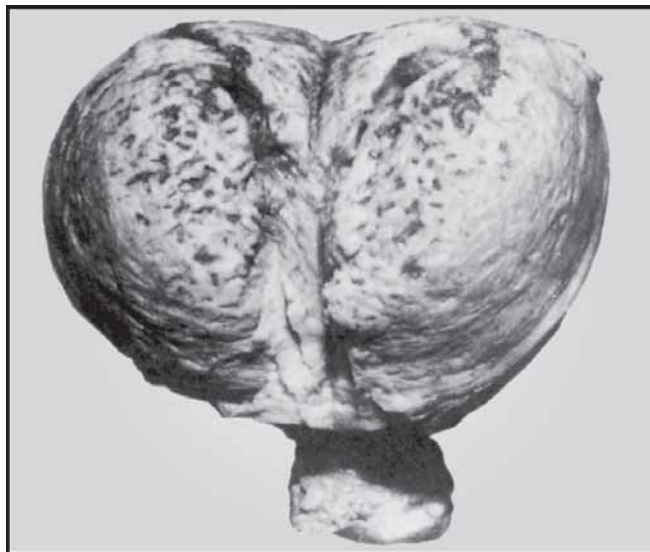


Fig. 22.2: A uterus bisected to show adenomyosis infiltrating its walls. In this case there are some small menstrual blood cysts although this condition is not very hormone-responsive. This specimen came from a woman aged 32 years complaining of infertility and menorrhagia

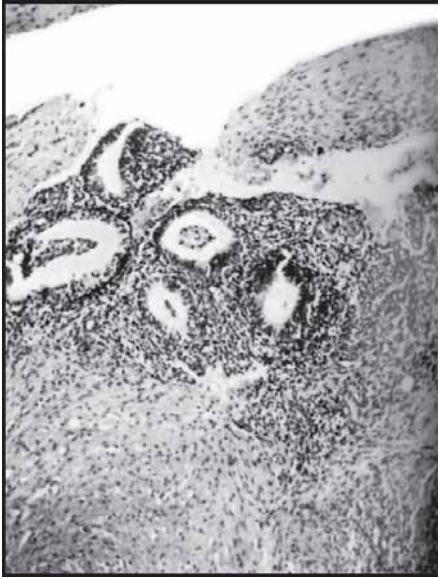


Fig. 22.3: Adenomyosis uteri



Fig. 22.4: Endometriosis of the ovary





**Fig. 22.5:** Endometriosis of the surface of the ovary

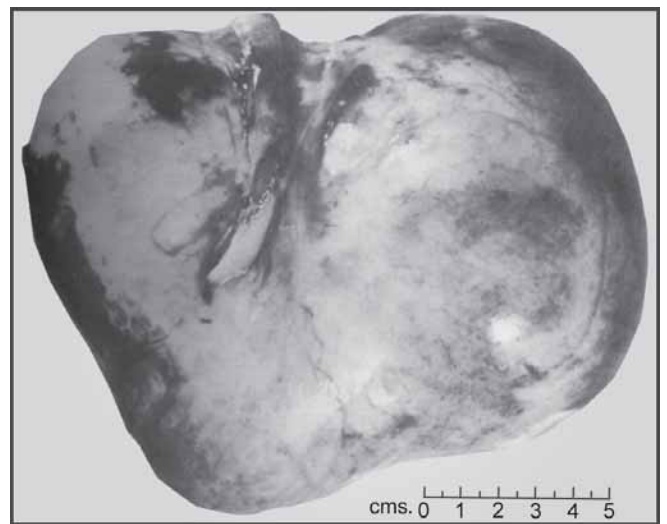


**Fig. 22.6:** Endometriosis of the vulva. The squamous epithelium of the skin lies immediately below the lesion

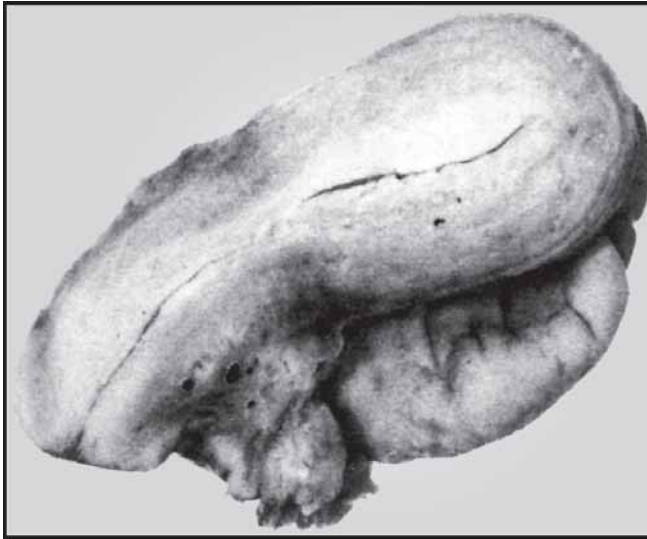
therefore typically only proliferates when the ovaries are active and atrophies after the menopause. Ordinarily an islet of endometriosis shows the cyclical changes characteristic of menstruation and, during pregnancy, its stromal cells exhibit decidual reaction. However, there is no outlet for its menstrual discharge so blood and debris collect within the tissues to form a cyst. With each menstrual episode the collection increases in size, but continual absorption of some of the fluid elements causes the blood to become inspissated and dark coloured to produce a 'tarry' or 'chocolate' cyst (Fig. 22.7). As the cyst grows, its endometrial lining is thinned and ultimately destroyed. So larger tarry cysts, such as are seen in the ovary, are lined by granulation tissue or by pseudoxanthoma cells rich in haemosiderin and their real nature may not be recognised. For this reason the operative diagnosis of extrauterine endometriosis is not confirmed histologically in more than 50 per cent of cases. This figure rises if the pathologist consults with the surgeon when selecting tissues for section, and is prepared to examine many blocks. On the other hand, any ovarian cyst into which there has been haemorrhage may be diagnosed incorrectly as endometriosis if the presence of a tarry content and pigment-laden lining cells are accepted as the only criteria.

Rupture of endometriotic cysts, even small ones, is common; scatter of their contents, which include

endometrial cells, can lead to the development of further areas of endometriosis. The peritoneum reacts sharply to the cyst material and this causes dense adhesions to seal the hole. Adhesion and fixation are also encouraged by the fact that endometriosis infiltrates adjacent tissues (Fig. 22.8). No matter how extensive the adhesions, however, it is characteristic of endometriosis that the fallopian tubes are almost invariably patent. This



**Fig. 22.7:** An unusually large endometriotic cyst of the ovary, with tarry fluid leaking on to its surface



**Fig. 22.8:** Endometriosis of the uterosacral ligaments and the rectovaginal septum. The dark areas are tiny chocolate cysts. The uterus is retroverted, and the ovary is adherent to the back of it and to the mass of endometriosis

observation is of great importance from the standpoint of the retrograde menstruation theory of origin of the disease.

Although it is generally recognised that the condition almost always becomes quiescent with the cessation of ovarian function, it is not always realised that it often does so *before* the climacteric. Indeed the lesion appears sometimes to have a very limited phase of activity, after which it becomes burnt out to leave merely adhesions and a few old blood cysts. This situation is not infrequently encountered unexpectedly at laparotomy. One of the conditions which favour retrogression is pregnancy. Generally speaking, however, the disease continues to progress and is known to progress and to recur after therapy, recurrence rates reaching 40 per cent in 5 years.

The possibility of adenocarcinoma or other malignant disease arising in an island of endometriosis is no longer disputed. A woman who had had endometriosis of the abdominal wall for at least 10 years, during which time the lesion was proved to be benign by repeated biopsy, ultimately died from adenocarcinoma at this site. Similar developments are reported in endometriosis of the rectovaginal septum, ovaries, bowel and cervix, and in uterine adenomyosis.



**Fig. 22.9:** Surface endometriosis of the ovary (arrow) shown by the dark puckered areas and the ends of broken adhesions. As is so often the case, the lesion is associated with multiple leiomyomas in the uterus

### Aetiology

Endometriosis has a family history in many. The risk of endometriosis is 7 times greater if a first-degree relative has been affected by endometriosis. Because no specific mendelian inheritance pattern has been identified, multifactorial inheritance has been postulated.

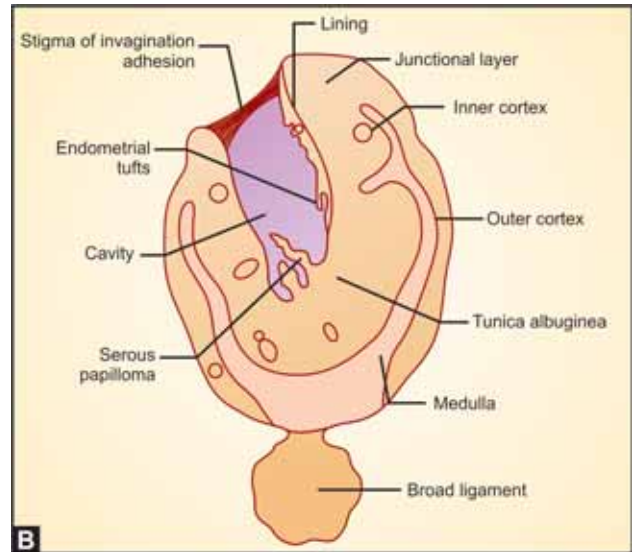
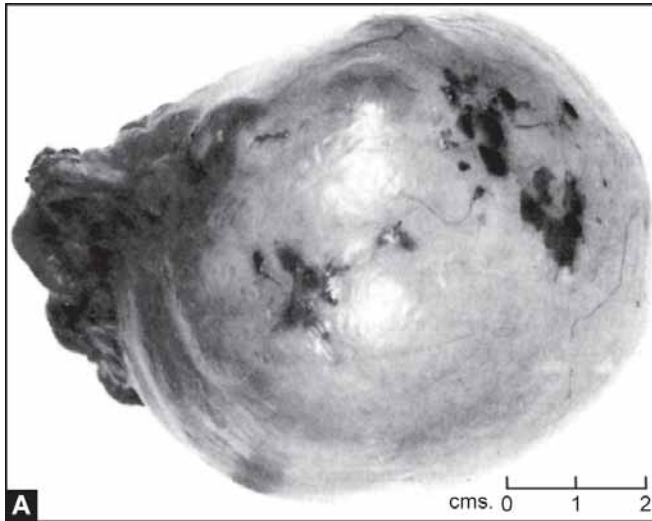
The known and supposed aetiological factors are very similar to those of uterine leiomyoma; indeed, endometriosis and leiomyomas often occur together (Fig. 22.9).

### Age

*Active* endometriosis is seen most commonly between the ages of 30 and 40 years. It can, however, occur at any time between the menarche and the menopause, even before the age of 20 years.

### Race and Family

The striking racial differences in incidence may be explained by economic and social factors, age of marriage and of childbearing as well as by genetic considerations. That genetic factors can operate, however, is suggested by the not uncommon finding of endometriosis, and of adenomyosis, affecting more than one member of a family. The risk of endometriosis is seven times higher if a first-degree relative has the disease, which is further



**Figs 22.10A and B:** (A) A serous cystadenoma of the ovary with multiple areas of menstruating endometriosis on its surface. This is a fortuitous combination but the appearance of the lesions is typical of pelvic endometriosis; (B) Endometriotic burrowing through ovarian tissue

increased in the case of homozygotic twins. The pattern of inheritance is probably multifactorial. Endometriosis has been linked with human leucocyte antigens.

#### *Social and Economic Factors*

Endometriosis is more common among highly civilised communities and among their well-to-do members. It is four times as frequent in private as in hospital practice and is therefore described as 'a disease of the rich'. This might be accounted for in part by late marriage and late childbearing in the higher income groups.

#### *Parity*

Fifty to seventy per cent of affected women are childless; many of the others have had only one or two pregnancies and those a long time previously. The association of infertility and endometriosis is established but it is difficult to say which is the cause and which the effect. It is alleged that the deliberate deferment of childbearing until a late age is a causal factor in that it exposes the susceptible tissues to an uninterrupted ovarian stimulus; pregnancy, it is said, protects by periodically suppressing ovarian activity.

#### **Oestrogens and Prostaglandins**

Although retrograde menstruation is common it is not always followed by endometriosis. It has been suggested

that endometrial cells translocated from their normal site implant only in women with specific alterations in cell-mediated immunity. It is also possible that endometrial tissue arising as a consequence of serosal cell metaplasia might, by some unknown mechanism, become hormone-dependent. Beyond doubt is the fact that an oestrogen influence is essential to the development and continued activity of ectopic endometrium in women. In the active stage of the disease the ectopic endometrial glands are out of phase with the uterine endometrial cycle and show signs of endometrial hyperplasia or atypical changes, without a secretory pattern. The altered response of the ectopic tissue to the ovarian cyclical activity may be attributed to the altered blood supply or the effect of the surrounding reactive changes.

It has been noted that endometriotic tissue, as well as normal endometrium, produces prostaglandins, and this may adversely affect ovum pick-up or tubal motility in the absence of any obvious impairment by adhesions. Increased levels of prostaglandins have also been noted in the peritoneal fluid of patients with endometriosis.

The association of endometriosis with the luteinisation of an unruptured follicle has been noted and it has been suggested that, as a consequence of the reduced output of hormones, endometrial fragments might be able to take root and develop on the ovarian surface or pelvic peritoneum. Although the evidence is limited, it

does appear that some women suffer from recurrent luteinisation of unruptured follicles, which might account for some women having both endometriosis and infertility problems.

### Retroversion

Extrauterine endometriosis is often found with retroversion and it may be that the displacement is an aetiological factor in that it favours retrograde menstruation (*see below*).

Substantial evidence suggests that endometriosis is associated with a state of subclinical peritoneal inflammation, marked by an increased peritoneal fluid volume, increased peritoneal fluid white blood cell concentration (especially macrophages with increased activation status), and increased inflammatory cytokines, growth factors, and angiogenesis-promoting substances.

### Sites

Endometriosis can occur anywhere in the body and is described even in the tissues of the arm, leg, pleura, lungs, diaphragm and kidney. Usually, however, it is confined to the organs and tissues of the abdomen and pelvis, *at or below the level of the umbilicus*. These include the omentum. Visceral lesions are often multiple.

### Ovary

The ovary is the commonest site and is involved in 30-40 per cent of cases. The lesion is nearly always bilateral. It sometimes takes the form of multiple 'burnt match head' spots on the surface of the ovary (Figs 22.9 and 22.10A and B), sometimes as the typical tarry cysts in a disorganised organ surrounded by dense adhesions (Fig. 22.11). It should be noted, however, that not all 'tarry cysts' in the ovaries are endo-metriotic. Any cyst containing old blood can present a similar naked-eye appearance.

An endometriotic cyst can reach the size of a foetal head but is rarely larger. It is usually impossible to remove it intact from its adhesions because the presence of these is a sign that the cyst wall has already been breached.

### *Pelvic Peritoneum Including the Uterovesical Pouch and the Pouch of Douglas*

The peritoneum of the pouch of Douglas is the second commonest site and a lesion there is often associated with



**Fig. 22.11:** Pelvic endometriosis. The right ovary, the seat of an endometriotic cyst, has been lifted from a mass of adhesions in the pelvis. Tarry fluid is seen escaping from the cyst and lying in the pelvis. The patient in this case was young and the ovary was conserved after resection of the affected areas. A similar procedure can be carried out laparoscopically

one in the ovaries. It may represent secondary seeding from the ovarian condition. The tarry cysts seen on the pelvic peritoneum are rarely bigger than a pea; the lesions are manifested more by puckering and thickening of peritoneum and by adhesions. The last often occlude the uterorectal space, fixing the uterus in retroversion (Fig. 22.8).

### *Outer Coat of Uterus*

Endometriosis of the ovary, pelvic peritoneum and associated ligaments, when adherent to the uterus, often invades its outer coat. The penetration is superficial and of little significance: it does not constitute adenomyosis.

### *Round Ligament, Uterosacral Ligament and Rectovaginal Septum*

Endometriosis can involve the round ligament in either its pelvic or inguinal canal portion. In the latter case it forms an abdominal wall tumour. The uterosacral ligaments are much more commonly affected and a lesion there tends to spread into the rectovaginal connective tissue. Endometriosis of the uterosacral ligaments can occur with or without involvement of the peritoneum of the pouch of Douglas.

### Fallopian Tube

Endometriosis of the outer surface of the fallopian tube occurs as part of peritoneal endometriosis.

### Intestine

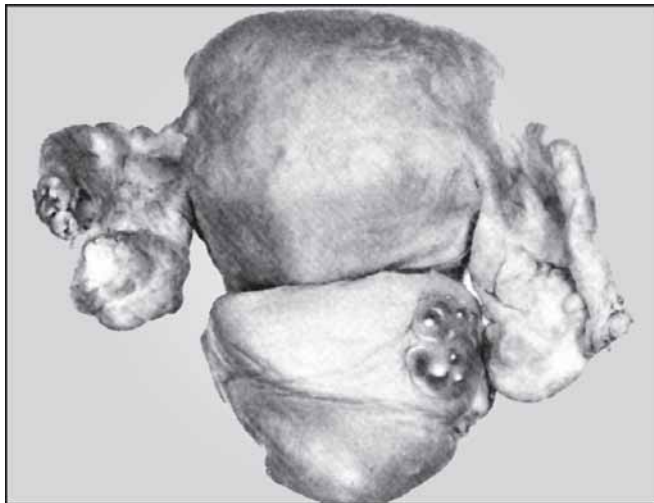
The rectum and pelvic colon can be implicated by invasion from peritoneal and ovarian deposits or by seeding. The ileum, caecum and appendix are also possible sites. No matter how extensive it may appear, the lesion rarely penetrates the mucosa, so rectal haemorrhage and the visualisation of blood cysts on sigmoidoscopy are unlikely. The main pathological change is fibrotic thickening and puckering of the outer coats of the bowel, often with stricture formation and adhesions which can cause intestinal obstruction. The condition is easily mistaken for carcinoma of the rectum or pelvic colon, and many unexpected surgical cures of apparent malignant disease in these sites can be accounted for on this basis.

### Bladder and Ureter

Endometriosis of these organs is usually explained by invasion from an adjacent site.

### Vagina and Vulva

Islets of endometriosis are sometimes found in surgical or obstetrical scars in the vagina and perineum but the



**Fig. 22.12:** Endometriotic cysts in the vaginal vault. The cuff of the vagina, removed at the time of total hysterectomy, has been turned back to show the posterior fornix with the 'blue-domed' cysts of menstrual blood lying subepithelially

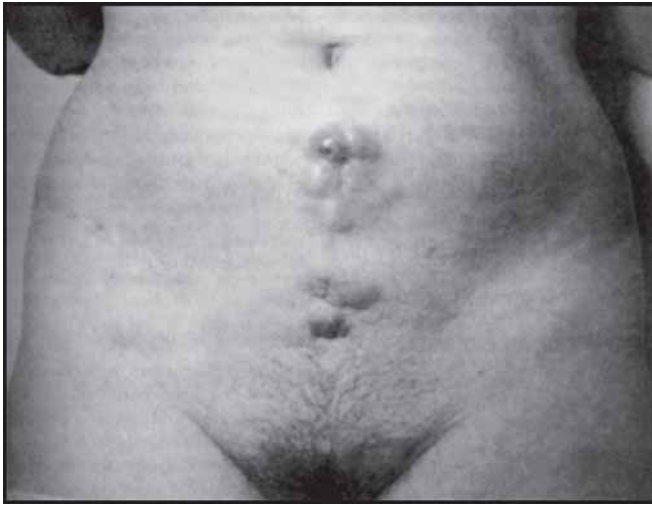
commonest site for vaginal endometriosis is the posterior fornix which becomes infiltrated from the pouch of Douglas or from the rectovaginal septum. The lesion appears as multiple small blue-domed cysts in an indurated area of the vaginal vault (Figs 22.12 and 22.13) and, when it becomes ulcerated, can be mistaken for carcinoma.

### Abdominal Wall

Endometriosis occurs spontaneously in the umbilicus and in the inguinal canal, *usually without any associated intrapelvic endometriotic lesion*. It causes a swelling which becomes bigger and more painful about the time of menstruation. It may appear blue from an underlying blood cyst and sometimes it discharges menstrual blood. The tumour is not encapsulated and the surrounding tissue is indurated. A lesion with similar characteristics sometimes occurs in abdominal wall scars following operations on the uterus or tubes (scar endometriosis). The operations most likely to be followed by this complication are hysterotomy, classical caesarean section, myomectomy, ventrofixation, removal of pelvic endometriosis and operations involving section of the fallopian tube. It is also seen in episiotomy scars. All offer the possibility of spill of müllerian epithelium into the incision (Fig. 22.14).



**Fig. 22.13:** Endometriotic cysts in the posterior vaginal fornix, the cervix being pulled forward by a volsellum on its posterior lip



**Fig. 22.14:** Endometriosis of an abdominal scar showing multiple small tumours with blood cysts. The woman affected was aged 49 years and had had endometriotic cysts of the ovaries removed 5 years previously and, subsequently, local removal of cysts from the abdominal wall on two occasions. She complained of swelling of, and bleeding from, the abdominal wall lesions with each menstrual period. The endometriosis extended deeply and widely in the muscle of the abdominal wall and it did not respond to continuous high-dose treatment with an oestrogen-progestogen preparation. So it, and any remaining ovarian tissue in the pelvis, was exposed to X-irradiation. This reduced the size of the mass and permitted its wide, although still incomplete, surgical excision. Four years later, the disease was as troublesome as ever and the masses were large. They again failed to respond to progestogen therapy and, when the woman was 55 years of age it was clear, clinically and histologically, that the lesion was malignant. During the previous 7-8 years, biopsy had been carried out on at least five occasions and always the microscopic appearances were those of endometriosis with no evidence of malignancy. There is no doubt that, in this case, a benign endometriotic condition ultimately changed to an adenocarcinoma and killed the patient

### *Lungs and Pleura*

The pleura is more often affected than the lungs and, even there, endometriosis is extremely rare. The characteristic effect is the cyclical development of pleuritic pain, and haemothorax (right-sided) or haemoptysis, with each menstrual period.

The cyclical occurrence of haemoptysis or haemothorax is suggestive but not conclusive evidence of an endometriotic lesion in the lungs or pleura.

### **Mechanism of Origin**

Many theories have been put forward to account for the development of external endometriosis but none explains all aspects of this disease.

### *Endometrial Spill*

Sampson's theory is that the growth arises as a result of spill of endometrial epithelium from the uterus when there is a backward flow of menstrual discharge through the tubes into the peritoneum. This falls first on the ovary and next into the pouch of Douglas to explain the most common sites for endometriosis. From these primary lesions there may be secondary scatter. Retrograde menstruation is a common phenomenon as can be seen during laparoscopy or laparotomy. It is said to be more likely when the uterus is the seat of leiomyomas, when it is retroverted and in cases of endometriosis as compared with normal women. It is now established that the menstrual discharge does contain viable endometrial fragments; these have been recovered from the dialysate in women undergoing peritoneal dialysis during the menstrual period. Endometriosis has been produced experimentally in monkeys by implants of their menstrual efflux or surgical transposition of the cervix to produce intra-abdominal menstruation. Moreover, it has been shown that artificially produced retroversion in these animals favours the development of the condition.

The endometrial spill theory adequately explains endometriosis in scars in the abdominal wall, vagina and perineum following pelvic operations or childbirth; and accounts for the common finding of multiple pinhead-sized areas of endometriosis on the ovarian surface and pelvic peritoneum in adolescent girls suffering from cryptomenorrhoea. In these, however, the disease does not persist or cause trouble once the obstruction to the outflow of menstrual blood is removed.

The spill theory fails to account for a primary lesion in the umbilicus and for endometriosis in remote areas such as the kidney and limbs.

### *Serosal Cell Metaplasia*

This theory is associated with the names of Ivanoff and Meyer, and is based on the fact that the uterus develops from coelomic cells which form the müllerian ducts. It postulates that embryonic cells capable of differentiating into müllerian tissue remain in and around the peritoneum of the pelvis and the surface epithelium of the ovary, or that adult cells in these sites retain the potential to differentiate into endometrium and myometrium.

This concept offers an explanation for the common finding of fibromuscular tissue alongside ectopic

endometrium. It can also account for lesions in all sites except those outside the abdomen and pelvis, and possibly those in the perineum. But even the last might have this basis because, during development, a tongue of coelom accompanies the downgrowth of the mesodermal urorectal septum which goes to form the rectovaginal septum and perineum. It is said that even limb buds receive a contribution from coelom. However, this theory is not well-supported by clinical data.

The induction theory is an extension of the theory of coelomic metaplasia and proposes that some biochemical factor may be responsible for the transformation of undifferentiated peritoneal cells to endometrial glands and stroma.

#### *Lymphatic and Vascular Embolism*

There is a body of evidence to show that tiny fragments of uterine endometrium frequently, and presumably normally, break off and enter the lymph or blood streams. They can be found in routine sections of lungs taken at autopsies, for example. Moreover, microscopic islands of endometrium are demonstrable in the pelvic lymph nodes in a high proportion of cases of endometriosis. Cell embolism which, incidentally, was also postulated by Sampson, is becoming more and more acceptable in explanation of certain endometriotic lesions, especially those remote from the pelvis.

It may be concluded that, although endometriosis probably is usually a result of cellular spill, the present evidence suggests that it can arise by any of the above mechanisms. They are all, however, *only potential* causes of the disease for they are operating in all women. Once endometrial cells are shifted from their normal site it still requires other factors to make them survive and proliferate: one of the most important of these is a good supply of oestrogen from the ovary.

#### *Immunological*

It has been proposed that certain immunologic factors may explain why all women who have retrograde menstruation do not develop endometriosis. However, there are no consistent reports regarding decreased natural killer cell activity or decreased autologous cell-mediated cytotoxicity in endometriosis. Increased secretion of tumour necrosis factor, of epidermal growth factor, of macrophage-derived growth factor from macrophages and of adhesion molecules like integrins may promote pelvic implantation of endometrial tissue.

T- and B-lymphocytes can be recruited by activated macrophages. These lymphocytes may then synthesise antibodies which may play a role in the propagation of endometriosis.

#### **Symptoms**

Surprisingly, *there may be no symptoms*, even when the endometriosis is widespread and advanced. The FIVE "D"s: Dysmenorrhoea, Disorders of menstruation, Dysparunia, Dyschezia and Dull ache of abdomen. Infertility is a major problem with Endometriosis.

Dysmenorrhoea is progressive which is characteristic of endometriosis. Post menstrual dysmenorrhoea is the maximum compared to the premenstrual and menstrual as the ectopic endometrium bleeds a little later than the endometrium. The symptoms signs do not correlate with the findings as with small lesion there may be maximum symptoms; maximum symptoms with minimal lesions.

#### *Dysmenorrhoea*

The *classical* symptom of extrauterine endometriosis is secondary dysmenorrhoea, commencing after the age of 30 years and gradually getting worse. In fact, it is present in only approximately 50 per cent of cases. The explanations for this are: by the time the lesion is found it may have been inactive for several years; and not all endometriomas menstruate. The pain comes on gradually for a few days before the period, when the endometriosis is becoming congested, *but is more severe during menstruation* when there is bleeding into a closed space. It can reach a maximum at *the end* of menstruation. Thereafter, the pain subsides slowly, but may not disappear completely between periods.

The site of the pain depends on the site of the lesion. With multiple pelvic deposits it is deep seated in the lower abdomen, pelvis, rectum and lower back. The pain of endometriosis on the body surface is localised to the tumour itself.

#### *Abnormal Menstruation*

Excessive bleeding is present in approximately 60 per cent of cases of pelvic endometriosis. Menorrhagia, polymenorrhoea and polymenorrhagia are all seen. A change in cycle usually means ovarian involvement. Because of residual adhesions and vascular upset, abnormal bleeding can continue even when the disease is quiescent.

### *Infertility*

The investigation of infertility, especially since the introduction of the laparoscope, has led to an increase in the diagnosis of endometriosis. Several possible mechanisms have been suggested for this association. The tubes are invariably open, but there may be pelvic adhesions, distorted anatomy and altered tubal motility which result in impaired ovum pick-up; the alterations in prostaglandins, macrophages and cytokines mentioned above may lead to enhanced phagocytosis of sperm; hormonal dysfunction may lead to anovulation, the luteinised unruptured follicle and luteal phase deficiency; and there may be early pregnancy losses. We still do not fully understand how endometriosis causes infertility or how infertility causes endometriosis.

### *Dyspareunia*

Deep-seated pain on coitus is particularly likely when the pouch of Douglas and rectovaginal septum are affected, and when there is an associated fixed retroversion.

### *Pain on Defaecation*

This symptom is often only elicited by a leading question. It occurs when the endometriosis involves or is close to the rectum, and is more noticeable at the time of menstruation when the tumour is larger and more tender.

### *Tumour Formation*

The patient may herself notice a swelling, especially in the case of a lesion of the abdominal wall or perineum. This exhibits cyclical enlargement and tenderness with menstruation and, if superficial, may discharge blood.

### *Abdominal Pain*

#### *Chronic*

Endometriosis forming cysts and adhesions among the pelvic organs causes a chronic aching discomfort in the lower abdomen and pelvis sometimes referred to the groins, hips and thighs. This undergoes menstrual exacerbations.

#### *Acute*

A sudden and severe pain, with all the accompanying *symptoms and signs of an acute abdomen*, is experienced

when a blood cyst ruptures. Such an accident is most likely about the time of menstruation and this coincidence, together with careful analysis of other symptoms and signs, helps to avoid the common error of diagnosing acute appendicitis. I have even seen such a case opened as a case of ectopic pregnancy.

### Other Symptoms

General ill-health and malaise are not uncommon with pelvic endometriosis. *Intermittent pyrexia*, especially at the time of menstruation, is present in at least 10 per cent of cases and is caused by absorption of the degenerated products of the retained blood. Frequency, strangury and sometimes haematuria at the time of menstruation are features of urinary tract endometriosis. Other possibilities include symptoms of intestinal and ureteric obstruction.

### Physical Signs

Small multiple lesions may not give any sign of their presence during physical examination. The vulva, vagina and cervix should be inspected first with a speculum to rule out any deposits, though these are rare. Larger or easily accessible deposits are palpable as fixed, tender and nodular swellings with surrounding induration. Even if a definite tumour is not palpable, some or all of the pelvic organs are fixed and any attempt to move them reproduces the patient's pain. A fixed retroversion is a common finding. Involvement of the uterosacral ligaments and rectovaginal septum gives rise to a characteristic tender shotty thickening ('cobblestones') above and behind the posterior fornix, which may be better appreciated during the menses.

### Diagnosis

It must first be emphasised that symptom-producing endometriosis which is active, and sometimes when it is inactive, can usually be diagnosed before operation. The diagnosis merely requires proper attention to the details of symptoms and physical signs. It is possible even when the lesion is too small to feel or is masked by large myomas. Nevertheless, tiny islets are often only revealed by laparoscopy carried out during the investigation of infertility or other complaints. Typical laparoscopic findings are the 'powder-burn' lesions on the peritoneal surface.



However, apart from these dark brown or bluish nodules or cysts, there may be subtle lesions which include red implants, white plaques, scarring, serous or clear vesicles, pseudocysts and yellowish-brown colour of the peritoneum, and adhesions on the undersurface of the ovaries. Therefore, a meticulous examination of the pelvic and abdominal cavity is required to map the extent of the disease (Table 22.1). Larger cysts including endometriomas may be seen which are usually less than 12 cm in diameter. Histological confirmation should be sought wherever possible.

Ultrasound (Fig. 22.15A), CT scan or MRI can be used only as additional diagnostic modalities. Pelvic ultrasound helps to detect endometriomas which appear as ovarian cysts with irregular walls, low-level echoes within and occasional high-level echogenic areas which are blood clots. Peritoneal deposits cannot be delineated. CT scan and MRI do not offer any additional advantage and are more expensive. CA-125, a marker for ovarian cancer, is found to be raised in endometriosis although the levels are lower than they are in cancer. The levels have also been seen to correlate with the severity of the disease, but since there is a wide range and a wide variety

of conditions in which the levels are elevated, its greatest use may be in monitoring a patient serially for recurrence. In about 30 per cent of cases the disease is steadily progressive, while in the rest it remains stable. Spontaneous resolution has been reported.

Endometriosis (Fig. 22.15B) has to be distinguished from the following.

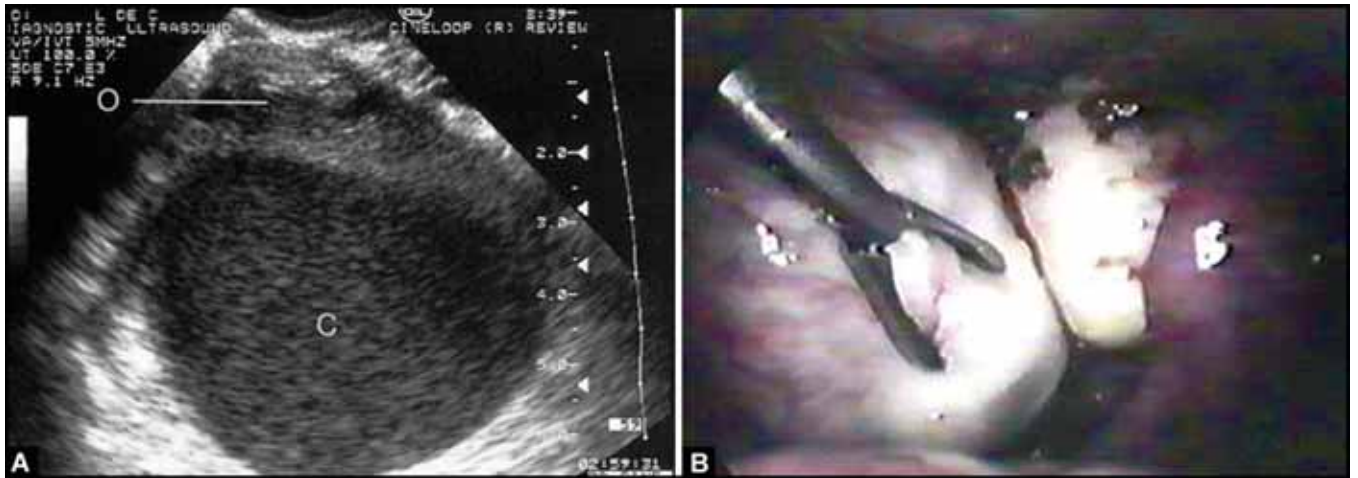
- **Chronic salpingo-oophoritis:** Menstrual irregularities and menorrhagia, dysmenorrhoea, infertility, dyspareunia, bilateral fixed tender adnexal masses, fixation of pelvic organs, general malaise and pelvic ache, and even pyrexia, are common to both. In endometriosis, the dysmenorrhoea is *intra-* or *postmenstrual*, there is no history of infection and the tubes are patent, although they may be distorted by adhesions.
- Corpus luteum cysts or neoplastic cysts
- Uterine leiomyomas
- Malignant disease of the ovary or metastases on the pelvic peritoneum
- Carcinoma of the cervix and vagina. The difficulty here arises mostly in relation to endometriosis of the rectovaginal septum and vaginal vault.

**Table 22.1: American society for reproductive medicine revised classification of endometriosis**

Stage I (Minimal)	1-5			
Stage II (Mild)	6-15			
Stage III (Moderate)	16-40			
Stage IV (Severe)	>40			
Total	Prognosis			
Ovary	<b>ENDOMETRIOSIS</b>	<1 cm	1-3 cm	>3 cm
	Superficial	1	2	4
	Deep	2	4	6
	R Superficial	1	2	4
	Deep	4	16	20
	L Superficial	1	2	4
	Deep	4	16	20
Tube	<b>POSTERIOR CUL-DE-SAC OBLITERATION</b>	<b>Partial</b>	<b>Complete</b>	
	<b>ADHESIONS</b>	<1/3 enclosure	1/3-2/3 enclosure	>2/3 enclosure
	R Filmy	1	2	4
	Dense	4	8	16
	L Filmy	2	4	4
	Dense	4	8	16
	R Filmy	1	2	4
	Dense	4	8	16
	L Filmy	1	2	4

If the fimbriated end of the fallopian tube is completely enclosed, change the point assignment to 16.

Reprinted by permission from the American Society for Reproductive Medicine (Fertility and Sterility 1997; Vol. 67, No. 5: page 819)



**Figs 22.15A and B:** (A) Ultrasound pictures of endometriotic cyst which shows fine stippling inside ovary (ground glass appearance) (B) Laparoscopy findings of endometrioma

- Carcinoma of rectum and colon, and diverticulitis
- All causes of an acute abdomen, in the case of rupture of a tarry cyst
- All causes of intestinal obstruction
- All tumours of the umbilicus
- Hernia and other swellings in the inguinal canal
- All causes of haematuria. In endometriosis, haematuria is limited to the time of menstruation.

**Classification:** Various classification systems have been proposed and these help to compare trials of therapeutic methods but they correlate poorly with the degree of symptoms experienced by the patient (Table 22.1).

## Treatment

### Expectant

The treatment of endometriosis varies with its extent, site and symptoms, and also with the age of the patient. If the lesions are small and multiple and are producing few symptoms, it may be best to leave them alone; they sometimes become inactive after a period of time. It is especially important to defer active measures in a young married woman because if she becomes pregnant, and she should be advised to try to do so, a spontaneous cure is likely. By the same token, if the complaint is infertility other appropriate procedures should be undertaken in the hope of facilitating conception.

If a woman known to have endometriosis becomes pregnant there need be little fear about the outcome.

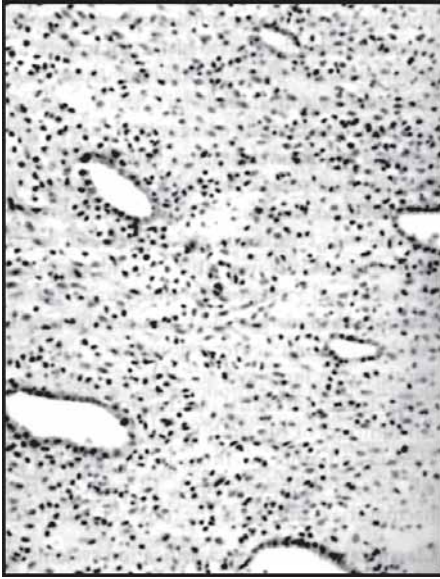
Rupture of chocolate cysts during pregnancy does occur but is rare; a fixed retroversion corrects itself; even large masses in the pelvis rarely obstruct labour, they disappear as pregnancy advances.

The following explanations are put forward to account for the disappearance or inactivation of endometriosis during pregnancy: the absence of follicular activity and ovulation; the suppression of menstruation and therefore of recurrent retrograde spill of endometrium; the conversion of ectopic endometrium to decidua, a change which favours its necrosis and absorption of the glands. This in fact is what happens when a state of pseudopregnancy is induced with progestogens (Fig. 22.16).

### Surgery

In most women with endometriosis, preservation of reproductive function is desirable. Therefore, the least invasive and least expensive approach that is effective should be used. The goal of surgery is to excise or coagulate all visible endometriotic lesions and associated adhesions—peritoneal lesions, ovarian cysts, deep rectovaginal endometriosis—and to restore normal anatomy.

**Surgical management of minimal endometriosis:** The association between infertility and minimal to mild endometriosis is controversial and poorly understood. The clinical pregnancy rate (PR) per cycle after controlled ovarian hyperstimulation (COH) with or without



**Fig. 22.16:** The effect of oestrogen-progestogen antioviulatory preparations on endometriosis. Continuous administration in large doses causes proliferation and decidual reaction of the stroma -a progestogen effect. The glandular elements undergo 'exhaustion' atrophy and appear small and inactive

intrauterine insemination (IUI) is reportedly lower in women with surgically untreated minimal to mild endometriosis than in women with unexplained infertility. It is possible that prior laparoscopic removal of endometriosis has a positive effect on the clinical PR after COH and IUI. However many studies have not proved this on a large study.

Tumours on the body surface are best excised. Deep-seated lesions call for surgery when symptoms are acute, when the diagnosis is in doubt, when tumour masses are large and when hormone therapy fails or is ruled out.

In general it can be said that laparoscopic surgery is now the method of choice in most women who require conservative surgery. It is less invasive, less expensive, has less morbidity and better postoperative results than laparotomy. Endometriotic lesions and adhesions are excised or coagulated using bipolar coagulation or CO<sub>2</sub> laser. The cyst wall of an endometrioma is removed and the remnants, if any, are fulgurated by bipolar electrocoagulation or laser. If the cyst is very small, it should be vaporised. It is important to remove the cyst wall if recurrence is to be prevented. At the same time,

adhesiolysis and preservation of normal ovarian tissue is essential in the woman who desires fertility. In general, bipolar electrocoagulation results in less adhesion formation than the laser, but recurrence rates are the same with both procedures.

Where laparoscopic facilities are not available, the same conservative surgery can be performed at laparotomy too. Limited and incomplete excision of endometriosis is followed by surprisingly good results, even when ovarian function is not sacrificed. In young women the subsequent pregnancy rate is at least 30 per cent, even when hormones are not administered postoperatively.

**Ovarian Endometriosis** Superficial ovarian lesions can be vaporised. Small ovarian endometrioma (<3 cm in diameter) can be aspirated, irrigated, and inspected with ovarian cystoscopy for intracystic lesions; their interior wall can be vaporised to destroy the mucosal lining of the cyst. Large (>3 cm in diameter) ovarian endometrioma should be aspirated, followed by incision and removal of the cyst wall from the ovarian cortex. To prevent recurrence, the cyst wall of the endometrioma must be removed, and normal ovarian tissue must be preserved.

There is increasing concern that ovarian cystectomy with concomitant removal or destruction of primordial follicles may reduce ovarian volume and reserve and diminish fertility. However it was found that a higher incidence of recurrences of cyst when the cyst was not excised. Therefore, based on the current evidence, ovarian cystectomy appears to be the method of choice.

Laparotomy is usually considered for patients with advanced stage disease, over the age of 40, where fertility is no longer required. In such cases it is often best to remove the uterus and both ovaries. While it is important to remove as much endometriotic tissue as possible, small fragments can be left behind if there is a risk of injury to the bowel because of dense adhesions, and will usually retrogress of their own accord. If there are dense adhesions with the bowel and bladder, a subtotal hysterectomy may be a safer option.

#### **Deep Rectovaginal and Rectosigmoidal Endometriosis:**

The surgical excision of deep rectovaginal and rectosigmoidal endometriosis is difficult and can be associated with major complications. Postoperative bowel perforations with peritonitis have been reported in 2 to 3 per cent of cases.

**Oophorectomy and Hysterectomy:** Radical procedures such as oophorectomy or total hysterectomy are indicated only in severe situations and can be performed either laparoscopically or, by laparotomy

The exact procedure must vary from case to case. Rarely, in the case of obstruction, it is necessary to even resect the intestine.

### Medical Treatment

There is not much of role in starting medical line of management and making the woman have amenorrhoea for six to nine months as it is not effective and more over the woman becomes older and has fecundity lowered. In order to get amenorrhoea, medications are given to manipulate the endogenous hormonal milieu and this is the basis for the medical management of endometriosis. Progestins may exert an antiendometriotic effect by causing initial decidualisation of endometrial tissue followed by atrophy. They can be considered as the first choice for the treatment of endometriosis because they are as effective as danazol or GnRH analogues and have a lower cost and a lower incidence of side effects than these agents. In most studies, the effect of treatment has been evaluated after 3 to 6 months of therapy. MPA has been the most studied agent. It is effective in relieving pain starting at a dose of 30 mg/day and increasing the dose based on the clinical response and bleeding patterns. However, a recent randomised placebo controlled study reported a significant reduction in stages and scores of endometriosis in both the placebo group and the group treated with MPA, 50 mg/day, and placebo at laparoscopy within 3 months after cessation of therapy. These findings raise questions about the need for medical therapy.

### Hormone Therapy

#### Oestrogens and Progestogens

Treatment with a combination of these hormones was introduced to mimic the conditions occurring during pregnancy which has long been known to have a beneficial effect. Large doses given continuously suppress ovulation and menstruation and often quickly bring about clinical improvement in the condition with relief of the patient's symptoms. In the endometriotic lesions, they produce a widespread decidual change in the stroma and this in turn brings about glandular

atrophy and quiet (Fig. 22.16). If this effect is maintained for a sufficiently long time, the glands may be destroyed and the endometriosis permanently cured. Generally, however, the result is only temporary and reawakening of the endometriosis can occur as long as 2 years after apparent cure.

Oestrogen—progestogen therapy is less effective for adenomyosis than for extrauterine endometriosis because the endometrium in the former is relatively insensitive to hormones. Hormone therapy also generally gives unsatisfactory results when extrauterine endometriosis takes the form of large tumour masses and chocolate cysts. Its place is in the treatment of widespread multiple small lesions and as an adjunct to conservative surgery. In these circumstances a good or satisfactory response is seen in 80 per cent of cases, and 50 per cent of patients with opportunity subsequently conceive.

Any of the low-dose oestrogen-progestogen oral contraceptive preparations can be used. It is usual to administer it continuously, and increase it if required, to suppress menstruation. Once the adequate level of dosage is reached it is continued daily for 6-9 months. The advantage of this regime is the low cost.

The difficulties and disadvantages of this treatment are as follows.

- Nausea, vomiting and malaise at the outset
- Slight breakthrough bleeding often occurs but this is of little consequence and can be controlled by stepping up the dose.
- It can cause gross hypertrophy of the uterus and enlargement of any leiomyomas which may be present. With this treatment, uterine leiomyomas may increase considerably in size. The explanation is probably oedema and degeneration, rather than hyperplasia and hypertrophy of the tumours.
- During the treatment phase the patient is inevitably infertile. If pregnancy occurs, there may be risk to the foetus.
- Long-term benefits are questionable.

#### Progestogens

Mainly because of the last disadvantage listed above, treatment with progestogens alone, continuously or intermittently, is now advocated. Again, any of several agents can be used but popular ones are medroxyprogesterone acetate (MPA), dydrogesterone and megestrol acetate. Injections of depot medroxyprogesterone acetate (DMPA) can also be effective.

By any technique, treatment for 6-9 months is necessary. During this time ovulation may or may not be suppressed, even if menstruation is, so conception is possible.

Progestogens are often used as a first line of medical management because they produce symptomatic relief and their side-effects and cost are less. MPA is started at a dose of 30 mg/day, megestrol acetate at 40 mg/day and dydrogesterone at 20-30 mg/day. The dose is increased as required. DMPA is administered in a dose of 150 mg at intervals of 6-12 weeks.

The disadvantages of this regimen are:

- Nausea, weight gain, fluid retention
- **Breakthrough bleeding:** This may require short-term oestrogen administration for about a week.
- Mood changes, depression
- DMPA should be avoided if fertility is desired as return of ovulation as well as menstruation is variable.

### Danazol

Androgens have a direct depressant action on the endometriosis and to achieve this the dose need not be so high as to suppress menstruation. Methyl testosterone was used till the introduction of danazol. Danazol is a synthetic 2, 3-isoxazol derivative of 17  $\alpha$ -ethinyl testosterone, an orally active 19-norsteroid with minimal androgenic activity. It appears to have multiple actions at various levels of the reproductive system, including direct inhibition of GnRH and/or gonadotrophin secretion, interaction with intracellular androgen and progesterone receptors, direct inhibition of multiple enzymes of steroidogenesis and alteration of endogenous steroid metabolism. It also reverses some of the immunological changes known to occur in endometriosis (*see above*). The net result of danazol administration is a pseudomenopause state. There is no stimulant phase comparable to that seen in the pseudopregnancy state with oestrogen and progestogen preparations but primary atrophy of the ectopic endometrium occurs. This leads to more rapid symptomatic relief, usually in 2-4 weeks with danazol, compared with 12-16 weeks for pseudopregnancy regimens. The complex pharmacological actions of danazol make it an effective agent for the medical treatment of endometriosis but it is expensive and therefore will not always be the first-choice therapeutic agent. The dosage regimens vary from 400

to 800 mg but the lowest dose to produce relief of symptoms is the most appropriate.

The drawbacks of this treatment are:

- Nausea, weight gain, fluid retention
- **Androgenic side-effects:** acne, oily skin, hirsutism, reduced breast size
- Hot flushes, atrophic vaginitis, emotional instability, reduced libido
- Fatigue, muscle cramps
- Liver dysfunction
- Androgenic effects on the foetus if conception occurs.

### Gestrinone

Gestrinone is a synthetic trienic 19-norsteroid which has mild androgenic and antigonadotrophic effect. It binds to the progesterone and androgen receptors, but not to oestrogen receptors thus resulting in progressive endometrial atrophy. The basal gonadotrophin levels are maintained but the mid-cycle surge is inhibited, ovarian steroidogenesis is diminished and the sex hormone-binding globulin (SHBG) levels are reduced. Symptomatic relief is seen in 80-90 per cent of patients within two months.

The dosage is 2.5-5.0 mg orally twice weekly for 6-9 months. Side-effects include weight gain, reduced breast size, muscle cramps and breakthrough bleeding but frank androgenic effects such as hirsutism and voice change are less common. Although it is not yet widely available, it is poised to replace danazol in the treatment of endometriosis.

### Gonadotrophin Releasing Hormone Agonists

GnRH agonists stimulate the synthesis and release of follicle stimulating hormone (FSH) and leutinising hormone (LH) by binding to pituitary GnRH receptors, eventually leading to a loss of pituitary receptors and downregulation of GnRH activity. FSH and LH levels decline leading to an inhibition of production of ovarian steroids. Thus this is another method of inducing a pseudomenopause. Presently, several GnRH agonists are available: buserelin, nafarelin, goserelin, leuprorelin and triptorelin. The earliest ones were administered by intranasal spray up to five times daily. Depot formulations are now available for intramuscular and for subcutaneous use. The intramuscular preparation can

be administered once every 4 weeks and has greater patient acceptability. Doses vary with the agent used, e.g. buserelin 300-400 µg intranasally tds; nafarelin 200 µg intranasally bd; goserelin 3.6 mg subcutaneously monthly; leuprorelin 3.75 mg intramuscularly monthly (see Chapter 41).

Results with GnRH agonists are similar to those with danazol or progestogens. Side-effects are related to oestrogen deprivation. Hot flushes occur but these disappear rapidly after cessation of treatment, as do other atrophic symptoms. Significant bone loss occurs: 3-5 per cent in vertebral bone. Reversibility of bone loss is equivocal, especially if serum oestradiol levels are lower than 30-45 pg/ml. Add-back regimens have been proposed to compensate for this and to treat vasomotor symptoms while maintaining the efficacy of treatment: conjugated equine oestrogens along with medroxyprogesterone acetate; norethisterone alone; or tibolone.

Medroxyprogesterone acetate (150 mg) given intramuscularly every 3 months is also effective for the treatment of pain associated with endometriosis, but it is not indicated in infertile women because it induces profound amenorrhoea and anovulation, and a varying length of time is required for ovulation to resume after discontinuation of therapy. Megestrol acetate has been administered in a dose of 40 mg/day with good results. Other treatment strategies have included dydrogesterone (20 to 30 mg/day, either continuously or on days 5 to 25) and lynestrenol (10 mg/day). The effectiveness of natural progesterone has not been evaluated.

Side effects of progestins include nausea, weight gain, fluid retention, and breakthrough bleeding due to hypoestrogenaemia. Breakthrough bleeding, although common, is usually corrected by short-term (7-day) administration of oestrogen. Depression and other mood disorders are a significant problem in about 1 per cent of women taking these medications.

Local progesterone treatment of endometriosis-associated dysmenorrhoea with a levonorgestrel-releasing intrauterine system for 12 months has resulted in a significant reduction in dysmenorrhoea, pelvic pain, and dyspareunia; a high degree of patient satisfaction; and a significant reduction in the volume of rectovaginal endometriotic nodules. Although the results are promising, none of these pilot studies included a control group. Further randomised evidence is needed to determine whether intrauterine progesterone treatment is effective in the suppression of endometriosis.

### *Progesterone Antagonists*

Progesterone antagonists and progesterone receptor modulators may suppress endometriosis based on their antiproliferative effects on the endometrium, without the risk for hypo-oestrogenism or bone loss that occurs with GnRH treatment.

Mifepristone (RU-486) is a potent antiprogestagen with a direct inhibitory effect on human endometrial cells and, in high doses, an antiglucocorticoid action. The recommended dose for endometriosis is 25 to 100 g/day. In uncontrolled studies, mifepristone, 50 to 100 mg/day, reduced pelvic pain and induced 55 per cent regression of the lesions without significant side effects. In an uncontrolled pilot study, mifepristone, 5 mg/day, resulted in pain improvement, but there was no change in endometriosis lesions, suggesting that this dosage is probably too low.

### **Combined Medical and Surgical Therapy**

Medical treatment has not much of place preoperatively but more postoperatively to deal with residual macro- or microscopic disease. In women who desire fertility, it is a matter of speculation whether patients should be subjected to further suppression or induction of ovulation. In general, it is agreed that if adequate surgery has been possible, the sooner the patient is allowed to conceive the better, as the best outcome for fertility is immediately after surgery. Compared with surgery alone or surgery plus placebo, postoperative hormonal treatment has no effect on pregnancy rates. Postoperative medical therapy may be required in patients with incomplete surgical resection and persistent pain.

Based on several retrospective studies, several investigators have suggested that the pregnancy rate after IVF may be lower in women with endometriosis than in women without the disease.

### *Treatment of Recurrent Endometriosis*

Therapeutic options and decisions remain the same in recurrent endometriosis, but before planning repeated conservative surgery in a patient with severe symptoms it may be in her best interests to discuss the benefits of a radical surgical approach.

### *Aromatase Inhibitors*

Treatment of rats with induced endometriosis using the nonsteroidal aromatase inhibitor fadrozole

hydrochloride resulted in a dose-dependent volume reduction of endometriosis transplants, but these products have so far not been used in published human studies. Treatment of severe postmenopausal endometriosis with an aromatase inhibitor, anastrozole, 1 mg/day, and elemental calcium, 1.5 g/day for 9 months, resulted in hypoestrogenism, pain relief after 2 months, and after 9 months a 10-fold reduction in the 30-mm diameter size of red, polypoid vaginal lesions, along with remodelling to gray tissue. No other data are available, except this case report .

### Selective Estrogen Receptor Modulators

**Raloxifen:** In animal models, raloxifene therapy resulted in regression of endometriosis. The effect was seen in both a surgically prepared, rat uterine explant model and in Rhesus macaques diagnosed with spontaneous endometriosis before exposure.

### Assisted Reproduction and Endometriosis

The treatment of endometriosis-related infertility is dependent on the age of the woman, the duration of infertility, the stage of endometriosis, the involvement of ovaries, tubes, or both in the endometriosis process, previous therapy, associated pain symptoms, and the priorities of the patient, taking into account her attitude toward the disease, the cost of treatment, her financial means, and the expected results. Assisted reproduction, including controlled ovarian hyperstimulation with intrauterine insemination, IVF, and gamete intrafallopian transfer, may be options for infertility treatment in addition to surgical reconstruction and expectant management. IVF is the method of choice when distortion of the tuboovarian anatomy contraindicates the use of superovulation with intrauterine insemination or gamete intrafallopian transfer.

## ADENOMYOSIS

### Pathology

Adenomyosis usually involves the corpus, sometimes only one of its walls or a part of it. Rarely, it is found in the cervix (Fig. 22.17). Cervical endometriosis has special facets. What follows is concerned with corporeal adenomyosis.

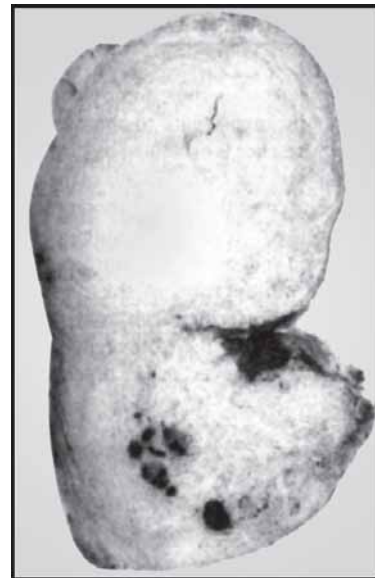
The myometrial lesion has the general characteristics of endometriosis. Its special feature is that its response

to ovarian hormones is limited; often it does not menstruate at all, and tarry cysts when present are small and few (Figs 22.2 and 22.3). Secretory activity in the glands during the luteal phase of the cycle is found in only 10-30 per cent of specimens and is then limited. This is because the adenomyoma is composed of *basal* type endometrium which is normally insensitive to an endocrine stimulus.

On the other hand, the fibromyomatous tissue reaction is well developed and, to the naked eye, the resulting tumour looks like a myoma, its cut surface having a similar striated and whorled appearance. The distinguishing features are that *adenomyosis has no capsule*, and it usually produces a diffuse enlargement of the uterus in contrast to the well circumscribed nodules characteristic of leiomyomas. When adenomyosis is localised it is most likely to be situated in the posterior wall of the uterus.

### Mechanism of Origin

The established view is that adenomyosis always represents a downgrowth from the basal layer of the endometrium. No matter how deeply it may be situated, a gland, it is said, can always be shown by serial sections to communicate with the uterine cavity. It is sometimes suggested, however, that adenomyosis arises *de novo* in the myometrium and that the change may commence in



**Fig. 22.17:** Endometriosis of the cervix with multiple small tarry cysts

multiple sites. This is not unreasonable, bearing in mind that all uterine tissues have a common origin. The finding of adenomyosis unconnected with the endometrium might also be explained on the basis of venous or lymphatic embolism of endometrial elements.

### *Clinical Features and Diagnosis*

The most common symptom is menorrhagia which is found in approximately 75 per cent of cases. It is gradually progressive over several years and is caused by enlargement of the uterine cavity (bleeding area) and by an increased blood supply. Other theoretical causes for the menorrhagia are impaired contractility of the myometrium and associated endometrial hyperplasia. Dysmenorrhoea is noted by only 30 per cent of patients and, when it occurs, is mainly intramenstrual. It is more likely when the myometrium is deeply penetrated and is probably caused by disturbed uterine contractions rather than by tarry cyst formation. The increased size of the uterus can cause diurnal frequency, a sensation of weight in the pelvis, and a noticeable abdominal tumour. The patient may also complain of infertility.

The enlargement of the uterus is detected on bimanual examination. The organ is mobile and there is usually no evidence of extrauterine endometriosis. The symptoms and signs are so similar that it may be impossible to distinguish clinically between adenomyosis and leiomyoma. Pointers in favour of adenomyosis are: it tends to occur at a younger age; it rarely enlarges the uterus to more than the size of a 12-14 weeks' pregnancy; it causes a regular rather than a nodular uterine enlargement. A clinical suspicion of adenomyosis can be suggested by imaging studies, including transvaginal ultrasonography (TVUS) and magnetic resonance imaging (MRI). 'Blurring' of endomyometrial interface, subendometrial linear striations, echogenic nodules, asymmetric myometrial thickness and myometrial cyst are indicative for the diagnosis of adenomyosis by TVUS.

The deep penetration of the glands is said to give rise to a characteristic hystero-graphic appearance but this finding more often means endometrial hyperplasia. Gland openings may be visible on hysteroscopy.

The junctional zone thickness value specific for the diagnosis of adenomyosis has been debated and evaluated by various studies.

TVS has several advantages over MRI. It is widely available, relatively inexpensive compared to MRI. It is

well tolerated by most patients and generates high quality images not limited by patient size or uterine position. However, it has its limitations. It is operator-dependent and may not be reproducible in patients on follow-up. The presence of intramural fibroids can hinder assessment of the adjacent myometrium. MRI, on the other hand, is less operator-dependent.

### Treatment

#### *Surgical*

If symptoms are present the primary line of treatment is by operation. This is the only means of making the diagnosis certain. Unfortunately the tumour cannot be removed easily because it has no capsule. Hysterectomy is therefore usually necessary although, in young women desirous of having children, resection of the main portion of the diseased uterine wall has rarely been carried out. In such cases some of the adenomyosis was often left behind but this was not necessarily incompatible with a good result. Indeed, pregnancy has been reported subsequently and this without any special postoperative therapy.

#### Palliative and Medical

##### *Medical Treatments*

With the establishment of diagnostic criteria for imaging studies, it is now possible to offer women the options of non-surgical treatments. These range from local treatments such as intrauterine devices (IUDs) to systemic preparations of gonadotrophin releasing hormone (GnRH) analogues.

##### *The Levonorgestrel Intrauterine System (LNG-IUS)*

Although the intrauterine device was originally designed as a method of contraception, the addition of progesterone to the device means that it can now be used for managing menstrual disorders. Although the majority of the studies have been in women with heavy menstrual bleeding, LNG-IUS also has the potential to be used in women with endometriosis and adenomyosis. The LNG-IUS releases 20 mg levonorgestrel per day and has been shown to result in a profound reduction in menstrual blood loss in women with heavy menstrual bleeding; 20 per cent of the women using the LNG-IUS are amenorrhoeic after 1 year's of treatment. The LNG-IUS, which has contraceptive efficacy for 5 years, has



also been reported to improve dysmenorrhoea. It is likely that some of the women with dysmenorrhoea may also have undiagnosed adenomyosis. A major disadvantage of the device is frequent and variable intermenstrual bleeding and spotting during the first few months of use. There are several mechanisms that could explain the role of the LNG-IUS in adenomyosis. Use of the LNG-IUS is associated with decidualisation of the endometrium followed by atrophic changes. As a result there is a marked reduction in menstrual blood loss. Levonorgestrel also acts directly on the adenomyotic deposits. Downregulation of oestrogen receptors, which are present in both glandular and stromal endometrial tissues, occurs shortly after placement of the device and persists for at least the first year of use. Local LNG levels following uterine placement of the LNG-IUS result in very high endometrial levels of LNG compared to those in serum.

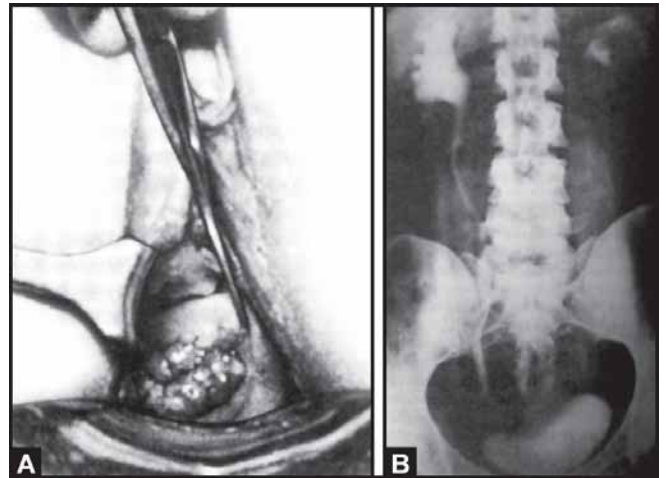
### ENDOSALPINGIOSIS

Tubal epithelium has the same origin as endometrium and has similar potentialities. Certain cases of ovarian endometriosis are thought by some authorities to be endosalpingiosis. This is because the lesions do not menstruate and because, on section, they show a tubal type of epithelium without typical endometrial stroma.

Endosalpingiosis of the tube causes no symptoms other than infertility and, as a rule, is only diagnosed by microscopic examination of the excised tissue. In the ovary, too, it is only a histological diagnosis.

### CERVICAL ENDOMETRIOSIS

In *cervical endometriosis*, the ectopic glands are truly endometrial and menstruate to some extent (Fig. 22.17). Their presence is explained by direct implantation, by embolism, or by metaplasia of the müllerian duct tissue. The condition is not uncommonly seen after operations which involve simultaneous injury to the cervix and spill of endometrium, for example, curettage with amputation of the cervix. Endometriosis of the posterior cervix may represent a spread from a lesion in the rectovaginal septum. Sometimes, however, the disease begins spontaneously in the substance of the cervix, and then extends in the same manner as cervical cancer - to the endocervix to produce polypoid masses, to the posterior fornix to produce cysts and sinuses, to the bases of the broad ligaments to surround and obstruct the ureters (Figs 22.18A and B).



**Figs 22.18A and B:** Endometriosis of the cervix in a woman aged 30 years and complaining of a bloodstained vaginal discharge for 18 months in addition to infertility, (A) A polypoid mass of endometriotic tissue protruding through the external os. The lesion was primarily in the posterior wall of the cervix but fungated into the cervical canal and also caused an opening into the posterior fornix. Extension into the right broad ligament produced physical signs similar to those of a Stage II or Stage III cancer of the cervix, (B) Pyelography reveals obstruction of the lower end of the right ureter by the extension of the endometriosis into the broad ligament on that side. The patient was ultimately treated by total hysterectomy and bilateral salpingo-oophorectomy because of the threat to renal function

The lesions vary. They may be merely superficial tiny blood cysts on the *portio*; they may be deep seated to cause distortion and fibrosis of the cervix with adhesions to the bladder base. Sometimes the cervix is grossly enlarged, completely fixed and ulcerated, the physical signs being similar to those of cancer except for the absence of friability.

Cervical endometriosis may cause no symptoms. Otherwise the complaints are irregular bleeding and discharge, contact bleeding, dyspareunia and bladder irritability.

If surgical treatment becomes necessary because of failure to respond to drug therapy, extracervical adhesions and spread can create great technical difficulties. It is usually impossible to dissect broad ligament endometriosis from around the ureters, and renal function is sometimes only saved by resecting the ureter or by sacrificing both ovaries. In one case it proved necessary to form an ileal conduit because of ureteric obstruction.

# CHAPTER 23

## Polycystic Ovary Syndrome

Pathophysiology	384
Puberty and PCOS	388
Menstrual Irregularities	389
Hirsutism	390
Metformin	391
Long Term Monitoring	393

By far the most common, although the least understood, cause of androgen excess is polycystic ovary syndrome (PCOS), accounting for a vast majority of patients seen. PCOS affects 4 to 6 per cent of women, the full blown syndrome of hyperandrogenism, chronic anovulation and polycystic ovaries. Approximately 75 per cent of anovulatory women of any cause have polycystic ovaries and 20 to 25 per cent of women with normal ovulation demonstrate ultrasound findings typical of polycystic ovaries (Fig. 23.1).

Since there are so many clinical and biochemical features in PCOS, the exact definition of PCOS can be confusing. At a recent joint European Society of Human Reproduction and Embryology/American Society for Reproductive Medicine (ESHRE/ASRM) consensus meeting (Rotterdam criteria), a refined definition of PCOS was agreed : namely the presence of two out of the following three criteria :

1. Oligomenorrhoea and/or anovulation
2. Hyperandrogenism (clinical and/or biochemical)
3. Polycystic ovaries, with the exclusion of other aetiologies

### PATHOPHYSIOLOGY (FIG. 23.2)

The hyperandrogenism and anovulation that accompany PCOS may be caused by abnormalities in four endocrinologically active compartments, (a) the ovaries, (b) the adrenal glands, (c) the periphery (fat), and (d) the hypothalamus-pituitary compartment.

In patients with PCOS, the ovarian compartment is the most consistent

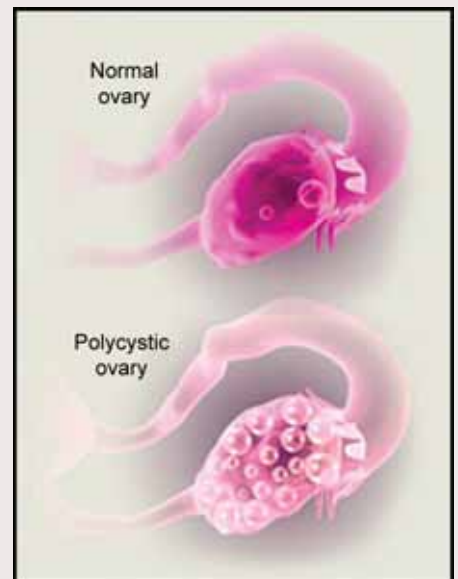


Fig. 23.1: Normal and polycystic ovary

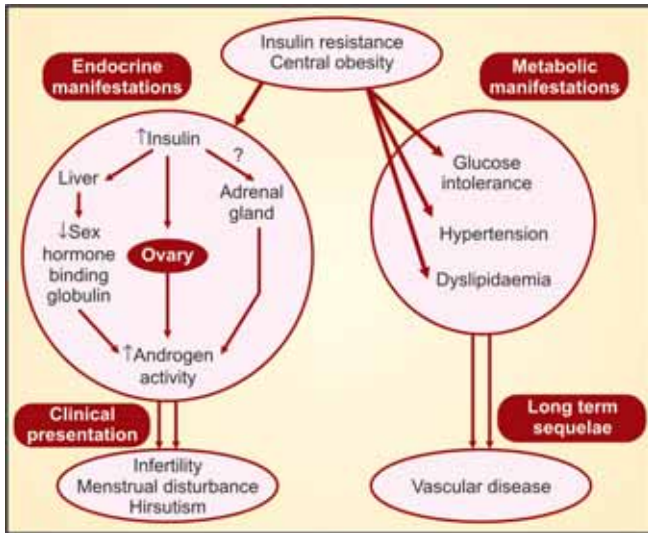


Fig. 23.2: Pathophysiology

contributor of androgens. Dysregulation of CYP17, the androgen-forming enzyme in both the adrenals and the ovaries, may be one of the central pathogenetic mechanisms underlying hyperandrogenism in PCOS. The ovarian stroma, theca, and granulosa contribute to ovarian hyperandrogenism and are stimulated by LH. This hormone relates to ovarian androgenic activity in PCOS in a number of ways and they are :

- Total and free testosterone levels correlate directly with LH levels
- The ovaries are more sensitive to gonadotropic stimulation, possibly as a result of CYP17 dysregulation
- Treatment with a gonadotropin-releasing hormone (GnRH) agonist effectively suppresses serum testosterone and androstenedione levels
- Larger doses of a GnRH agonist are required for androgen suppression than for oestrogen suppression.

The increased testosterone levels in patients with PCOS are considered ovarian in origin. The serum total testosterone levels are usually no more than twice the upper normal range (20 to 80 ng/dl). However, in ovarian hyperthecosis, values may reach 200 ng/dl or more. High intraovarian androgen concentrations inhibit follicular maturation. Although ovarian theca cells are hyperactive, the retarded follicular maturation results in inactive granulosa cells with minimal aromatase activity for conversion to oestrogens.

The adrenal compartment also plays a role in the development of PCOS. Although the hyperfunctioning CYP17 androgen-forming enzyme coexists in both the ovaries and the adrenal glands (30), DHEAS is increased in only about 50 per cent of patients with PCOS. The hyper responsiveness of DHEAS to stimulation with ACTH, the onset of symptoms around puberty, and the observation that 17, 20-lyase activation (one of the two CYP17 enzymes) is a key event in adrenarche have led to the concept of PCOS as an exaggerated adrenarche.

The peripheral compartment, defined as the skin and the adipose tissue, manifests its contribution to the development of PCOS in several ways.

- The presence and activity of 5 $\alpha$ -reductase in the skin largely determines the presence or absence of hirsutism
- Aromatase and 17 $\beta$ -hydroxysteroid dehydrogenase activities are increased in fat cells, and peripheral aromatisation is increased with body weight
- The metabolism of oestrogens, by way of reduced 2-hydroxylation and 17 $\alpha$ -oxidation, is decreased.

The hypothalamic-pituitary compartment also participates in aspects critical to the development of PCOS.

- An increase in LH pulse frequency is the result of increased GnRH pulse frequency.
- This increase in LH pulse frequency typically results in elevated LH and LH-to-FSH ratio.
- FSH is not increased with LH, probably because of the synergistic negative feedback of chronically elevated oestrogen levels and normal follicular inhibin.

About 25 per cent of patients with PCOS exhibit elevated prolactin levels. The hyperprolactinaemia may result from abnormal oestrogen feedback to the pituitary gland. In some patients with PCOS, bromocriptine has reduced LH levels and restored ovulatory function.

Genetic association and linkage analysis studies presently under way suggest an oligogenic origin for PCOS.

### Pathology

Macroscopically, ovaries in women with PCOS are 2 to 5 times the normal size. A cross-section of the surface of the ovary discloses a white, thickened cortex with multiple cysts that are typically less than a centimeter in diameter. Microscopically, the superficial cortex is

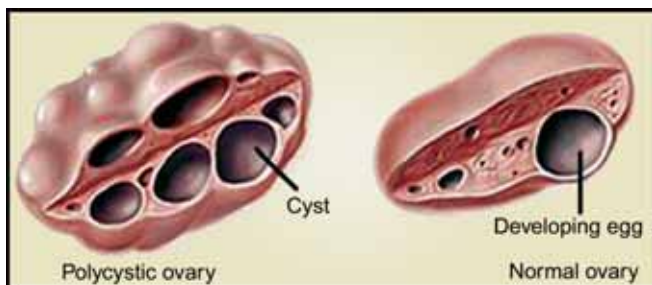


Fig. 23.3: Pathology

fibrotic and hypocellular and may contain prominent blood vessels. In addition to smaller atretic follicles, there is an increase in the number of follicles with luteinised theca interna. The stroma may contain luteinised stromal cells (Fig. 23.3).

### Clinical Features Biochemical, and Metabolic Features of PCOS

Menstrual dysfunction typically occurs in PCOS, ranging from oligomenorrhoea to amenorrhoea. As a rule, patients with PCOS exhibit anovulation. Even in hyperandrogenic women with regular menstrual cycles, the rate of anovulation is about 20 per cent. Severe acne in the teenage years appears to be a common findings of PCOS. Obesity is found in over 50 per cent of patients with PCOS. The body fat is usually deposited centrally (android obesity), and a higher waist-to-hip ratio indicates an increased risk of diabetes mellitus and cardiovascular disease in later life. Insulin resistance and hyperinsulinaemia are commonly exhibited in PCOS. Insulin resistance is now recognised as a major risk factor for the development of type 2 diabetes mellitus. About one-third of obese PCOS patients have impaired glucose tolerance (IGT), and 7.5 to 10 per cent have type 2 diabetes mellitus. Abnormal lipoproteins are common in PCOS and include elevated total cholesterol, triglycerides, and low-density lipoproteins (LDL), and low levels of high-density lipoproteins (HDL) and apoprotein A-I. Other observations in women with PCOS include an increased incidence of hypertension over the years that reaches a 40 per cent incidence by perimenopause, a greater prevalence of atherosclerosis and cardiovascular disease, and an estimated sevenfold increased risk for myocardial infarction.

Approximately 70 to 80 per cent of women with PCOS demonstrate frank elevations in circulating androgens, particularly free testosterone, and 25 to 50 per cent will have elevated levels of the adrenal androgen metabolite, DHEA-S. Prolactin levels are usually normal, although they may be slightly elevated (generally <40 ng/mL) in a small fraction of patients. The luteinising hormone/follicle-stimulating hormone (LH/FSH) ratio is greater than 2 or 3 to 1 in approximately 60 per cent of these patients. As noted, the ovaries of about 70 per cent of patients with PCOS usually contain intermediate and atretic follicles measuring 2 to 8 mm in diameter, resulting in a "polycystic appearance" at sonography.

While not part of the diagnostic criterion, many women with PCOS appear to be uniquely insulin-resistant. Approximately 50 to 70 per cent of patients with PCOS demonstrate profound insulin resistance and secondary hyperinsulinaemia, independent of body weight. In PCOS, insulin resistance usually refers to the impaired action of insulin in stimulating glucose transport and in inhibiting lipolysis in adipocytes. Insulin resistance in PCOS appears to be due to an intracellular defect of insulin signaling.

The compensatory hyperinsulinaemia, resulting from the underlying insulin resistance, augments the stimulatory action of LH on the growth and androgen secretion of ovarian thecal cells, while inhibiting the hepatic production of SHBG. Treatment of patients with PCOS with insulin sensitisers may result in lower circulating levels of LH suggesting that insulin resistance, or more likely hyperinsulinaemia, is in part responsible for the gonadotropic abnormalities observed in many women with PCOS. Since insulin is also a mitogenic hormone, the extremely elevated insulin levels may lead to hyperplasia of the basal layers of the epidermis, resulting in the development of acanthosis nigricans (a velvety, hyperpigmented change of the crease areas of the skin), and acrochordons. Overall, insulin resistance and secondary hyperinsulinaemia affects a large fraction of patients with PCOS, and may cause or augment the androgen excess of these patients.

When compared with levels found in normal women, patients with persistent anovulation have higher mean concentration of LH, but low or low normal levels of FSH. The elevated LH levels are partly due to increased sensitivity of the pituitary to releasing hormone stimulation, manifested by an increase in LH pulse

amplitude and frequency but mainly amplitude. It is noteworthy that this high levels of LH is characterised by an increased level of LH bioactivity.

The high LH and low FSH can also be due to increased frequency of GnRH pulsatile secretion. Central opioid tone appears suppressed because there is no difference in response to naloxone. Indeed the enhanced pulsatile secretion of GnRH can be attributed to a reduction in hypothalamic opioid inhibition because of the chronic absence of progesterone. This is associated with increase in amplitude and frequency of LH secretion that is correlated with the levels of circulating oestrogen. It is likely that this increased activity is taking place at both hypothalamic and pituitary sites. This altered state is also associated with a change in the circadian patterns with the highest LH values occurring in late afternoon rather than at night.

The increase in LH pulse frequency and pituitary response GnRH are independent of obesity. Obesity attenuates the LH response to GnRH and LH pulse amplitude is relatively normal in overweight women with PCO, although the increase in pulse frequency is maintained.

The increased pituitary and hypothalamic sensitivity can be attributed to the increased oestrone levels, but an important contributing factor is the impact of the 50 per cent reduction in SHBG concentration due to increased testosterone and in patients with hyperinsulinaemia, due to a direct insulin effect on the liver.

The increased LH secretion as expressed by the LH:FSH ratio is positively correlated with the increased free oestradiol. Then is no evidence to support a role for inhibin suppression of FSH. In fact insulin production in granulosa cells is suppressed. A sensitive assay for inhibin B has however detected high levels in women with PCO suggesting that multiple small follicles can suppress FSH levels by increasing the circulating levels of inhibin B.

Because the FSH levels are not totally depressed, new follicular growth is continuously stimulated, but not to the point of full maturation and ovulation, in the form of multiple follicular cysts 2-10 mm in diameter. These follicles are surrounded by hyperplastic theca cells, often luteinised in response to high LH levels. The accumulation of follicular tissue in various stages of development allows an increased and relatively constant production of steroids in response to gonadotrophic stimulation. This process is self sustaining. As various

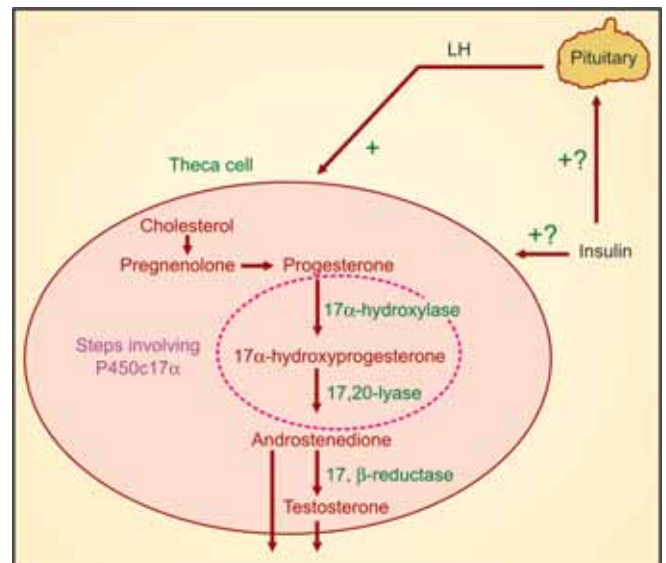
follicles undergo atresia, they are immediately replaced by new follicles of similar limited growth potential.

The elevated androgen levels compound the problem through the process of extra glandular conversion as well as suppression of SHBG synthesis resulting in elevated oestrogen levels and associated increase in free testosterone. This prevents the normal follicular development and induce premature atresia.

There is allegedly an associated enzymatic dysregulation specifically of P 450c17, the enzyme responsible for both 17  $\alpha$  hydroxylase and 17, 20 lyase activities (Fig. 23.4). This may account for the altered steroidogenesis in both ovaries and adrenal glands. The intermediates from 17 hydroxypregnenolone and androstenedione hyper-respond, testosterone rises slightly yet significantly and oestrone and oestradiol marginally. The 3 $\beta$  hydroxy intermediate pregnenolone, 17 hydroxy progesterone and DHEA rise only slightly. This coupled with hyperresponsiveness of DHEAS to ACTH in the adrenals completes the background for formation of PCO. There is growing evidence that hyperinsulinaemia may stimulate P 450c 17 enzyme resulting in hyper androgenism.

*Insulin and the Mechanism of Anovulation in Polycystic Ovarian Syndrome*

The characteristic feature of anovulation in PCOS is the arrest of growth of antral follicles after reaching a



**Fig. 23.4:** Shows the steps of P450c17 alpha enhancing the conversion of progesterone to testosterone due to increased LH and Insulin

diameter between 5 and 8 mm. This may be caused by premature activation of LH mediated terminal differentiation of granulosa cells and that hyperinsulinaemia makes an important contribution to this phenomenon. In the normal menstrual cycle, granulosa cells of the dominant follicle become responsive to the LH in the midfollicle phase at a follicle diameter of 10 mm, whereas subsidiary follicles do not respond to LH. In the preovulatory phase of the cycle, LH maintains and enhances steroidogenesis but triggers terminal differentiation so that once the granulosa layer of the dominant follicle is exposed to LH, the cells undergo only two more cell divisions before growth is arrested. Theoretically, premature activation of this LH dependent effect would result in premature arrest of growth and failure of ovulation as in PCOS. Specifically, LH stimulates oestradiol and progesterone production in cells from follicles as small as 4 mm in diameter. In contrast in follicles from, both ovulatory PCO women and normal ovaries, only dominant follicles of 9.5 mm or greater responded to LH. It is believed that the remarkable amplification of LH action by insulin makes a major combination to the arrest of follicle growth. Other endemic factors, notably hyper secretion of LH and ovarian androgens, may also have a role and an intrinsic disorder of folliculogenesis cannot be ruled out.

*Ultrasonographic examination:* This may be a useful method for the early detection and subsequent follow-up of PCOS. Generally, ovarian size is increased. The most important ultrasonographic finding is a bilaterally increased number of microcysts measuring 0.5 to 0.8 cm

with generally more than five microcysts in each ovary. As the number of microcysts increases and the ovarian volume enlarges, clinical and endocrine abnormalities become more obvious, and the condition becomes more severe (Figs 23.5 to 23.7).

## PUBERTY AND PCOS

PCOS originates in puberty. Clinical observation teaches that PCOS often develops during adolescence. Excessive hair growth usually originates from before the onset of menstrual cycles. Menarche tends to be delayed. Irregular cycles, although considered a normal phenomenon during the first gynaecological years, frequently continues into adulthood.

### Mechanism of Onset of PCOS During Puberty

Taking into account the above remarks, the following hypothesis is postulated.

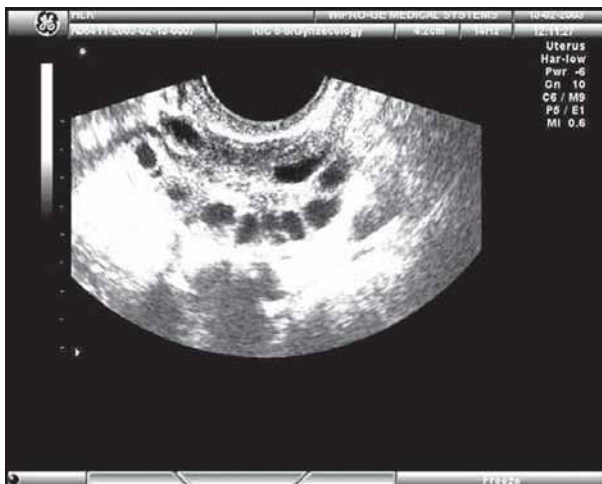
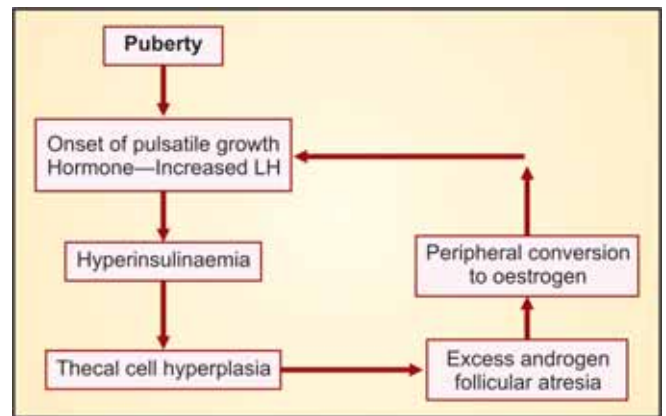


Fig. 23.5: USG pictures of PCO

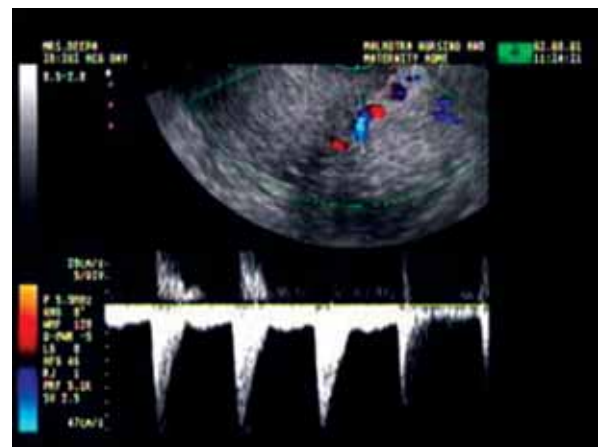


Fig. 23.6: Uterine artery doppler in PCO



Fig. 23.7: Hyperstimulated PCO

The onset of pulsatile growth hormone (GH) secretion during early puberty induces the release of IGF-1 (Insulin like growth factor -1) by the liver and most other tissues. GH also provokes insulin resistance, which selectively affects peripheral glucose. The resulting hyperinsulinaemia acting on IGF-1 causes ovarian hyperstimulation inducing thecal cell hyperplasia and excessive androgen production. The increased androgens cause follicular atresia and increased circulating oestrone levels because of peripheral conversion in adipose tissues. The altered endocrine milieu provokes increased pituitary LH secretion, which aggravates the theca cell stimulation.

After puberty the insulin and IGF-1 levels progressively decline in most patients, resulting in normalisation of clinical and morphological picture. Only in a few cases PCOS persists.

Criteria for the metabolic syndrome in women with polycystic ovarian syndrome. (Three of five qualify for the syndrome.) These women are more prone for Metabolic syndrome X with higher level of insulin resistance and its consequences.

Risk factor Cutoff values are:

1. Abdominal obesity (waist circumference >88 cm or 35 inches)
2. Triglycerides >150 mg/dL
3. HDL-C <50 mg/dL
4. Blood pressure > 130/85
5. Fasting blood sugar of 110-126 mg/dL and 2-h glucose from oral glucose tolerance test of 140-199 mg/dL.

## Management

A patient with PCOS may present to a clinician at different stages of her life. During adolescence, she may present with menstrual irregularities, skin problems such as hirsutism, acne or alopecia. She may present with obesity or acanthosis nigricans. During the reproductive years she may present with infertility. She may present in the later part of her life with problems related to long term sequelae of PCOS namely gynaecological cancer, diabetes or cardiovascular risk. The management of a patient with PCOS will depend on her presenting problems.

## MENSTRUAL IRREGULARITIES

Many women with PCOS will give a history of infrequent cycles and may be about three to six menstrual periods per year. As long as these are not unduly heavy or painful no particular medical therapy may be needed. In obese women, weight loss should be the first line of treatment. In patients who succeed to lose > 5 per cent of their body weight, this alone may restore normal menstrual regularity. A reduction in body weight of 5-10 per cent will cause a 30 per cent reduction in visceral fat, which is often sufficient to restore ovulation and reduce markers of metabolic disease. Weight loss is associated with a reduction of circulating insulin and androgen levels, which can also be achieved by using insulin-sensitising drugs.

Often an oral contraceptive can be a useful treatment for women with PCOS. Oral contraceptives can have the benefit of contraception, protection against endometrial cancer and improve skin manifestations of PCO such as hirsutism and acne. Oral pills which contains 35 microgram of ethinyl oestradiol and 2 mg of cyproterone acetate may be a good option in patients who also have hyperandrogenism (hirsutism and acne) associated with menstrual irregularity.

## Skin Manifestations

Skin manifestations of polycystic ovarian syndrome include acne, hirsutism, alopecia and acanthosis nigricans.

- **Acne:** Acne is seen in approximately one-third of PCOS patients. Mild acne can be treated topically with keratolytics such as azaleic acid, retinoids, or with antibacterials such as benzoyl peroxide, clindamycin 1 per cent lotion and erythromycin 2 per

cent gel. More severe forms generally require oral antibiotics such as the tetracyclines, erythromycin and trimethoprim. For severe case, isotretinoin is prescribed and produces long term remission in more than 70 per cent of patients.

In PCOS anti-androgens are most effective because acne occurs as a result of overstimulation of the pilosebaceous unit by androgens. Antiandrogens that can be used are cyproterone acetate, spironolactone, flutamide and finasteride. Cyproterone acetate can be given as a combined oral contraceptive pill (as mentioned above). This minimal dose has proven effective in almost 100 per cent of cases. In more severe cases, cyproterone acetate in dose of 10-100 mg/day can be given on the first 10 days of the combined oral contraceptive pill. It will take 3-5 months before any improvement can be seen. Acne will be cleared in 60 per cent of patients in 6 months and after 12 months, 95 per cent should be free of acne.

Spironolactone an aldosterone antagonist has anti-androgen action. Flutamide a non-steroidal anti-androgen can be used for the treatment of hirsutism and acne. However because of rare reports of hepatotoxicity it is not commonly used. Finasteride acts by inhibiting 5  $\alpha$  reductase can be taken orally in dose of 1-5 mg/day. It does not have much side effects. When spironolactone, finasteride and flutamide is taken, contraception is advised to avoid the potential risk of feminisation of a male foetus. It is important to inform patients that clinical response takes time and patients have to be on long term maintenance treatment to avoid relapse. The longer the duration of treatment (at least in the ethinyl oestradiol/cyproterone acetate oral contraceptive pills), the less the chance of relapse within a given periods of time.

### HIRSUTISM

Patient may present with excess hair as their main problem (*see* Fig. 24.1). Hirsutism can be treated with physical therapy such as bleaching, shaving, plucking, depilatory creams, electrolysis and laser. Bleaching of the hair with hydrogen peroxide is used to disguise pigmented facial hairs. Repeated plucking of hair is another method but may lead to permanent hair follicle matrix damage, resulting in finer, thinner hairs. Side effects include postinflammatory hyperpigmentation, folliculitis, pseudofolliculitis and, rarely scarring. Chemical depilators are usually thioglycates that disrupt the disulphide bonds of hair shaft. Electrolysis is a proven

method of hair removal. Three forms exist, galvanic (direct current electrolysis), thermolysis (alternate current electrolysis) and the blend (galvanic electrolysis and thermolysis). Side effects include erythema, hyperpigmentation and hypopigmentation, blistering and pain. Usually several treatments are required to improve efficacy.

A combined oral contraceptive pill will usually prevent new areas of excess hair from occurring but rarely are sufficient alone to cause regression of excess hair. This usually necessitates the addition of an antiandrogen therapy such as cyproterone acetate (CPA). Most women notice a regression of excess hair within four to six months but typically treatment needs to be continued for at least 1-2 years to substantially reduce hair growth and then maintenance therapy is required to keep the problem under control. Typically this is a low dose combined oral contraceptive pill. Another useful antiandrogenic treatment is spironolactone. This may be used alone or in combination with a contraceptive pill. Flutamide and Finasteride are also drugs that help reduce hirsutism.

### Alopecia

Some patients may present with alopecia. Treatment includes psychological support and hairstyling. Drugs such as minoxidil, cyproterone acetate, spironolactone and finasteride can be used but have limited role.

### Infertility

Infertility is a common presenting problem in patients with polycystic ovarian syndrome. PCOS is associated with approximately 80-90 per cent of women who suffer from infertility due to anovulation. There are several methods in inducing ovulation and basically they are reduction of insulin concentrations, follicular stimulating hormone (FSH) stimulation or a reduction of luteinising hormone (LH) concentration – or a combination of these.

### Weight Loss

The first step in ovulation induction is weight loss. Obese women (BMI > 30 kg/m<sup>2</sup>) should be encouraged to lose weight. Even patients who are overweight (BMI > 27 kg/m<sup>2</sup>) are associated with a reduced chance of ovulation. Weight loss improves the endocrine profile, and the likelihood of ovulation and a healthy pregnancy. Achieving weight reduction is, however, extremely



difficult, particularly as the metabolic status of the patient with PCOS conspires against weight loss. Different strategies can be used to affect weight loss. Dieting and exercise should be encouraged.

### Clomiphene Citrate

The simplest mode of ovulation induction is the use of clomiphene citrate. Patients can be started with 50 mg a day orally, for 5 days starting from day 2 to day 5 of a spontaneous or progesterone induced bleed. Serial transvaginal ultrasound is a good method of looking at the follicles. This can be done on the day 10 or 11 of her cycle and depending on the presence and size of follicle, serial scans can be done to assist patients to determine her fertile period. Another method is the use of urinary LH test.

There is controversy as to, for how long can one be on clomiphene citrate and what is the maximum dose of clomiphene citrate that can be taken. If the patient did not ovulate with 50 mg of clomiphene citrate, then the dose can be increased to 100 mg. However, if the patient is ovulating with a low dose, there is no benefit in increasing the dose because high dose has other side effects, which include thickening of the cervical mucus and antioestrogenic effect on the endometrium and larger the dose more than 150 mg per day may lead to ovarian hyperstimulation and its effects like hyperstimulation syndrome and multiple pregnancy.

Addition of dexamethasone at the follicular phase of the cycle has given better results. Besides clomiphene citrate the other antioestrogen that can be used is tamoxifen. Letrozole an oral aromatase inhibitor is another drug that may have potential in ovulation induction.

### METFORMIN

Metformin improves insulin sensitivity. Metformin treatment (500 mg 8 hourly) reduces hyperinsulinaemia, basal and stimulated LH levels and free testosterone concentrations in overweight women with polycystic ovaries.

#### *Mechanism of Action of Metformin*

Metformin therapy improves insulin sensitivity shown by a reduction in fasting plasma glucose and insulin concentrations. It is not effective in the absence of insulin.

- a. Metformin decreases basal hepatic glucose output in patients, producing an important mechanism through which the drug lowers fasting plasma glucose concentration.
- b. Metformin has increased glucose disposal in most studies using hyperinsulinaemic -euglycaemic and hyperglycaemic - clamp procedures, with muscle implicated as its main site of action.
- c. Metformin also increases the uptake and oxidation of glucose by adipose tissue as well as lipogenesis. However the actions of metformin on peripheral tissues *in vitro* require high concentrations and are slow in onset.
- d. Metformin increases the binding of insulin to its receptors, phosphorylation and tyrosine kinase activity of insulin receptors *in vivo*, but these action may be due to reduced plasma glucose concentrations, since they cannot be reproduced *in vitro*.
- e. Metformin also increases translocation of the GLUT-1 and GLUT-4 isoforms of glucose transporters in different types of cells, and it prevents the development of insulin resistance in cultured hepatocytes and adipocytes for long periods to high insulin concentrations.

Firstly there should not be any contraindications of metformin use. The contraindications include diminished renal function, cardiac diseases, severe pulmonary diseases, liver dysfunction, pancreatitis, concomitant use of diuretics and hypersensitivity to metformin. Patients must be informed about the adverse effects, which include gastrointestinal symptoms such as diarrhoea, nausea, vomiting especially during the initial treatment periods. These symptoms are usually transient and resolve spontaneously. Gastrointestinal symptoms can be avoided if metformin is taken with meals and if the dose is increased slowly like one per day for the first week and two per day the next week and making into three per week through out the treatment period will reduce the GI problems. Probably because of the gastrointestinal side effects, some patient may have weight loss. Patients may return to ovulatory cycles. Insulin sensitising agent troglitazone appears to be of benefit to PCOS patient but it has been withdrawn from the market because of reports of death from hepatotoxicity. The other thiazolidinedione that is being investigated is rosiglitazone.

In addition to difficulty conceiving, women with PCOS are at increased risk of miscarriage following either spontaneous or assisted conception. The intriguing question is, will insulin sensitising drug prevent early pregnancy loss in PCOS? Some reports say that metformin therapy throughout pregnancy reduces the development of gestational diabetes in women with PCOS.

In patients who do not ovulate while on metformin, clomiphene citrate can be added to induce ovulation.

If the above attempt fails, then there are several strategies. The first is laparoscopic ovarian drilling. The other is ovulation induction with parenteral gonadotrophic therapy. There is still debate as to which one should be done first.

### Laparoscopic Ovarian Drilling

Laparoscopic ovarian drilling is a simple procedure whereby several punctures are made in one or both the polycystic ovaries. This technique has superseded ovarian wedge resection. The controversy is how many diathermy points and at what wattage is to be used during ovarian cautery. It is now recommended that each ovary only about five to eight points are done with 300-400. The risk of ovarian diathermy is periovarian adhesions and the possibility of ovarian failure. Abdominal lavage has helped reduce these periovarian adhesions. Besides diathermy, laser can be used to perform ovarian drilling (Fig. 23.8).

### Gonadotrophin Therapy

Gonadotrophin therapy is indicated for women with anovulatory PCOS who have been treated with



Fig. 23.8: Laparoscopic ovarian drilling (LEOs)

antioestrogens, either if they have failed to ovulate or if they have a response to clomiphene that is likely to reduce their chance of conception (e.g. persistent hypersecretion of LH, or negative post coital tests due to the antioestrogenic effect on cervical mucus). The aim is for unifollicular development and this can be challenging. There are many protocols available but the more recent and probably the best protocol is the sequential step up, step down protocol. Patients are started with very low dose gonadotrophin (FSH) and the dose is gradually increased. When the leading follicle reaches 14 mm, the FSH threshold dose is reduced by half. This protocol appears to reduce the number of lead follicles when compared with a classic step up protocol. The aim of this low dose step up protocol is to reduce the risk of both multiple pregnancies and ovarian hyperstimulation syndrome, both of which are increased in women with PCO compared with normal ovaries. Treatment cycles can be very long, up to 28-35 days. When the leading follicle reaches 17 mm in its largest diameter, human chorionic gonadotrophin (hCG) 10,000 units is given to trigger ovulation. Some believe that there may be benefit in waiting until the follicle reaches 20 mm. Sometimes there may be sudden increase in the number of follicles. When this happens the cycle can be cancelled or converted to invitrofertilisation.

In some patients, invitrofertilisation (IVF) or even intracytoplasmic sperm injection (ICSI) may be the only option for pregnancy. Patient with PCOS with tubal blockage or with husband/male partners with low sperm counts may have to undergo IVF or IVF-ICSI. Many protocols are available when performing IVF. The most commonly performed protocol for IVF is the long protocol using gonadotrophin agonist to downregulate and followed by gonadotrophin stimulation of the ovary. This protocol is ideal for patients with PCO. The reason is that PCO patients have high LH levels. This is detrimental to pregnancy rates and also causes high miscarriage rate. As such, by pituitary downregulation, serum LH is reduced. It is also important to start these patients with low dose FSH. These patients must also be monitored closely with daily ultrasound from day eight of stimulation.

Collection of immature oocytes from PCOS patient is being researched. The immature oocytes can be matured *in vitro* and inseminated or intracytoplasmic sperm injection (ICSI) could be performed.

## LONG TERM MONITORING

There have been suggestions in the literature that women with PCOS are at increased risk of developing a number of chronic conditions and that, consequently, their health should be monitored.

Insulin resistance and resulting hyperinsulinaemia have been recognised features of PCOS for many years. It is now believed that insulin resistance is the underlying disorder of PCOS. Women with PCOS may be at increased risk of developing non-insulin dependent diabetes mellitus (NIDDM).

Clinicians have been concerned for sometime about the possibility of an increase in cardiovascular disease in women with PCOS, due to the disturbance in insulin resistance and lipid profiles that often accompany this diagnosis. Lipid studies showed that there are poorer

lipid profiles among women with PCOS compared with control women.

The association between exposure to unopposed oestrogens and an increased risk of endometrial cancer has been well established. Obesity has been shown consistently to be an important risk factor for endometrial cancer and is therefore likely to contribute to cancer risk in overweight women with PCOS. Diabetes and hypertension have been associated with an increased risk of endometrial cancer in some studies but, overall, the findings have been inconsistent and the relationship is not well defined. So whether PCO per se increases the risk of endometrial cancer is inconclusive but with added obesity and diabetes the risk is increased.

There is also probably no association between PCOS and breast cancer. The risk of ovarian cancer in women with PCOS is not well studied.

# CHAPTER 24

## Hirsutism

Virilisation and Masculinisation	394
Diagnosis of Hyperandrogenism	397
Late-onset Adrenal Hyperplasia	399

Hirsutism is the presence of terminal (coarse) hairs in females in a male-like pattern. Excessive growth of coarse hairs of the lower forearms and lower legs alone does not constitute hirsutism, although women suffering from hirsutism may note an increase in the pigmentation and growth rate of hairs on these body areas. Hirsutism should be viewed much as polycystic ovaries, as a sign rather than a diagnosis. Most commonly hirsutism is associated with androgen excess. Although the term “idiopathic hirsutism” was coined to identify the presence of hirsutism without other identifiable cause or abnormality, this may actually reflect our limited ability to assess androgen action in the peripheral compartment or even in the circulation (Fig. 24.1).

### VIRILISATION AND MASCULINISATION

Virilisation includes the appearance of sagittal and frontal balding, clitoromegaly, and severe hirsutism. Furthermore, if androgen levels are extremely elevated for a substantial period of time the features of virilisation may be accompanied by masculinisation of the body habitus, with atrophy of the breasts, an increase in muscle mass, a redistribution of body fat, and a deepening of the voice. Premenopausal patients with virilisation or masculinisation are almost always amenorrhoeic. In general, virilisation or masculinisation should raise the suspicion of an androgen-secreting neoplasm or classic adrenal hyperplasia. Occasionally girls suffering from severe insulin-resistance syndrome may exhibit a moderate degree of virilisation.



Fig. 24.1: Hirsute women

**Hirsutism:** This is most often manifested as increased “midline hair” on the upper lip, chin, ears, cheeks, lower abdomen, back, chest, and proximal limbs. The interpretation of what constitutes excessive growth is subjective and may range from an occasional hair on the upper lip to a full male-pattern beard. The psychological implications of hirsutism must not be underestimated.

### Aetiology

Excessive growth of sexual hair may be due to excessive production of androgens, increased sensitivity of the hair follicle to androgens, or increased conversion of weak androgens to potent androgens. Potential sources of increased androgens include the ovaries, the adrenal glands, exogenous hormones and other medications.

### Physiology of Hair Growth

The hair follicle and its sebaceous gland together make up the pilosebaceous unit. The hair follicle begins to develop within the first 2 months of gestation, and by birth, a child possesses all of the hair follicles he or she will ever have. Hair first appears as vellus hair, which is fine, short, and lightly pigmented. During puberty, adrenal and ovarian androgen levels rise, converting vellus hair to terminal hair, which is coarse, long, and more heavily pigmented.

Hair growth is cyclic. The three phases of the cycle are (1) anagen (growth), (2) catagen (rapid involution), and (3) telogen (inactivity). The length of each hair is determined by the relative duration of anagen and telogen and varies with different locations on the body, although each hair follicle has its own growth cycle independent of adjacent hair follicles. Scalp hair has a long anagen, from 2 to 6 years, with a short telogen.

The growth and development of the hair follicle may be influenced by several factors. First, the pilosebaceous unit is sensitive to the effects of sex hormones, especially androgens. During puberty, adrenal and ovarian androgen levels rise, converting testosterone to dihydrotestosterone, which can initiate growth and increase both the diameter and pigmentation of hair. Although conversion of vellus hair to terminal hair is essentially irreversible, removal of the androgenic stimulus will slow hair growth and stop the conversion of vellus to terminal hair. Conversely, oestrogens can retard the growth rate and result in finer hair with less pigmentation (Figs 24.2 and 24.3).

Genetic factors may also influence the pilosebaceous unit. Although males and females are born with equal numbers of hair follicles, racial and ethnic differences are noted in the concentration of hair follicles; Caucasians have a greater number of hair follicles than African-Americans, who in turn have a greater number than Asians. Different ethnic groups within each race may also exhibit differences in hair follicle concentrations.

Understanding the role of exogenous factors on the pilosebaceous unit allows one to better understand how pathologic hirsutism develops, and what factors may affect the severity of the disease process.

### Androgens

Androgenic hormones include those that stimulate terminal hair growth and cause voice and muscle changes, hair loss, clitoral enlargement, and reduction in breast size. The most common androgens are testosterone and androstenedione. Dehydroepiandrosterone sulfate (DHEAS) is an androgen precursor.

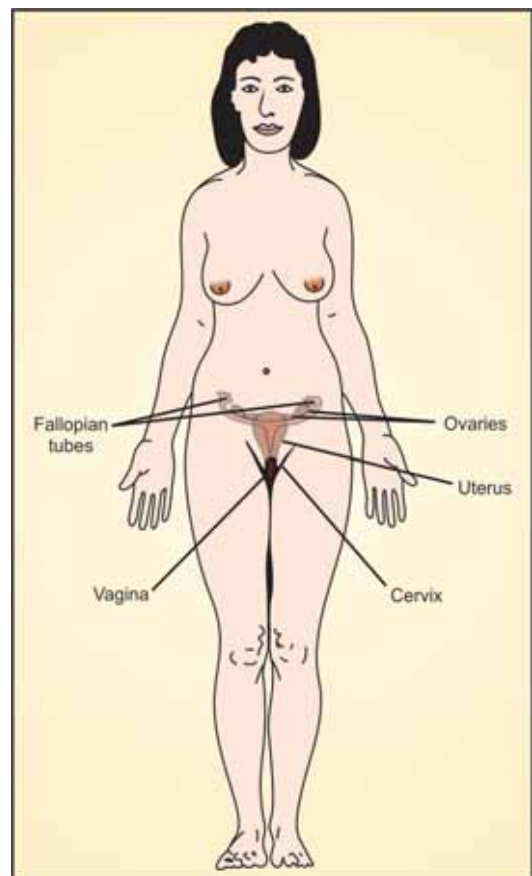


Fig. 24.2: Hair growth

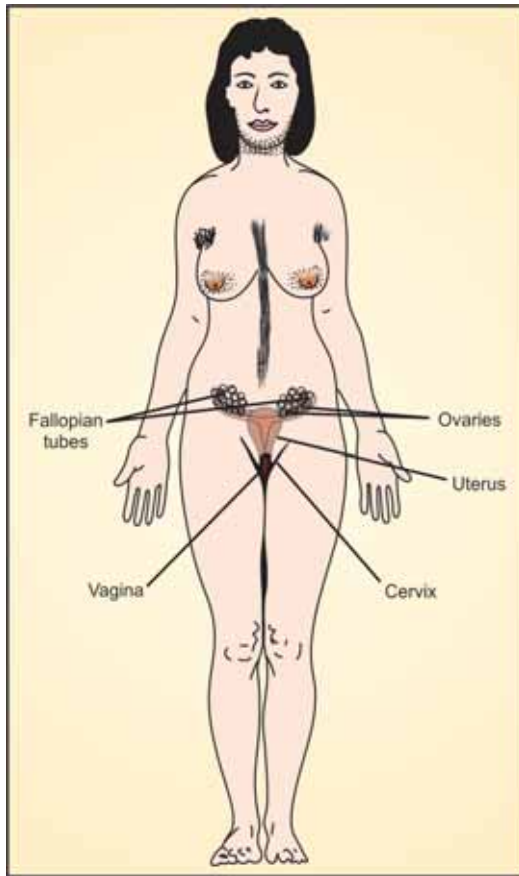


Fig. 24.3: Excessive hair growth

Testosterone is the most potent androgenic hormone. In women, testosterone is secreted in equal amounts from the adrenal glands and from ovaries, and these sources account for 50 per cent of the total testosterone found in the circulation. The remaining 50 per cent is produced by peripheral conversion of androstenedione, which is also secreted by the adrenal glands and ovaries. Normal circulating concentrations of testosterone in women range from 20 to 80 ng/dL. This range is far lower than the concentrations found in men, which range from 300 to 800 ng/dL. Approximately 80 per cent of testosterone is bound to sex hormone-binding globulin (SHBG). In women, approximately 19 per cent of the remaining testosterone is loosely bound to albumin, which leaves approximately 1 per cent in the free and active form.

Androstenedione is produced in equal amounts by the adrenal glands and the ovaries, and most of the androstenedione secreted is converted to testosterone. Androstenedione is a less potent androgen than

testosterone but can produce significant androgenic biological effects when present in excess amounts. Normal serum concentration of androstenedione in women ranges from 60 to 300 ng/dL.

Dehydroepiandrosterone (DHEA) and its sulfate (DHEAS) are androgen precursors produced almost exclusively by the adrenal glands. DHEA is metabolised quickly. As a consequence, measurement of its serum concentration does not reflect adrenal gland activity. DHEAS has a much longer half-life than DHEA, and measurement of its serum level is used to assess adrenal function. Levels of DHEAS in women vary widely, with a normal range of 38 to 338 µg/dL.

**Dihydrotestosterone (DHT):** Testosterone is converted to DHT by 5α-reductase, an enzyme found in many androgen-sensitive tissues such as skin. DHT is a very potent androgen and is primarily responsible for androgenic effects on hair follicles. Hirsutism in women with normal androgen levels may indicate increased activity of 5α-reductase.

Sex hormone-binding globulins (SHBGs). Because androgenicity is determined mainly by unbound testosterone, the circulating concentration of SHBG influences the hormonal state. Testosterone and insulin both decrease SHBG levels, whereas oestrogen and thyroid hormone increase its levels. Symptoms of hyperandrogenism may be seen in a patient with a normal total testosterone level if the level of SHBGs is decreased enough to significantly increase the free testosterone concentration.

### Causes of Hyperandrogenism

Five major causes of hyperandrogenism have been identified: hyperandrogenemic chronic anovulation syndrome, late-onset adrenal hyperplasia, tumors of the ovary or adrenal glands, Cushing syndrome, and idiopathic or drug-induced processes.

**A. Hyperandrogenic chronic anovulation syndrome:** In 1935 Stein and Leventhal described seven women who were amenorrhoeic, obese, and hirsute and who had cystic ovaries. From this initial description, the term Stein-Leventhal syndrome was used to identify other similarly affected women. Because of the cystic changes found within the ovaries of affected patients, the terms polycystic ovary syndrome (PCOS), and polycystic ovary disease (PCOD) were also used to describe these patients. However the new term is PCOS (details are in the chapter on PCOS).

- B. **Late-onset adrenal hyperplasia:** The most common adrenal enzyme defect is 21-hydroxylase (21-OH) deficiency. Deficiencies of 11 $\beta$ -hydroxylase and 3 $\beta$ -hydroxysteroid dehydrogenase are rarely seen. The 21-OH converts progesterone to deoxycorticosterone, or 17-OHP to deoxycortisol. A deficiency in the activity of this enzyme causes a decrease in cortisol production, which results in increased pituitary secretion of adrenocorticotrophic hormone (ACTH). Increased stimulation of the adrenal gland by ACTH may result in the production of increased amounts of the deoxycortisol precursor 17-OHP. Androstenedione is produced from 17-OHP by the enzyme 17 $\alpha$ -hydroxylase-17,20-desmolase. Androstenedione is in turn converted to testosterone by 17-ketosteroid reductase. Increased levels of 17-OHP result in increased secretion of androstenediol and testosterone from the adrenal gland. Elevated basal levels of 17-OHP and increased release of 17-OHP by the adrenal gland in response to ACTH stimulation are seen in patients with late-onset adrenal hyperplasia. In an anovulatory woman, basal levels of 17-OHP should be measured in the morning and should be less than 200 ng/dL. Levels exceeding 200 ng/dL require ACTH-stimulation testing. Patients with late-onset hyperplasia have 17-OHP levels higher than 1200 ng/dL in response to a 250 mg dose of ACTH after 1 hour. Only 3–5 per cent of hyperandrogenemic patients can be shown to have a partial deficiency in 21-OH. This percentage is approximately the same as the expected prevalence of partial 21-OH deficiency in the general population.
- C. **Androgen-producing ovarian or adrenal tumours:** Tumours of the ovary or adrenal gland that secrete androgens are quite rare. The presence of an androgen-producing tumour is suspected on the basis of clinical findings. Palpation of an adnexal mass in a patient with symptoms of hyperandrogenism or rapid onset of virilisation even in the presence of normal testosterone levels should prompt a workup for a pelvic tumour. Testosterone levels exceeding 200 ng/dL warrant concern about the presence of an ovarian or adrenal androgen-producing tumour. A concentration of DHEAS exceeding 1000  $\mu$ g/dL suggests the possibility of an adrenal androgen-producing tumour.
- D. **Cushing syndrome:** Patients with Cushing syndrome usually are identified easily by specific physical findings such as moon facies, increased nuchal fat (buffalo hump), abdominal striae, facial erythema,

and truncal obesity. This syndrome may result from excess levels of ACTH from a pituitary adenoma (Cushing disease), ectopic ACTH production, adrenal overproduction of cortisol, an ovarian tumour, or, rarely, ectopic production of corticotropin-releasing hormone. Increased 24-hour urinary excretion of free cortisol and inability to suppress fasting serum or plasma cortisol levels to less than 5  $\mu$ g/dL 12 hours after oral administration of 1 mg of dexamethasone are laboratory tests used to confirm the diagnosis of Cushing syndrome. Further studies including a high-dose dexamethasone suppression test and radiographic imaging are required to determine the cause of the disorder.

- E. **Idiopathic and drug-induced hirsutism:** Idiopathic hirsutism is diagnosed in individuals who are hirsute but who do not demonstrate abnormal findings on the standard laboratory tests ordered to identify known causes of hirsutism. Although estimates vary depending on the study cited, it is calculated that perhaps 5–15 per cent of all hirsute patients may have idiopathic hirsutism.

Because the presence of hirsutism is a biological manifestation of hyperandrogenism, the inability to identify a specific androgen that is elevated in patients with idiopathic hirsutism may simply reflect a lack of knowledge about the androgen responsible for the condition. An alternative explanation is based on the hypothesis that patients with idiopathic hirsutism demonstrate increased skin sensitivity to androgens. It has been suggested that patients with idiopathic hirsutism convert testosterone to DHT in greater quantities than normal due to increased activity of 5 $\alpha$ -reductase. Occasionally drug ingestion may be responsible for hirsutism. Danazol, a 17  $\alpha$ -ethinyl derivative of testosterone used for treatment of endometriosis, and methyltestosterone, used in hormone replacement therapy, are two examples of drugs that may cause iatrogenic hirsutism.

## DIAGNOSIS OF HYPERANDROGENISM

### History and Physical Examination

Hyperandrogenism may be diagnosed if biological signs of androgen excess are present. These signs include excessive sexual hair growth, male pattern baldness, deepening of the voice, enlargement of the clitoris, reduction in breast size, and male muscular development. A careful breast examination should be performed to look for galactorrhoea. Symptoms of a

thyroid disorder should be investigated. Signs of hyperinsulinaemia such as presence of acanthosis nigricans, should be sought.

### Laboratory Evaluation

Measurements of serum or plasma androgen levels may be obtained to diagnose hyperandrogenism. Testosterone and androstenedione levels are commonly measured. DHEAS levels should be determined to assess adrenal gland androgen production. Levels higher than 700 ng/dL are considered markers for abnormal adrenal function. Levels of 17 $\alpha$ -hydroxyprogesterone (17-OHP) should be determined. Levels of prolactin should be checked and thyroid function tests performed as well. The role of 17-OHP in the development of hyperandrogenism is described later in this chapter in the section on adrenal hyperplasia. Hyperprolactinaemia and thyroid disorders may produce hyperandrogenism directly by affecting androgen production and indirectly by creating an anovulatory state. Because hyperandrogenism and hyperinsulinaemia are often associated, a comprehensive workup includes assessment of insulin function. Diabetes mellitus may be excluded by determining that the fasting glucose level is lower than 116 mg/dL. Impaired glucose tolerance is indicated by a fasting glucose level of between 116 and 126 mg/dL. Diabetes is diagnosed by a fasting glucose level exceeding 126 mg/dL. A fasting glucose to insulin ratio of less than 4.5 is consistent with insulin resistance.

### Treatment

Treatment of the patient with hirsutism or hyperandrogenism depends on what the cause is and whether or not pregnancy is desired.

Treatment of patients with hyperandrogenemic chronic anovulation syndrome depends on their desire to conceive.

If pregnancy is not desired, therapy is directed toward stopping the development of new hair growth, removing existing excessive hair growth, and regulating the menstrual cycle. Hirsutism is slow to respond to hormone suppression, and results may not be seen for up to 6 months. In addition, previously established hair patterns do not change with androgen suppression. Mechanical methods of hair removal such as shaving, waxing, depilatories, and electrolysis should also be considered.

a. Oral contraceptive preparations (OCPs) diminish circulating gonadotropin levels and increase SHBG levels. Lowering of gonadotropin levels results in

decreased ovarian androgen secretion, which produces lower circulating levels of androgens. Increasing SHBG levels result in less free testosterone available for conversion to DHT in the hair follicle. Progestins also decrease activity of 5 $\alpha$ -reductase. Lowered total and free androgen levels in women treated with OCPs cause a reduction in the formation of new androgen-dependent hair growth and androgen-stimulated acne. All low-dose OCP preparations are believed to have similar results. However, one particular combination OCP (ethinyl oestradiol and norgestimate) has received Food and Drug Administration approval to be prescribed specifically for the treatment of acne. If therapy with OCPs is disappointing, addition of an antiandrogen such as spironolactone or finasteride is recommended.

Newer OCP's with cyproteroneacetate and drospirenone have a good antiandrogenic effect and are helpful in managing hirsutism. Cyproterone acetate pills are better as they have more antiandrogenic activity than drospirenone (30%).

- b. *Medroxyprogesterone acetate*: If combination OCPs are contraindicated or not desired, medroxyprogesterone acetate given as 10 mg for 10–12 days every month or every other month may be used to produce regular withdrawal bleeding to reduce the risk of menorrhagia or endometrial hyperplasia or both. Patients should be cautioned that, unless contraception is used, pregnancy is possible with cyclical progestin therapy.
- c. Spironolactone therapy is often initiated if OCP use is not an option for treatment of hirsutism or if results from OCP therapy are not optimal. An aldosterone antagonist, spironolactone is a steroid compound originally dispensed as an antihypertensive agent. Its activity as an antiandrogen was detected after men receiving the compound developed gynaecomastia. It is now known that spironolactone inhibits the binding of DHT to its receptor and directly inhibits 5 $\alpha$ -reductase. Spironolactone also decreases androgen synthesis by inhibiting 17 $\alpha$ -hydroxylase and 17, 20-lyase. After 6 months of therapy at 100–200 mg/day, reduction in the diameter of terminal hair and cessation of new terminal hair growth are observed. Doses may be tapered down to a maintenance dose of 25–50 mg/day. Because of potential adverse effects on the development of the external genitalia of male fetuses, spironolactone should be used together with contraception in sexually active women. Side effects include diuresis,



fatigue, dysfunctional uterine bleeding, hyperkalemia, and breast enlargement.

- d. Flutamide is a nonsteroidal antiandrogen that blocks the binding of androgen to its receptor. It was developed initially for the treatment of prostate disease. When administered in a dosage of 250 mg/day, decreased terminal hair diameter and cessation of new hair growth are observed. Side effects include dry skin and a rare but severe hepatotoxicity. Liver function should be monitored. During pregnancy, flutamide may have a detrimental effect on male foetal development. Therefore, concurrent therapy with OCPs or other contraception is encouraged.
- e. **Finasteride:** An inhibitor of type II  $5\alpha$ -reductase, finasteride was developed initially as a treatment for prostate hypertrophy and cancer. By inhibiting  $5\alpha$ -reductase, the drug decreases DHT activity at the hair follicle. Two types of  $5\alpha$ -reductase enzyme activity exist, type I and type II. Although finasteride treatment prevents new hair growth and decreases the terminal hair shaft diameter, it does not appear to completely inhibit type I  $5\alpha$ -reductase, which is present in skin. Finasteride is orally dosed at 5 mg daily. As of yet, no major side effects have been associated with this drug. There is potential risk during pregnancy as DHT participates in the development of male external genitalia. Adequate contraception should be used. Finasteride is also available in a lower-dose preparation, 1 mg (Propecia), and has been approved for the treatment of hair loss in men.

If pregnancy is desired by individuals with hyperandrogenic chronic anovulation syndrome, assistance with ovulation induction frequently is required.

- f. Cosmetic treatment of hirsutism is useful when permanent hairs have grown (Fig. 23.4).

### LATE-ONSET ADRENAL HYPERPLASIA

Individuals diagnosed with late-onset adrenal hyperplasia may be treated by administration of glucocorticoid agents to restore ovulation. This treatment also reduces circulating androgen levels. Glucocorticoid administration is therefore appropriate therapy for infertility or hirsutism in individuals with late-onset adrenal hyperplasia. In patients with 21-OH deficiency, prednisone, 5 mg before bedtime, is used to suppress endogenous ACTH. Alternatively, the same hormone therapy indicated for individuals with hyperandro-



Fig. 24.4: Cosmetic treatment of hirsutism

genic chronic anovulation may be used in individuals with late-onset adrenal hyperplasia. OCPs or antiandrogens may be used successfully to treat hirsutism, alone or in combination with dexamethasone. Ovulation-inducing drugs may also be used to treat infertility.

### Androgen-producing Ovarian or Adrenal Tumours

Androgen-producing ovarian or adrenal tumours usually are treated surgically. Depending on the type of tumour, additional treatment with chemotherapy or radiation therapy may be required.

### Cushing Syndrome

Surgery of the pituitary or adrenal gland may be required to treat Cushing's disease or adrenal hyperplasia causing Cushing's syndrome.

### Idiopathic Hirsutism

The same medications used to treat hirsute patients with hyperandrogenic chronic anovulation may be used to treat patients with idiopathic hirsutism. Hyperinsulinaemia. Hyperandrogenism has been associated with hyperinsulinaemia and insulin resistance. Insulin resistance is defined as a reduced glucose response to a given amount of insulin. Acanthosis nigricans is a gray-brown velvety discolouration of the skin and is a reliable indicator of insulin resistance and hyperinsulinaemia. It is often seen in obese patients with hirsutism and is usually found in the groin, neck, axilla and vulva.

# CHAPTER 25

## Epithelial Abnormalities of the Genital Tract

Vulva	400
Vagina	409
Cervix	410
Uterine Corpus	422
Fallopian Tube	426

The clinical and histological appearances of the various parts of the genital tract can vary considerably, although in many instances, the pathological changes are part of a continuing process. In some cases this process may be reversible, in others it may be static, while in some it may be irreversible and the possibility of malignant change increased (Figs 25.1 and 25.2A to D).

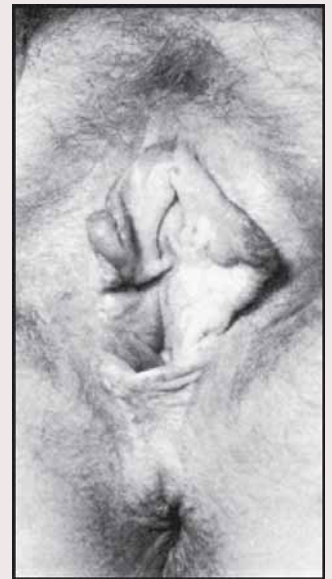
### VULVA

The skin of the vulva is commonly the site of chronic and resistant changes, the pathogenesis of which is obscure. Comparable changes are seen in the male and affect the scrotum and phallus. They have been the source of confused literature, views and nomenclature.

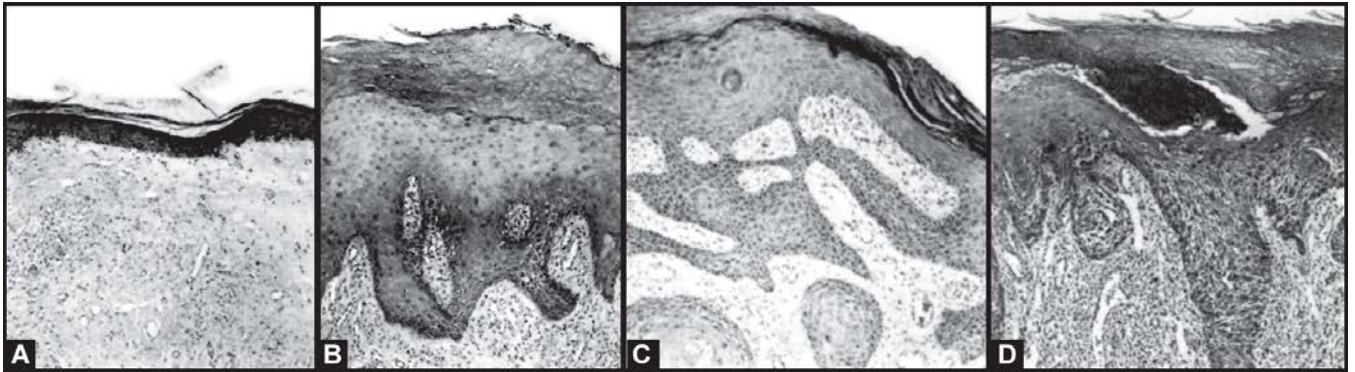
### Pathology

Epithelial abnormalities of the vulva may appear clinically as white patches or plaques (so-called *leukoplakia* from the Greek *leuco* = white and *plax* = a flat plate), as reddened areas, or as a combination of both. The naked eye appearances give little clue (Fig. 25.3) to the underlying histological features and yet it is these which will determine the outcome. The term *leucoplakia*, which is commonly used to describe the clinical appearance of the vulva should not be used as a definitive diagnosis. It is imprecise and as such may be easily misinterpreted.

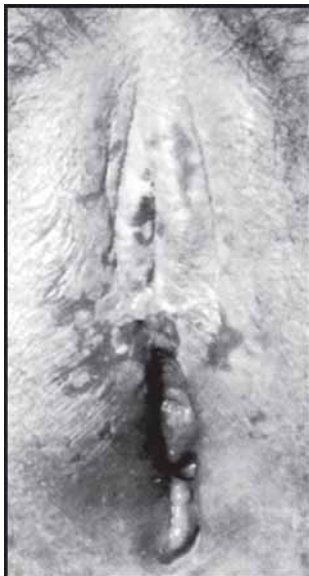
To avoid this ambiguous term, Professor Jeffcoate in 1966 introduced the term *dystrophy* into the nomenclature of benign vulvar epithelial



**Fig. 25.1:** A hyperkeratotic form of chronic vulvar epithelial disorder, the classical appearance of what in the past was called clinical leukoplakia. This vulva on section showed in different areas histological appearances varying from atrophic epithelium to invasive cancer (see Fig. 25.2)



**Figs 25.2A to D:** Varying histological appearances in different parts of the vulva shown in Fig. 25.1. (A) An atrophic but hypertrophic epithelium with subepithelial degenerative changes and hyalinisation. The picture is typical of lichen sclerosus. (B) This area shows hyperkeratosis and a thicker acanthotic epithelium, (C) A higher-power view showing epithelial cells exhibiting pleomorphism, lack of orientation and atypia; a picture of vulvar intraepithelial neoplasia (VIN). (D) This field shows changes indicative of invasive squamous carcinoma



**Fig. 25.3:** A chronic vulvar epithelial disorder showing hyperkeratosis and contracture around the clitoris and the foreparts of the vulva. Elsewhere the skin is atrophic. Patchy ulceration from scratching is shown. This appearance might, in the past, have been described as atrophic leucoplakia, kraurosis or primary atrophy

lesions. The term dystrophy is no longer used either. The epithelial abnormalities which are characterised by epithelial growth and maturation are now grouped together under the general term ‘non-neoplastic epithelial disorders of skin and mucosa’ at the recommendation of the International Society for the Study of Vulvar Disease (ISSVD) (Table 25.1).

### Senile Atrophy

Atrophy and shrinkage of the labia in old age, with some contracture of the introitus, is a normal physiological change attributable to withdrawal of the hormone influences of the ovary and adrenal. The histological features are those indicative of atrophy of the epidermis and dermis. Except that it causes dyspareunia, senile atrophy of the vulva, usually associated with a similar change in the *vagina*, is symptomless.

### Lichen Sclerosus

Lichen sclerosus is the commonest white lesion of the vulva. It is most often seen in postmenopausal women. It appears as white, glistening sheets with clearly defined

**Table 25.1: Classification of Epithelial Vulvar Diseases (ISSVD 1989)**

- *Non-neoplastic epithelial disorders of the skin and mucosa*
  - Lichen sclerosus (formerly hypoplastic dystrophy)
  - Squamous cell hyperplasia (formerly hyperplastic dystrophy)
  - Other dermatoses
- *Mixed non-neoplastic and neoplastic epithelial disorders*
- *Intraepithelial Neoplasia*
  - Squamous intraepithelial neoplasia*
    - VIN I
    - VIN II
    - VIN III
  - Non-squamous intraepithelial neoplasia*
    - Paget's disease
    - Tumours of melanocytes, non-invasive
- Invasive tumours

margins and involves the labia, the perineum and the perianal region. The labia minora are adherent to the labia majora, the clitoris is buried and the introitus shrinks. Although the epithelium is not thickened, the naked-eye picture clearly resembles that of what is often called leukoplakia; an alleged difference is that leukoplakia does not extend around the anus.

Histologically, lichen sclerosus shows not only a thin and inactive epithelium, but also hyperkeratosis, loss of elastic tissue, hyalinisation of the collagen layer and subepithelial infiltration with leucocytes. Extravasated red cells are commonly seen.

Some say that lichen sclerosus can transform to intraepithelial neoplasia and this in turn to cancer; the majority, however, take the view that lichen sclerosus is never a forerunner of malignant change.

Skin which shows gross injury — with excessive keratinisation and destruction of the dermis — may have reached a stage from which recovery is impossible. This change may represent a permanent degree of damage from ischaemia. Indeed, the development of male and female genital 'leucoplakia' to a stage of irreversibility has been studied in cases of aribo-flavinosis occurring in the tropics.

### Aetiology

Familial incidence is well recognised and may involve both sexes, e.g. a father and a daughter. It has also been seen in identical and non-identical twins.

The unusual character of the skin changes in non-neoplastic epithelial disorders is probably explained by environmental factors. The skin in other sites exposed to warmth and moisture tends to react in a similar way. The lesions produced by fungus and other infections between the toes and around the arms closely resemble those of clinical leukoplakia. The mouth and tongue have a similar environment and suffer similar diseases variously described as leukoplakia and lichen. Skin anywhere can be made 'leucoplakic' by exposure to warm wet poulticing. Finally, it has been shown that grafts of skin from an extragenital site, when used to cover the raw area after vulvectomy for epithelial disorders, often develop the disease. Even more important, abnormal skin transplanted from the vulva to an extragenital site can spontaneously return to normal.

The factors that initiate changes in the vulvar skin are not known for certain, but investigations and

therapeutic trials indicate the following possibilities. Some of these are discussed elsewhere which should be read in conjunction with this.

### *Chronic Mechanical Irritation*

Constant scratching and rubbing produce lichenification of the skin, the appearances of which are quite different from those of any of the epithelial abnormalities. Although a scratch habit can produce local injury and even neurodermatitis, it is not the cause of an epithelial abnormality. It is the epithelial abnormalities which makes a woman scratch, not the reverse, and the resulting lesions are easily distinguished.

### *Deficiency States*

Various external genital epithelial disorders (in males and females) can accompany states of deficiency in iron, folic acid, vitamin B<sub>12</sub>, riboflavin, and possibly other essential factors. Thus they are seen in cases of anaemia and pellagra. The deficiency can arise from errors in diet, as in the case of the elderly living alone. They can also result from malabsorption syndromes, achlorhydria and chronic diarrhoea.

### *Autoimmunisation*

A weak link with autoimmunisation is established. Twenty-one per cent of patients have an autoimmune disease, 22 per cent a family history and 44 per cent have one or more antibodies in significant concentration.

### *Metabolic Upsets*

Diabetes mellitus, in addition to causing diabetic vulvitis, is sometimes associated with leucoplakic changes in the vulva.

### *Infection*

Many women with epithelial abnormalities have evidence of fungus infection elsewhere, on the hands and feet particularly (Fig. 25.4). Digital lesions are rarely caused by *Tinea*, more often by *Candida* or *Corynebacterium minutissimum*. Vulvar and vaginal candidiasis is often demonstrable by culture. Whenever the perianal skin is involved, an alimentary or local fungus infection should be presumed. Sometimes it is the patient's husband who has 'athlete's foot' or some other fungal lesion.



**Fig. 25.4:** A chronic interdigital infection (? fungus) associated with a chronic vulvar epithelial disorder. The photograph shows the space between two toes, these being held apart by the examining fingers. The skin is hyperkeratotic, sodden, cracked and peeling, producing a lesion very similar in appearance to the one on the vulva. This sort of condition is commonly found in women suffering from vulvar and perianal epithelial changes and pruritus

That candidiasis can cause hyperkeratotic skin abnormalities is well shown by the fact that *Candida balanitis* in the male can result in leucoplakic or lichen-like lesions on the glans penis which persist for weeks despite applications of fungicides. In the case of *Tinea pedis* infections, the associated vulvar epithelial disorder is more likely to represent an epidermo-phytoid reaction than a spread of the fungus to the vulva.

The spirochaete *Borrelia burgdorferi* was implicated in the causation of lichen sclerosus but this has not been fully substantiated.

### Symptoms

Some epithelial abnormalities are symptomless and progress insidiously for many years without the patient's knowledge. Usually they cause pruritus which is intense and persistent. When the skin cracks, or is broken by scratching, it becomes secondarily infected and painful. Dyspareunia can result from this or from contracture of the introitus. The average age at which the patient presents for treatment is 45 years. Nevertheless, vulvar epithelial disorders, and especially lichen sclerosus, are

described in childhood when they may or may not cause itching. These usually undergo spontaneous cure at puberty.

### Diagnosis

Non-neoplastic epithelial disorders have to be distinguished from *leucoderma*, a condition of patchy depigmentation of otherwise normal skin. More clearly defined skin diseases such as psoriasis have also to be excluded.

The first step in the investigation of a non-neoplastic epithelial disorder is to take portions of affected skin from several sites for histological examination. This is primarily to exclude vulvar intraepithelial neoplasia (VIN), invasive cancer and epithelial activity which carry a threat of cancer in the future. It may also sometimes distinguish the vulvar lesion from a recognised skin disease such as psoriasis. Biopsy is essential in all long-standing lesions, irrespective of their appearance. It is best taken with the 4 or 6 mm Keyes punch under local anaesthesia. Knife biopsies tend to be tangential and often do not reach the deeper layers.

The second step is to attempt to determine a possible underlying cause of the abnormality; the more carefully this is done the more likely it is to be successful. Attention should be paid to the points already mentioned under aetiology while taking the history. Full physical examination should include a search for extragenital lesions, especially in the mouth and ears, and on the hands and feet. The appearance of the vulva itself is not particularly diagnostic. The skin may be white or red or both in patches; it may be thin or thick. Special investigations to be performed in all cases are: repeated examination of vaginal and vulvar swabs for *Trichomonas vaginalis* and *Candida albicans*; examination of the blood; tests for achlorhydria; glucose tolerance test; tests for folate and vitamin B<sub>12</sub> deficiencies; and skin sensitivity tests.

### Treatment

Treatment depends on the cause and on whether biopsy reveals VIN or epithelial atypia which carries a threat of cancer.

#### General Treatment

It is important to prevent the patient scratching and to ensure sleep by giving sedatives, if necessary. During

the day, cold cream applications or washing with 1 per cent sodium bicarbonate can provide temporary comfort. The vulva should be kept cool and free from sweat by the wearing of loose and light cotton underclothing. Nylon and similar materials should be banned. At night, a free circulation of air to the vulva should be ensured by supporting the bed clothes with a cradle.

#### *Medical Treatment of the Cause*

Treatment is directed primarily to eliminating any aetiological factor discovered. Anaemia is corrected, folic acid or vitamin B<sub>12</sub> administered if a deficiency is present, glycosuria controlled, candidiasis eradicated and proven antigens avoided. Fungus infections of the feet of either the patient or her husband are treated with fungicides.

When a possible cause is not found, as happens in at least 50 per cent of cases, empirical treatment becomes necessary.

### **Empirical Measures**

#### *Corticosteroids*

Clobetasol propionate 0.05 per cent ointment is the definitive treatment of lichen sclerosus. Its safety and efficacy have been documented in a dose not exceeding 30 g over a period of 3 months. The skin immune response and reversal of squamous hyperplasia has been demonstrated in biopsies of treated patients. Monitoring is important. Response is usually sustained. A combination of steroid with antibacterial agents may be required in cases with secondary infection. Treatment may need to be continued for 6-12 months in some patients. After completion of therapy, an emollient cream may be applied regularly.

#### *Oestrogens and Testosterone*

Oestrogen therapy only helps to clear up secondary infection of the vulva in postmenopausal women.

Testosterone propionate 2 per cent in petrolatum was considered standard treatment for lichen sclerosus, applied twice daily for 3-6 weeks and then once or twice a week. However, nearly 70 per cent of patients have been found to discontinue therapy because of lack of response as compared to only 10 per cent with clobetasol propionate. Even when a response does occur, it is not sustained if therapy is discontinued. Overdosage can result in virilisation.

#### *Local Analgesia*

Anaesthetic ointments containing procaine or similar agents should *never* be used; they give little symptomatic relief and very often produce severe local reactions. The local injection of anaesthetic solutions is also best avoided; it involves a high risk of abscess formation and does not usually improve symptoms.

#### *Division of Cutaneous Nerves; Nerve Block*

Division of all the cutaneous nerves by a circular incision around the vulva gives relief; the effect usually only lasts for 3-6 months but occasionally, and perhaps because it breaks a scratch habit, it is permanent.

Multiple injections of absolute alcohol, presumably to block or damage cutaneous nerves, have been advocated but are rarely effective in the long term.

#### *Vitamins*

Large doses of vitamin A or riboflavin can be given orally or by injection. The results are unsatisfactory except when a deficiency state is proven. Atretin and etretinate have been effective orally. However, they have significant side-effects.

#### *Fungicides*

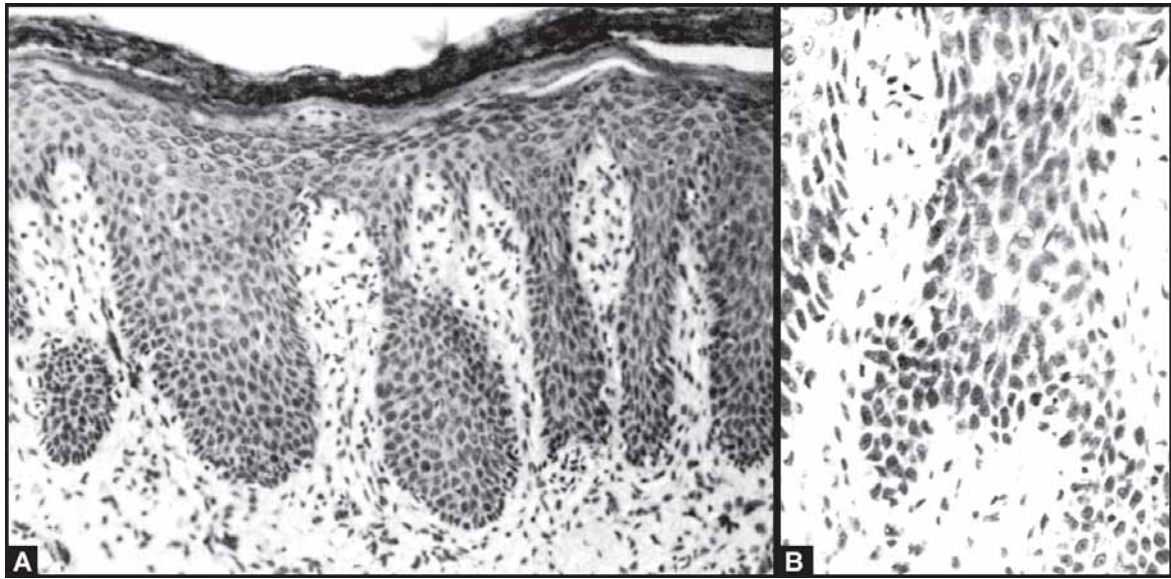
Whenever a lesion is associated with evidence of an extragenital fungus infection, applications of fungicidal ointments to the vulva are worth trying and can have good results.

#### *Other Local Applications*

When the skin is hard and tends to crack, emollient applications to the vulva help. Examples are crude cod liver oil, an emulsion of equal parts of lanoline and arachis oil and a cream made up of zinc oxide (40 parts) and olive oil (60 parts).

Whatever treatment is applied, *every patient suffering from an epithelial disorder requires continuous supervision for an indefinite period.* If the lesion persists or recurs, further biopsies at intervals are required to exclude the possibility of changes in epithelial activity, if not cancer (Figs 25.5A and B).

One of the remarkable things revealed by late follow-up is that sometimes when a patient, after years of misery, abandons all hope of cure and all treatment, a longstanding epithelial disorder *disappears spontaneously.*



**Figs 25.5A and B:** Moderate vulvar intraepithelial neoplasia (VIN II). (A) There is a layer of keratin on the surface and the underlying epithelium shows a disturbance of normal stratification, which is most severe in the basal two-thirds of the epithelium, (B) A high-power photomicrograph shows mitotic figures as well as hyperchromatic nuclei and pleomorphism. Hence the necessity for mandatory multiple biopsies when a vulvar epithelial disorder is present

### *Vulvectomy*

When a non-neoplastic epithelial disorder is localised, local excision or partial vulvectomy may be the best method of biopsy. Otherwise vulvectomy should be reserved mainly for those cases in which atypical epithelial activity is found histologically (Fig. 25.5). In these cases it is clearly indicated and need not be accompanied by lymphadenectomy.

Whenever vulvectomy is performed, it should be followed by treatment of any aetiological factors revealed by investigation, and by regular supervision of the patient for an indefinite period. Invasive carcinoma can supervene despite vulvectomy.

If there is no threat of cancer, empirical vulvectomy should be avoided. It is mutilating and gives poor results. The disorder recurs sooner or later in 50 per cent of cases treated by vulvectomy, and in skin which, had it been left in its normal site (well outside the labia), would not have become affected (Fig. 43.4). There is no role of vulvectomy in children with lichen sclerosis.

### **Vulvar and Oral Epithelial Abnormalities**

Traditional leucoplakia of the vulva is often regarded as being a disease different from leucoplakia of the buccal

cavity and tongue. Clinical leucoplakia of the external genitalia is rarely seen in conjunction with oral leucoplakia in the same individual, male or female. Nevertheless, there are some extraordinary bonds between these two areas of the body. Both are erogenous zones; both are common sites for fungal infection; both are subject to recurrent (cyclical) ulceration; and both show epithelial changes in deficiency states such as anaemia and ariboflavinosis.

### **Vulvar Intraepithelial Neoplasia**

#### *Incidence and Aetiology*

Vulvar intraepithelial neoplasia (VIN) is now being discovered with increasing frequency and this may be the result of the modern practice of submitting non-neoplastic epithelial disorders to biopsy, which is the means of bringing most cases to light. The increase appears to be among young, rather than old, women. In 40 per cent of reported cases the patients were less than 40 years of age. It is suggested that the modern involvement of the young is related to their acquiring sexually transmitted virus and other infections. In particular, the human papillomavirus is postulated as a causal agent. It is also seen more commonly in smokers.

**Pathology**

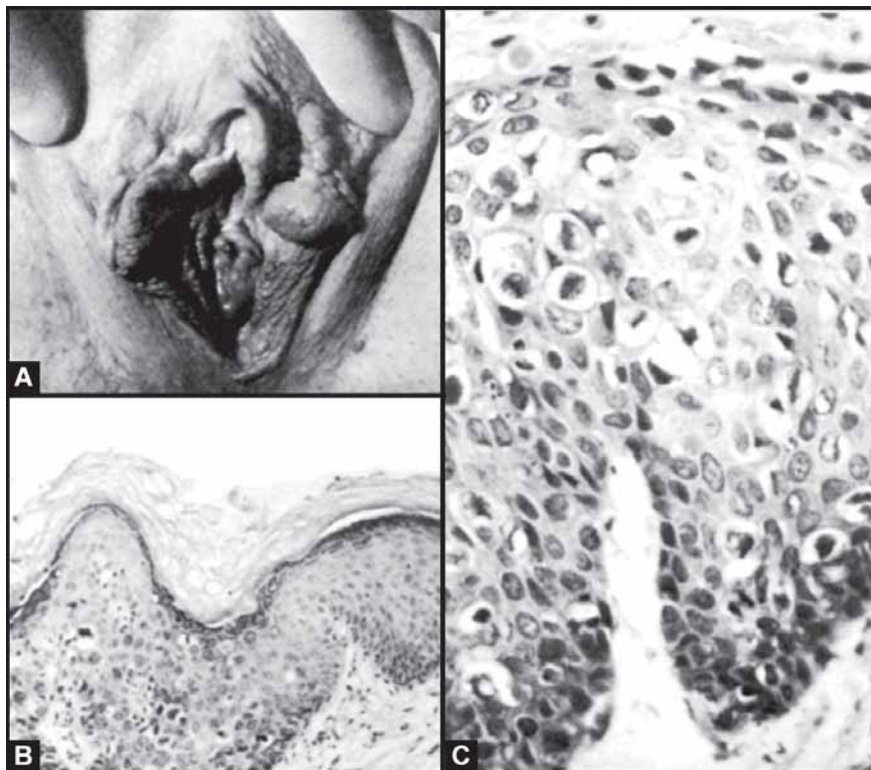
The diagnosis is essentially a histological one and the microscopic patterns fall into two main groups, these in the past having been regarded as separate diseases (Table 25.1).

*Squamous Intraepithelial Neoplasia*

The pattern here is similar to that of dysplasia or *in situ* squamous cell cancer in any site. Depending on whether the lesion is VIN I (mild dysplasia), VIN II (moderate dysplasia) or VIN III (severe dysplasia or carcinoma *in situ*), changes are seen predominantly in the lower one-third, two-third or the whole thickness of the epidermis, respectively. The cells have malignant characteristics, showing pleomorphism, large irregular and hyperchromatic nuclei and mitotic activity. There is a disorderly arrangement of the cells with loss of stratification.

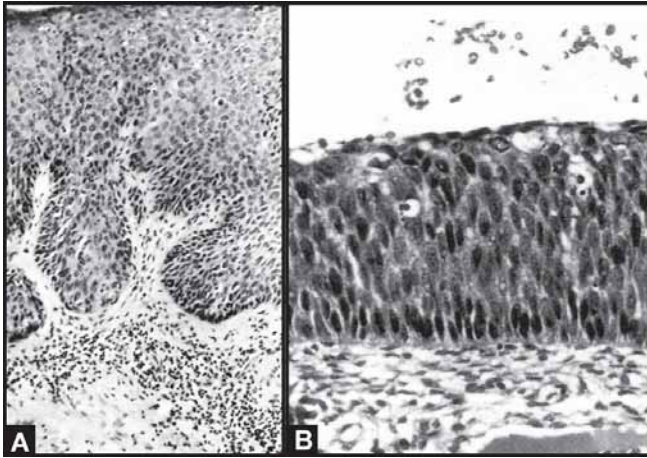
Hyperkeratosis and parakeratosis are variable findings (Figs 25.6A to C and 25.7A and B).

An essential feature is failure of the cancer cells to penetrate the basement membrane. As in the case of the same condition in the cervix, a stage of *microinvasion* is described but is more closely related in behaviour to an invasive carcinoma. The term 'Bowen's disease' has often been applied to some cases of intraepithelial neoplasia when large bloated 'Bowen's cells' and sometimes 'corps ronds' appear amongst the ordinary cancer cells. The former are large cells showing perinuclear vacuolation and nuclear fragmentation; the latter have small hyperchromatic nuclei and a cytoplasm which stains deeply with eosin. These features, also sometimes found in skin cancers in other sites, were once thought to denote a specific disease. It is now recognised that the large cells represent nothing more than malignant epithelial cells which have undergone degenerative change and nuclear



**Figs 25.6A to C:** Vulvar intraepithelial neoplasia (VIN III) of the vulva in a woman aged 35 years who had had pruritus for 5 years. Originally she was treated for proven *Trichomonas* and *Candida* infection with improvement in symptoms; 3½ years later she returned and the vulva was then rather pale and thickened with one hyperkeratotic plaque which lies medial to the examiner's thumb and condylomatous areas in (A), (B) Photomicrograph of a biopsy specimen showing the junction of hyperkeratotic epithelium and a focus of Bowenoid VIN III. The epithelium shows loss of stratification, and pleomorphic cells with hyperchromatic nuclei, mitotic figures and koilocytes. (C) A higher-power view to emphasize these features. Subsequent simple vulvectomy revealed multiple abnormal foci scattered throughout the vulva on both sides, even in completely normal-looking skin





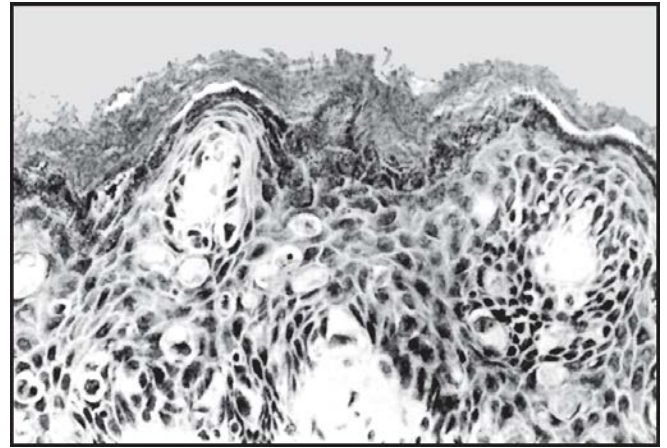
**Figs 25.7A and B:** Vulvar and cervical intraepithelial neoplasia in the same woman who was aged 47 years. She had no complaints but had a routine cervical smear when she attended a special clinic and was also noted to have one small pale area on one labium. When the diagnosis was established she was treated by cone excision of the cervix and simple vulvectomy. (A) VIN III: One of the many separate foci found throughout the vulva, (B) CIN III: The entire thickness of the epithelium is occupied by darkly staining, hyperchromatic cells with high nucleocytoplasmic ratios and there is no normal stratification. These are separate lesions but they commonly coexist. Intraepithelial or invasive carcinoma of the cervix or vagina or both is found in 20-25 per cent of cases of VIN, reflecting a field change

clumping, and there is therefore no need to continue using the term 'Bowen's disease' of the vulva. It is a pattern of VIN found in association with human papillomavirus infection, usually type 16.

VIN occurs by itself but is sometimes a histological finding alongside invasive carcinoma in about 20-30 per cent of cases. VIN III can progress to invasive cancer in less than eight years, the incidence being significantly higher in untreated than in treated cases (87.5% versus 3.8%).

#### Paget's Disease

Paget's disease of the vulva is a non-squamous intraepithelial neoplasia associated with proliferation of atypical glandular cells of the apocrine type. In this condition the epidermis contains large secretory cells arranged singly or in groups, often called 'Paget's cells'. Their nuclei are polymorphic and hyper-chromatic; their cytoplasm is pale and vacuolated and contains a mucopolysaccharide (mucin) similar to that normally



**Fig. 25.8:** Paget's disease of the vulva. The section is from an extensive red lesion affecting the introitus of a multiparous woman. The lesion, which is an epithelial adenocarcinoma, recurred after repeated excision during 10 years without ever becoming invasive. In contrast to Paget's disease of the breast, where an underlying carcinoma is the rule, in only about 30 per cent of cases of vulvar Paget's disease is an underlying invasive neoplasm identified. Large Paget's cells with clear cytoplasm which were positive for mucin can be seen within the epidermis

secreted by apocrine glands (Fig. 25.8). This shows up with special stains such as PAS. It was once believed that Paget's disease of the vulva was similar to Paget's disease of the nipple in that the special cells are migrants to the epidermis from an underlying or neighbouring adenocarcinoma. Only 30-40 per cent of cases of Paget's disease of the vulva are associated with an adnexal carcinoma. The remainder are intraepithelial neoplasms and the behaviour and treatment of the two groups are therefore different. Paget's disease tends to recur, not necessarily because it is multifocal but because it is an *in situ* change and because excision is difficult as the edges are ill-defined and the cells extend beyond the apparent clinical limits. So Paget's disease of the vulva is nothing more than a variant of vulvar intraepithelial neoplasia.

#### Clinical Features

VIN occurs at any age. It is not infrequently associated with a past or present history of intraepithelial neoplasia or invasive cancer, of the vagina or cervix or both. This must reflect widespread epithelial unrest affecting the whole lower genital tract ('field change'). In keeping with this idea is the fact that the lesions on the vulva are often multifocal.

The patient may complain of pruritus vulvae or slight soreness; she is sometimes aware of a change in colour or consistency of the skin. VIN I is never visible macroscopically while higher grades are nearly always visible. Characteristically, the lesion appears as a bright scarlet, slightly raised, velvety plaque with clearly defined serpiginous edges. This can be a feature of any of the histological types of the disease but is especially likely with Paget's disease. It explains why carcinoma *in situ* was sometimes called *erythroplasia of the vulva* and in practice, care is necessary to distinguish the disease from psoriasis.

Although this is the classical picture, the affected skin can look completely normal, brownish, thickened or white and hyperkeratotic (Fig. 25.6).

VIN can arise in any part of the vulva but is mostly found around the introitus. From there it may spread internally to involve the urethral meatus and laterally to the skin of the groins. It is also not uncommon to find the perineal and perianal areas implicated, without much in the way of macroscopic skin change.

### Diagnosis

The diagnosis can only be made by histological examination of excised tissue. Cytology for diagnostic or follow-up purposes is generally useless; the cancer cells are not desquamated and are rarely picked up in scrapings of the skin. Areas likely to be affected may be identified by their staining reaction to nuclear stains, specifically 1 per cent toluidine blue and tetracycline fluorescence, which make areas of increased metabolic activity show up. However, the test is of limited value, being non-specific and unreliable. Colposcopic assessment is of limited value as a screening procedure in demarcating areas before conservative surgery.

If there are multicentric lesions, a skinning vulvectomy with or without skin grafting can be done. In this procedure, the involved skin is excised leaving the subcutaneous tissue intact. A split-thickness skin graft taken from the buttocks or from the inner aspect of the thigh may be substituted in its place. This procedure gives excellent cosmetic and functional results. Recurrences of VIN usually occur in the remaining areas of original vulvar skin and are seldom seen in the grafted area. Results are satisfactory in most patients, even without grafting.

The skinning vulvectomy and skin graft procedure requires bed rest for a week, with its consequent potential

for morbidity. In the elderly patient, therefore, a simple vulvectomy may be preferred. This also takes into account the likelihood of multiple microscopic foci, but does not guarantee against future recurrence.

Destructive therapy using electrocautery, cryotherapy and laser ablation has been tried. This treatment leaves behind a painful ulcer which may take up to three months to heal. The best results are with the CO<sub>2</sub> laser but great expertise is required to control the depth of destruction. This depth should be <1 mm in non-hairy and 3 mm in hairy areas. General anaesthesia may be required for large lesions. Post-laser management includes keeping the vulva clean and dry (a hair drier is recommended for this purpose); local application of topical steroids; analgesia—the severest pain occurs 3-4 days post-operatively.

Before treatment, the patient should be told about the possibility of recurrence. She should also be informed about the future risk of invasive cancer and the importance of life-long follow up. Recurrence occurs in 20-30 per cent of cases.

### Treatment

There is no need for a radical approach to this disease. Ordinarily the best treatment of a clearly defined lesion is by wide local excision of the affected area with at least a 5 mm margin of normal skin with end-to-end approximation of the deficit.

In Paget's disease, simple vulvectomy is the treatment of choice. Laser therapy is not advocated as it is important to remove the dermis as well and evaluate it histologically to rule out adenocarcinoma.

The Cavitron Ultrasonic Surgical Aspirator (CUSA) has been used in condylomata and in VIN but large-scale studies are awaited.

In young patients, sometimes nothing more than regular supervision is called for. In mild cases, spontaneous cure can be an outcome, but close follow up is essential.

Topical 5-fluorouracil has been used but is painful and ineffective. Topical gamma interferon may give better results. Radiotherapy is not indicated.

Recurrences of VIN are common but these probably represent new lesions arising in an unstable epithelium. These may require repeated excision over the course of many years.

Although VIN always carries a threat of invasive cancer, this rarely develops. However, *microinvasive lesions should always be regarded as invasive cancer*.

## VAGINA

Epithelial abnormalities of the vagina are rare. *Basal cell hyperplasia*, hyperplasia and vaginal intraepithelial neoplasia (VAIN) of the squamous epithelium can occur in single or multiple patches, in any site.

The first is usually regarded as a reactive response to inflammation; the latter is often associated with intraepithelial neoplasia or invasive cancer of the cervix or vulva, and then represents not extensions of these conditions but independent lesions which reflect a widespread epithelial unrest affecting the whole of the lower genital tract. These epithelial abnormalities are symptomless and the affected epithelium may look normal to the naked eye. Occasionally they cause red patches on the vaginal wall and often they can be identified by a negative Schiller's iodine test or colposcopy.

### Vaginal Intraepithelial Neoplasia (VAIN)

#### *Pathology and Aetiology*

Vaginal intraepithelial neoplasia can have a localised or patchy distribution in the vagina, be extensions of cervical intraepithelial neoplasia (CIN) or be associated with similar but separate lesions on the cervix or vulva. Human papillomavirus (HPV) infection may occur by way of abrasions from coitus or from tampons. In such a situation, the abrasion heals with metaplastic squamous cells which are similar to the immature epithelial cells of the transformation zone and HPV may begin its growth here. It may, rarely, be seen many years after radiotherapy for cervical carcinoma. Its histological features are the same as those of CIN. Untreated, or inadequately treated, VAIN may progress to invasive cancer in about 3 per cent of cases.

#### *Clinical Features*

To the naked eye the disease may appear as discrete red areas but often the epithelium looks normal. In the latter case, the lesion is then only discovered accidentally or as the result of routine vaginal cytology or colposcopy examination especially with associated CIN. Its site may be revealed by failure of the epithelium to stain brown with Lugol's iodine.

#### *Treatment*

The treatment of VAIN varies with the circumstances. A clearly defined lesion can be excised or treated by laser

vaporisation. Since the disease is often multi-focal, adequate surgery may involve total vaginectomy. In the majority of cases, especially in relatively young women, this is unnecessarily radical. In these, and if the disease is symptomless, no treatment other than regular colposcopy assessment is usually indicated. When treatment is required, the possibilities include local excision, cryotherapy, laser therapy, topical 5-fluorouracil and intravaginal irradiation.

### Vaginal Adenosis

*Adenosis* of the vagina is a very unusual condition in which columnar epithelium, sometimes multi-layered, replaces the squamous lining. It has a patchy distribution, the affected areas having a dull red granulomatous appearance and failing to stain with Lugol's or Schiller's iodine. The epithelium is cervical in type and secretes mucus. The patient's complaint, if any, is leucorrhoea. Clinically, the condition can be mistaken for intractable vaginitis; histologically it has to be distinguished from adenocarcinoma (*see* page 462).

Vaginal adenosis results from faulty differentiation or distribution of müllerian duct tissue during the development of the vagina, one of the causes of this being exposure of the young foetus *in utero* to oestrogens. If the foetal vagina is exposed to *large* amounts of a non-steroidal oestrogen, as used to happen when recurrent abortion was treated by giving the mother massive doses of diethylstilboestrol (DES), it can be permanently affected. The consequence is the finding of vaginal adenosis when the child grows to adolescence or early maturity. This is sometimes associated with minor degrees of vaginal stricture formation, just below the level of the cervix. The chance of this happening is calculated to be very small statistically but it is serious because the adenosis may be associated with, or be the forerunner of, a *clear cell adenocarcinoma*.

Vaginal adenosis can undergo spontaneous cure by metaplasia into squamous epithelium. Failing this, it always needs to be kept under observation and, if it causes symptoms, the appropriate treatment seems to be ablation of the lesions in the hope that squamous epithelium will grow over the raw areas. Progestogen therapy is also advised by some. For extensive and resistant lesions, excision of large areas of the vaginal wall, followed by skin grafting, is reported.

## CERVIX

### Ectopy ('Erosion')

#### Pathology

A *cervical ectopy* is a condition in which the squamous covering of the vaginal aspect of the cervix is replaced by columnar epithelium which is continuous with that lining the endocervix. It is not an area denuded of epithelium as the name implies. Small areas of ulceration sometimes seen microscopically are the results of secondary infection and local trauma, or are artefacts. An ectopy has a bright red appearance with a clearly defined edge, the colour being explained by the underlying vascular tissue showing through a thin epithelium. The columnar epithelium may be arranged in a regular pattern but is sometimes proliferated and heaped up to form villous projections - a *papillary ectopy*. Beneath the epithelium the tissues often show round cell infiltration and glandular proliferation (Fig. 25.9). Some assume that these signs are indicative of a chronic infection which precedes and causes the *ectopy* (see below). Any inflammatory process, however, is more likely to be secondary, the columnar epithelium having less power of resistance to infection than the normal stratified covering.

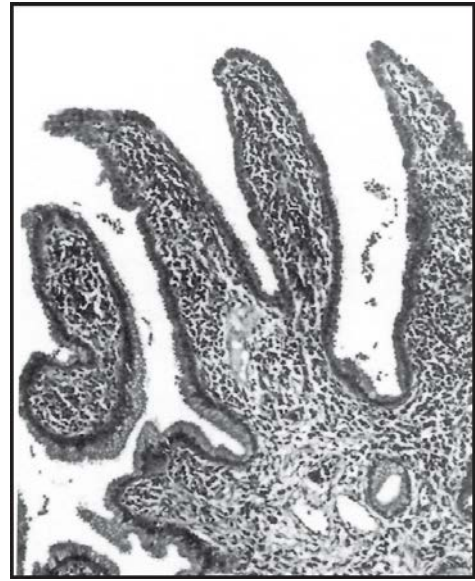
An ectopy is not a static condition and the line of demarcation between the two types of epithelium moves to and from the external os. The junctional zone is referred to as the 'transformation zone' of the squamocolumnar junction. When it is advancing towards the os the ectopy is said to be 'healing'. In this process the proliferating squamous epithelium can obstruct the ducts and produce Nabothian cysts; it may also extend down into the crypts to produce the condition of *epidermidisation of the crypts*. This phenomenon, however, is better explained by metaplasia of the reserve cells in the endocervix (see below).

An ectopy was formerly thought to predispose to cancer of the cervix but this view is no longer acceptable. The junctional zone is, however, the site from which cervical smears should be taken.

### Aetiology

#### Congenital and Developmental

The stratified epithelium on the surface of the cervix and the endocervical columnar epithelium may have separate



**Fig. 25.9:** Cervical ectopy. The squamocolumnar junction lies to the left. The surface of the exposed endocervical tissue is thrown into a series of villus-like structures which may be seen colposcopically. This is normal (Photomicrograph  $\times 120$ )

origins. Alternatively, and more likely, they represent different types of differentiation of the same parent (müllerian) tissue. The squamocolumnar junction ordinarily coincides with the external os, but may lie either within the cervical canal or outside the external os. In the latter case the result is a *congenital ectopy*. This is not a pathological state and is said to be found in at least one-third, some say *all*, female babies at birth, possibly because of exposure to maternal oestrogen *in utero*. The ectopy tends to disappear during childhood only to reappear at or soon after puberty in one-third of teenage girls. This, again, may be an oestrogen effect.

#### Hormonal

In the adult, as in the foetus and adolescent, a cervical ectopy is determined by the amounts of progesterone and oestrogen in circulation, the probable operative factor being oestrogen. So, even if not present previously, an ectopy commonly and normally develops during pregnancy and then tends to undergo squamous metaplasia during the subsequent 3-6 months. The finding of an ectopy a few weeks after delivery was formerly thought to be evidence of low-grade puerperal infection and to require treatment. It is now generally

recognised that it is a physiological reaction. This concept is confirmed by the fact that the taking of oestrogen-progestogen oral contraceptives often causes an ectopy or makes one more obvious (the so-called 'pill ectopy'). Indeed, these preparations sometimes result in gross proliferation of the columnar epithelium of the cervix, causing it to move away from the external os. The transformation zone in the reproductive phase of life is a dynamic area and changes in relation to endogenous and exogenous hormone levels.

All this explains why a cervical ectopy is rarely, if ever, seen in a postmenopausal woman.

### *Infection*

An ectopy of the cervix was once regarded as always being indicative of chronic cervicitis, and surprisingly there are still some who, in view of the evidence, hesitate to discard this concept. It was, and still is, postulated that the initial infection, operating directly or by altering the vaginal pH and bathing the cervix in discharge, destroys the squamous epithelium around the external os leaving a denuded or potentially denuded area. At the same time it stimulates overactivity of the endocervical epithelium which grows down and out to cover the raw area. This is pure theory and quite out of keeping with the known natural life history of cervical ectopy. Moreover, it is ruled out by the fact that whenever an area of the portio vaginalis is deliberately denuded, it is the squamous and not the columnar epithelium which grows in to cover it. Indeed, this is the basis of treating an ectopy by destroying the columnar epithelium with a cauterly, diathermy, cryotherapy or laser.

### **Symptoms**

*Nearly all ectopies are symptomless.* When symptoms are present the possibilities are as follows.

### *Discharge*

This is essentially an increase of the normal cervical secretion (*leucorrhoea*) brought about by over-growth, overactivity and exposure of cervical crypts. It becomes mucopurulent if infection gains entry through the columnar epithelium or if there is coincidental cervicitis. It may even be blood-stained for a few days premenstrually when the tissues are most congested.

### *Contact Bleeding*

The epithelial area is fragile and sometimes bleeds on coitus and during defaecation. This symptom, however, should always raise the question as to whether the ectopy is in fact a carcinoma.

### *Other Symptoms*

Infertility, backache, pelvic discomfort and all the symptoms mentioned under chronic cervicitis have been ascribed to ectopy — without any acceptable justification.

### **Physical Signs and Diagnosis**

An ectopy is easily recognised on inspection as a bright red area continuous with the endocervix and with a clearly defined outer edge. Hyperaemia resulting from acute cervicitis, on the other hand, fades gradually into the normal tissues. Surface infection which is part of vaginitis shows as multiple lesions lacking continuity with the endocervix. An ectopy is not tender unless complicated by infection. It often bleeds from multiple pinpoint areas when touched or rubbed with a swab. It feels soft and granular, and gives rise to a grating sensation when stroked with the tip of the finger. The impression is similar to that provoked by attempting to smooth velvet against its pile.

An ectopy has to be distinguished from carcinoma, tuberculosis, syphilitic and other ulcers of the cervix. Although a cervical smear may be helpful, the distinction may not be possible except by colposcopy or biopsy. A common happening, however, is confusion between ectopy and ectropion in which the lips of the cervix are curled back to expose the red endocervix. Such an exposure can also be produced as an artefact, merely by opening wide a bivalve vaginal speculum.

### *Treatment*

An ectopy which is symptomless does not ordinarily require treatment. The cauterisation of ectopies discovered on routine postnatal examination is unnecessary and harmful. When symptoms are present and infection and dysplasia are excluded or treated, an ectopy can be treated by electrocauterly, by cryotherapy using a special probe cooled with nitrogen or carbon dioxide, or by CO<sub>2</sub> laser vaporisation. The resulting raw area takes 6-8 weeks to become covered with squamous epithelium. As coitus should be avoided until healing

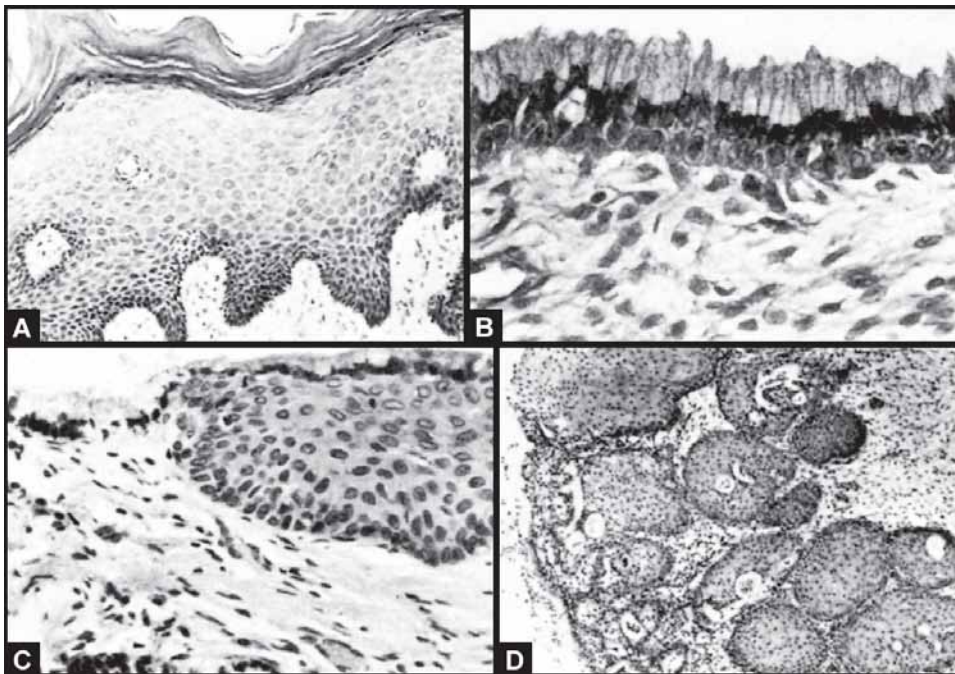
has taken place, this may be an opportunity to temporarily stop oral contraceptive therapy.

### Squamous Metaplasia

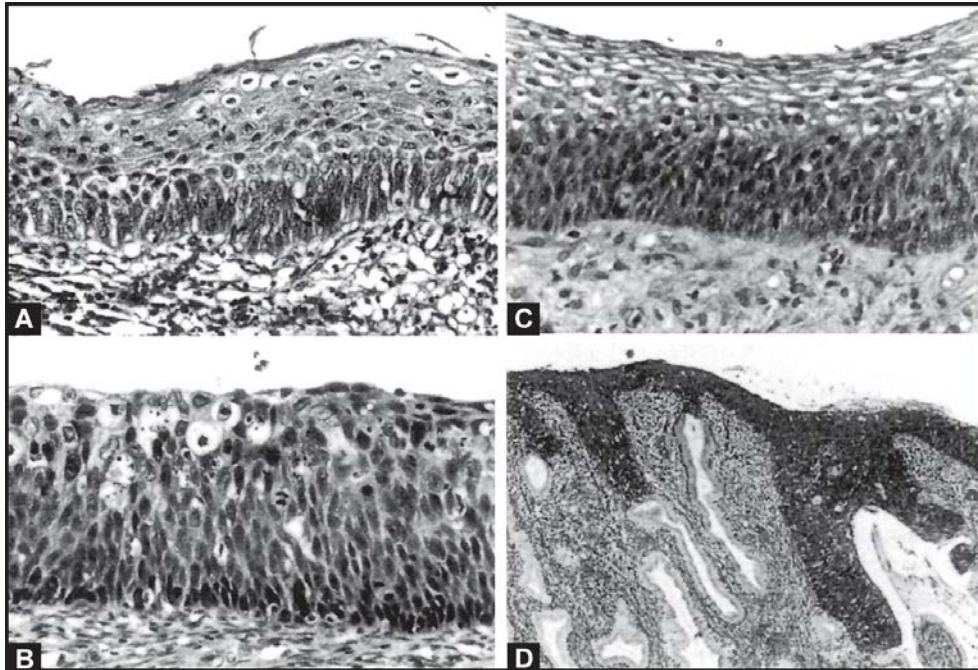
In theory, squamous epithelium may develop in the cervical canal as an error in the primary differentiation or distribution of müllerian and urogenital sinus tissues. When found in the adult, however, it is usually the result of *metaplasia*. Although in tissue cultures the columnar epithelial cells of the endocervix show a capacity to change to squamous cells, it seems likely that metaplasia stems mostly from a proliferation of the reserve cells which lie deep to the endocervical epithelium (Figs 25.10A to D). Initially, these become arranged as a plaque, several layers thick, beneath the surface columnar cells but the latter tend to break down in areas which then become lined by stratified squamous cells. At this stage the metaplasia is described as *incomplete*. In *complete* metaplasia, which is the same as *epidermidisation*, there are no columnar cells remaining in affected areas and the squamous epithelium also grows down into the

crypts whose columnar epithelium is replaced. In microscopic sections the resulting islands of squamous cells can be mistaken for malignant downgrowths of carcinoma (Figs 25.11A to D). In fact, the proliferation of reserve cells is always regular and devoid of excessive mitosis, nuclear changes and other features of malignancy. So metaplasia of any degree in the cervix is completely benign.

It is suggested, however, that during the process of metaplasia of columnar cells or of hyperplasia of reserve cells, the tissues are especially prone to virus infections and to take in foreign nucleic acids and that this may start mutations which lead to an increased risk of carcinoma of the cervix. Proliferation of the reserve cells is also postulated as a possible mechanism whereby the raw area of the cervix resulting from cauterisation of an ectopy becomes covered by squamous epithelium. The causes of metaplasia are unknown but one of the stimulating factors is probably the hormone environment of pregnancy; this would explain why it is sometimes found in newborn babies. Local irritants, infections and



**Figs 25.10A to D:** Benign epithelial changes in the cervix. (A) Reactive squamous cell hyperplasia. An orderly thickening of the epithelium with keratinisation. (B) Reserve cells. A single layer of orderly reserve cells lies beneath the columnar epithelium of the endocervix. (C) Metaplasia. A sheet of immature squamous epithelium, the result of reserve cell proliferation, lies under an intact columnar epithelium. (D) Complete metaplasia. Mature squamous epithelium replaces all the columnar epithelium but the outlines of the crypts remain. The picture should not be mistaken for downgrowths of cancer. (Photomicrographs presented by Dr Claud Taylor and reproduced by permission of the Editors of *J Obstet Gynaecol Br Commonw*, and of *J Clin Pathol*)



**Figs 25.11A to D:** (A) Cervix, CIN I. The basal third of the squamous epithelium is occupied by cells with high nucleocytoplasmic ratios, lacking stratification. Cytoplasmic maturation occurs in the upper two-thirds of the epithelium where there is cellular stratification but nuclear abnormalities persist throughout. (Photomicrograph x300) (B) Cervix, CIN II. The cells in the lower half of the epithelium lack stratification, have high nucleocytoplasmic ratios and show irregularities of nuclear chromatin distribution. Cytoplasmic maturation and stratification are seen only in the upper half of the epithelium. (Photomicrograph x300) (C) Cervix, CIN III. In this example, the full thickness of the epithelium is occupied by abnormal cells with high nucleocytoplasmic ratios, abnormal dispersion of nuclear chromatin and lacking cytoplasm: mitoses are seen in the middle and upper layers of the epithelium in contrast to their normal basal distribution. (Photomicrograph x300) (D) Cervix, CIN III. The surface of the cervix is covered by darkly stained epithelium with the features of CIN III. The atypical epithelium dips down to line several of the endocervical crypts. This appearance should not be mistaken for stromal invasion. (Photomicrograph x75)

factors such as alterations in the pH differential at the external os, are also suggested. Metaplasia is not uncommonly found in cervical polyps.

### Squamous Cell Hyperplasia

This is a benign and orderly hyperplasia of the squamous cell covering of the cervix. The whole epithelium can be thickened and microscopically some degree of hyperkeratosis, parakeratosis and lengthening of the rete ridges may be seen. The cells, however, do not show atypia. This change can result from local irritation, mechanical in the case of a prolapsed cervix, infective in the case of chronic *Trichomonas* or *Candida* vaginitis. The condition is therefore called *reactive hyperplasia* (Fig. 25.10).

In *basal cell hyperplasia*, the basal cells proliferate to form several layers instead of the usual one or two and

they look rather active, tending to have larger nuclei which are hyperchromatic. There is nothing to suggest disorderly behaviour in these cells and the middle and superficial zones of the squames show good stratification. Both reactive and basal cell hyperplasia are entirely benign and reversible states.

Another benign state of *reserve cell hyperplasia* is described; this can involve gland crypts and be mistaken for cancer. It is morphologically identical to early squamous metaplasia described above, but metaplasia is not an inevitable sequel.

### Cervical Intraepithelial Neoplasia: Dysplasia and Carcinoma *in situ*

A range of intraepithelial abnormalities of varying degree have been described in the cervical epithelium which are characterised by perversion of squamous cell

maturation and differentiation, pleomorphic and hyperchromatic nuclei and an abnormal number of chromosomes. Active mitosis may be apparent in microscopic sections.

The use of the term *dysplasia* for these led to its being regarded as a different pathological process from carcinoma *in situ*. It is now recognised that dysplasia and carcinoma *in situ* form a single and continuous process. The term cervical intraepithelial neoplasia (CIN) was introduced to emphasise the unity of those conditions formerly designated dysplasia or carcinoma *in situ*. CIN has been divided into three grades: CIN I corresponds to mild dysplasia; CIN II corresponds to moderate to severe dysplasia; and CIN III corresponds to severe dysplasia and carcinoma *in situ*. CIN is regarded as a single disease and begins at the squamocolumnar junction in the epithelium of the transformation zone. The interpretation of the histological appearances of the tissue is still subject to individual variation despite the more uniform criteria regarding CIN (Fig. 25.11). The natural history of CIN is difficult to predict because it is modified by diagnostic procedures and by treatment itself. Genuine regression to normal probably only occurs with CIN I because in this grade true CIN will be difficult to distinguish from inflammatory or infective changes. About one quarter of the cases of CIN I and II will progress to a more severe lesion without treatment and over a half of the untreated cases of CIN III will eventually develop invasive carcinoma. The aetiological

factors involved are the same as for carcinoma of the cervix, as discussed elsewhere.

#### Pathology

CIN is graded according to the proportion of epithelium occupied by undifferentiated cells. In CIN I (mild dysplasia) only the basal third or less of the epithelium is occupied by the undifferentiated cells. A lesion is classified as CIN II (moderate dysplasia) if the cells occupy between one-third and two-thirds of the epithelium. If more than two-thirds of the epithelial thickness is occupied by undifferentiated cells, a diagnosis of CIN III is made (severe dysplasia or carcinoma *in situ*). In the most severe form of CIN III, atypical cells occupy the full thickness of the epithelium and mitotic figures, often abnormal, are seen at all levels.

The main histological criteria of CIN III are: a disorderly and disorientated arrangement of closely packed cells throughout the *whole* thickness of the epidermis with loss of stratification. A few cells on the surface may be flattened but this does not imply stratification; an intact basement membrane with absence of rete ridges; variation in size and shape of cells; variation in size, shape and staining qualities of nuclei; usually but not always frequent mitoses (Figs 25.11, 25.12 and 25.13). The nuclei also invariably show a high percentage of abnormal chromosome patterns. The abnormal epithelium of CIN III often extends down into the endocervical crypts.

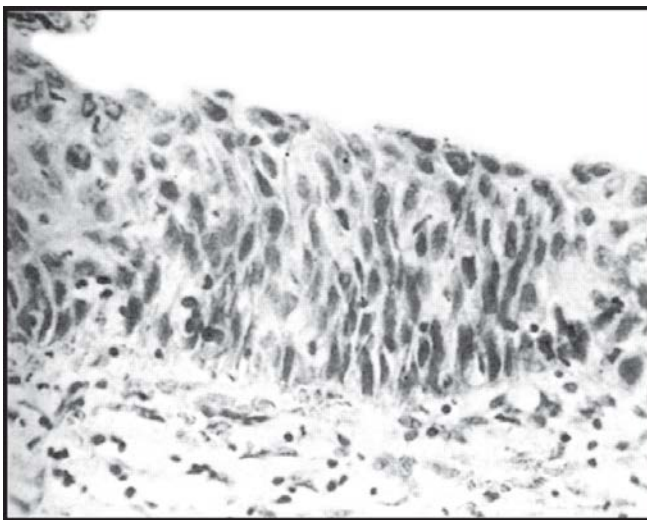


Fig. 25.12: Cervical intraepithelial neoplasia (CIN) to show the origin of cells seen in Fig. 25.13

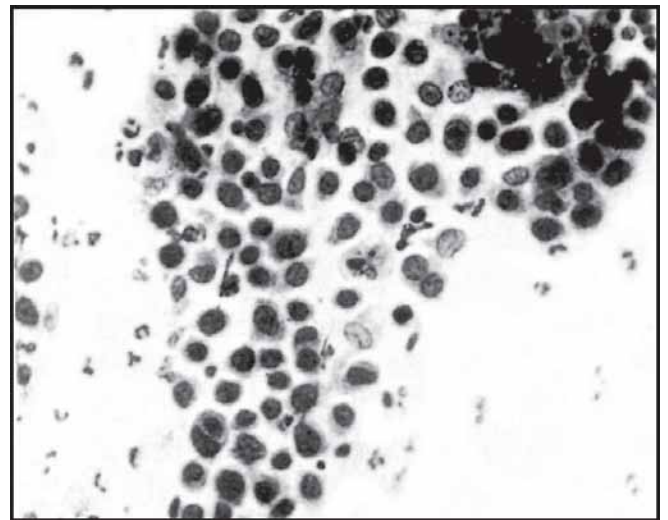


Fig. 25.13: Cervical smear of cells shed from CIN III shown in Fig. 25.12



Sometimes a few cells here and there break through the basement membrane and appear as tiny patches of growth with irregular spiky outlines which fray out to a minimal depth in the underlying stroma (Fig. 25.14). This condition is called *microinvasion* and is applied to a neoplasm which, although minimally invasive, is still predominantly intraepithelial. It has to be distinguished from *occult invasive carcinoma* which is any invasive lesion exceeding a microinvasive carcinoma in terms of confluence or depth of invasion without any clinical evidence of carcinoma but found histologically. Microinvasive carcinoma represents a stage in the progression that begins with intraepithelial neoplasia and ends with frankly invasive cancer. It is a lesion which is predominantly intraepithelial with a focus of invasion of less than 3 mm from the base of the epithelium, whether this is on the surface or within a crypt without any evidence of vascular invasion or confluence.

To establish the diagnosis properly requires a cone biopsy and serial sections.

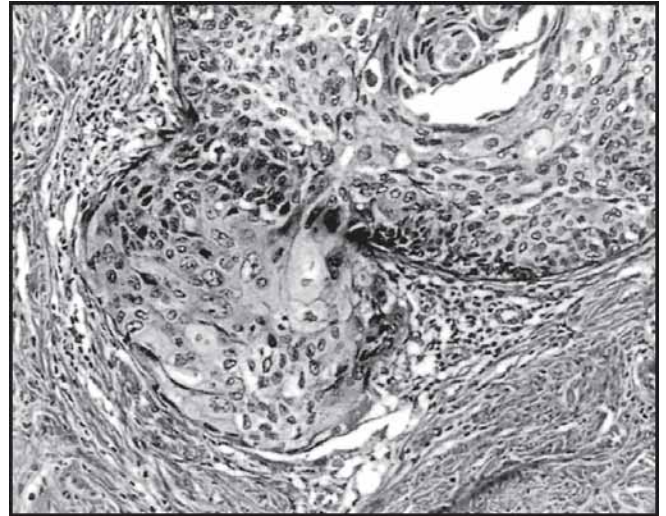
#### Frequency and Significance

Among women aged more than 25 years, CIN III is found in 0.2-0.4 per cent. This is a considerably higher incidence than might be expected if all such lesions progressed to invasive cancer. The discrepancy is explained by the fact that it becomes invasive in not more than 20-30 per cent of cases. Some put the figure lower, some higher, but observation in either direction can easily be prejudiced.

It takes 1-17 years for an *in situ* lesion to become invasive, with an average of 10 years. So the mean age at which carcinoma *in situ* is found is 35 years, the comparable figures for microinvasive carcinoma and invasive cancer being 44 and 53 years, respectively. Recently, in many developed countries there is a second peak of invasive carcinoma at between 30 and 40 years, and in these younger women the change from an *in situ* to an invasive lesion appears to be much faster (weeks or months rather than years). Coexisting HIV infection may accelerate the pace of the disease.

#### Diagnosis

Squamous metaplasia, squamous cell hyperplasia and CIN are symptomless conditions which may show no naked-eye signs of their presence. Indeed, the affected cervix usually looks remarkably healthy. The disease is therefore discovered either incidentally during the



**Fig. 25.14:** Cervix, microinvasive squamous carcinoma. To the upper right of the picture is an endocervical crypt lined by metaplastic squamous epithelium with the features of CIN II. A focus of invasive carcinoma breaches the basement membrane of the crypt at its left lower margin. Notice the inflammatory cell response to the invasion: it is predominantly lymphocytic. (Photomicrograph x185)

histological examination of cervixes removed for other reasons, or as a result of programmes for the routine screening by cervical cytology or colposcopy.

#### Cervical Cytology

The principles of cytodiagnosis and sampling techniques are discussed elsewhere. Table 25.2 compares the various systems of cytologic classification. Papanicolaou's initial description of 5 classes was replaced by the WHO system of grading of dysplasias and carcinoma *in situ*. Richart introduced the term cervical intraepithelial neoplasia to emphasise the continuum of changes. The Bethesda system of cytologic classification, while giving statements about specimen adequacy and general categorisation (normal, benign cellular change or epithelial cell abnormality), also gives descriptive diagnoses. Thus benign cellular changes may be due to infection or reactive changes. Epithelial cell abnormalities of squamous cells are classified as atypical squamous cells of undetermined significance (ASCUS), low-grade squamous intraepithelial lesion (LSIL), high-grade squamous intraepithelial lesion (HSIL) and squamous cell carcinoma.

Table 25.2: Classification systems for cervical cytology

WHO	CIN	Bethesda
Negative for cancer	Negative	Within normal limits
Atypical squamous cells	Negative	Infection (specify organism)
	Atypical cells	Reactive/reparative changes
	HPV atypia	Atypical squamous cells of undetermined significance (ASCUS) or
		Atypical glandular cells of undetermined significance (AGUS)
Mild dysplasia	CIN I	Low-grade squamous intraepithelial lesion (LSIL)
Moderate dysplasia	CIN II ]	High-grade squamous intraepithelial lesion (HSIL)
Severe dysplasia ]	CIN III ]	
Carcinoma <i>in situ</i> ]		
Invasive carcinoma	Invasive carcinoma	Invasive carcinoma

Similarly, glandular cells may be endometrial cells, cytologically benign, atypical glandular cells of undetermined significance (AGCUS) or adenocarcinoma. The Bethesda system has not been accepted universally.

Low-grade CIN is a term that includes flat condylo-ma, CIN I and LSILs. These are usually HPV-related. High-grade CIN is a diagnosis reserved for those cases truly considered pre-cancerous, i.e. CIN II and III. Aneuploidy is often seen in these lesions. Both low- and high-grade CINs may involve the glands but this is of no significance clinically and should not affect the management.

Low-grade CIN may revert to normal, persist, or progress to high-grade CIN. Patients with low-grade CIN are at risk of developing high-grade CIN, but it is not clear whether all high-grade CIN start as low-grade CIN, or whether some may arise *de novo*. However, high-grade CIN is undoubtedly a true cervical cancer precursor.

### The Results of Cervical Cytology

The accuracy of cytodiagnosis depends on the quality of the smear, the way in which it was obtained as well as on the skill and experience of the cytologist. As many as 10 per cent of smears prepared from cervical scrapings made by untrained doctors or nurses may have to be discarded. This figure falls to 0.3 per cent when a gynaecologist is responsible. An adequate smear is one which contains cells from the entire transformation zone and which, therefore, shows squamous metaplastic cells and endocervical cells. It should have adequate cell numbers, be properly fixed and not be obscured by blood or inflammatory exudate.

Using conventional techniques most of the cells are left behind on the sampling device (and this may include most abnormal cells). The smears are often not spread evenly. Liquid-based preparations are being developed to enhance the quality of the smear by transferring the entire sample onto the slide; the sampling implement is rinsed in a liquid preservative which is transported to the laboratory where a subsample, thin-layer preparation is made (Thin Prep). This is expected to improve accuracy and decrease the rate of false-negative results.

When the Ayre scrape technique is employed and by combining the findings on a repeat smear when the first is negative or doubtful, a false-negative rate of 1 per cent and a false-positive rate of up to 5 per cent is not unusual. Only in the hands of a very expert cytologist can these figures be reduced to 1 in 500 for each category of error.

These findings apply only to women who do *not* have clinically recognisable cancer of the cervix. In those who do, cervical smears, even when repeated, show a false-negative rate of 10 per cent. The reason is that, with established cancer, the actively growing cells are deeply situated; those which are exfoliated from the growth are often necrotic and obscured by inflammatory cells. This high false-negative rate in cases of cancer emphasises that cervical smears should only be taken by someone who is competent to judge the health of the cervix clinically, and that cyto-diagnosis is for the woman who is free from symptoms or signs of malignant disease. When such are present it is essential to proceed to colposcopy, cervical biopsy, curettage and other investigations, irrespective of the cytological findings.

In women aged 25 years and above in whom there are no clinical grounds for suspecting the presence of cervical carcinoma, cytodiagnosis leads to the recognition of carcinoma in 7 out of every 1000 cases. In 4 of these, the lesion is preinvasive, in 1 it is invasive. There are 2 or 3 additional cases in which CIN of varying degrees is found. The peak age incidence for positive smears is 30-40 years.

Cervical intraepithelial neoplasia is occasionally present during pregnancy but disappears spontaneously in the puerperium. At least 50 per cent of such lesions undergo reversal after pregnancy.

The figures given above apply to a general mixed population in towns and cities. Amongst groups of women known to be at special risk, those attending special (STD) clinics, or those belonging to lower socioeconomic groups living in adverse surroundings, for example, there are considerably more positive returns. Correspondingly, there are far fewer amongst women of the professional classes.

The standards of cytodiagnosis vary widely from one laboratory to another, even in the same country and amongst those where consistently high levels might be expected. In many the reporting is more unreliable than is the histological diagnosis of CIN III. The common error is to classify too many smears as malignant or 'suspicious'. Indeed, the standard of cytodiagnosis in any laboratory can be judged by the number of 'suspicious' returns. There should be none, and the only acceptable diagnoses are the categories listed in Table 25.2.

The variable standards are well illustrated by the fact that many laboratories dealing with material from similar populations report far more than 7 per 1000 slides as positive. This means a high false-positive rate and this is far more dangerous than a high false-negative rate. For it means that many women are exposed to unnecessary surgery and worry, the effects of which can be lifelong. Every year women are referred to me for treatment on the strength of an alleged positive smear, having been told they have cancer and that they require hysterectomy; yet on repeating the cytology no abnormal cells or cellular changes related to infection can be found in one smear after another and colposcopy reveals no major abnormality. Some of these are young married nulliparae complaining of infertility who have been advised to submit to hysterectomy. On occasion, it is a postmenopausal woman in whom the highly pyknotic nuclei of the parabasal cells are mistaken for malignancy.

A repeat smear after 6 weeks of hormone replacement therapy may prove normal. However, once a woman has been told she has a positive smear or that she has cancer, it is difficult to remove all fear and doubt from her mind.

Cervical cytodiagnosis as a routine measure is most valuable if it is done well; if it is not, it may do more harm than good. The best arrangement is for the pathologist to give an accurate description of any abnormal findings and then to discuss them and their implications *personally* with the patient's medical attendant. Between them they can decide whether further observation and repeat tests are necessary or whether colposcopy and cervical biopsy are called for. Typewritten impersonal communications from the laboratory to the clinician are the source of much misunderstanding and mishandling of the woman concerned.

#### *The Interpretation of Cervical Smears*

It has long been hoped that the workload of dealing with very large numbers of smears might be lightened by automating laboratory procedures. Automatic electronic scanners which react to the intensity of nuclear staining, and fluorescent microscopy of smears stained with acridine orange to show up large amounts of nucleic acids in the nuclei, have been tried. One-fourth of slides most likely to be negative are not reviewed manually, the remaining 75 per cent are reviewed by the cytotechnologist.

Technicians can be trained to pick out all the obviously normal smears and this means 90 per cent. The remaining 10 per cent require study by an expert cytologist, preferably a histopathologist, who needs to be aware of the normal cyclical variations in the character of vaginal, cervical and endometrial cells and the changes which they undergo with pregnancy. Local infections, especially those caused by *Trichomonas vaginalis*, also simulate epithelial activity which can be a trap for the inexperienced. The expert cytologist, however, has little difficulty in distinguishing inflammatory and hormone reactions from atypical or malignant activity.

#### *The Significance of a Positive Cervical Smear*

When cervical smears contain cells indicative of CIN II-III or malignancy, the next step is to carry out colposcopy since this will determine the site for a direct punch

biopsy; it can also help to decide whether to take action during pregnancy.

The symptom-free woman whose smear is positive during pregnancy with no apparent abnormality of the cervix should generally merely be kept under observation. If the smears remain positive and colposcopy does not exclude malignancy or a lesion suitable for laser therapy after she is delivered, she should then have a cone biopsy of the cervix.

The follow-up of a mildly abnormal smear is more debatable. The incidence of invasive cancer in this group of women is reported to be 208 per 100000 in the UK compared with an annual incidence of 9 per 100000. Smears reported as ASCUS (or AGCUS) should be followed with Pap smears repeated at intervals of 4-6 months till 3 consecutive smears are normal. Severe inflammation should be treated; postmenopausal women should receive oestrogen therapy. If a second report of ASCUS follows, or if the patient is a high-risk subject with previous abnormal Pap smears or the ASCUS is qualified as neoplastic by a cytologist, the patient should undergo colposcopy.

#### *The Value of Cytodiagnosis*

Cytodiagnosis undoubtedly permits the occasional discovery and early treatment of invasive cancer of the cervix in its initial stages. This often but not always results in its cure. The usual lesion found is CIN II or CIN III and these are not always forerunners to invasive cancer. The development of laser therapy has reduced many unnecessary operations but it is only suitable for CIN III lesions of the ectocervix. It also has to be remembered that after a cone biopsy or laser therapy for a CIN III lesion, the natural history of the disease is altered. Probably not more than 20-30 per cent of these cases would have become invasive.

It is almost certain that not all cervical cancers go through a pre-invasive stage, or this stage is so short that it is not diagnosed, so that cytodiagnosis does not always permit the disease to be diagnosed while it is curable.

In those areas where a large section of the female population has been regularly subjected to cervical cytology for several years, the incidence of cervical invasive carcinoma has fallen. Decreases of 30 per cent in 5-15 years have been reported from British Columbia and Ontario, for example. Yet it is not established that such a change is the result of routine cytodiagnosis which in turn leads to the elimination of CIN III. Similar falls

in the incidence of cervical cancer during the same period are reported from cities and areas where cytodiagnosis was not practiced. Indeed, it has to be recognised that, irrespective of the discovery and removal of pre-cancerous or preinvasive lesions, cancer of the cervix was becoming less common, especially amongst those communities where educational and living standards were being raised. On the other hand, modern methods of contraception and changing sexual habits and morals, are associated with a more virulent form of cervical cancer in women under 40 years of age. As a consequence, there have been only small reductions in incidence and number of deaths. Cervical cytology has also not had any impact on the prevention of adenocarcinoma of the cervix.

Despite its application to great advantage in the care of every patient seen during the last 30 years, the results and value of cervical cytology as at present applied to the mass screening of women still deserve critical study and appraisal.

#### *Colposcopy and Colpomicroscopy*

These techniques in which the cervix is visualised through optical instruments, are used to detect changes in the cellular pattern and vascularity of the covering epithelium. The magnification of the colposcope is 10-20 times and that of the colpo-microscope 100-300 times. So the latter offers microscopy *in vivo*. In assessing the grade of a lesion on colposcopy, the colposcopist looks at the surface contour, the arrangement of the surface capillaries, the distance between them and the presence of areas of leucoplakia. The evaluation of the transformation zone is of great importance as this is where the majority of cancers originate. If the transformation zone is not visualised, it is termed an unsatisfactory colposcopy and further evaluation is warranted. The endocervical canal can be evaluated with the help of an endocervical speculum and an endocervical curettage can be done.

The first step is to visualise the cervix under magnification. Any discharge present can be removed gently with saline. Leucoplakia must be looked for before applying acetic acid otherwise it cannot be differentiated from acetowhite epithelium (*see below*). Leucoplakia is a white area of thickened epithelium seen on the portio by the naked eye or by means of a colposcope. As in the case of the vulva, the white colouration, while denoting a deposit of keratin, is not indicative of any particular

type of epithelial behaviour underneath. Histologically, apart from patchy keratinisation, the underlying epithelium may be normal, show features of CIN or even invasive disease and should therefore be biopsied.

Condylomatous reactions caused by HPV may appear frond-like or can lead to leucoplakia. Biopsies should be taken especially when they arise from the transformation zone.

Frank invasive carcinoma can be identified before the application of acetic acid by the presence of the following: microexophytic epithelium - the surface is irregular, raised or ulcerated; atypical corkscrew or comma-shaped vessels of irregular calibre and branching pattern are seen. Viewing the lesion through a green filter allows clearer demonstration of the vasculature.

The second step in the colposcopic examination is to apply 5 per cent acetic acid gently but liberally.

In dysplastic epithelium, the nucleocytoplasmic ratio is increased and the increased nucleoproteins are precipitated by acetic acid about 30 seconds after application to make this area look opaque compared to normal epithelium, hence the term acetowhite epithelium. Terminal capillaries may surround circular or polygonal areas of acetowhite epithelium to give the appearance of a mosaic. Punctations may be seen within the acetowhite areas. These are the terminal ends of dilated capillaries.

Biopsies may be taken from suspicious areas under colposcopic guidance. Bleeding can be controlled with the application of Monsel's or silver nitrate solution or

by a pack. The application of Lugol's iodine used to be done routinely in the past - abnormal epithelium did not take up the stain as the dysfunctional dysplastic cells were devoid of glycogen. However, this is not mandatory if a thorough colposcopic examination has been done.

### Cone Biopsy

Using colposcopy it is possible to define which lesions are appropriate for laser therapy or cryotherapy. For those which are not totally visible, a cone biopsy is indicated because the abnormal area extends into the cervical canal, or there is a suggestion of invasion. A cone biopsy removes the whole of the squamo-columnar junction, but also a considerable part of the endocervix (Figs 25.15 and 25.16). The tissue so obtained is divided into 12-16 segments and each one blocked and sectioned separately. Only in this way is there reasonably good coverage of the cervix.

Following removal of the cone, the raw area should *not* be cauterised since this may destroy tissues which require study if hysterectomy subsequently becomes necessary. In my opinion, the raw area is best covered immediately with flaps of vaginal epithelium, paying careful attention to haemostasis. Many techniques are used, from leaving the area raw, to packing, to suturing the cervix laterally. The descending arteries on each lateral aspect of the cervix should be controlled by deeply placed sutures.



**Fig. 25.15:** A diagrammatic illustration of the common site of origin of a squamous cell carcinoma of the cervix and of the tissue removed in the course of cone biopsy



**Fig. 25.16:** Cervical cone biopsy demonstrated on a hysterectomy specimen. The single black suture, placed at 12 o'clock position before the incision is made, permits the histopathologist to orientate the specimen in the laboratory

Cone biopsy can result in immediate or secondary severe haemorrhage, especially when performed during pregnancy. Delayed complications include stenosis and cervical incompetence.

How reliable is the *histological* diagnosis of CIN of the cervix? Unfortunately, except in relatively few centres in the world, it is very unreliable in practice. A panel of pathologists appointed by the Royal College of Obstetricians and Gynaecologists examined material from more than 700 cases on which a firm diagnosis of CIN had already been made and acted upon in some of the best and most experienced units in Britain. The unprejudiced assessments of the members of the panel led to the conclusion that 30 per cent of the women concerned did not suffer from proven carcinoma *in situ*. Four per cent of these had cervixes free from any lesion whatsoever; 17 per cent had varying degrees of CIN, often slight; and the histological sections from the remaining 9 per cent were so unsatisfactory as to preclude any diagnosis. If this is what happens in relatively well-equipped and staffed hospitals, and there is evidence from other countries which confirms it, how many errors must be made taking the world as a whole? The toll in respect of unnecessary surgery and patient anxiety is inestimable.

### HPV Typing

HPV typing has also been used to identify low-risk patients. Types 6, 11, 41, 42 and 44 constitute a group with low or no oncogenic risk. Types 31, 33, 35, 39, 45, 51, 52, 56, 58, 59 and 68 have intermediate oncogenic risk and types 16 and 18 have high oncogenic risk. Addition of any of the three procedures described above helps to identify a subset of patients who should be treated.

### Treatment

Low-grade CIN patients can be kept under observation and monitored by Pap smear. However, 5-10 per cent of cases maybe underdiagnosed and 0.1 per cent of these may even have invasive or an endocervical cancer.

When opting for conservative measures, it is important to ensure patient follow up. Where this is doubtful, it is safer to treat all patients with abnormal Pap smears with a colposcopically identifiable lesion. Without an identifiable lesion, the patient is followed by Pap smear until a lesion is identified or until three negative smears are obtained.

High-grade CINs all require treatment. Treatment modalities vary depending on the age of the patient, nature of the CIN, desire for future fertility and facilities available.

### Curative Punch Biopsy

In young women with low-grade CIN and a small unifocal lesion located within the transformation zone (TZ), punch biopsy can be curative. To enhance the accuracy, it can be done under colposcopic guidance and the base curetted well. If the disease persists on follow up, other treatment can be undertaken.

### Cryotherapy

Cryotherapy uses nitrous oxide or carbon dioxide as a refrigerant to lower the temperature of the tissue below  $-22^{\circ}\text{C}$  for 3 minutes which results in cell death. Alternatively a freeze-thaw-freeze cycle is used. Cryodestruction occurs to a depth of 4-5 mm. Some lesions may extend deeper (up to 7 mm) and are the cause of treatment failure. Different sizes and shapes of probes are available (Fig. 25.17) and the one which is best suited to the lesion is used; flat probes are preferred. The aim is to produce an iceball that extends 5-10 mm beyond the margins of the lesion. This is confirmed by colposcopy. Multiple overlapping iceballs are required to treat large lesions adequately. The procedure can be done without anaesthesia. Only minor cramps are experienced, but postoperatively the patient often has profuse, watery discharge, which requires the use of a sanitary napkin. Electrolyte replacement is recommended. Light spotting may occur after two weeks when the char separates.

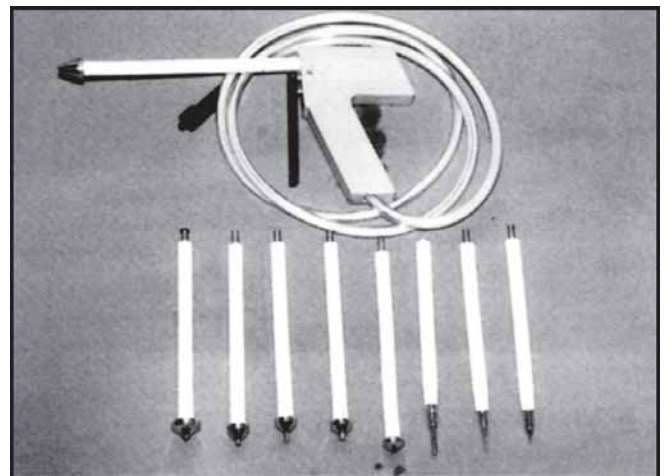


Fig. 25.17: Cryotherapy gun with probes of different sizes and shapes

Fertility is not impaired subsequent to the procedure but some patients may have cervical stenosis or cervical dystocia. In some patients the squamo-columnar junction may recede into the endocervical canal and subsequent evaluation may be difficult. This is especially likely if a probe with an endocervical extension is used. The success rate is about 93-97 per cent.

#### *Carbon Dioxide Laser*

This is a useful modality but is available at only very few centres in developing countries. It can be used both for ablation and for cutting, but in cervical lesions it is used to ablate those lesions confined to the portio. In all destructive techniques it is important to first rule out invasive disease by colposcopy-directed biopsy and endocervical curettage. The depth of destruction can be better controlled with laser.

Lesions extending into the endocervical canal can be subjected to laser conisation to rule out invasive disease.

Results of laser ablation are comparable with Cryotherapy, but vaginal discharge is less and the transformation zone is maintained. Cervical stenosis rates are the same. However, it is very expensive and special skills are required for performing conisation. Many centres now prefer LEEP (*see below*).

#### *Loop Electrosurgical Excision Procedure (Large Loop Excision of the Transformation Zone)*

Loop electrosurgical excision procedure (LEEP), also known as large loop excision of the transformation zone (LLETZ), has become the procedure of choice for the management of CIN in many countries.

LEEP can be learnt easily; it can be performed under colposcopic control, i.e. residual margins can be examined and residual lesions excised; it yields tissue for histopathological examination although the surgical margins may be charred. Histopathological evaluation is especially useful in cases of high-grade CIN; in such cases ablative procedures are not recommended. Different sizes of loops are available for LEEP and the appropriate loop is selected (Fig. 25.18). The use of a very large loop may result in amputation of the cervix with subsequent obstetric complications. The procedure is contraindicated in pregnancy.

#### *Cervical Conisation*

Traditional cold knife conisation is the time-honoured technique which continues to be used in most parts of the developing world to excise lesions that extend into the endocervical canal. Indeed, the cone biopsy essential for the diagnosis of the disease is usually curative. If the lesion is not suitable for laser therapy, this is often the appropriate treatment for younger women, and for older women as well.

Before accepting that cone excision of the tissues around the external os and the endocervix, or amputation of the cervix, is adequate for the treatment of any case, an assurance from the histopathologist that the line of incision is outside the diseased area is required. Moreover, regular follow up of the patient, with repeat cervical smears at 3-monthly intervals at first, is essential.

When the patient treated by cone biopsy subsequently conceives, one worry is whether the stimulus of pregnancy will light up the disease but this does not seem to occur. If the original cone has included the internal os, cervical incompetence resulting in abortion may ensue. Another possible complication is cervical dystocia during labour consequent upon scarring. In practice trouble rarely occurs.

#### *Total Hysterectomy*

If a smear remains or becomes positive after conservative surgery, total hysterectomy is indicated, but the ovaries need not be removed if the woman is premenopausal. There is also a place for total hysterectomy as an elective procedure when micro-invasion is found on biopsy, or when the patient is more than 40 years of age. Some gynaecologists advise hysterectomy in all cases. This may



Fig. 25.18: Two sizes of loops for LEEP

be justified if they are dealing with women likely to default from follow-up, but not otherwise. In fact, regular 'follow-up' cytology is as important after total hysterectomy as it is after conservative surgery. The woman who suffers from CIN III is the one most likely to develop similar lesions in the vagina.

A cuff of vagina should be removed only if there is clear evidence of disease in the vaginal vault. Most *in situ* lesions found in the vagina after hysterectomy represent new and separate developments, and not extensions from the cervical cancer. It is established that routine removal of a vaginal cuff does not improve the overall results.

Hysterectomy is *never* indicated merely on the finding of a positive cervical smear. Preliminary colposcopy and cervical biopsy is essential because cytodiagnosis is not completely reliable and does not permit a distinction between CIN III, microinvasive and invasive cancer; treatment of the last requires more than hysterectomy.

## UTERINE CORPUS

### Endometrial Hyperplasia

Endometrial hyperplasia is extremely common. It occurs at all ages, even in postmenopausal women.

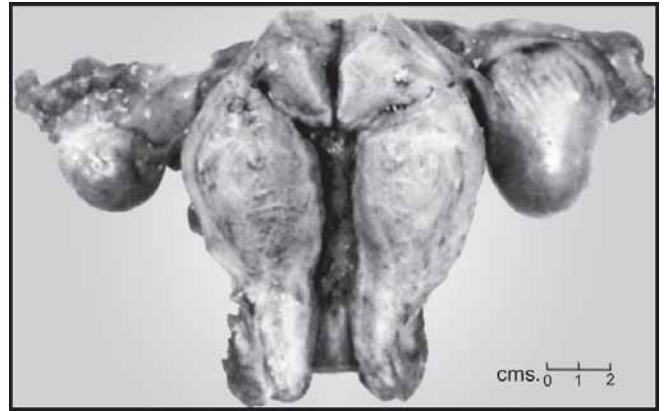
#### Pathology

The disease occurs in two main forms, simple and complex, but intermediate and mixed types are seen. Each of these may be associated with atypia.

#### Simple Hyperplasia (Cystic glandular hyperplasia)

In simple hyperplasia the endometrium often appears thickened to the naked eye: it may even be polypoidal (Fig. 25.19). On section the glands show hypertrophy rather than hyperplasia. They vary in size; some are small, some 'cystic' (Figs 25.20A to C). The cystic change is not usually due to blockage of the ducts but to extreme hypertrophy, so the cells preserve their columnar shape. The glands are always empty and the lining cells devoid of secretory activity and have no atypia. The stroma is hyperplastic and becomes unusually compact, so the glandular-stromal ratio is increased. Thus, the whole histological picture is one of an exaggerated proliferative phase.

Since the underlying cause is a prolonged oestrogen secretion unopposed by progesterone, the myometrium



**Fig. 25.19:** Generalised myohyperplasia of the uterus in a woman aged 52 years who suffered from recurrent episodes of irregular bleeding. The myometrium and the endometrium both show hypertrophy, the cause being an unopposed oestrogen secretion by the follicular cyst in the right ovary

simultaneously undergoes hypertrophy to cause diffuse uterine enlargement.

The combination of endometrial and myometrial hypertrophy constitutes *generalised myohyperplasia* (Fig. 25.19).

The threat of malignant change is small but all grades of endometrial abnormality between endometrial cystic hyperplasia and frank malignancy are sometimes seen in cases of carcinoma corporis (*see below*).

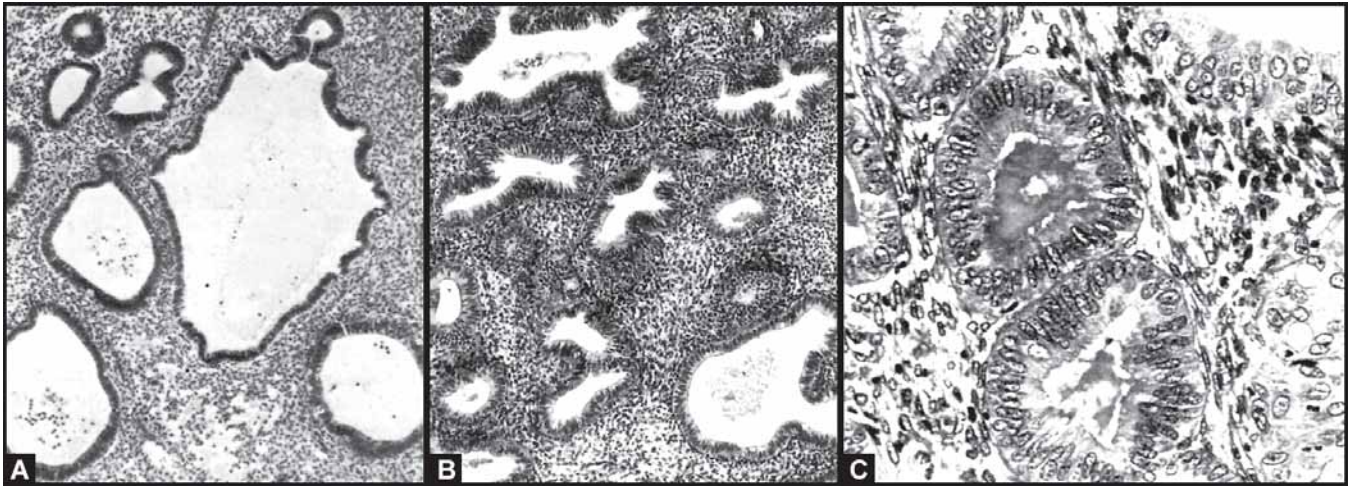
#### Complex Hyperplasia (Adenomatous hyperplasia)

Complex or adenomatous hyperplasia without atypia is sometimes found coexistent with simple hyperplasia, but ordinarily occurs separately. It is a state of true hyperplasia characterised by an increase in the number of glands. These may vary in size and become closely packed with little intervening stroma (Figs 25.20A to C). Cellular activity can be so great as to cause heaping and multilayering of the glandular epithelium with budding and infolding. The endometrium showing adenomatous hyperplasia rarely if ever exhibits secretory activity. This may reflect the cause of the disease but most probably indicates a fundamental abnormality in cellular function.

#### Atypical Hyperplasia

Both simple and complex hyperplasia can be associated with cytologic atypia. The nuclei are unusually large, pleomorphic, hyperchromatic with parachromatin





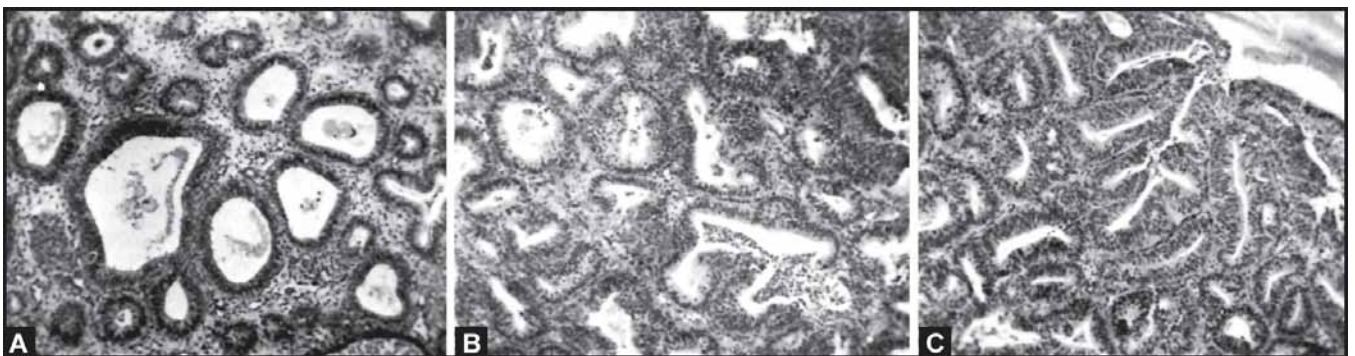
**Figs 25.20A to C:** Endometrial hyperplasia. (A) Simple hyperplasia (cystic glandular) characterised by enlarged non-secretory glands, with variations in size of glands and a compact stroma. (B) Endometrial glandular hyperplasia with architectural atypia. The glands are irregular in outline, with infoldings of their lining epithelium and out-pouchings. There is no cytological atypia in this example. (Photomicrograph x150) (C) Endometrial glandular hyperplasia with cytological atypia. The glands on the left are lined by epithelium of fairly normal appearance whilst that on the right is multilayered and shows loss of nuclear polarity and abnormalities of chromatin pattern. (Photomicrograph x370)

clumping, increased nuclear-cytoplasmic ratios and prominent nucleoli.

Usually the risk of hyperplasia progressing to carcinoma is related to the presence and severity of cytological atypia (Figs 25.21A to C). It is estimated that only 1 per cent of women with simple hyperplasia will progress to carcinoma over a decade whereas this risk is 8 times greater if there is atypical simple hyperplasia. Similarly, while complex hyperplasia is estimated to carry a 3 per cent risk of progression to malignancy, the risk increases to 29 per cent in cases of atypical complex hyperplasia. Certain risk factors are known to affect the

risk of progression: age, obesity, endocrinopathy, ovarian disease, endogenous hormone exposure (oestrogens, tamoxifen), etc. In 17-28 per cent of patients with atypical hyperplasia, an unexpected carcinoma might be found on hysterectomy, the risk of such an event being greater in postmenopausal women.

It has been proposed that the term 'endometrial intraepithelial neoplasia' be used to describe atypical hyperplasia. However, it is generally agreed that there is great difficulty in defining a true *in situ* lesion of the endometrium, i.e. a well-differentiated carcinoma confined to the endometrium, because complex atypical



**Figs 25.21A to C:** Aspects of atypical endometrial hyperplasia. (A) Minimal glandular architectural atypia. (B) Minor degree of glandular architectural atypia with a moderate degree of cytological atypia. (C) Severe architectural and cytological atypia

hyperplasia has a regression rate of over 50 per cent even in untreated cases, a feature not usually observed in neoplastic lesions.

### Aetiology

Simple hyperplasia occurs at all ages between puberty and the climacteric. It is caused by oestrogen acting in the absence of progesterone. Hormone assays show that sometimes, in simple hyperplasia, the oestrogen level is maintained for long periods of time at a moderate level. In other cases there are fluctuations between abnormally low and high levels. Simple hyperplasia results under any circumstances which determine a prolonged, increased or unopposed oestrogen production; these include follicular cysts, polycystic ovary syndrome (PCOS), granulosa and theca cell tumours of the ovary (Fig. 33.10). It can readily be induced by the administration of oestrogens of any kind.

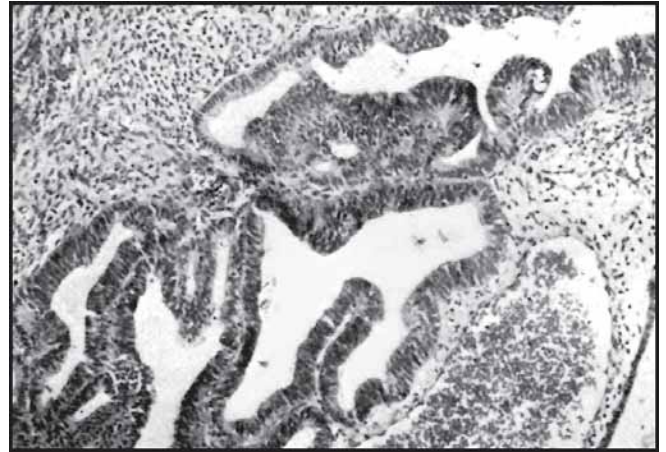
Complex hyperplasia is less obviously connected with an overriding oestrogen influence. Yet it can certainly result from oestrogen therapy and is sometimes seen in association with the abnormal ovarian hormone synthesis which is a feature of polycystic ovaries (Fig. 25.22). In many cases the cause is unknown.

Idiopathic complex hyperplasia can occur at all ages. It may occur in women as young as 20 years. Once present, it tends to persist for many years in some cases but is reversible.

Endometrial hyperplasia of either type occurring at the menopause is said to be associated with an increased incidence of derangement in glucose metabolism and hyperplasia of the stroma of the ovarian cortex.

### Clinical Features

Both forms of endometrial hyperplasia can exist without causing any complaint. Simple hyperplasia, however, especially if associated with fluctuating oestrogen levels, typically causes prolonged and heavy uterine bleeding with intervening short periods of amenorrhoea. Complex hyperplasia is also often discovered as a result of curettage for menorrhagia. Because of an underlying faulty ovarian function, or of the endometrial abnormality itself, infertility can be a symptom of both types. Neither gives rise to significant physical signs although the uterus may be palpably symmetrically enlarged. Hysteroscopy aids the localisation of an abnormal endometrium which is seen to be hyperplastic



**Fig. 25.22:** Endometrium with the features of architectural atypia and moderate cytological atypia. This endometrium was obtained from a woman aged 30 who presented with the polycystic ovary syndrome and had alternating phases of oligomenorrhoea and menorrhagia. The endometrial picture remained the same for 5 years after which time the uterus was removed because of the cancer threat. Sometimes the histological appearance regresses following progestogen therapy

and may have abnormal vascular patterns but the diagnosis of endometrial hyperplasia is essentially a histological one.

### Treatment

If an abnormal oestrogen influence is the background, the cause of this has to be removed. Functional ovarian upsets resulting in endometrial hyperplasia may undergo spontaneous cure. Meanwhile, a normal endometrial picture can be induced by cyclical hormone therapy. When the fault in the hormone stimulus is corrected, simple hyperplasia is reversible.

The treatment of adenomatous hyperplasia is more difficult. Treatment depends on the age of the patient, her desire for fertility and the presence or absence of associated atypia. Thus young women who desire fertility may receive ovulation induction. If pregnancy is not an immediate issue, cyclical progestogen therapy with medroxyprogesterone acetate or megestrol acetate 21 days a month for 3 months provides relief in over 80 per cent of patients. Such patients, however, need to be kept under supervision and have a repeat endometrial aspiration after 3 months. Treatment may need to be continued for 6 to 9 months.

Local progesterone administration by means of a levonorgestrel IUCD has also been successful. Combined use of gonadotrophin-releasing hormone analogues and high-dose progestogens has been found to be effective in research protocols. However, these are drugs with significant side-effects. If fertility is not a concern, endometrial resection is as effective with less side-effects. It is important to exclude atypia or malignancy. Endometrial ablation is not recommended as the tissue cannot be subjected to histopathological evaluation.

In the presence of atypia, response to progesterone therapy is poorer and the relapse rate is high. Nearly one-third of them will progress to cancer and one-fourth may already have associated undiagnosed cancer. Close vigilance with transvaginal ultrasound, endometrial aspiration or hysteroscopy-guided biopsy is required in this group if conservative therapy is chosen. The persistence of atypical epithelial activity may call for hysterectomy.

In women approaching or past the menopause, hysterectomy is a safer choice in those with complex or atypical hyperplasia.

### Squamous Cell Metaplasia of the Endometrium

#### Pathology

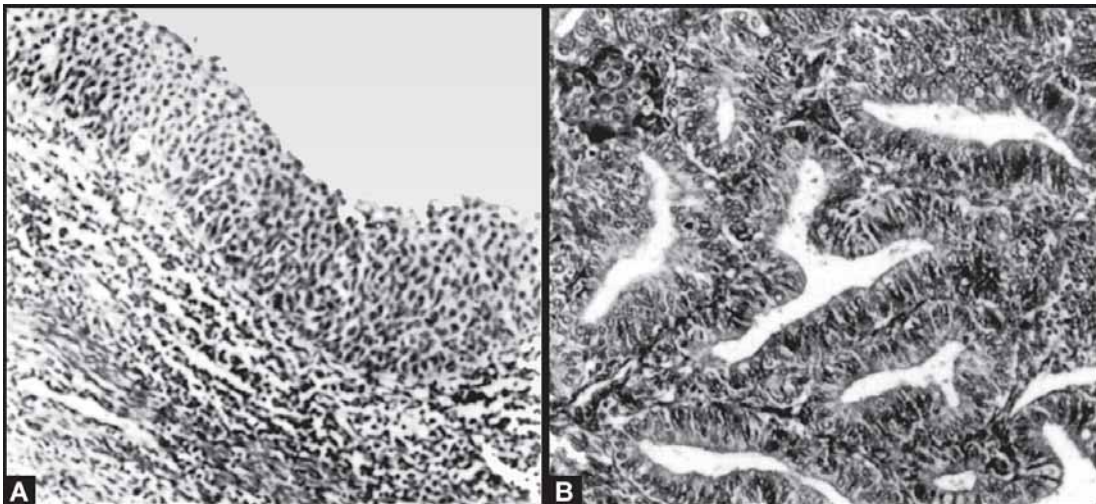
Squamous metaplasia of the columnar epithelium of the endometrium (*ichthyosis uteri*) is interesting but less

common. It affects mainly the surface (Figs 25.23A and B) but squamous cells can grow into and around the glands, or develop in them. Various degrees of cellular activity are present; sometimes squamous metaplasia is associated with adenomatous hyperplasia or endometrial polyps.

#### Aetiology

Squamous metaplasia is mostly seen in women aged more than 40 years, often they are postmenopausal. It is a possible response to pyometra, especially one caused by senile endometritis. In younger women it is described in association with tuberculous endo-metritis, and following prolonged exposure of the endometrium to mechanical or chemical irritants. Squamous cell metaplasia can be a response to any type of intrauterine contraceptive device. When it is, it usually disappears spontaneously; this can happen despite continued use of the device. Squamous cell metaplasia in these circumstances is to be regarded as a protective or reparative phenomenon. Squamous metaplasia also occurs in the absence of pyometra or other irritant, especially in older women, for reasons unknown, but a vitamin A or other deficiency state is postulated. Metaplasia is associated with adenomatous hyperplasia or endometrial polyps.

This condition is, by itself, symptomless and is usually discovered as a result of studying endometrium



**Figs 25.23A and B:** Squamous cell metaplasia of the endometrium. (A) This photomicrograph shows the surface columnar epithelium replaced by a many-layered squamoid epithelium. The uterus affected was the seat of a senile pyometra. (B) Endometrium with severe glandular architectural and cytological atypia. The glands which are of irregular, distorted form, are closely packed and lined by cells which are multilayered, rather pleomorphic and show some loss of polarity. (Photomicrograph x150)

removed for other reasons. It then has to be distinguished microscopically from the intrauterine surface spread of cancer of the cervix, and also from the accidental inclusion of cervical epithelium amongst curettings. The last is a common happening.

#### *Treatment*

Squamous metaplasia does carry a threat of cancer but generally there is very little risk. Senile endometritis, however, carries a definite risk. Because of this, and unless the patient is young, hysterectomy may be indicated.

#### **Other Forms of Endometrial Metaplasia**

Other tissues found in the uterus, possibly as a result of metaplasia induced by the same sort of factors as squamous cell metaplasia, include cartilage, bone and neuroglia. Their discovery, however, creates a need to exclude their being part of a mixed müllerian tumour or, even more likely, the aftermath of instrumental termination of pregnancy. In this operation, foetal tissues can be left in the uterus and maintain some sort of life, resulting in discharge or abnormal bleeding dating from the abortion.

#### **FALLOPIAN TUBE**

Epithelial abnormality of the endosalpinx is described as an incidental histological finding of little significance.

# CHAPTER 26

## Genital Cancers

The Importance of Genital Cancer	427
Treatment and Results	427
The Prevention of Pelvic Cancer	429
Early Diagnosis	429
General Management of the Cancer Patient	433
The Management of Advanced Pelvic Cancer	434

### THE IMPORTANCE OF GENITAL CANCER

The problem of cancer in general requires no emphasis. Although, for certain types of malignant disease, aetiological and precipitating factors are now established, the fundamental cause of neoplasia remains unknown; and the nature and results of its treatment are unsatisfactory. Moreover, as cures are found for other diseases, and as more individuals live to the 'cancer age', malignant disease is becoming relatively more important as a cause of death. In developed countries with good medical services serving communities such as those found in the UK, the USA and Australia, cancer now accounts for one out of every four deaths occurring amongst women and, of the cancer deaths, breast cancer is the foremost cause followed by lung cancer, both in greater proportions than all the genital cancers grouped together. The genital tract is the primary site of the growth in 14 per cent of cases. This figure is made up as follows:

*Uterus and cervix:* 8 per cent (approaching 1:1 in favour of endometrium)

*Ovary:* 5 per cent

*Vulva and vagina:* 1 per cent

Women who suffer from cancer of the breast are often unmarried, nulliparous and well-to-do; as a group they are opposite to those who develop malignant disease in the cervix.

The relative importance of different cancers is always shifting with changes in life expectancy, medical knowledge, and social circumstances and lifestyle. Thus malignant disease of the ovary, formerly regarded as not so important, now accounts for 50-55 per cent of the deaths due to genital cancers. In developing countries cancer of the uterine cervix is still the commonest, followed by ovarian cancer.

### TREATMENT AND RESULTS

The treatment of cancer falls mainly under the headings of surgery and radiotherapy or combinations of the two plus chemotherapy.

Both surgery and radiotherapy depend for their success on the complete destruction or removal of the primary growth. They aim to eradicate, or to arrest cancer cells which have reached the lymphatic field and, as techniques improve, attempts are made to remove or irradiate more and more lymph nodes and channels. Take, for example, carcinoma of the vulva for which, at one time, only the superficial inguinal nodes were removed, and with results almost as good as those obtained today. Gradually the dissection was extended until some began to advocate the removal or irradiation of even the para-aortic nodes. Is this rational? No matter how expert the surgeon and how brave and methodical his approach, it is impossible, except by a remote chance, to remove all the lymphatics draining a particular area. A macroscopic dissection of a microscopic lesion can never be satisfactory. This means that if cancer cells are ever demonstrated in lymph nodes, the patient who cannot cure herself is almost certainly destined to die from cancer sooner or later — no matter how extensive the operation. The same applies to ionising radiations, the effect of which on lymphatic fields is often limited and disappointing. This realisation has encouraged a return from this ultra radical approach.

Improvements in the development of chemotherapeutic agents with fewer side-effects may make drug treatment much more appropriate in the future. It is possible that immunotherapy may have a role to play in the future although, like chemotherapy, it will be most effective when the tumour volume is minimal. Proto-oncogenes and tumour suppression genes have been recognised. It is now known that the p53 gene is mutated in up to 50 per cent of solid tumours. BRCA 1 mutations are associated with an 80-90 per cent risk of breast cancer and a 50 per cent risk of ovarian cancer. Gene therapy is an exciting possibility for the future in prevention and treatment of cancers.

From these arguments, and they are amply borne out by observations on cancer of the cervix and of the vulva, it is difficult not to conclude that cancer which is not cured by local excision or by local destruction by radiotherapy is at present almost always incurable except by host resistance. Extensive block dissections and the exposure of large fields to radiation are either unnecessary (when the growth is localised) or ineffective in the long run.

This argument and consequent approach are being increasingly adopted in the treatment of cancers

elsewhere in the body. Thus most surgeons now favour simple, rather than radical, mastectomy, with or without irradiation, for carcinoma of the breast. Indeed, neoadjuvant chemotherapy can reduce the tumour size so that only a lumpectomy is required.

In concentrating merely on removing or destroying the parent lesion, it is important to have in mind that the natural defences of the body can often cope successfully with malignant cells which enter the bloodstream or lymph channels. That this is so is shown by the fact that even when growths are at an early stage, cancer cells can commonly be found in circulation and held up in small numbers in various tissues. Yet these must be destroyed because they do not give rise to metastases.

It is therefore essential not to impair natural resistance to cancer; and it is suggested by some authorities that removal of lymph nodes can do this.

The assessment of the results of treatment in terms of the length of survival of the patient raises the vital question - when is cancer cured? The very question is a condemnation of the present outlook, encouraged by statistics, which concerns itself with the disease and not the patient. The object of treating cancer is the elimination of every cancer cell; the object of treating the patient is to ensure physical and mental well-being for as long as possible. As things are, the woman with half her viscera removed, or with a rectal stricture or with urinary incontinence, knowing that she has had cancer and living in dread of its return; is regarded as cured. One who lives, albeit for a shorter time, in blissful ignorance of her fate and with her physical functions not too much impaired is regarded as a therapeutic failure.

No matter how they are assessed, the present results of treatment leave little room for complacency. Chemotherapy has made some headway, at least in the treatment of certain types of malignant disease. The cure for cancer, which will inevitably be found sooner or later, will presumably have a genetic or immunological basis - something which will attack the special metabolism of the cancer cell wherever it may be, leaving the normal metabolism of the healthy cell unimpaired.

More extensive operations and more powerful or precise machinery for emitting cancericidal radiation, with or without hyperbaric oxygen, offer little hope for significant progress. They are irrational when measured against the nature of the disease. Making those techniques of proven merit more widely available will

help to improve national or world statistics, but the main hope for the individual at present lies in the prevention of malignant disease or in its earlier diagnosis and treatment.

### THE PREVENTION OF PELVIC CANCER

As more is learned about the factors associated with malignant disease of the female genital tract, there is hope of preventing certain types. The elimination or control of what are believed to be causal agents, some viruses for example, could have an effect. The wider extension of better living conditions and higher standards of personal hygiene, male as well as female, and the avoidance of promiscuity and coitus at an early age, probably have much to offer so far as carcinoma of the cervix is concerned.

Vulvectomy for dysplasia of the vulvar epithelium has its place but does not always prevent squamous cell carcinoma in that site. Wholesale hysterectomy for all women showing cervical epithelial dysplasia, or suffering from postmenopausal bleeding or discharge, or whose family is complete, could well reduce the number of cancers of the cervix or corpus. Such an approach, however, is likely to involve operative mortality and morbidity rates which far outweigh the risk of the subsequent development of malignant disease.

Reason and safety impose strict limits on the place of prophylactic surgery in the prevention of cancer of the vulva, uterus, tubes and ovaries.

### EARLY DIAGNOSIS

It is generally accepted that an early cancer is more amenable to cure than one which has been present for some time. Therefore it is important to pay heed to the first suspicious symptoms or signs presented by the patient, for example, irregular uterine bleeding or discharge occurring after the age of 40 years.

Although early diagnosis and treatment must offer the patient a better chance of survival, they do not always make as much difference as might be expected. Stage I cases of cancer of the cervix can do badly while more advanced ones sometimes respond well to treatment. This is because certain growths invade the vascular channels at a very early stage, whereas others remain localised for months and years. Some women appear to have little inherent tissue resistance. Others can come to terms with their cancer - even to the extent of inactivating

malignant cells liberated into the blood or lodged in the bone marrow and elsewhere. The first type is rarely cured no matter how early the attack, the second is nearly always cured no matter how long treatment is deferred.

The results of therapy according to the stage of cancer of the cervix clearly show that the less the clinical extent of the disease, the better the outlook; but it is all too often assumed that the extent of a cancer represents its age. That this is not the case is shown by relating cures to duration of symptoms. It can then be shown that women who have symptoms for more than 6 months before being treated often show better 5-year survival rates than those with symptoms for only 3-6 months. This is because those women who delay taking advice either die before treatment is instituted, or they have a cancer which is only slowly progressive. This also explains why the clinical stage of cancer of the cervix is not necessarily proportional to the duration of symptoms.

Nevertheless, the earlier the patients report, the greater the relative number of Stage I growths and the better the overall 5-year survival rate. Even this argument, however, *may* be deceptive. Let it be supposed that a woman with a Stage I carcinoma of the cervix is treated in 1989 and dies in 1995; her survival for more than 5 years is then credited to early treatment. If the same woman neglects her symptoms and fails to take advice until 1994, the cancer has then progressed to Stage IV; she is treated but only survives until 1995 and thus contributes to the poor figures for Stage IV growths. In this case the day of her death is uninfluenced by early diagnosis and treatment. *This is hypothetical* but the fact remains that there is as yet no evidence to show even approximately how many more women would be saved by early treatment of invasive carcinoma of the cervix. Some of those whose lesion is only discovered microscopically following screening in 'well women clinics' and who receive prompt treatment, still die of the disease.

### Propaganda and Education of the Public

Women themselves are often slow to report symptoms; in developed countries the usual interval between the onset of symptoms and the taking of medical advice in cases of cancer of the cervix is:

- Less than 3 months: 25-50 per cent
- 3 months to 1 year: 20-45 per cent
- More than 1 year: 30 per cent.

For this reason, those who believe that early treatment will have a dramatic effect on the results often advocate propaganda to ensure that all women are aware of the early symptoms of cancer of the genital tract and breast. Unfortunately, some women are resistant to education by the mass media and are more likely to accept what they are told by friends than by doctors. Often it is the overanxious introspective woman who takes notice of such propaganda and she is forever producing symptoms which have no basis except fear. The woman with genuine symptoms often avoids taking advice because she does not wish to have her fears confirmed. She would rather remain in doubt because, whatever else she may have heard, she refuses to believe that cancer can be cured.

Despite the acknowledged risks of smoking, girls and young women are now amongst the heaviest smokers in the West. The lung cancer rate has more than tripled in women in the past three decades. To date, health education does not appear to have been heeded, although there has been some reduction in those who smoke during pregnancy.

That delay is not caused by ignorance is shown by the fact that women doctors and nurses wait just as long as do the laity before reporting suspicious symptoms.

In developing countries it is commonly observed, especially in the lower socioeconomic strata, that postmenopausal women are reluctant to report symptoms of bleeding and discharge to their families because of embarrassment, although they recognise their symptoms as being abnormal.

### Routine Medical Examination

One possible method of improving the results is to discover malignant disease before it has become invasive or, if already invasive, while it is still microscopic and asymptomatic. This means the routine screening of all apparently normal women who are at risk. Arrangements for this, however, usually concentrate on the detection of cervical cancer to the exclusion of other diseases which may be equally, if not more, injurious to health.

Since, in the West, cancer of the breast kills five times as many women as does cancer of the cervix, it can be argued that regular examination of the breasts is more important than routine tests on the cervix. Malignant conditions of the ovary, although less common, are mostly fatal unless detected in their early asymptomatic

stage. Again, diseases such as chronic hypertension, diabetes, and even obesity alone, may be potentially far more dangerous to a woman than is cervical intraepithelial neoplasia.

These observations mean that cancer detection clinics, or clinics devoted only to cervical or uterine cytodiagnosis, are of limited value. If the best results are to be obtained, cervical smears need to be taken merely as part of a full pelvic and general examination carried out by someone who is competent to recognize pelvic and other diseases by their clinical manifestations, and to give expert medical advice.

From the standpoint of detecting genital cancer in its early and preinvasive stage, cytology and colposcopy have proven their worth. CA-125 has been developed as a reasonably satisfactory tumour marker for ovarian cancer, which helps in the clinical management of certain cases, but it is neither a cost-effective method for widespread screening nor is it sufficiently specific. Similarly, transvaginal ultrasound and colour flow studies are useful but not suitable for large-scale screening (*see below*).

### Cytodiagnosis

Cytodiagnosis depends on the fact that surface cells are being shed continually from the epithelium lining the genital tract. They can therefore be collected and examined to see if they show histological evidence of unusual, if not malignant, activity. Basically cytology is not a method for diagnosing cancer; it is a means of screening apparently healthy and symptom-free women to discover those who deserve further investigation to see if they have malignant disease. Cancer can only be diagnosed with reasonable certainty by histological examination of tissue; such a diagnosis is an essential prerequisite for instituting cancer therapy.

### Techniques

#### *Vaginal Cytology*

The secretions lying in the upper vagina normally contain cells desquamated from the vaginal wall, the vaginal aspect of the cervix, the endocervix, the endometrium and sometimes the tubes. The examination of material in the vaginal pool, first suggested and used by Papanicolaou, may therefore be the earliest means of detecting misbehaviour in the epithelium in any of these sites but especially the cervix and the endometrium.

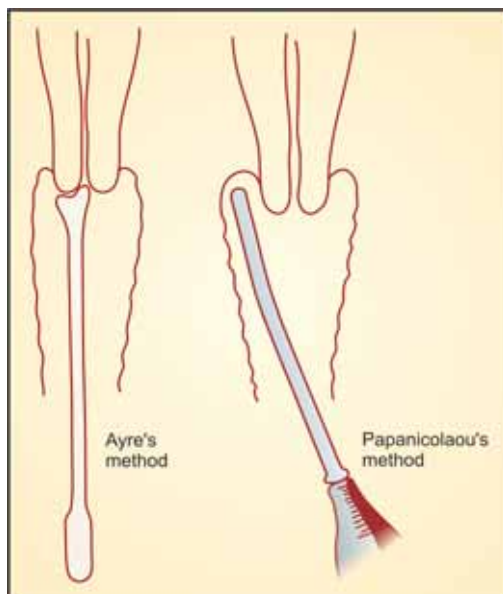


A specimen is collected from the posterior vaginal fornix in a pipette fitted with a rubber bulb to apply suction (Fig. 26.1). It is smeared on to a grease-free microscope slide and immediately (while still wet) fixed by spraying with 90 per cent alcohol to which a small amount of carbowax and glacial acetic acid is added. The slide dries in 5-10 minutes to leave the smear with a protective covering of wax and easy for transfer to the laboratory. There it is stained, usually by the Papanicolaou technique.

This method of collecting material has the advantage that it can be done blindly by anyone, even the woman herself. Since the smear contains endometrial as well as cervical cells, its examination may give a lead to cancer in either site. On the other hand, the admixture of cells means that the cytologist finds it more difficult and time-consuming to interpret. So, since it is the detection of cervical lesions which is the more important, the cervical scrape method for obtaining material is preferable.

### Cervical Scrape

This method is the current gold standard. It involves scraping of the superficial cells from the external os and lower endocervix by means of a special wooden spatula



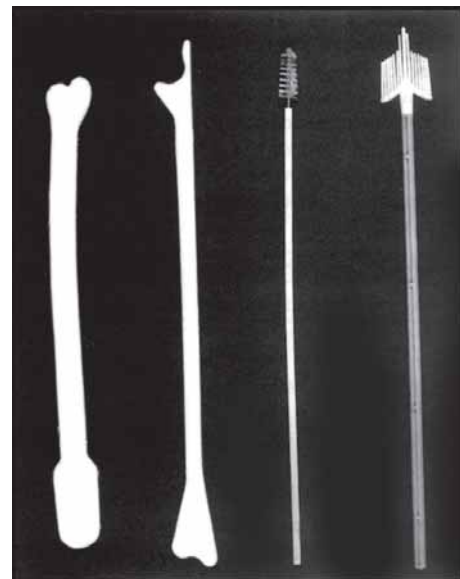
**Fig. 26.1:** The original methods for taking cervical and vaginal material to make 'smears' for the purpose of cytology. For Papanicolaou's technique, vaginal pool specimens are collected by some form of suction pipette

(Fig 26.2). Accurate application of the spatula to the *squamocolumnar epithelial junction* throughout its whole circumference is essential; this means direct vision of a well-exposed cervix. A smear is made from the material thus obtained and handled in the same way as described above.

The Ayre's 'scrape technique' is unreliable in picking up endometrial cells but is more efficient than the Papanicolaou method in collecting cervical cells. Moreover, the resulting smear can be assessed more easily and more quickly in the laboratory.

The Ayre's spatula occasionally yields an insufficient number of endocervical cells. The extended tip spatula with a longer endocervical limb has been found to have a higher rate of satisfactory smears. The Ayre's spatula can also be combined with the endocervical cytobrush to improve the yield of endocervical cells (Fig. 26.2).

This is the technique to be employed for the routine screening of apparently well women. It can be applied during pregnancy and is *not* ruled out if the woman is menstruating or bleeding for other cause. If the patient cannot return later, the blood or discharge can be gently wiped away from the external os and the specimen subsequently taken gives quite reliable findings in the hands of an expert in the field.



**Fig. 26.2:** Sampling devices for cervical cytology. From left to right: Ayre's wooden spatula, extended tip plastic spatula, endocervical cytobrush, Cervex brush

### *Intracervical and Intrauterine Aspiration Techniques*

These are not for routine screening purposes but for the investigation of women suspected on clinical grounds of harbouring malignant disease within the cavity of the uterus. The collection of endometrial cells on rotating brushes and other gadgets is now supplanted by endometrial lavage under negative pressure. Indeed, it is potentially dangerous to insert into the cavity of the uterus any instrument if there is a possibility of corporeal cancer or pyometra. Suction curettage by the Vabra aspirator is an effective method of obtaining endometrial tissue using a negative pressure. The endometrial biopsy curette used for the investigation of patients with infertility or the Karman-type cannula can also be used. Aseptic techniques are essential, but these can be applied without anaesthesia and without the need to admit the patient to hospital.

Suction aspiration of this type carries an accuracy rate of 90 per cent in the diagnosis of endometrial carcinoma and can sometimes reveal a growth missed by conventional diagnostic curettage.

### *Peritoneal Cytology*

The presence of ovarian cancer can be recognised or suspected by detecting malignant cells in centrifuged specimens of ascitic fluid. This old method, in use long before the introduction of vaginal and cervical cytology, may form the basis for neoadjuvant chemotherapy. However, even some patients with advanced ovarian cancer may not have positive peritoneal cytology. The same technique is extended to include the immediate examination of peritoneal washings obtained from the pouch of Douglas, paracolic gutters and subdiaphragmatic space during laparotomy in cases free from ascites. Collection of ascitic fluid from the pouch of Douglas or of peritoneal washings with heparinised saline for cytological analysis should be (but is not) a routine for all operations carried out for ovarian or endometrial carcinomas. Positive reports may influence the staging and management.

### **The Application of Cervical Cytology**

Ideally, cervical cytology should be carried out on all sexually active women, but this is impractical. If the first smear is reported free from abnormal cells, the test should be repeated within one year and preferably earlier. This is because a single negative finding, as with all laboratory procedures, carries a 10 per cent risk of

being wrong. The explanation is not only mistakes on the part of the cytologist, but also those made during the collection, labelling and handling of specimens at all stages of the test.

If a second smear is reported as being negative the chance of error is extremely small and the test need then be repeated only at 1-3-yearly intervals. Some say 5-yearly but this is too long. If a woman has had a series of negative smears by the age of 55, there is no necessity of further cervical smears as she is not likely to develop carcinoma of the cervix.

When the cytologist reports the presence of abnormal or suspicious cells, further evaluation should be carried out as discussed elsewhere. Even minor cytological variations are associated with major histological changes. Repeat smears for confirmation are therefore no longer recommended.

In practice, and no matter where facilities for cervical cytology are provided, only a proportion of women take advantage of them. These are mostly the women who are better educated, intelligent and belong to the higher socioeconomic group - the women who are least likely to develop carcinoma of the cervix. The same type of women attend postnatal clinics whereas those at greater risk tend to default. A programme designed to cover all or most women should therefore include routine cervical cytology as part of antenatal and postnatal supervision. Indeed, if all women attending for antenatal care, and all those seen in gynaecological, infertility, STD and family planning clinics were tested, many of those at risk would be included.

In developing countries, an extreme paucity of medical services, lack of access to these services and of trained cytotechnicians and laboratories means that the majority of women will never undergo a Pap smear. At the minimum, it is recommended that all women should have at least one cervical smear by the age of 40 years. Successful programmes for the clinical downstaging of cervical cancer have been developed: midwives and other paramedical staff are trained to do a speculum examination of the cervix and identify a suspicious cervix. All women thus identified then have a Pap smear. Thus limited resources are targeted at the high-risk population. The incidence of invasive cancer is reported to be 29 per 1000 in women with an abnormal cervix but only 1.53 per 1000 in those with a healthy cervix. However, this programme still awaits large-scale implementation.

## Colposcopy

Colposcopy is not a practical means for screening large numbers of asymptomatic women. It is too time consuming and, in any case, always needs to be supplemented with cervical cytology. It is useful for the further study of women whose cervical smears are reported as positive or doubtfully positive, and of those whose cervix is clinically suspicious despite negative cytological findings. Colposcopy then indicates the need and site for cervical biopsy and possible suitability for laser vaporisation therapy. The colposcope can also be used to visualise the vulva and vagina under magnification.

## Cervicography

Cervicography has been designed as a substitute for Colposcopy in those areas where medical services are available but not the services of a skilled colposcopist. In such a situation, two photographs of the cervix are taken with a specially designed camera, following the procedure of colposcopy. These are then sent to a specialised centre where they are developed as 35 mm slides, projected and reported by a specialist viewer. Further management is planned accordingly. More than 90 per cent of colposcopically diagnosed lesions can be correctly detected with cervicography. More importantly, cases of invasive cancer are accurately diagnosed. Thus this is a viable alternative to colposcopy for patients in remote areas.

## Ultrasound

Ultrasonic scans, especially by the transvaginal route, have been suggested as having a role in screening for ovarian cancer. The principal difficulty lies in recognising those at risk and, like breast carcinoma, a cancer will be present so the lesion will not be diagnosed before it is already invasive. Nevertheless it should be done annually in women with a family history of epithelial ovarian cancer or a history of prolonged therapy for the induction of ovulation. Addition of colour flow doppler studies and serum markers like CA-125 (*see below*) improves the sensitivity. However, these techniques are expensive, not widely available and are unsuited to large scale screening programmes.

Ultrasound has a major role to play in the diagnosis of trophoblastic disease and the differential diagnosis of pelvic and abdominal masses.

## Tumour Markers

Tumour markers are useful in the management of ovarian malignancy and gestational trophoblastic tumours, but have not been found useful as a screening test for the general population.

CA-125 is a tumour-associated antigen expressed by about 80 per cent of patients with epithelial ovarian cancer. It is not suitable for screening for ovarian cancer in the general population because it is elevated in many benign conditions with ascites and in non-gynaecologic malignancies where there is involvement of the pleura or peritoneum. When combined with clinical assessment and ultrasound, it may help to differentiate benign pelvic masses from malignant ones and is useful in the follow-up of malignancy and the detection of recurrence. Other tumour markers that have been used in ovarian malignancy are TAG 72 and CA 15-3.

Similarly alphafetoprotein (AFP) and  $\beta$ -hCG are useful markers for germ cell tumours of the ovary.

$\beta$ -hCG is a very sensitive marker for gestational trophoblastic tumours.

## GENERAL MANAGEMENT OF THE CANCER PATIENT

### Attention to General Health

No matter what the site and type of genital cancer, and whether surgery, radiotherapy or chemotherapy is contemplated, the patient's prospects are considerably improved if her nutritional state is at its best and if anaemia and cachexia are corrected before treatment.

### Should the Patient be Told the Diagnosis?

It has for generations been held that, with few exceptions, it is not in the interest of the patient to tell her that she suffers from cancer, and this view was reached by doctors who were more expert in the art of medicine than is the profession of today. Within recent years there has grown a body of opinion which takes the opposite view.

It is easy for both doctor and relatives to tell the truth and thus be spared much dissembling, trouble and even criticism when the patient is not making the progress she expects. It makes for personal comfort to shift responsibility, even at the expense of depriving the dying of all hope or of making the healthy live in fear of the recurrence which may never come. The conscience can

always be quietened with a glib assertion that it is unethical or immoral not to tell the patient the truth. Are those who take this standpoint equally candid about their errors in diagnosis or mishaps during operations? Do they tell a very sick man that he is suffering from pneumonia or heart failure? Or do they describe these conditions in the softer terms of congestion and weakness?

There are some who advocate telling the diagnosis to only those women who can be cured of their cancer. These patients, by advertising the good result, can then correct the public impression that cancer is incurable. But who can foretell which patient will be cured? Other doctors argue that they reveal the diagnosis to all patients in order to ensure a readiness to attend follow-up clinics. One tactic which can be employed from this standpoint is to describe the lesion in terms of inflammation which, if neglected, might possibly develop into a growth. This gives the excuse necessary to ensure continued observation and leaves the patient happy at the thought that she has avoided the dreaded disease. Prevarication or distortion of the truth is made all the easier by the fact that the woman herself is alert to accept any innocent explanation. This is true even for members of the medical or nursing professions. Even though they know or suspect the diagnosis, many wish to have it denied, not confirmed.

The reactions of patients vary, and undoubtedly change with a wider dispersal of medical knowledge. One follow-up enquiry amongst those who had been told of the presence of cancer showed that some were grateful to have the knowledge, some resented it, but many denied having received it. The last had deliberately closed their minds to the situation.

Unquestionably there are some people whose mental fibre is such that they are happier when their doubts are removed but these do *not* include the ones who with outward bravado say 'Tell me the truth, doctor, I can take it'. It is impossible to recognise those women who might be happier to know the diagnosis, even with considerable experience. It is preferable to keep the whole truth from the women unless a very radical operation is required. All patients who are going to have a colostomy (temporary or permanent) or urinary diversion, for example, and their immediate relatives, must be informed why such procedures are necessary.

The matter is clearly one on which there may be an honest difference of opinion, and on which procedure

must vary from patient to patient. It is essential always to explain the exact state of affairs to the nearest relative at the earliest possible moment.

### THE MANAGEMENT OF ADVANCED PELVIC CANCER

A problem commonly facing the medical attendant is the woman with advanced pelvic cancer - often a return of growth following ineffectual surgery or radiotherapy, with complications of treatment added. Such women are in a miserable plight which may last for months and years; their management and treatment are as much a challenge to the art as to the science of medicine.

#### Conservative Approach

This approach is to recognise that nothing more can be done to *cure* the patient, and to concentrate on relieving symptoms as they arise and on making the woman's remaining life and ultimate death as comfortable as possible. Death itself is not a dreadful thing; it is the manner of it which counts. In the terminal phases, nature usually takes a hand and invokes uraemia to induce oblivion during the last few hours or days. When this or any other happening betokens the end there should be no meddling with nature by renal dialysis, resuscitation, intensive care or other modern gadgetry.

#### General Care

Morale is best maintained if the patient does not realise the situation and if she is encouraged to lead as normal a life as possible for as long as possible. There is no reason for denying any reasonable wish. Once she becomes bedridden, the problems mount because constant attendance and expert nursing are required if bed sores are to be avoided. Despite this, and provided that help and conveniences are available, the woman is happier to remain at home. For anorexia and nausea, antiemetics, alcohol and small doses of prednisolone are helpful. Cachexia can be counteracted by parenteral nutrition. Abdominal distension and dyspnoea caused by fluid effusions can be relieved by 'tapping'. Hospice care is an alternative for the terminal cancer patient who requires intervention and cannot be treated at home. It allows comprehensive management by a skilled team of doctors and paramedical staff aided by specialised counsellors, psychiatrists, music therapists, religious priests, etc. in an atmosphere of peacefulness and

cleanliness to allow the terminal cancer patient an atmosphere of dignity and comfort.

### Relief of Pain

The pain, which is nearly always present in the later stages of pelvic cancer, is of two kinds; both are sometimes present in the same case.

#### *Visceral*

This is often a diffuse type of pelvic pain which may be described by the patient as a dull ache or 'bursting'. Sometimes it is colicky and intermittent. It arises most commonly in the bladder or rectum but its origin can be uterine (as in the case of pyometra), intestinal (as in obstruction), or renal and ureteric (when the lower ureter is obstructed).

#### *Somatic*

This pain is localised to certain nerves or groups of nerves and is shooting or throbbing; it tends to be worse at night. It originates mainly from the sacral plexus but can have an obturator nerve distribution. It may result from infiltration of soft tissues, bones or nerves by the tumour.

Treatment for cancer pain is usually done in a step-wise fashion. The primary management involves assessment (by history, examination and investigation) of the likely cause of pain. The first step is to administer mild analgesics such as paracetamol or aspirin. Non-steroidal anti-inflammatory drugs (NSAIDs) are particularly useful in case of bony metastases where pain is mediated through prosta-glandin release, but they are useful in other cases as well. Many cancer patients may be receiving other drugs as well, so drug interactions and side-effects must be kept in mind while prescribing palliative therapy.

Next, the addition of a tranquilliser or an anti-depressant decreases anxiety, potentiates the effects of analgesics and raises the threshold to pain. Along with the care and concern of loved ones as mentioned above, music therapy and religion also play an important role here.

With advanced cancers, this therapy may not suffice to provide adequate pain relief. A wide range of opioids is available for the third step of treatment. Milder ones like codeine or dextropropoxyphene are used initially. Morphine is a stronger opioid. It is now available in an oral as well as parenteral preparation. The oral route is

the simplest. If there are problems of gastrointestinal absorption, the subcutaneous route is sometimes required. The intramuscular and intravenous route are seldom used. The latter, especially, gives only short-lived benefit and may be hazardous. A proportion of patients may develop addiction to morphine but this is of little consequence. Care-givers are sometimes concerned that there may be no stronger analgesic available later when the disease (and the pain) worsens, and need adequate counselling and reassurance. Indeed, the dose of morphine does need careful initiation and titration for effective results. It is started at a dose of 5-10 mg orally every 4 hours and increased as required. The usual dose requirement is 30-60 mg 4-hourly but some patients need doses of 100 mg. Controlled-release tablets have the advantage of twice-daily administration. Some patients develop severe constipation which may increase their discomfort and symptomatic relief may be needed. Oxycodone is tolerated better than morphine by some patients, but pethidine can itself cause neurotoxicity when used in high doses for prolonged periods and is not recommended.

The last step is the relief of neuropathic pain. Regular small doses of corticosteroids can relieve nerve root pains, reduce tumour oedema and produce euphoria. Antidepressants, anticonvulsants and regional anaesthesia blocks with long-acting anaesthetics are useful in these cases.

The rule is to choose a small range of drugs and to become expert in their use, alone or in combination. It is important, too, to administer analgesics regularly, which may be less than 4-hourly, not just when there is another bout of pain. They should never be given 'as a favour' and there is much to be said for letting the patient help herself to them as much and as often as she wishes. For these reasons it is best to keep to oral medication for as long as possible.

Surgical measures may sometimes be called for, e.g. drainage of a pyometra or an abscess or the relief of ureteric obstruction (*see below*).

#### *Haemorrhage*

When haemorrhage occurs from incurable malignant ulcers in the vulva, vagina and uterus, drastic remedies may not be indicated. Death from haemorrhage is one of the more comfortable escapes from misery. Radiotherapy can control recurrent haemorrhage but

cannot be used if the patient has had previous radiotherapy. In that case painting of the ulcer with acetone, or coagulating its surface with diathermy, not only stops the bleeding but temporarily clears up the troublesome offensive discharge. Acetone is an old remedy, the value of which now tends to be overlooked. Another alternative sometimes used is packing, with the application of Monsel's solution. Arterial embolisation may be possible if the main bleeder is identified.

### *Swelling of the Leg*

Oedema of the legs can be counteracted by posture and elastic bandaging. Often, however, it is the result of deep phlebothrombosis; this, sometimes followed by embolism, is not uncommon in advanced pelvic cancer. Embolism may offer a quick release for the patient and, in these circumstances, anticoagulant therapy is generally not indicated.

### *Urinary Tract Symptoms*

Hydronephrosis leading to subsequent infection, pain and obstructive uropathy is often seen with advanced gynaecological cancers especially of the cervix. Some of these may be candidates for nephrostomy or insertion of a stent. Surgery has a place in those patients where the expectation of life is not short. Medical means to reduce oedema and improve patency include the administration of corticosteroids.

Advanced pelvic cancer often means a urinary fistula and for this it may be best to transplant the ureters into the colon. The disadvantages of this operation - the risks of pyelonephritis and of electrolyte imbalance - do not matter because the treatment is merely symptomatic for a woman with only a short time to live. Before operation it is important to exclude the presence, or the impending presence, of a rectovaginal fistula; in such cases the ureters can be transplanted into an ileal conduit.

If these operations are contraindicated by active growth or impending death, it becomes a matter of preventing excoriation of the skin of the vulva by applying a barrier cream or grease, and of controlling the dribbling by liberal applications of cotton wool. Female urinals, in the form of bags which fit the vulva, are nearly always unsatisfactory. The leak from a high fistula can sometimes be controlled by inserting a Foley catheter into the vagina, or by packing the vagina with a sponge whose lower part fits into a soft wide-bore rubber tube.

### *Incontinence of Faeces*

A vaginal faecal fistula is not usually so troublesome as a urinary one, provided that diarrhoea is avoided. The patient learns to empty the lower bowel regularly and to douche the vagina clear of faeces immediately afterwards. If the incontinence is distressing, and especially if it is accompanied by dyschezia, colostomy is indicated. But if the patient suffers from radiation enteritis the frequent fluid motions can make a colostomy intolerable.

## Chemotherapy

A large variety of drugs have been tried to combat malignant disease. Those which have established merit in the treatment of cancer of the female genitalia and which are in common use are mentioned below. They are given individually or in various combinations, as supplements to surgery or radiotherapy, as prophylactics against recurrence after surgery, and to control or modify advanced cancer. In the last circumstance, chemotherapy can prolong life, and sometimes give comfort.

Chemotherapeutic agents may be cell cycle-specific or non-specific; the drugs which are cycle-specific act on cells in a particular phase of the cell cycle only and other cells are spared, e.g. actinomycin D acts on the G1 phase, adriamycin and methotrexate on the S, etoposide on the G2 and the vinca alkaloids on the M phase. Cells in the G0 phase are not affected. Cycle non-specific drugs can kill cells in all phases of the cell cycle.

Many of the details of usage of some of the drugs already appear in other chapters under the heading of treatment of individual malignant states. What follows aims to summarise these and to give a broad picture.

## Cell Growth Cycle

To understand how chemotherapy works, one must first understand the cell growth cycle. Most of the cells in a tumour are in the resting or G0 phase. In response to certain factors, normally growth factors or steroids, cells are induced to enter the growth cycle which is divided into two growth phases (G1 and G2), a phase of synthesis (S) and a mitotic phase (M). The G1 phase varies from cell to cell, ranging from 8 to 100 hours and in this phase there is hectic activity resulting in the synthesis of various enzymes and proteins which will be needed in the next phase of synthesis.

In the S phase, DNA is synthesised and thus doubled. This phase lasts about 10 hours and is followed by the

G2 phase. This is a shorter phase, about 5 hours in duration, during which RNA and protein synthesis occurs which provides for the requirements of the two daughter cells. During the G2 phase, DNA replication errors are also corrected.

The last phase is the phase of mitosis which lasts about an hour and results in the generation of two daughter cells.

### Types of Drugs

All the following groups except hormones act by destroying actively dividing cells or preventing their propagation. They are classified on the basis of their biochemistry.

#### *Alkylating Agents*

These cross-link DNA strands and deprive the cell of substances essential to mitosis, respiration and glycolysis, such as nucleoproteins and enzymes. They include the nitrogen mustards, chlorambucil, cyclophosphamide, melphalan, ethyleneimines such as thiotepa, and the newer agents ifosfamide and treosulfan. All are used for any form of pelvic malignant disease but especially for those arising in the ovaries and also for the breast and various sarcomas. Whilst chlorambucil and cyclophosphamide can be given orally, they are best given intravenously.

Since they cause bone marrow suppression, careful monitoring of the white cells and platelets is required. Cyclophosphamide and ifosfamide cause alopecia and a severe chemical cystitis unless the uroprotector mesna (sodium 2-mercaptoethane sulphonate) is simultaneously administered.

#### *Alkylating-like Agents*

Cis-dichlorodiaminoplatinum (commonly known as cisplatin), carboplatin, and decarbazine (DTIC) are classified as alkylating-like agents. Their precise mode of action is uncertain but they do have an alkylating effect although they may have other modes of action too. They are used in the therapy of ovarian carcinoma, germ cell tumours and cervical cancer. DTIC has been used in the treatment of uterine and soft tissue sarcomas.

Cisplatin causes severe nephropathy, nausea, vomiting, dose-related peripheral neuropathy and anaemia. It also produces tinnitus and hearing loss.

Carboplatin has less neurotoxicity, ototoxicity and nephrotoxicity than cisplatin, but may have greater myelosuppression, especially thrombocytopenia.

#### *Antimetabolites*

These can be divided into three groups: (1) folate antagonists, such as methotrexate, which are particularly valuable in the treatment of choriocarcinoma - they act by inhibiting the enzyme dihydrofolate reductase and by depriving dividing cells of coenzymes essential to the synthesis of nucleic acids. Methotrexate is generally a very safe drug. The commonest side-effect is mouth ulcers. However, in patients with renal compromise or ascites, it can be very toxic. (2) pyrimidine antagonists, such as 5-fluorouracil (5-FU) - it blocks thymidine synthesis and the incorporation of uracil into DNA. Myelosuppression and mucositis are the commonest side-effects. They are rarely employed systemically, but are sometimes applied locally in the treatment of vulvar intraepithelial neoplasia (VIN III); (3) purine antagonists, which have no established role in gynaecological cancer. Antimetabolites are often used in combination when they exert a complementary effect because of their cycle-specific behaviour.

#### *Antitumour Antibiotics*

Of these, actinomycin D and doxorubicin (adriamycin) are used for the treatment of malignant disease of the female genitalia, mostly trophoblastic tumours, ovarian cancer and sarcomas in the pelvis. Bleomycin has been used in cases of carcinoma of the cervix and of the vulva, as well as in testicular and bladder cancer. It has a pulmonary toxicity and careful monitoring is required to avoid severe complications. Mitomycin C has been used to treat tumours of the breast, cervix and ovary. They form irreversible complexes with DNA and interfere with its replication.

Doxorubicin causes myelosuppression and marked alopecia. More importantly, it is very irritant if injected subcutaneously inadvertently and it should be given in a rapidly running drip. The total dose is limited to 450 mg/m<sup>2</sup>; cardiomyopathy can result from higher doses. Epirubicin and mitozantrone are newer drugs in this group which are less cardiotoxic.

Bleomycin causes a dose-related pulmonary fibrosis, usually at doses greater than 300 mg/m<sup>2</sup>.

### *Plant Products*

Plant alkaloids such as vinblastine and vincristine have a specific "blocking effect on mitosis and are effective against sarcomas, ovarian germ cell tumours and cervical cancer. Derived from the common periwinkle plant (*Vinca rosea*), the vinca alkaloids bind intracellular microtubular proteins, destroy the mitotic spindle and arrest mitosis.

Peripheral and autonomic neuropathy are the main side-effects, especially with vincristine. Local irritation may be encountered at the injection site so they should be administered into a rapidly running drip. However, they are not myelotoxic.

More recently, paclitaxel has been extracted from the bark of the Pacific Yew tree. It also disrupts microtubule function and has been found to be extremely useful in the treatment of ovarian carcinoma and breast cancer. It causes myelosuppression, nausea, severe alopecia and hypersensitivity reactions. When combined with platinum agents it should be administered first and when combined with doxorubicin it should be administered last to promote synergistic action and decrease toxicity. Docetaxel is the first semisynthetic analogue of paclitaxel being used in clinical trials.

Epipodophyllotoxins are extracts from the mandrake plant. The active principle etoposide (VP-16) is useful in the treatment of gestational trophoblastic tumours. It does not inhibit the mitotic spindle, but acts by causing breaks in the DNA. It causes severe myelosuppression, nausea, vomiting and alopecia.

### *Other Agents*

Hexamethylmelamine is an oral drug used in protocols for ovarian and breast cancer; the mechanism of action is poorly understood.

### *Dangers*

All chemotherapeutic agents have real dangers and need to be carefully controlled. Cytotoxic drugs attack normal as well as neoplastic tissues, especially those which are always actively replacing themselves, namely the bone marrow, the intestinal mucosa and hair follicles. Hence anaemia and leucopenia are inevitable effects, and nausea, vomiting, wasting, stomatitis, conjunctivitis, ulceration of the mouth, gut and anus, skin rashes and alopecia are all common. The platelet level also falls and this can result in blood coagulation defects and haemorrhage.

Chemotherapy is controlled essentially by repeated examination of the blood. In general, maximum

myelosuppression usually occurs 10-14 days after treatment has been initiated. If the white cell count falls below 3000 per ml or the platelet count below 100000 per ml, treatment is suspended until the counts recover. Renal function has to be checked carefully when cisplatin and its analogues are used, and respiratory function must be monitored during bleomycin treatment.

During treatment the patient should be protected as far as possible by vitamin and iron supplements added to her diet, and by blood, red cell or platelet transfusions as and when required. Because her resistance to infection is lowered, routine antibiotic therapy may be indicated.

If given during the first trimester of pregnancy, cytotoxic and antimetabolic agents may kill or maim the foetus, especially the antimetabolites and alkylating agents. A higher abortion rate is reported. Chemotherapy in the second or third trimester is not reported to cause foetal abnormality but it may induce in the foetus side-effects experienced by the mother, e.g. leucopenia, thrombocytopenia, etc. Intrauterine growth restriction and prematurity have been observed but it is unclear whether this can be attributed to the chemotherapy or to other factors associated with the disease.

### *Treatment Regimens*

The objective of cancer chemotherapy is to provide the patient with the maximum therapeutic benefit with the minimal amount of morbidity. Since most drugs used are only relatively selective for tumour cells as compared to normal cells, most of the drugs have a narrow therapeutic range. Those involved in cancer chemotherapy have therefore to choose dosages within a narrow range because of the dose-response relationship and low therapeutic index of most drugs used. Short courses in full doses are generally preferred to long-term continuous small-dose therapy. However, determination of the most appropriate dose is a complex clinical skill, based on the anticipated response of the patient and characteristics of the drug(s) used compared with the morbidity of the treatment and the potential benefits. In a patient with advanced disease who will die, if untreated, in a short period of time, highly aggressive use of the drugs is justified if a significant potential for survival exists. If survival without treatment is expected to be prolonged, then caution is required in the use of drugs. Considerable clinical expertise is therefore necessary to make a decision regarding an individual patient's potential tolerance to chemotherapy and the proposed treatment.



All antineoplastic agents kill a constant fraction of cells, not a constant number, producing successive log falls in tumour burden with successive courses.

With the exception of gestational trophoblastic tumours, single-agent therapy rarely results in cure.

The use of cancer chemotherapeutic agents in clinical practice now relies heavily on combinations of drugs. As a consequence, combinations of two to five drugs may be used. The revised drug regimens have increased the efficacy and enhanced the anti-tumour capabilities of the presently available drugs. Further advances may be expected with continuing research in basic pharmacology, biochemistry and toxicology as well as into the intricate behaviour of the tumour cell.

The best results with chemotherapy have been seen with trophoblastic tumours and germ cell ovarian tumours. In other genital cancers, chemotherapy does not always cure a patient, so a proper balance of the advantages, potential or actual, and the disadvantages, namely the adverse effects, must be maintained by all those involved in treating patients.

### Hormone Therapy

Hormone receptor assays can be done on biopsies of hormone-responsive tumours, e.g. of the endometrium and therapy planned accordingly. Oestrogens are valueless in the treatment of genital cancer. Androgens merely have an anabolic effect. Progestogens, however, appear sometimes to arrest endometrial carcinoma and its metastases and are worth trying in the treatment of recurrent malignant disease of the uterus. The response is almost certainly related to whether the tumour contains progesterone receptors. The use of progestogens is described elsewhere. Anti-oestrogens such as tamoxifen may be used for oestrogen-dependent tumours but are more commonly used in carcinoma of the breast.

### Radical Surgery

Some take the view that it is wrong to accept what appears to be inevitable and that, if surgery is sufficiently radical, even the apparently hopeless case of pelvic cancer can sometimes be cured. The cure, however, is at the expense of injury to, or removal of, the ureters, bladder and rectum.

#### *Exenteration*

This operation is mainly carried out for central recurrence of cancer of the cervix after radiotherapy, but

sometimes as a primary treatment for advanced pelvic cancer of all kinds. It relieves pain, discharge, incontinence (but only by changing the site of incontinence) and can sometimes cure. Exenteration is technically possible when the growth is confined to the pelvis and is not fixed to the bony walls. Unfortunately, it is often not possible to judge the extent without laparotomy and this may mean only one exenteration operation for every three abdomens opened. The presence of oedema of the leg or of hip pain referred to the leg, are warnings against attempted exenteration. Poor renal function is also a contraindication. If pelvic nodes are involved, the 5-year survival rate is <5 per cent and the procedure should therefore be abandoned if any of the lymph nodes show evidence of metastatic disease.

The total operation consists of the excision of all the pelvic viscera, fascia and lymphatics, the woman being left with a separate colostomy and ileal loop bladder. In *anterior exenteration* the rectum is not removed and in *posterior exenteration* the bladder and ureters are spared and all other viscera removed. Because it is often impossible to conserve the rectum or bladder and ureters without leaving potential lymphatic spread, a total exenteration may be preferred for cure, which should be the aim of the operation. No exenteration operation should ever be carried out as a palliative procedure, except possibly in the presence of a vesicovaginal fistula.

These major operations, especially total exenteration, carry a high risk, even in the hands of those with special experience and facilities. For the total operation the average surgeon can expect a primary mortality rate of 3-10 per cent and a 5-year survival rate varying from 0 to 70 per cent, depending upon the extent of the disease, with an average of 25-35 per cent. Successful salvage is more likely in patients who have recurrence following primary surgery than in those following primary radiotherapy and whose tumour size is <3 cm. The patients most likely to benefit are those who have central pelvic recurrence at least 1 year, but preferably longer, after initial therapy.

Providing the selection is good then this ultra radical surgery is justifiable for a few women who have not only courage and fortitude but some special incentive to live longer. Recurrence may be expected in up to one-third of patients. Any woman for whom exenteration is contemplated should be aware of all its implications, and the medical attendant should beware of striving too hard to keep her alive. There is a difference between life and existence.

# CHAPTER 27

## Tumours of the Vulva

Swellings of the Vulva	440	Malignant Neoplasms	444
Varicose Veins	441	Tumours of Bartholin's Gland	450
Oedema	441	Urethral Tumours	451
Retention Cysts	441	Tumours of the Inguinal Canal	454
Benign Neoplasms	442		

### SWELLINGS OF THE VULVA

A complaint of *swelling* of the vulva may be caused by the following conditions.

- **Development abnormalities**
  - Hypertrophy of the clitoris
  - Phimosis or paraphimosis with oedema of the glans clitoris
  - Unilateral or bilateral hypertrophy of the labium minus
  - Accessory nipple or breast
- Injury
  - Haematoma
- Displacements
  - Vaginal or uterine prolapse, inversion of the uterus vaginal, cervical and uterine tumours projecting through the introitus
- Vascular changes
  - Oedema of the vulva
  - Varicose veins
  - Elephantiasis and false elephantiasis
- Infections
  - Acute vulvitis, infective or chemical
  - Furuncle and carbuncle
  - Condylomata acuminata (warts)
  - Syphilitic condylomas
  - Hypertrophic tuberculosis
  - Smegma concretions
- Retention cysts
  - Sebaceous cyst
  - Epidermoid cyst (inclusion dermoid)
  - Hymeneal and clitoral cysts (wolffian remains)
- Endometriotic deposits and cysts
- Benign neoplasms
  - Papilloma, fibromyoma, neuroma, neurofibroma, lipoma, angioma, lymphangioma, myoblastoma

- Hidradenoma (sweat gland tumour)
- Adenoma of wolffian duct origin
- Malignant neoplasms
  - Squamous cell carcinoma
  - Melanoma
  - Sarcoma
  - Metastases, blood-borne from any site, including choriocarcinoma and lymphoma
- Enlargement of Bartholin's gland
  - Bartholinitis; Bartholin abscess
  - Bartholin cyst
  - Adenoma
  - Adenocarcinoma
- Urethral conditions
  - Prolapse of the urethra, acute or chronic
  - Caruncle
  - Carcinoma
  - Cyst of Skene's tubules
  - Diverticulum of the urethra
- **Conditions of the inguinal canal and round ligament**
  - Inguinal hernia
  - Hydrocele of the canal of Nuck
  - Varicocele of the round ligament
  - Tumours of the round ligament including endometriosis

Many of the above conditions are considered elsewhere; this chapter is concerned only with those which are not.

### VARICOSE VEINS

Varicose veins commonly occur on the vulva during pregnancy (Figs 27.1 and 27.2), but disappear afterwards.

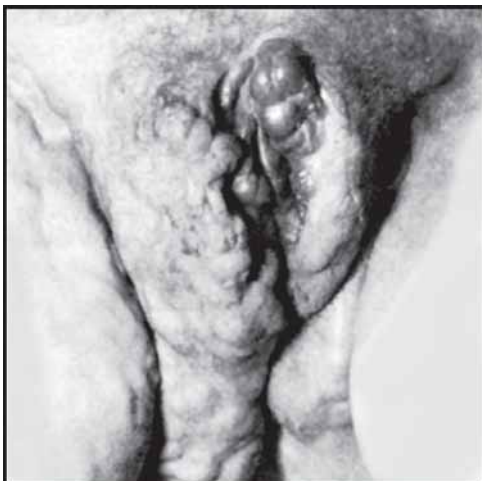


Fig. 27.1: Varicosities of the vulva during pregnancy

As a significant clinical entity they are rare in the non-pregnant woman, even one who has a badly affected leg. Symptom-producing varicosities in non-pregnant women are treated by the injection of sclerosing fluids or ligation of the long saphenous vein at a high level.

### OEDEMA

Oedema of the vulva has the same causes as bilateral oedema of the legs - heart failure, renal failure, large abdominal tumours, ascites, anaemia, malnutrition and the like. Its association with a pelvic or abdominal mass nearly always means that the tumour is malignant. Oedema of the vulva is common in pregnancy, especially as part of the syndrome of pre-eclampsia (Fig. 27.3).

The cure of vulvar oedema depends on removing its cause. Symptomatic relief is achieved by the patient resting in a bed, the foot of which is elevated. If this fails, multiple punctures of the skin with a sharp needle can have a dramatic effect (although performed rarely, this is still very effective).

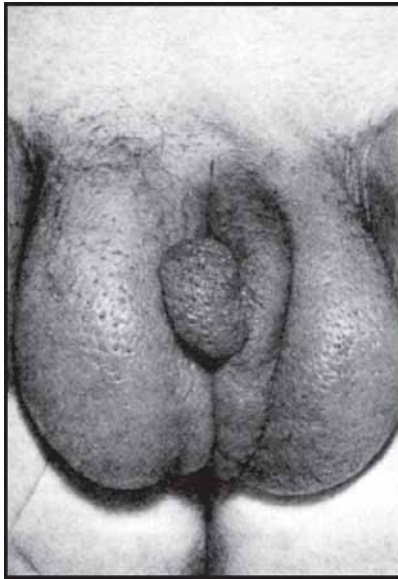
### RETENTION CYSTS

#### Sebaceous Cysts

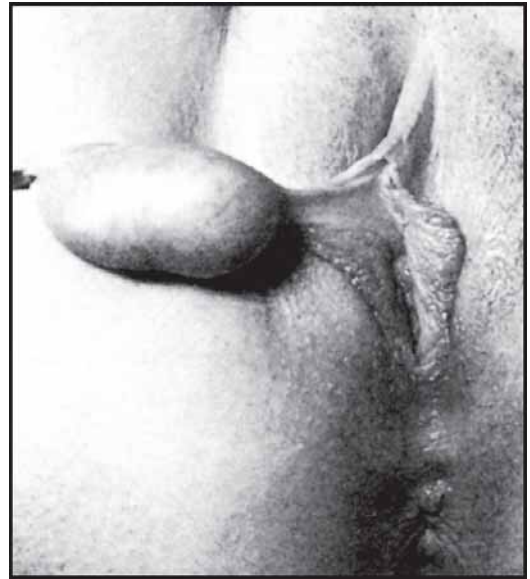
Sebaceous and apocrine glands are present in the labia majora and minora, and in the mons; cysts arise in them if their ducts are blocked by debris or fibrosis (Fig. 27.4). These rarely exceed a grape in size and, in the labia



Fig. 27.2: A severe degree of varicose veins of the legs (and vulva) associated with pregnancy



**Fig. 27.3:** Oedema of the vulva. The cause in this case was pre-eclampsia



**Fig. 27.4:** A sebaceous cyst of the labium minus. Treatment is by excision or incision, depending on whether the cyst is infected

minora, they tend to be tiny and multiple. Secondary infection is not uncommon.

### Epidermoid Cyst; Implantation Dermoid

Small cysts containing creamy yellow laminated keratinous debris material and lined by stratified epithelium are often found in the perineum and posterior vaginal wall, and sometimes in other parts of the vulva (*see* page 457). They are rarely bigger than a pea and are usually symptomless. Most of these cysts arise from small portions of perineal skin which become buried at the time of obstetrical injuries. Congenital inclusions are also a possible source; when they are, the cyst is always in the midline (Fig. 27.5).

Epidermoid cysts are easily excised if they cause symptoms.

### Hymeneal and Clitoral Cysts

These are thought to arise from remnants of the lower part of the wolffian (Gartner's) duct and are usually lined by cuboidal epithelium. The cysts mostly cause trouble by becoming infected and leading to recurrent abscesses or persistent sinuses.

### BENIGN NEOPLASMS

Benign growths may be composed of any of the tissues which make up the vulva. The commonest are the

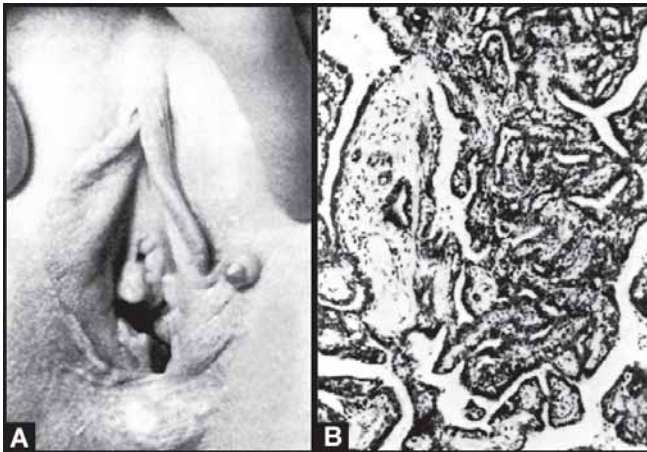


**Fig. 27.5:** An epidermoid cyst of the fourchette

*fibroma* and *lipoma* and these can reach large sizes. Others include the papilloma, pigmented mole, myoma, myoblastoma, haemangioma, lymphangioma, myxoma and neurofibroma. Adenomas are rare and are mostly small in size. They arise from sweat glands (*hidradenoma*) and from wolffian remains. Tumours of the latter are mostly found on the anterolateral aspect of the introitus,

near the urethra and clitoris. The hidradenoma is usually found on the foreparts of a labium majus. Typically, it forms a raised nodule, about the size of a pea, with a red and sometimes umbilicated top (Figs 27.6A and B). The last features are rather suggestive of a malignant ulcer but the tumour is quite benign.

Although sometimes sessile, vulvar tumours show a strong tendency to develop a stalk and to become polypoidal (Figs 27.7 and 27.8); their dependent parts then become congested, oedematous, and ultimately ulcerated.



**Figs 27.6A and B:** Hidradenoma (sweat gland tumour) of the vulva, (A) The position and size of the tumour are typical. The red-topped umbilication is a well-recognised feature but is not always present, (B) Microscopic section showing the benign adenomatous structure of the tumour



**Fig. 27.7:** A sessile leiomyoma in a woman aged 69 years. The surface ulceration at first suggested malignant disease but proved to be mechanical and ischaemic in origin

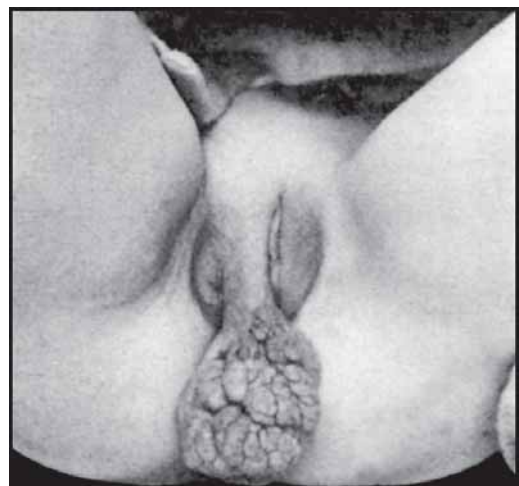
The patient usually complains only of the swelling, or of bleeding and discharge from it. Large tumours, however, can cause difficulty in coitus and labour.

The treatment of any tumour causing symptoms, or whose nature is in doubt, is by excision. Its structure is usually determined only by subsequent microscopic examination; such an examination is important if only to exclude malignant disease.

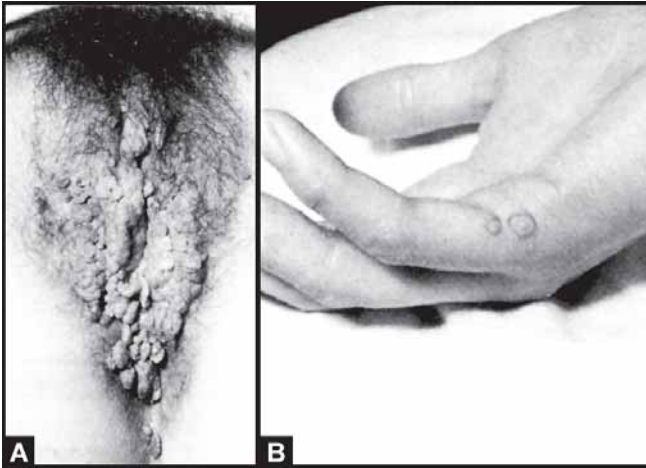
### Condylomata Acuminata (Vulvar warts)

Condylomata are papillary or verrucous lesions caused by human papillomavirus (HPV) infection. Types 6 and 11, the non-oncogenic types, are usually responsible for genital warts. On the vulva they are nearly always multiple. The virus can be transferred to this site from other parts of the body so warts elsewhere may be associated (Figs 27.9A and B). They can also be transmitted sexually and are highly contagious, affecting 75 per cent of sexual partners. Vaginal discharge provides an environment which causes them to flourish; and so does pregnancy. This environment of warmth and moisture, with little exposure to air, explains why vulvar Condylomata assume a form different from that of those found on the hands. Typically they are finely branched structures with a narrow stalk. They grow in clusters to give a cauliflower appearance; but they can be broad-based and coarse.

Condylomata acuminata are found on any part of the vulva and around the anus; but most commonly on the posterior fourchette and lateral areas; they spread within the introitus and sometimes involve the upper



**Fig. 27.8:** A pedunculated fibroma of the vulva



**Figs 27.9A and B:** Multiple warts (condylomata acuminata) of the vulva. These, like warts elsewhere, are caused by a virus but their particular character in this site is determined by warmth and moisture, (A) The vulvar lesions in a woman aged 24 years and pregnant, (B) This patient also had typical warts at the base of the fifth finger but vulvar warts commonly occur without lesions elsewhere

vagina and cervix. Their differential diagnosis is from syphilitic condylomata lata, squamous cell carcinoma, skin tags, molluscum contagiosum, sebaceous glands and lichen planus. Very rarely, condylomata of long standing can become malignant.

Therapy for genital warts aims to remove them. Eradication of the viral infection is not presently feasible. Several methods of therapy are available and selection of a specific regimen depends on the site, size and number of warts, the facilities at a particular centre, cost considerations and whether the patient is pregnant or not. Several treatment sessions are usually required to achieve a wart-free state.

Genital wart therapies may be patient-applied or provider-administered. In several countries, patient-applied treatments are available including podofilox solution and gel, and imiquimod cream. The provider-administered methods include topical, excisional or injectable treatments. Podophyllum resin has been commonly used for multiple condylomata which, when applied to them directly, causes them to shrivel and drop off within about 7 days. Various preparations are used but the common one is a 10-25 per cent emulsion in spirit or tincture benzoin compound. This has to be applied accurately to each wart with a cotton-tipped applicator taking care to avoid the surrounding skin. It is important

to wash it off in 1-4 hours. If the need arises, and it often does when the warts are many in number, treatment is repeated once or twice a week for up to 6 weeks. Each application is limited to 0.5 ml or an area of 10 cm<sup>2</sup>, to decrease the potential for systemic effects, e.g. bone marrow depression.

Podophyllin is cytotoxic and can be absorbed from the vulvar skin so its use is contraindicated in the first 3 months of pregnancy. It should also not be applied to warts within the vagina. These, like warts in any site — including the vulva — can disappear spontaneously. Condylomata which resist podophyllin therapy - and those which are coarse with thick stalks often do - are best snipped or shaved off under local anaesthesia and their bases cauterised. Trichloroacetic acid (TCA) 80-90 per cent solution has been used to treat small moist warts. Sodium bicarbonate can be used to remove the unreacted acid from the normal skin. Treatment is repeated weekly for up to 6 weeks. TCA can also be used to cauterise the bases of the warts after cutting. It is not as toxic as podophyllin and can safely be used in pregnancy. Tiny warts can be destroyed with the cautery, diathermy or cryotherapy. This sort of surgical approach is also appropriate for warts situated within the vagina. Laser has been used in patients who do not respond to other regimens. Thermal methods are more effective than therapy but electrosurgery is contraindicated for patients with cardiac pacemakers or with lesions proximal to the anal verge. Injections of 5-fluorouracil are rarely used because of their side-effects.

Recurrences are common with all modalities, occurring in at least one-third of patients. These are usually the result of reactivation of pre-existing subclinical infection. Sexual partners need treatment if they have manifest warts and should also be counselled regarding transmission risks.

## MALIGNANT NEOPLASMS

### Squamous Cell Carcinoma (Invasive)

Invasive cancer of the vulva accounts for only 4 per cent of cases of female genital cancer and most gynaecologists probably see less than 50 patients during their lifetime.

### Pathology

Cancer of the vulva can arise in normal skin, or within lesions of lichen sclerosus, squamous hyperplasia or vulvar intraepithelial neoplasia (VIN). The lesion

resembles skin cancer elsewhere, both macroscopically and microscopically. It usually appears as an ulcer with a sloughing base and raised edges, but fungating papillomatous forms and flat plaques are also seen (Figs 27.10 to 27.14). The disease affects any part of the vulva but the commonest sites are the labium majus and the clitoris. Multiple growths are not uncommon; sometimes

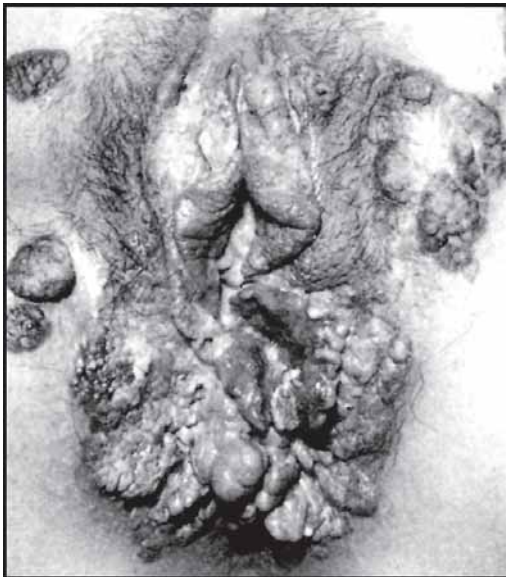
there are labial 'kiss ulcers' whose appearance suggests that the lesion spreads from one side to the other by direct contact - a disputed explanation. A wide-spread epithelial 'field change' in the skin of the vulva probably accounts for multiple primaries as well as a number of recurrences after treatment.



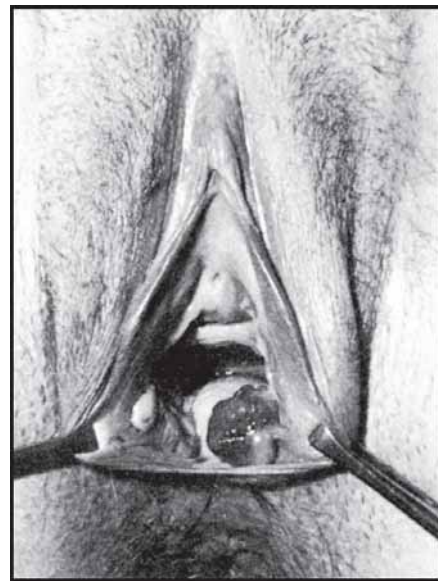
**Fig. 27.10:** Carcinoma of the clitoris. The white appearance of the surrounding skin is due to highlighting, not leucoplakia



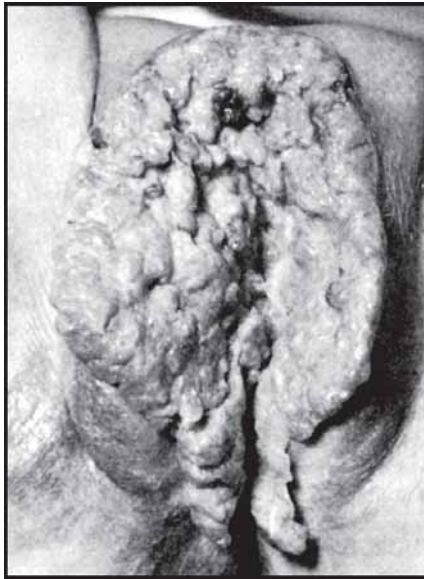
**Fig. 27.12:** An early ulcerative squamous cell carcinoma arising on skin which is affected by leucoderma, not leucoplakia. The skin is normal except for absence of pigment



**Fig. 27.11:** Multiple carcinomatous lesions of the vulva. Invasive, like *in situ*, cancer tends to be multifocal



**Fig. 27.13:** A relatively early exophytic and almost pedunculated squamous cell carcinoma arising just within the introitus; this is an unusual site



**Fig. 27.14:** An extensive proliferative cancer destroying all the tissues of the vulva. Involvement of the pubic bones prevented its complete excision

### Aetiology

Although recorded before the age of 20 years, vulvar cancer *is essentially a disease of old age*. It mostly arises between the ages of 50 and 80 years with an average of 62 years. The cause of the cancer is unknown but it is reasonable to suppose that any longstanding irritative agent - chemical, infective or mechanical, especially if combined with poor hygiene - can be an aetiological factor. Before they were adequately protected, women workers in cotton and woollen mills suffered repeated exposure to mineral oil and then proved more liable to develop cancer of the vulva.

Malignant change is also associated with chronic inflammatory diseases such as the venereal granulomas and vulvar warts of 20-30 years' standing, often with an intermediate phase of epithelial atypism. Where these conditions are common, as in the West Indies, vulvar cancer is said to be relatively more common and to occur in young women. Human papillomavirus is suspected to play a role in the aetiology of squamous cell carcinomas of the vulva.

Chronic vulvar epithelial disorders rarely lead to cancer unless they are accompanied by histological evidence of epithelial unrest and overactivity.

### Spread

Extension of the growth occurs by direct spread to the vagina, urethra, groin and anus. More important is dissemination by the lymph stream to the superficial inguinal nodes on *both* sides. From here the deep inguinal (femoral) and external iliac nodes become involved. Drainage to both groins occurs from midline structures, i.e. the clitoris and the perineum, but even other parts of the vulva may have some degree of contralateral spread. It has long been said that a cancer of the clitoris, even a small one, carries a bad prognosis because the rich blood and lymph networks in that site favour early dissemination directly to the deep femoral node of Cloquet, but modern observations do not confirm this.

Stages of carcinoma of the vulva are described but definitions of these vary and each surgeon tends to use his own. The latest one proposed by the International Federation of Gynaecology and Obstetrics (FIGO) for international acceptance is shown in Table 27.1.

This staging does not differentiate between heterogenous criteria, e.g. patients with negative nodes from those with positive nodes and therefore does not correlate with prognosis. The TNM staging clearly defines tumour size, node status and presence or absence of metastasis (Table 27.1).

The above staging is based on clinical observations, not operative findings. Of all cases of invasive cancer coming to operation, malignant cells are found in the superficial inguinal nodes in 30-40 per cent, and in the deep nodes in 10-15 per cent. The larger the area of the primary growth, the more likely is lymph node involvement.

### Clinical Features

The patient may suffer from pruritus or discomfort in the vulva, or be aware of a small tumour. Quite often she regards the lesion as a small septic spot or wart, which she neglects until ulceration causes some bleeding and discharge. The growth appears as an eroding ulcer with everted edges, or as a dirty discharging hypertrophic mass (Figs 27.10-27.14). It is hard and friable, bleeds easily and may be fixed to underlying tissues. These are the typical features, but atypical lesions of all kinds are seen and the only safe rule is to subject any persistent ulcer or nodule to histological scrutiny.

If the inguinal lymph nodes are enlarged, it is often impossible without microscopical examination to



Table 27.1: Staging of invasive cancer of the vulva

TNM	FIGO Stage		Description
Tis	0		Carcinoma <i>in situ</i>
T1 NO MO	I		Lesions 2 cm or less in size confined to the vulva or perineum. No nodal metastasis
T1 N1 MO			
		IA	Stromal invasion no greater than 1 mm +
		IB	Stromal invasion greater than 1 mm
T2 NO MO	II		Lesions greater than 2 cm, confined to the vulva or perineum. No nodal metastasis
T2 N1 MO			
T3 NO MO	III		Lesions of any size with (i) Extension to the lower vagina and/or urethra and/or anus and/or (ii) Unilateral regional lymph node metastasis
T3 N1 MO			
T3 N2 MO	IV		Tumour invades any of the following: (i) Upper urethra, bladder mucosa, rectal mucosa, (ii) Pelvic bone and/or (iii) Bilateral regional lymph node metastasis
T1 N2 MO			
T2 N2 MO			
Tx N3 MO		IVA	
T4 NO MO			
T4 N1 MO			Any distant metastases, including deep pelvic lymph nodes
T4 N2 MO			
Tx Nx M1		IVB	

T- Primary tumour: T1 - Tumour confined to vulva, maximum diameter 2 cm; T2 - Tumour confined to vulva, diameter >2 cm; T3 - Tumour of any size with adjacent spread as indicated above (Stage III); T4 - Tumour of any size infiltrating bladder, rectal or urethral mucosa and/or fixed to the bone.

N- Regional (inguinal-femoral) lymph nodes: No - No palpable lymph nodes; N1 - Unilateral palpable groin lymph nodes, not suspicious; N2 - Nodes palpable in one or both groins, enlarged, firm, mobile, clinically suspicious; N3 - Fixed or accelerated nodes

M- Distant metastasis: Mo - No clinical metastasis; M1 - Distant metastasis (including deep pelvic lymph nodes)

+ The depth of invasion is defined as the measurement from the epithelial-stromal junction of the most adjacent superficial dermal papilla to the deepest point of invasion.

determine whether the enlargement is a manifestation of secondary infection or invasion by tumour cells.

**Treatment**

*Prevention*

Chronic non-neoplastic epithelial disorders and other skin diseases of the vulva precede cancer in only a small percentage of cases. Nevertheless, the investigation, regular observation and treatment of these is the chief hope of preventing cancer at present. Those characterised by epithelial atypism may call for prophylactic vulvectomy but this is not an absolute safeguard.

*Surgical*

The standard treatment for established disease has been radical excision of the vulva with block dissection of the inguinal and femoral nodes on both sides, even in cases with unilateral lesions, because the lymphatics from one

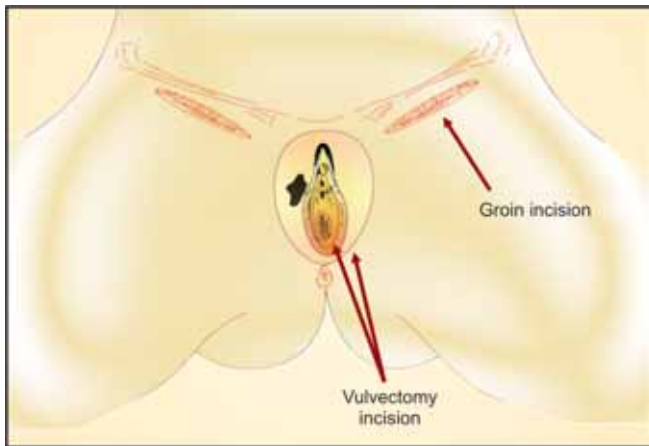
side are thought to communicate freely with the other. It is now recognised, however, that a flexible approach to the treatment of these patients may decrease the morbidity of the standard procedure while maintaining comparable survival rates.

In planning an operation it has to be remembered that squamous carcinoma of the vulva is generally a well-differentiated growth of relatively low-grade malignancy; and its owner is often an old woman, ill-fitted to withstand a radical procedure, and whose expectation of life is in any case limited. *Wide excision of the primary growth* sometimes means removing the lower part of the urethra, vagina or bowel, and leaving an area uncovered by skin which can take 2-3 months to heal unless skin grafts are used. When the wound is closed under tension there is a high breakdown rate. The most important modification of the standard *en bloc* excision has been the development of the three-incision technique in which the vulvectomy is the first and the bilateral groin incisions

are the other two incisions (Fig. 27.15). This method leaves a bridge of tissue between the incisions and spares the mons pubis. Groin wound breakdown is reduced by 50 per cent. This method may be considered in patients with early disease with clinically negative inguinofemoral nodes.

There is an increased risk of venous thromboembolism, and later of chronic oedema of the legs, following radical vulvectomy. Other problems include the possibility of urinary or faecal incontinence. The vulva may be left gaping or stenosed with a high incidence of psychosexual problems. But young women have conceived, and delivered normally, after this operation (Fig. 27.16).

Another important modification has been in the management of the regional nodes. Some surgeons used to advocate extending the dissection to include the external iliac and common iliac nodes in all cases, but such an extensive operation carries a high morbidity rate and it is now clear that the inguino-femoral nodes *must* be involved for the deep pelvic nodes to show metastasis. Thus pelvic lymph node dissection can be reserved for those patients with inguinofemoral metastases and, in some cases, be done only on the involved side. The second option is to give pelvic radiotherapy to patients with positive inguinofemoral nodes (*see below*). With this protocol, morbidity and mortality are certainly less.



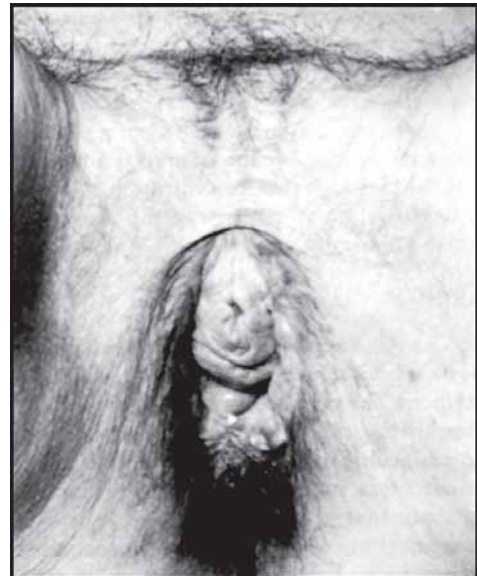
**Fig. 27.15:** Three-incision technique of vulvectomy. Modified hemivulvectomy with unilateral groin dissection has been tried in patients with an early well lateralised tumour, with no capillary or lymphatic space involvement and with negative ipsilateral inguinal nodes. However, patients with tumours involving the perineum, clitoris, vagina and labia minora have a high risk of contralateral lymph node metastases

There may be a small number of very carefully selected patients in whom it may be possible to perform only the local resection and omit even groin dissection. These are low-risk clinical stage I well-differentiated tumours which are unilateral with no evidence of capillary or lymph space involvement and up to 5 mm of invasion. Some have restricted this to an invasion of 1 mm. It must be noted that there are reports of 20 per cent groin node positivity with invasion up to 5 mm, so this method of treatment should be used with caution.

In view of the type of patient involved, a primary operative mortality rate of 1-3 per cent is likely but the overall results of radical vulvectomy for carcinoma of the vulva are good. The 5-year survival rate is 60-65 per cent of all cases treated and can be as high as 80-90 per cent in cases where the nodes are not involved. When they are, the survival rate falls to 25-45 per cent, the lower figure being obtained if the pelvic nodes are implicated. These assessments are based on a case operability rate of 90-95 per cent.

#### Radiotherapy

The vulvar tissues are unusually sensitive to ionising radiations, and a cancericidal dose produces a violent and persistent reaction in the surrounding skin. For this



**Fig. 27.16:** The ultimate distortion resulting from radical vulvectomy for cancer, even though not all the hair-bearing skin of the pubes was removed. Photograph taken 6 years after operation during which time the patient had a normal vaginal delivery

reason radiotherapy is not usually recommended. At present, radiotherapy is restricted to the following situations.

*Preoperative radiotherapy* is recommended for patients who are medically unfit for surgery; patients with advanced disease who are otherwise candidates for pelvic exenteration; young patients with small primary tumours, especially clitoral or periclitoral, who are psychologically unfit for surgical resection.

*Postoperative radiotherapy* is indicated for treating the groin if there are two or more positive lymph nodes; treating the pelvic lymph nodes; in patients with evidence of disease in an area  $\leq 5$  mm of the surgical margins. In all cases, therapy is aimed at preventing recurrences.

Improvements in radiotherapy techniques and the development of interstitial needles will further improve the scope of radiotherapy. Chemotherapy has been combined with radiotherapy to reduce the size of the tumour preoperatively in patients with central disease.

#### *Treatment of Recurrent Cancer of the Vulva*

Local vulvar recurrences correlate with the number of positive groin nodes ( $\geq 3$ ) and the size of the primary tumour ( $> 4$  cm). Local lesions can be excised and covered with a myocutaneous flap, e.g. the gracilis. Radiotherapy (external beam with interstitial needles) has also been used but may have the delayed sequelae of necrosis.

Regional and distant recurrences have a poor prognosis. Surgery and radiotherapy are used for recurrences in the groin. Chemotherapy is used for distant metastases.

#### *Diathermy Coagulation*

When the disease is advanced or the patient is old, quite good results can be obtained by fulgurating the growth with coagulation diathermy. This can be repeated if necessary to keep the growth and its offensive discharge in check.

#### **Basal Cell Carcinoma**

The vulva is an unusual site of this lesion (2% of vulvar malignancies) but, when it occurs, the features are similar to those of rodent ulcer of the face.

It is sometimes described as a type of intraepithelial neoplasia of the vulva. This it is not. A basal cell carcinoma is an *invasive* squamous cell growth which

penetrates into the dermis and deeper tissues seen most commonly on the labia. But its spread is slow and limited and it does not metastasise so it is nearly always cured by adequate local excision.

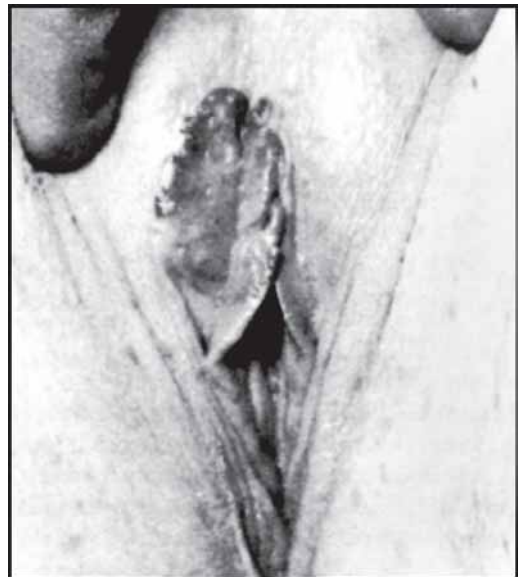
#### **Malignant Melanoma; Sarcoma**

These are among the rare tumours of the vulva but about 30 per cent occur premenopausally.

#### *Melanoma*

Melanoma is the second most common malignancy of the vulva. It shows varying degrees of malignancy; some are entirely benign, others virulent and metastasize quickly. It presents as a patchily or diffusely pigmented slightly raised area usually located on the labia (Fig. 27.17) or clitoris and is occasionally pedunculated. If malignant, it tends to ulcerate. The diagnosis can only be made by biopsy and, unless ulceration is present, this is indicated despite old arguments to the effect that it disseminates tumour cells.

The treatment, even for malignant melanomas, is generally by wide local excision or radical vulvectomy. Survival rates are good if the lymph nodes are negative, but all patients with positive nodes succumb to the disease.



**Fig. 27.17:** Melanoma of the vulva. The tumour is linear and affecting the right labium majus. On biopsy the melanoma was reported to be malignant. Further examination of the tissues after vulvectomy led to a conclusion that the condition was benign

### Sarcoma

Sarcomas represent 2 per cent of vulvar malignancies. They vary in type and malignancy, as they do elsewhere. The commonest are leiomyosarcomas. Other histologic types seen are rhabdomyosarcomas and epithelioid sarcomas. Rare variants include fibrosarcomas, neurofibrosarcomas, liposarcomas and malignant schwannomas. The appropriate treatment is by local excision; the lymph nodes should not be removed as sarcoma metastasises via the bloodstream. Rhabdomyosarcomas may be managed with chemotherapy, with or without radiotherapy.

### Metastatic Tumours

It is rare to see metastatic growths in the vulva but they can arise from any site and are usually blood-borne. For example, a small tumour of the vulva may prove to be the first evidence of recurrence of carcinoma of the breast treated surgically several years previously.

The vulva may be involved by non-Hodgkin's lymphoma or leukaemia. Other rare tumours include the endodermal sinus tumour, Merkel cell carcinoma and dermatofibrosarcoma protuberans.

## TUMOURS OF BARTHOLIN'S GLAND

### Bartholin's Cyst

#### Pathology

Bartholin's cyst is the commonest cyst of the vulva. There are two types: a cyst of the duct; and a cyst of the gland. They can only be distinguished on microscopic section, the difference being in their lining epithelium (Figs 2.4 and 27.18). The majority of cysts represent a dilatation of the duct, the gland itself lying closely adherent to the cyst on its posterolateral aspect. The typical content is glairy colourless Bartholin's gland secretion, although it is often brownish from contamination with old blood.

#### Aetiology

Cyst formation requires obstruction of the main duct or of the opening of an acinus. The cause of the obstruction is usually fibrosis which follows either infection or trauma. It was formerly believed that the infection was invariably gonococcal but almost any organism can be responsible. Moreover, the original Bartholinitis may be so slight as to pass unnoticed.

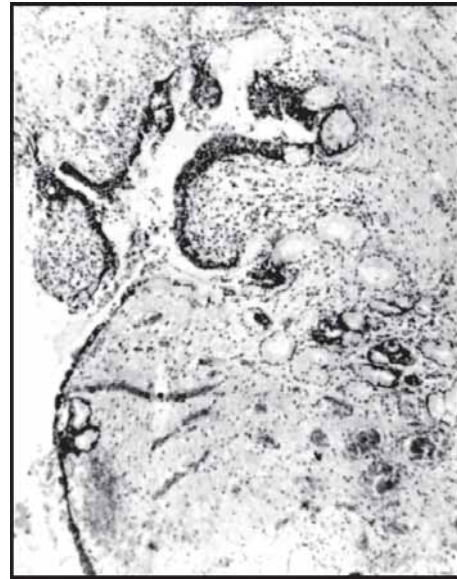


Fig. 27.18: Part of the wall of a cyst of Bartholin's duct lined by multilayered columnar epithelium. Acini of the gland can be seen alongside

Complete and sudden obstruction of the duct by division or ligation, which must happen frequently during operations and confinements, does not appear to be followed by cyst formation. The type of injury which operates is more in the nature of repeated minor friction. The left gland is more often affected than the right but both are often involved, not necessarily simultaneously.

#### Clinical Features

The cyst rarely exceeds the size of a hen's egg, and is often so small and symptom-free that it passes unnoticed by the examiner as well as the patient. If it is large, the woman becomes conscious of the swelling and it may interfere with coitus. The tumour is painless, non-tender and fluctuant and *its origin is determined by its position*. Like all swellings of Bartholin's gland or duct, it distends the posterior and middle parts of the labium majus and opens up the base of the labium minus. Its projection inwards makes the vulvar cleft S-shaped (Fig. 27.19).

#### Complications

Bartholin's cysts are liable to become secondarily infected; they then become acutely painful, throbbing and tender and present all the features of a Bartholin's



**Fig. 27.19:** A left-sided Bartholin's cyst showing the typical position with the base of the labium minus spread out over the dome of the tumour

abscess. When the pus has been released by simple drainage, the cyst usually reforms in a few weeks or months. Marsupialisation is the best way to avoid this.

#### Treatment

*Excision* of the cyst was the traditional treatment if symptoms were present, if the cyst was large, and if there was a history of its having been infected in the past. The operation is not so simple as might appear. The technical problems are haemorrhage from the extremely vascular tissues, and obliteration of the dead space. Unless these are adequately solved, haematoma formation leads to breakdown of the wound. To avoid this a tiny drain should be left for 24 hours. It is desirable to remove the gland as well as the cyst, and care is necessary to avoid injury to the vaginal wall. Fear of rupture of the cyst during dissection is groundless because the contents are invariably innocuous. Indeed, deliberate opening of the cyst makes dissection easier.

If the cyst is actively infected when the patient seeks advice it is not possible to excise it. It is then treated like acute bartholinitis.

To avoid the technical difficulties described above, and with the added advantage of preserving the function of the gland, simple incision into the cyst can be followed

by *marsupialisation* of the cut edges of its wall to those of the skin. This can be done no matter whether the cyst is infected or not, and gives a short convalescence with good prospects for a permanent cure. This type of operation now takes precedence over excision.

#### Neoplasms of Bartholin's Gland

These are exceptionally rare and are more likely to be malignant than benign. They take the form of a columnar cell adenoma or carcinoma. A malignant growth requires radical vulvectomy with block dissection of the inguinal glands on *both* sides.

#### URETHRAL TUMOURS

##### Prolapse of the urethra

###### Acute

*Acute urethral prolapse* is seen mostly in old age and in childhood, so lack of oestrogen may be a predisposing aetiological factor. The accident is often precipitated by straining at stool, coughing or crying. The whole circumference of the lower endourethra prolapses and becomes strangulated to form a purple-coloured tumour of variable size. The complaints are pain, dysuria and frequency of sudden onset; and sometimes reflex retention. After a few days the prolapsed tissue becomes ulcerated and may bleed. The diagnosis is usually easy although the condition may be confused with acute urethritis, caruncle, carcinoma and choriocarcinoma.

Treatment by replacing the prolapse and inserting a self-retaining catheter for several days may be curative in children, but in old women, it usually gives only temporary relief. In both, a better result can be obtained by the ligation of the extruded tissues around the catheter leaving them to slough away. The best treatment, however, is to amputate the prolapsed epithelium surgically, taking care not to allow the endourethral lining to retract, and to suture this to the external meatus.

###### Chronic

*Chronic urethral prolapse* is common in old age, when atrophy causes the external meatus to gape and allows some part of the urethral lining (usually the posterior rim) to project as a small tumour. This has the same red colour as the normal urethral epithelium. The condition is asymptomatic unless the exposed tissue becomes

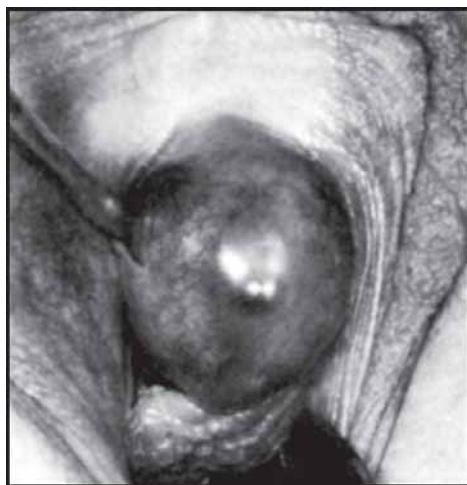
infected, when dysuria and frequency are likely. It has to be distinguished from other forms of urethritis and from caruncle and carcinoma.

No treatment is required unless symptoms are present; if they are, and this is rare, a plastic operation on the posterior aspect of the urethral meatus is an easy and satisfactory procedure.

### Diverticulum of the Urethra

A diverticulum with a narrow communication to the lumen of the lower urethra can result from: a congenital error; an abscess of the periurethral glands which bursts into the urethra; or obstetrical and surgical injury. It forms a swelling on any aspect of the urethra, but is most often posterior or postero-lateral. A posterior diverticulum projects into the vagina and from the introitus (Fig. 27.20). It can extend up the vaginal wall around the base of the bladder and its size varies according to whether it fills or empties itself of urine. The opening into the urethra is often valve-like so material cannot always be expressed. Infection is almost inevitable and calculus formation is not uncommon.

The likely symptoms are local discomfort, dysuria, dribbling of urine and dyspareunia. The condition has to be distinguished from a cyst of Gärtner's duct or of Skene's tubules, and from a urethrocele. The diagnosis of a urethral diverticulum is made by keeping the condition in mind: the urethral escape of pus or urine on pressure over the tumour; urethroscopy; and a lateral urethrography during voiding.



**Fig. 27.20:** A diverticulum of the urethra, the urethral meatus being indicated by a sound. The diverticulum filled and discharged intermittently. It was excised without difficulty and with a good result

Treatment is by excision of the diverticulum with closure of the small urethral defect, a procedure neither difficult nor dangerous if reasonable care is taken. It is important to carry out a histological examination of the tissue removed for, on rare occasions, carcinoma can develop in a diverticulum.

### Cysts of Skene's (Paraurethral) Tubules

Cysts form when the openings of these structures are blocked by previous infection. They present as small swellings low down on the anterior wall of the vagina rather than on the vulva (Fig. 27.21). The cyst can become infected to cause a *paraurethral abscess*. Treatment is by excision at a time when infection is quiescent.

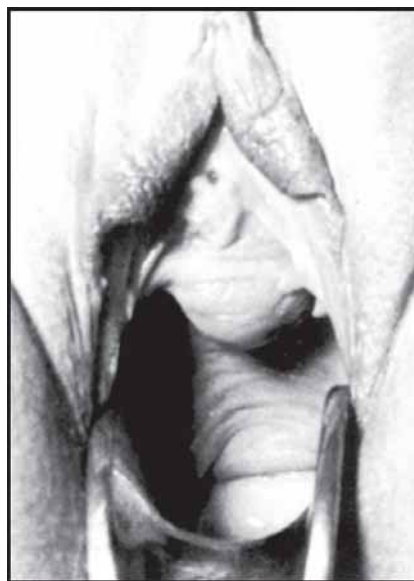
### Urethral Caruncle

The nature of this lesion was much disputed in the past but any remaining difficulty over its pathology, diagnosis and treatment, is caused by confusion between two conditions - a true caruncle and a chronic inflammatory reaction.

### True Caruncle

#### Pathology

A true caruncle is not so common as is generally supposed. It consists of a scarlet polyp which always *has*



**Fig. 27.21:** A cyst of Skene's (paraurethral) tubules, producing an irreducible tumour on the lower anterior vaginal wall

a narrow pedicle attached to the posterior margin of the urethral meatus. It varies in size from a pin-head to a pea; its colour indicates its extreme vascularity, which is also evident on section. The tumour is a papilloma of the urethra and is covered with transitional epithelium; this is arranged in folds and crypts which can give a false impression of malignant downgrowths (Fig. 27.22). In fact, caruncles are rarely malignant although they show a tendency to local recurrence. Microscopic examination also reveals that most caruncles are secondarily infected, and that some are well supplied with nerves.

#### Clinical Features

Caruncles arise at any age but generally after the menopause. Most but not all are exquisitely tender, so the patient complains of pain on sitting and walking, dyspareunia and dysuria. Other possible symptoms include slight bleeding and the presence of a swelling. The diagnosis rests on the colour, site and strictly localised polypoid nature of the tumour.

#### Treatment

To obtain a permanent cure it is necessary to make a wedge excision of the area from which the caruncle arises, including the tumour itself. Moreover, the site



**Fig. 27.22:** A true urethral caruncle showing its essentially papillomatous structure with some secondary leucocytic infiltration of the connective tissue. The transitional epithelium is arranged in folds which, on section, give the false impression of downgrowths

should then be coagulated with a cautery or diathermy. Thereafter, it is preferable to cover the area with epithelium brought in from the sides.

#### 'Granulomatous Caruncle' or 'Diffuse Caruncle'

##### Pathology

This non-neoplastic, non-polypoidal condition is much more common and is often mistakenly labelled and treated as a caruncle. It is a granulomatous lesion affecting the external urethral meatus, notably on its posterior lip but extending round the sides. Although the margin of the urethral opening is raised and pouting, the 'tumour' is without a pedicle, is dull red rather than cherry red, and not so tender as a caruncle. On section it shows the usual histological features of tissue reaction to chronic infection.

A granulomatous caruncle is a relatively localised form of chronic urethritis; it may sometimes be nothing more than secondary infection of a slightly prolapsed endourethra, possibly associated with senile vaginitis. In the majority of cases, however, it is a manifestation of a chronic *Trichomonas* infestation. This possibility should be excluded in all cases by culture of material taken from the urethra and vagina.

Since the lesion is a response to infection, and is not clearly demarcated, it usually recurs after excision or cauterisation and this mostly explains why caruncles in general have an evil reputation in this respect.

##### Clinical Features

The symptoms produced are similar to those of caruncle but they are not so bothersome.

##### Treatment

It is essential to determine the type of infection present and to treat it accordingly. Even when the presence of *Trichomonas vaginalis* organisms is not confirmed, a prolonged and intensive course of treatment with metronidazole should always be given empirically. Postmenopausal patients sometimes benefit from oestrogen therapy, applied locally or in the form of vaginal pessaries. Local applications of antiseptic preparations can also be of help. In longstanding cases it may be necessary to excise the affected area. Cauterisation or diathermy coagulation without excision always gives unsatisfactory results.

### Other Urethral Papillomas

These take the form of small skin-coloured pedunculated tags arising from just within the external urethral meatus (Fig. 27.23). Occurring at all ages, sometimes in childhood, they are usually symptomless but can cause local discomfort. They are easily treated by excision.

### Carcinoma of the Urethra

#### Pathology

The urethra can be involved in the direct extension of a cancer of the vulva. Primary carcinoma of the urethra is rare and most gynaecologists see not more than five or six cases in a lifetime. Although an adenocarcinoma of the paraurethral glands is a possibility, most tumours are epidermoid and arise from the transitional epithelium. The growth nearly always develops low in the urethra so its lymphatic dissemination is the same as that of carcinoma of the vulva.

#### Clinical Features

The usual complaints are dysuria, frequency and haematuria, and sometimes bleeding apart from micturition. Urinary retention is a late symptom. Unless the growth is fungating at the meatus, the only physical sign is palpable enlargement and hardening of the urethra as judged by rolling it against the symphysis



**Fig. 27.23:** A bilobed papilloma arising from the posterior margin of the urethral meatus. This might be regarded as a true caruncle but the tumour was fleshy coloured, not red, and was symptomless

pubis. The diagnosis is made certain by histological examination of urethral scrapings and by biopsy.

#### Treatment

Each case has to be treated according to its circumstances (Fig. 27.24), the possibilities being: insertion of radium needles as a palisade around the urethra, with or without inguinal lymphadenectomy; excision of the urethra (and possibly the bladder) together with the anterior vaginal wall, the adjacent parts of the vulva and the inguinal nodes - this also involves transplantation of the ureters; local excision of the growth; and combinations of surgery and radiotherapy.

The majority of carcinomas in the distal half of the urethra are treated by local excision or radiotherapy. The 5-year survival rate is 30-50 per cent.

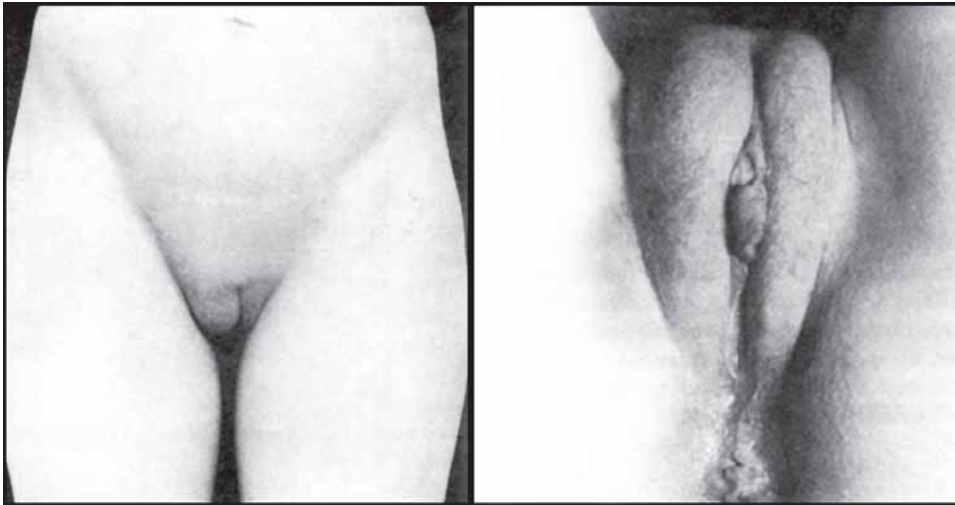
### TUMOURS OF THE INGUINAL CANAL

An obliterated peritoneal pouch extends down the inguinal canal with the round ligament. A *hydrocele of the canal of Nuck* is a fluid distension of a portion of this rudimentary structure, and may present as an irreducible



**Fig. 27.24:** Carcinoma of the urethra which involved the inferior ramus of the pubis. A catheter marks the lumen of the urethra. This photograph was taken after radiotherapy covering the whole of the urethra and this has destroyed the foreparts of the labia minora and caused necrosis of the growth. The lesion, together with the urethra and the lower part of the bladder, was subsequently excised, the ureters being transplanted into the colon. The patient survived for another 7 years





**Fig. 27.25:** A right-sided inguinal hernia presenting as a tumour of the labium majus

cystic swelling in the forepart of the labium majus. It has to be distinguished from an inguinal hernia which also can extend far into the labium (Fig. 27.25). A *fibroma or endometriosis of the round ligament* can give rise to a hard swelling at the insertion of the ligament into the

subcutaneous tissues of the mons, the endometrioma having a characteristic behaviour. A *varicocele of the round ligament* is mostly seen during pregnancy and simulates an inguinal hernia; active treatment for it is rarely necessary.

Swellings of the Vagina	456
Vaginal Cysts	456
Benign Neoplasms	458
Malignant Neoplasms	459

## SWELLINGS OF THE VAGINA

A complaint of swelling or fullness in the vagina may be caused by the following:

- Retained fluid - haematocolpos, pyocolpos
- Prolapse of the vaginal walls or uterus
- A congenitally short vagina with a relatively low cervix
- Varicose veins which are usually low on the anterior wall and are mostly seen during pregnancy
- Vaginitis of any kind
- Tumours of the urethra
- Enlargement of the cervix
- Any tumour which is impacted in the pelvis
- Vaginal cysts
- Benign neoplasms
- Malignant neoplasms

This chapter is concerned with the last three groups of conditions; the others are described elsewhere.

## VAGINAL CYSTS

Since the vaginal epithelium is normally devoid of glands, most cysts arise from included or adjacent structures. Their nature and origin are therefore determined clinically by their position.

### Cysts of Vestigial Structures

#### Types

##### *Müllerian*

Tiny cysts, single or multiple, lined by tissue similar to that of the cervical epithelium and containing mucinous material, sometimes occur near the cervix. They are thought to arise from displaced cervical glands or from müllerian duct diverticula and their remnants.

*Wolffian*

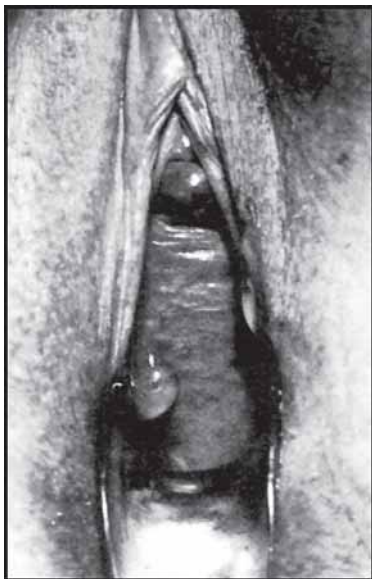
The majority of vaginal cysts arise from Gärtner's duct; their origin is deduced by their position on a line running down the lateral or anterolateral wall of the vagina from the cervix to the region of the urethra and clitoris (Figs 14.11 and 28.1). The cysts are usually small and multiple but can attain the size of a foetal head; in the lateral fornix they are in close association with the ureter. Their lining is a single layer of flattened columnar or cuboidal epithelium, but can be transitional; their fluid content is free from mucin (Fig. 28.1).

*Others*

Midline cysts in the posterior vaginal wall may arise from the remains of the tongue of coelom (Fig. 28.2).

**Clinical Features**

Small cysts are usually symptomless, large ones cause dyspareunia, infertility, dystocia or a sensation of fullness in the vagina. They are distinguished from a urethrocele, cystocele, urethral diverticulum and other cysts by their position; by the fact that they do not disappear with pressure or with change in posture; and by demonstrating with a sound or other means that they do not communicate with the bladder or urethra. It can be



**Fig. 28.1:** A cyst in the anterolateral wall of the vagina probably arising from the remnants of the wolffian duct, as judged from its site

difficult to distinguish a vaginal cyst from a paravaginal lipoma, soft fibroma and myxoma.

**Treatment**

Asymptomatic cysts discovered incidentally do not require treatment. Otherwise, they are excised. If, however, the cyst is large and near the ureter or the bladder it is safer to remove its top and to marsupialise its base to the vaginal wall; the lining epithelium then quickly assumes the characters of that of the vagina.

**Cyst of Skene's Tubules**

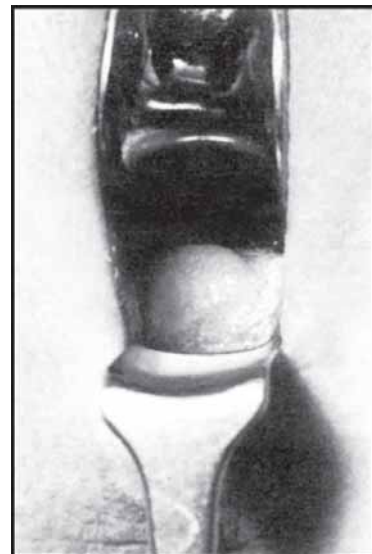
See page 452.

**Diverticulum of Urethra**

See page 452.

**Epidermoid Cyst; Implantation Dermoid**

These arise from accidental implants of fragments of sebum-producing skin, such as that of the perineum (see page 442). They therefore usually follow obstetrical injuries or perineorrhaphy and their only common vaginal site is the lower part of the posterior wall. These cysts cannot develop from implants of vaginal epithelium (which does not secrete sebum). They are small and rarely produce symptoms or require treatment.



**Fig. 28.2:** A cyst in the lower part of the posterior vaginal wall or a nulliparous woman complaining of infertility. It was asymptomatic and was therefore not removed. So its pathology remains uncertain. The midline site suggests a developmental inclusion cyst

## Endometriotic Cysts

These can arise in scars in any position in the vagina; otherwise they are mostly seen in the posterior fornix in association with endometriosis of the rectovaginal septum or in episiotomy scars.

## BENIGN NEOPLASMS

Benign neoplasms of the vagina may be sessile or pedunculated. Some are paravaginal rather than vaginal, in that they arise from tissue in the paracolpos.

### Types

#### *Papilloma*

True papillomas (including multiple warts) do occur (*see* Chapter 19), but most tumours of this type are skin tags remaining from obstetrical injuries or operations.

#### *Angioma*

An angioma is a congenital malformation of the blood vessels usually seen under the lateral walls.

#### *Adenoma*

This rare tumour arises in association with Gartner's duct and has therefore an anterolateral site. The lesions are often small and multiple. When they occur in children they are sometimes confused with carcinoma.

#### *Adenosis*

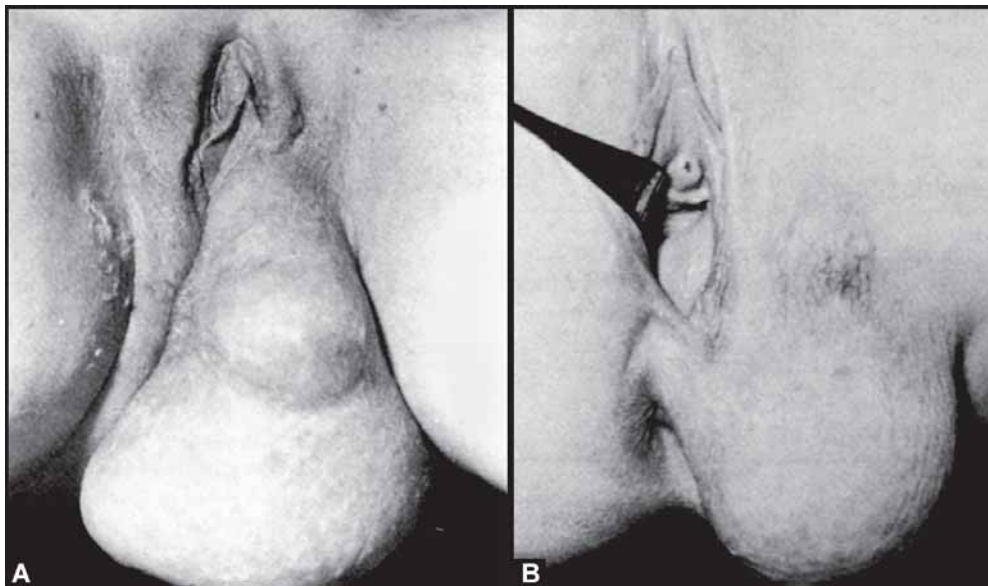
See page 409.

#### *Fibroma and Lipoma*

These arise from the outer coats of the vagina or from the paracolpos. They can reach large dimensions and can extend into the broad ligament and into the ischio-rectal fossa.

#### *Myxoid-soft Tissue Tumours*

These are soft, fluctuant, almost cystic tumours containing myxomatous and fibrous or fatty tissue elements. The common sites are the ischio-rectal fossa and the subcutaneous tissue of the buttock. But they are also seen arising in, or extending to, the paracolpos (Figs 28.3A and B). They do not metastasise but are



**Figs 28.3A and B:** A paravaginal fibromyxoma in a multiparous woman aged 35 years (A) The original tumour when excised, proved to extend from the vulva through the ischio-rectal fossa to the paracolpos (photograph presented by Mr E Parry Jones) (B) A recurrence of the tumour 3 years after its removal. The upper pole extended into the base of the left broad ligament. Its extent, and the fact that the myxoma was soft and poorly encapsulated, made excision very difficult. A further recurrence seemed likely but the after history of this case is unknown

locally recurrent and may ultimately become frankly sarcomatous.

### *Granuloma*

Discrete and often polypoidal areas of granulation tissue are not uncommonly found in vaginal scars - especially those following colporrhaphy and total hysterectomy. They are not neoplasms but they sometimes persist for months and years after operation and can be mistaken for malignant disease.

### Clinical Features

Small tumours are symptomless unless they become ulcerated and infected; they then cause contact bleeding and discharge. Large tumours cause dyspareunia, infertility, bladder irritability, rectal pressure and tenesmus, and obstructed labour.

### Treatment

Local excision is generally indicated. This is usually easy, but can be very difficult if the tumour is large, vascular, and extending into the broad ligament.

## MALIGNANT NEOPLASMS

### Primary

The majority, i.e. 92 per cent of primary vaginal cancers, are reported to be squamous cell carcinomas. Other tumours seen are the clear cell adenocarcinomas, malignant melanomas, embryonal rhabdomyosarcomas and endodermal sinus tumours.

### Vaginal Intraepithelial Neoplasia (VAIN)

For patients with an abnormal pap smear and no gross abnormality, vaginal colposcopy and use of Lugol's iodine to stain the vagina are necessary. Excision of colposcopically abnormal areas is usually necessary under anaesthesia. This is particularly true for lesions involving the vaginal vault, where occult carcinoma may be found in up to 28 per cent of patients with VAIN.

Treatment of VAIN is individualised and depends on the extent, location and general medical condition of the patient. Numerous treatment methods, ranging from the various methods of local tissue destruction or ablation through to more extensive surgery and including total vaginectomy, as well as intracavitary radiotherapy have

been used to treat VAIN. Selection of appropriate treatment is usually based on a careful study of several factors, including the general medical condition of the patient, histology of the lesion, and location and extent of disease, as well as the experience of the treating surgeon with the specific treatment methods. The proximity of the urethra, bladder and rectum to the vaginal epithelium is an important factor to be considered, particularly when local destructive or surgical excision methods are used. Damage or injury to these structures can occur with possible fistula formation, particularly when the patient has had prior radiation therapy.

The use of topical 5-fluorouracil (5-FU) is a relatively simple ambulatory treatment, which does not require anaesthesia or complicated equipment. This approach may be especially valuable for patients with widespread of multifocal lesions, which would require extensive surgical procedures. Side effects with this therapy during treatment are usually minimal as long as it is not used more than twice a week. Imiquimod cream 5 per cent might represent an alternative method of management in young, HPV positive women with multifocal high-grade lesions. (VAIN 2/3).

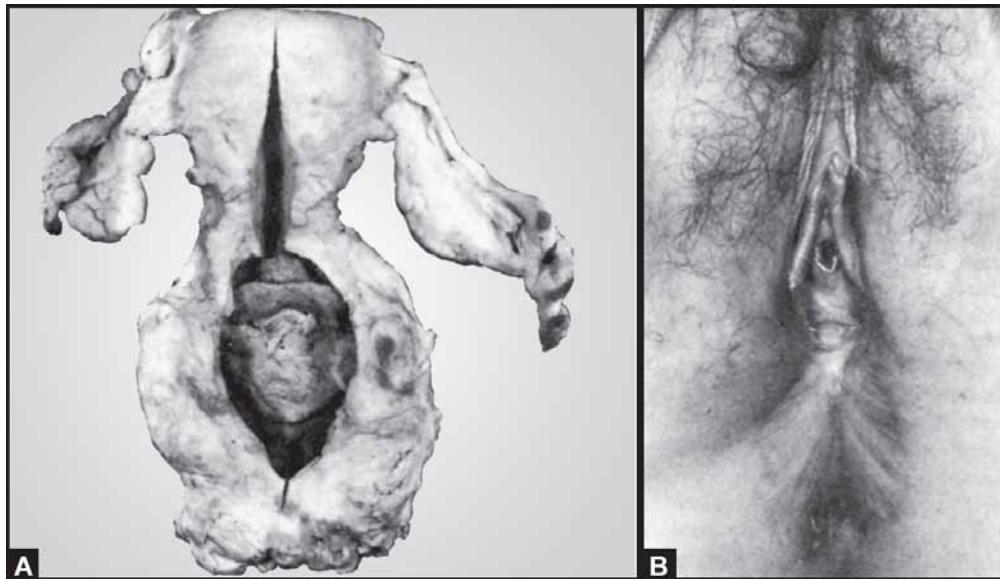
Laser vaporisation with a CO<sub>2</sub> laser is an effective treatment for VAIN. This technique generally requires local or general anaesthesia.

Excisional procedures either with electrosurgical loops or a scalpel excision have also been used to treat VAIN. Surgical excision is particularly appropriate for vault lesions. Also on occasion, total vaginectomy and split thickness skin grafting may be necessary to treat extensive lesions that involve virtually the entire length of the vaginal tube and where other conservative methods have been unsuccessful.

### Squamous Cell Carcinoma

#### *Incidence and Aetiology*

Primary invasive squamous cell carcinoma of the vagina is rare and is found only once for every 30-50 cases of carcinoma of the cervix, accounting for only 1-2 per cent of genital malignancies. The growth usually begins high on the posterior vaginal wall opposite to the external os (Figs 28.4A and B) and this, in the past, gave rise to a suggestion that it is caused by irritating discharges from the cervix. Longstanding prolapse or the prolonged wearing of a pessary could also determine neoplastic change. In the past, a history of exposure to a pessary,



**Figs 28.4A and B:** (A) A specimen of carcinoma of the upper posterior vaginal wall obtained by abdominoperineal excision of all the internal genital organs and the rectum (posterior extenteration) (B) The local result 6 months after operation. The patient concerned died from metastases 18 months later

not necessarily a neglected one, was obtained in 25 per cent of cases. In these the disease sometimes had an annular distribution.

Since the vagina is thin walled, the growth quickly involves adjacent organs and the prognosis is therefore poor.

#### *Spread*

Carcinoma of the vagina spreads by direct extension to the bladder, the rectum, the cellular tissues of the uterosacral and broad ligaments, the cervix and the vulva. When the growth is in the upper vagina, the lymphatic spread is the same as in carcinoma of the cervix; if it is situated lower, the vulvar as well as the cervical lymphatic drainage fields are implicated. This explains why the higher growths justify a slightly better prognosis.

#### *Clinical Features, Diagnosis and Staging*

The patient suffering from invasive squamous carcinoma of the vagina is usually over the age of 40 years and mostly within the range of 60-80 years. Her symptoms are irregular bleeding, contact bleeding and offensive discharge. The diagnosis is made by seeing and feeling the malignant growth. This usually takes the form of an ulcer with a hard base and raised edges, which becomes

fixed to underlying structures at an early stage. Its surface is friable and bleeds easily on touching.

Carcinoma of the upper vagina has to be distinguished from vault endometriosis and granulo-matosis, from malignant disease of the rectum, and from a primary growth on the cervix. When the lower vagina is involved it can be difficult to say whether the lesion is primary in the vagina or in the vulva. For the purpose of international consistency in recording it is recommended that any growth which involves the cervix should be classified as cervical and not vaginal.

To be classified as a primary vaginal cancer, there must be no clinical evidence that the vaginal tumour is metastatic.

Diagnosis is made by a generous, full thickness biopsy and histopathology. Colposcopy identifies coexisting vaginal intraepithelial neoplasia (VAIN), if any, and helps in planning treatment.

The four-stage FIGO classification of invasive carcinoma is as follows (Table 28.1):

- Stage 0** : Carcinoma *in situ*
- Stage I** : Invasive carcinoma limited to the vaginal mucosa
- Stage II** : Carcinoma has involved the subvaginal tissues but not extended onto the pelvic wall

**Stage III** : Carcinoma has extended onto the pelvic wall

**Stage IVA** : Carcinoma has involved the bladder or the rectum

**Stage IVB** : Carcinoma has extended beyond the true pelvis.

Cystoscopy, proctosigmoidoscopy, chest X-ray and intravenous pyelography are required for assessing the spread of the disease. Transrectal ultrasound and MRI can be useful in assessing the extent of the lesion.

The upper two-thirds of the vagina is drained by lymphatics to the pelvic nodes, with the lymphatics paralleling the course of the uterine artery and the vaginal artery to the obturator, hypogastric and external iliac nodes. The lower third of the vagina drains to the inguinal-femoral nodes. Some lesions may drain via pararectal lymphatic channels.

*Histopathologic Grades (G)*

- Gx — Grade cannot be assessed
- G1 — Well differentiated
- G2 — Moderately differentiated
- G3 — Poorly or undifferentiated.

*Regional Lymph Nodes (N)*

- NX — Regional lymph nodes cannot be assessed
- N0 — No regional lymph node metastasis.

*Distant Metastasis (M)*

- MX — Distant metastasis cannot be assessed
- M0 — No distant metastasis
- M1 — Distant metastasis.

**Treatment**

*Invasive Carcinoma*

Patients should all be referred to referral units, because of the limited experience with these lesions. All treatment must be individualised, and will vary depending on the stage of disease and the site of vaginal involvement.

**Surgery**

Surgery has a limited role because of the close proximity of the bladder and rectum, but may be useful in the following situations.

1. *In patients with Stage I disease involving the upper posterior vagina.*

If the uterus is still *in situ*, radical hysterectomy, upper vaginectomy to achieve clearance of at least 1 cm, and pelvic lymphadenectomy may be performed, while if hysterectomy has been previously performed, radical upper vaginectomy and pelvic lymphadenectomy may be appropriate.

2. *In young patients who require radiation therapy.*

Pre-treatment laparotomy may allow ovarian transposition, surgical staging and resection of any bulky positive lymph nodes.

3. *In patients with Stage IVA disease, particularly if a recto-vaginal or vesico vaginal fistula is present.*

Primary pelvic exenteration is a suitable treatment option for such patients, either combined with pelvic lymphadenectomy or pre-operative radiation.

Bilateral groin dissection should be considered in such patients if the lower third of the vagina is involved.

4. *In patients with a central recurrence after radiation therapy.*

Surgery will usually necessitate some type of pelvic exenteration in such patients.

**Radiation Therapy**

Radiation therapy is the treatment of choice for most patients with vaginal cancer, and comprises an integration of teletherapy and intra-cavitary/interstitial therapy.

Selected cases of Stage I and II lesions can be treated adequately with intracavity radiation alone. For larger lesions, treatment is usually started with approximately 5000 cGy external radiation to shrink the primary tumour and treat the pelvic nodes.

Intracavitary treatment follows. There is improved local control with total tumour doses of at least 7000 Gy.

If the lower one-third of the vagina is involved, the groin nodes should be treated or dissected.

**Table 28.1: Carcinoma of the vagina — Stage Grouping**

FIGO stage	UICC		
	T	N	M
I	Tis	N0	M0
II	T1	N0	M0
III	T1	N1	M0
	T2	N1	M0
	T3	N0	M0
	T3	N1	M0
IVA	T4	Any N	M0
IVB	Any T	Any N	M1

There is limited reported experience with chemoradiation for vaginal cancer. However in view of the problem with control of the central disease, the concurrent use of 5-fluorouracil and/or cisplatin may be appropriate.

### Adenocarcinoma

A vaginal adenocarcinoma can arise in relics of the wolffian duct and then has the histological features of a clear cell adenocarcinoma (see below). It is extremely rare and, when it does occur, forms a tumour deep to the lateral vaginal wall - the position of the tissue of origin. The clinical features and management are as for squamous cell carcinoma.

Adenocarcinoma can also be of müllerian duct origin arising possibly in misplaced cervical glands, but more likely as a result of metaplasia or as a consequence of the potential for müllerian duct tissue to differentiate in different ways.

A special form of this type of adenocarcinoma has appeared in the last three decades and, because of its histological features, is designated the clear cell adenocarcinoma. The large clear cells contain glycogen, the nuclei have a hobnail appearance and the malignant cells are arranged in clumps and in tubules suggestive of renal carcinoma. The tumour is not a mesonephroma or of wolffian duct origin because it usually arises high on the anterior vaginal wall and it is very superficial, often polypoidal.

This condition is found in girls less than 25 years of age, mostly in their early teens, and in 80 per cent of cases there is a history of exposure *in utero* to oestrogens which were administered to their mothers before the eighteenth week of pregnancy. The oestrogens have all been of the synthetic non-steroidal type, mostly diethylstilboestrol. In 80 per cent of cases there is associated vaginal adenosis and the lesions, benign or malignant, are often multiple (see page 409 and Chapter 13). There is also usually cervical ectopy. Another common associate, indicative of interference with müllerian duct development, is congenital transverse ridging and stricture of the upper vagina.

It is reckoned that less than 1 in every 1000 girls exposed to the oestrogen influence *in utero* develops a clear cell adenocarcinoma of the vagina or cervix.

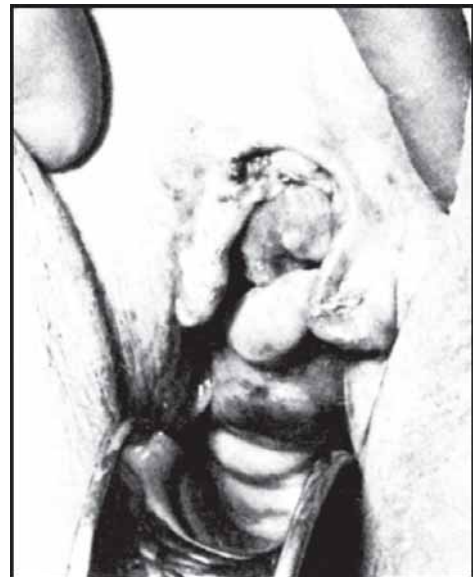
Clear cell adenocarcinoma of the vagina may be symptomless but, if the surface is ulcerated, the girl complains of bleeding and discharge. Vaginal cytology gives negative findings in 20 per cent of cases.

Bearing in mind the young age of the patient and the superficial site of the growth, local excision followed by measures described for vaginal adenosis is often the best treatment. However for multiple lesions, vaginectomy and even more radical procedures have been carried out. Most are located in the upper vagina and are treated as cervical lesions. Radiotherapy by itself gives poor results. Those for surgery alone cannot yet be assessed although 20 per cent of patients are known to die within 2-3 years of operation. In many cases, combinations of radiotherapy and radical surgery have been used.

### Melanoma

The origin of the melanoma is disputed. Some consider that a vaginal tumour of this type is always secondary to a lesion elsewhere. Others postulate a primary development as a result of metaplasia or misplacement of mesodermal and epithelial tissues (Fig. 28.5).

Melanoma of the vagina is rare and carries a poor prognosis (5-year survival rate 7%), depending on the depth of the epithelial invasion. Its clinical features and treatment are similar to those of squamous cell carcinoma of the vagina; however, treatment is ineffective if it is deeply invasive as it metastasises early through the bloodstream. It does not respond to chemotherapy.



**Fig. 28.5:** Multiple melanomas of the anterior wall of the vagina in a woman aged 79 years. The lymph nodes in both groins were involved but no evidence of an extragenital primary was found. Only palliative treatment was possible



## Sarcoma

Sarcoma botryoides is a highly malignant tumour of the rhabdomyoblasts. These neoplasms are found in infants and children and usually present with discharge, bleeding or a visible mass at the introitus.

In the past, exenterative surgery was used for these lesions, but survival was poor. More recently, conservative surgery has been used in conjunction with pre-operative or post-operative chemotherapy and radiotherapy with significantly improved survival. Most reported chemotherapeutic experience has been with Vincristine, Actinomycin D and Cyclophosphamide (VAC).

If the lesion is small and can be resected with organ preservation, surgery should be the initial approach. For bulkier lesions, pre-operative chemo or radiotherapy should be given.

Extended radiotherapy fields are not recommended as they may produce significant developmental problems with the bony pelvis by destroying or interfering with growth centres in these structures.

### *Secondary*

Malignant disease of the vagina is usually secondary to a primary growth elsewhere. The mechanisms of spread are as follows.

## Direct Extension

This occurs from the cervix, vulva, urethra, bladder, rectum and occasionally from malignant deposits in the pouch of Douglas which invade the posterior fornix.

## Blood and Lymphatic Spread

Secondary carcinoma often takes the form of isolated nodules which, although they occur anywhere, are nearly always disposed low in the anterior vaginal wall, i.e. suburethrally or in the fornices. This is especially noticeable when the primary is a chorio-carcinoma and an adenocarcinoma of the body of the uterus or of the fallopian tube. The site is explained by direct connections through the azygos veins and lymphatics; spread is due to embolism.

Metastases can arise from any organ. Vaginal metastases are particularly likely in renal carcinoma; in such cases the primary is more often in the left than the right kidney because the left ovarian vein opens into the left renal vein.

## Seeding

Carcinoma secondary to growth in the body of the uterus, occurring after hysterectomy, is occasionally caused by detached fragments of growth becoming implanted into the vaginal vault or elsewhere.

# CHAPTER 29

## Tumours of the Cervix Uteri

Enlargements of Cervix	464
Cysts of the Cervix	464
Benign Neoplasms	465
Carcinoma of the Cervix	467
Other Malignant Tumours of the Cervix	486

### ENLARGEMENTS OF CERVIX

*The causes of enlargement of the cervix are :*

- 'Congenital' hypertrophy
- Haematocervix associated with atresia
- Hypertrophy or elongation of the supravaginal cervix associated with prolapse
- Congestion and oedema of the vaginal portion of the cervix associated with
  - Prolapse
  - Pregnancy
  - Cervicitis
- Syphilis
- Tuberculosis
- Glandular hyperplasia and hypertrophy associated with chronic congestion due to any cause
- Partial extrusion of a uterine tumour
- Cervical pregnancy
- Endometriosis, endocervicosis
- Mucous polyp
- Cyst formation, especially multiple nabothian follicles
- Benign neoplasms
  - Leiomyoma
  - Others - angioma, papilloma
- Malignant neoplasms
  - Squamous cell carcinoma Adenocarcinoma Sarcoma
  - Others - melanoma, metastases

Only the last three groups are considered in this chapter. The others are described elsewhere.

### CYSTS OF THE CERVIX

#### Cysts of Embryonic Tissues

Wolffian duct cysts similar to those in the vagina are found in the sides of the cervix. Cervical cysts can also arise from diverticula of the müllerian duct. Sometimes

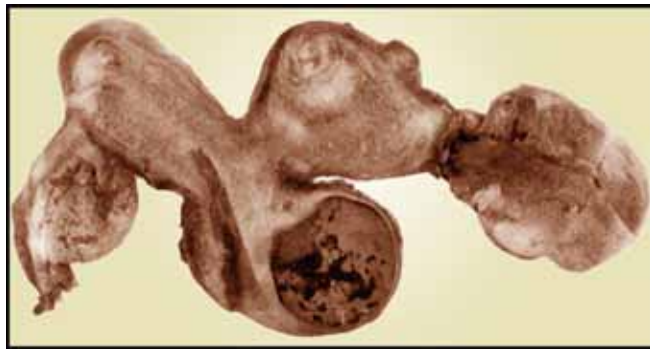
they represent the rudimentary and incompletely canalised cervix of a bicornuate uterus (Fig. 29.1).

### Endometriotic or Endocervicotic Cysts

#### Nabothian Follicles or Cysts

##### Pathology

A few small retention cysts of cervical glands of the cervix can be found in the majority of multiparae, and sometimes even in virgins; only if they are numerous or large is the condition pathological. They rarely exceed the size of a grape and are usually only a few millimetres



**Fig. 29.1:** A bicornuate uterus with a large blood cyst in the cervix and a haematosalpinx on the same side. There appears to be only one cervix but the collection of blood possibly represents retention of menstrual discharge in a second, imperforate cervix

in diameter. A Nabothian cyst arises when the duct of a gland becomes obstructed by injury, fibrosis or a plug of epithelial debris. The cyst is lined by columnar cell epithelium (sometimes flattened by intracystic pressure) and contains clear mucus (Figs 20.6 and 29.2A and B).

##### Clinical Features

Retention cysts of the cervix do not in themselves ordinarily cause symptoms, although large ones in a cervical stump may cause aching pain while they are filling; this is relieved when the cyst bursts and discharges a quantity of mucus or mucopus. This is rare and, ordinarily, any complaints are those produced by an associated chronic cervicitis.

Cysts near the surface of the cervix appear as silvery-bluish or yellowish mounds but they feel so hard that they are often mistaken for small leiomyomas.

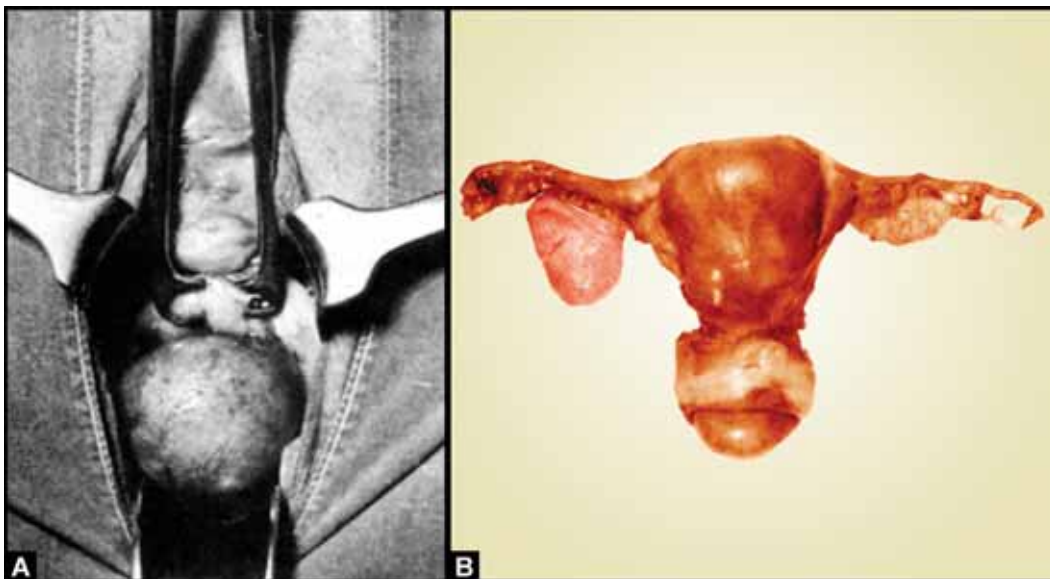
##### Treatment

The treatment is the same as for chronic cervicitis.

## BENIGN NEOPLASMS

### Papilloma

Single papillomas and multiple condylomata acuminata are sometimes found on the cervix. But most 'tumours'



**Figs 29.2A and B:** An unusually large glandular retention cyst (Nabothian follicle) of the cervix, (A) The cyst projecting through the external os might be mistaken for a leiomyomatous polyp, (B) Operation specimen from the same case. The cyst was asymptomatic and hysterectomy was performed for recurrent perimenopausal bleeding

in the group are epithelial tags remaining from obstetrical and surgical injuries and enlarged by congestion and oedema.

Irrespective of their type, cervical papillomas may be symptomless or may cause discharge which becomes bloodstained if they are ulcerated. They are treated by surgical removal.

### Angioma and Allied Tumours

Haemangiomas of the cervix are seen as small superficial lesions but are rare. Their growth is said to be encouraged by pregnancy. Although usually asymptomatic they can cause irregular bleeding.

Treatment is by local excision, diathermy coagulation or laser.

### Adenoma: Adenofibroma

#### Pathology

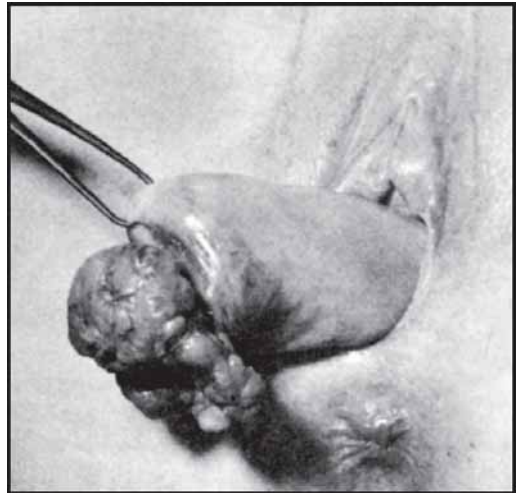
A true adenoma of the cervix usually takes the form of a mucous polyp and is extremely common (Fig. 29.3). It arises from the endocervix, often as high as the internal os, but has a long and narrow stalk which allows it to project from the external os. Indeed, the tumour sometimes hangs outside the vulva. The tip becomes necrotic and infected. Cervical polyps are frequently branched or there may be two or three separate tumours.

It is said that their development is encouraged by chronic cervicitis or a response to a virus.

The histological picture is one of cervical glandular tissue with a variable amount of connective tissue (Figs 29.4A and B). In pregnancy the latter undergoes decidual reaction. When connective tissue predominates the tumour is sometimes described as a fibroadenoma. The outer covering can be columnar epithelium but often it is squamous; the latter represents metaplasia rather than a contribution from the portio. Reactive changes or cervical intraepithelial neoplasia are sometimes seen in this epithelium. Cervical polyps nevertheless tend to recur.

#### Clinical Features

Adenomatous cervical polyps arise at any age, sometimes even in childhood. Many are asymptomatic and are only discovered on routine examination. When symptoms are present the main one is vaginal discharge, mucoid or mucopurulent, which becomes bloodstained



**Fig. 29.3:** A large polyp projecting from the cervix of a woman suffering from uterine prolapse. Its covering is thick and pale, consisting of squamous epithelium. Beneath this the tumour was composed of cervical adenomatous tissue

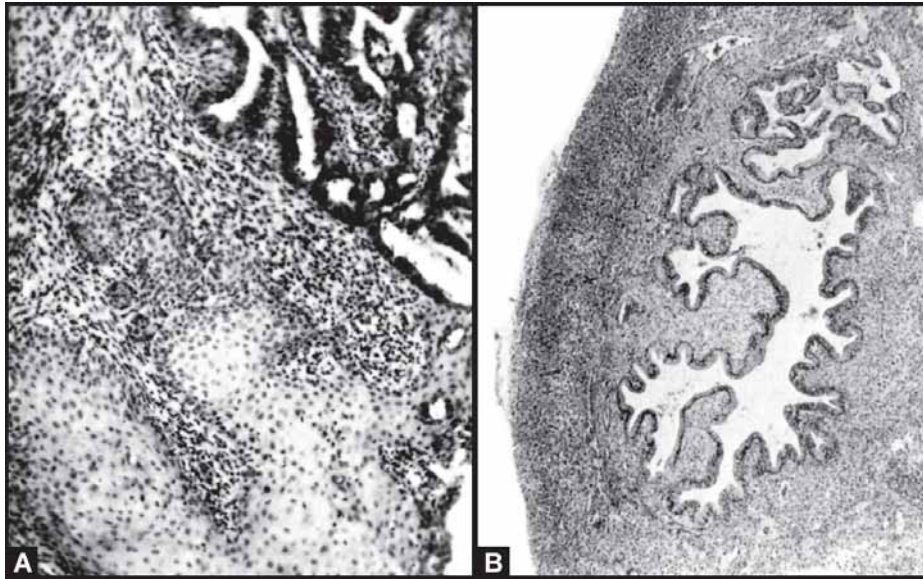
when the polyp is ulcerated. Bleeding on coitus is sometimes a complaint and, if the stalk is long, the patient may notice the tumour.

A mucous polyp is soft and fleshy, and is easily missed by the palpating fingers and if the cervix is not inspected. Another trap in diagnosis is that the tumour can periodically retreat within the cervical canal; so it may not be even visible at the time of examination. A polyp covered by columnar epithelium is dull red, fragile, and bleeds easily when touched. One covered by squamous epithelium is pale, more robust and less likely to cause symptoms.

The differential diagnosis is from an ectopy, a polypoid hyperplasia ('pill ectopy') of the endocervix caused by the contraceptive pill, a Nabothian follicle, a cervical tag, ectropion, carcinoma, a uterine polyp protruding through the cervix, blood clot and partially extruded products of conception.

#### Treatment

Every cervical polyp should be removed and sectioned, even if it is symptomless, except in pregnancy. The tumour is easily avulsed, or removed by cutting its stalk, but its base should be cauterised if the very real risk of recurrence is to be reduced. Dilatation of the cervix and curettage should be carried out at the same time. This is to get to the base of the stalk which is often high in the



**Figs 29.4A and B:** (A) Microphotograph of a cervical polyp showing the typical glandular structure with the squamous epithelial covering alongside, (B) The tip of an adenomatous cervical polyp covered by squamous epithelium and showing surface inflammatory reaction

endocervix, to catch any additional polyps within the cervical canal, and to exclude another intrauterine source for the discharge such as carcinoma. Hysteroscopy is even more accurate for this purpose. It also makes it possible to be sure that the polyp is arising from the cervix and not from within the body of the uterus.

### Leiomyoma

Leiomyomas in the supravaginal cervix are considered in Chapter 30. In the vaginal cervix they are comparatively rare but are seen as interstitial or submucous (polypoidal) growths (Figs 30.9 and 30.11). Most leiomyomatous polyps seen at the external os, however, arise within the uterus and are merely extruded through the cervix.

A sessile myoma of the cervix can be shelled out of its capsule; a pedunculated one is removed by division of its stalk.

### CARCINOMA OF THE CERVIX

The cervix is the commonest site for female genital cancer. Among women dying from malignant disease of all kinds, the cervix is the organ primarily involved in 5 per cent. Statistics vary considerably from country to country and from race to race. So in African and Asian women living in poor conditions the incidence and

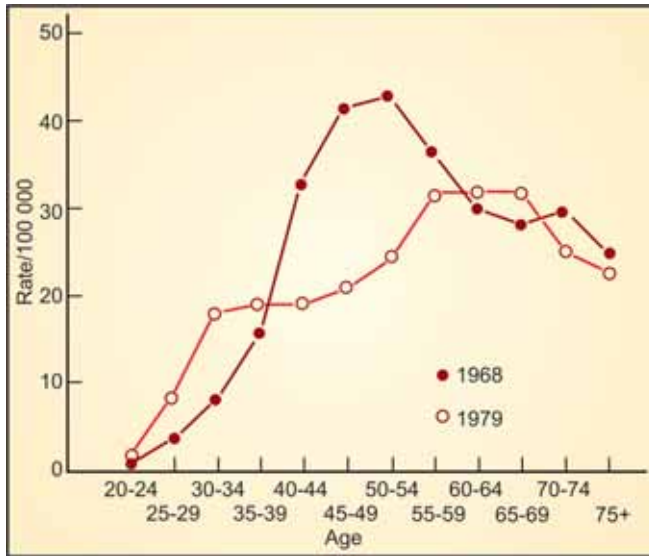
relative mortality rate of carcinoma of the cervix may be four or five times higher than those seen in developed countries. With the modern shifts in populations and migrations, the extent of the problem may fluctuate in the same area from time to time. It used to be said that for every case of carcinoma of the endometrium there are three or four of invasive carcinoma of the cervix. But in western communities this is no longer true and the ratio is approaching 1:1. One explanation of this is that more women are living to a later age which gives them more chance of developing carcinoma corporis. There is, nevertheless, much evidence to show that the incidence of carcinoma of the cervix has fallen in many countries in recent years (see page 508).

### Aetiology

What follows under this heading applies mainly to squamous cell carcinoma, intraepithelial and invasive. Little is known about the factors determining adenocarcinoma of the cervix.

#### Age

Although invasive cancer of the cervix is reported at all ages, even at birth, it now has two peaks, one at about 35 years and another at about 50-55 years, following which there is a reduced incidence (Fig. 29.5). Cervical



**Fig. 29.5:** The change in pattern of invasive carcinoma of the cervix in the United Kingdom as derived from published figures of the Office of Population Census and surveys for the years 1968 and 1979. There was a distinct change from a single peak to a double peak and also an increased rate in women under 40 years of age

intraepithelial neoplasia (CIN) occurs at a much lower age, one-third of the cases being found in women less than 30 years old.

### Race

The women of certain races, notably Orthodox Jewesses, are almost immune to cervical cancer. This was once thought to be explained by the fact that their husbands are subjected to ritual circumcision in childhood, to the observance of a high moral code, or to the strict avoidance of coitus during and after menstruation when the cervical epithelium might be more vulnerable. Similar findings have been seen in Muslims. In this community also, circumcision is the rule. That circumcision of her male partner can protect a woman from this disease is now very doubtful. Experience amongst other races where this operation is or is not routinely performed is quoted but the outcome is very conflicting. Since underprivileged Jewesses also rarely develop cancer of the cervix it must be concluded that genetic and racial factors can be strong determinants. This view is supported by the fact that the disease can show a familial incidence. Also there are certain races in which carcinoma of the cervix is unusually common,

Africans for example, and these are even more susceptible if they live in conditions of squalor.

### Social and Economic Factors

Excluding 'immune' races, the disease is more prevalent amongst women living in poor conditions, with a low income and indifferent education. Invasive carcinoma of the cervix is 20 times more common amongst the wives of unskilled labourers than it is in those of professional men. Detailed studies have revealed that certain occupations of men are associated with a higher incidence of cervical carcinoma. The possible operating factors are: low standards of cleanliness (including penile hygiene), coitus or marriage at an early age, frequency of sexual intercourse, and promiscuity of both partners. Men in jobs which require frequent travel and those whose first wives died of cancer cervix constitute a group termed as 'high-risk males'.

### Coitus

The sexually active woman is two to four times more likely to develop cancer of the cervix than is the sexually inactive woman. Cancer of the cervix is almost unknown in groups of nuns, whereas cancer of the corpus occurs as frequently in these as in any other section of the population. The disease is rare in all virgins although there are occasional exceptions (Fig. 15.26). Indeed, the practice of coitus is now established as being a prime cause of cervical malignant disease, intraepithelial or invasive. The earlier the age of first intercourse, the more the partners, and the more promiscuous the partners, the greater the risk. The incidence of positive cervical smears amongst girls and women attending special (STD, genitourinary medicine) clinics is two or three times higher than that for all women of similar age.

To account for the relationship of cervical cancer to sexual activity, it was once postulated that smegma lying beneath the prepuce of the male phallus is carcinogenic, and this concept was linked with the possible protection offered by circumcision and the increased danger due to poor hygiene. Yet smegma was never shown to be carcinogenic, and the male phallus exposed to it continually did not develop malignant disease. How then does sexual intercourse operate?

One explanation is that spermatozoa are themselves carcinogens in that they provide the cervical cells with large quantities of nucleic acids. Normally these cells are phagocytic to spermatozoa, especially when undergoing

metaplasia. It is therefore suggested that cancer does not arise in fully established epithelium but in 'replacement' epithelium. The columnar cells at the junctional or transformation zone are continually being replaced by squamous cells which are differentiated from reserve cells or from underlying stroma (Fig. 25.10). If, during this process, they are provided with additional nuclear material from the heads of absorbed spermatozoa, this acts as a mutagen causing chromosomal aberrations and atypical epithelial activity. The cervix of the adolescent is especially prone to such metaplasia and this would explain the special danger of coitus in youth.

It is said that a coitus-induced invasive cervical cancer is most likely to appear approximately 25 years after the commencement of sexual activity. Yet some cancers arise at an earlier age; these, it is suggested, may have a different aetiology and are not preceded by an intraepithelial lesion.

If direct contact of the male phallus or of spermatozoa with the cervix is the underlying cause of most cervical cancers, it is likely that this disease has been encouraged by the newer forms of contraception in young women. The older barrier methods, such as use of a condom or vaginal diaphragm, may have been protective in more than one or two senses. More effective contraceptive measures such as 'the pill' and intrauterine contraceptive devices, however, not only allow direct contact with the carcinogens but favour more frequent coitus and with more partners. Moreover, the oral contraceptives themselves may tend to make the cervical epithelium unstable (see below).

#### *Childbearing*

Ninety-five per cent of invasive cancers occur in multiparae; but 70-80 per cent of mature women are parous. Any association with the bearing of children, or the bearing of many children, is not accounted for by cervical injury or infection during labour but by the sexual intercourse which results in the pregnancies. High parity usually means frequent coitus during many years, starting at a young age, and is often associated with poor socioeconomic conditions.

#### *Cervical Irritation and Infection*

Cervical trauma, chronic cervicitis and ectopy are no longer considered as aetiological factors in CIN or invasive cancer. Yet there are links between this disease

and the presence of the herpes simplex virus (type 2) and human papillomavirus (HPV) in the vagina. The evidence derived from epidemiological, antigen and antibody studies as well as molecular hybridisation techniques demonstrates an association of these viruses with cervical carcinoma.

There is now ample evidence that the human papillomavirus plays a very important role in cervical carcinoma and is the causative factor in virtually all these cases. Low-risk and high-risk types have been identified (see page 421). Different strains are found in different regions. Fifteen to twenty types of HPV have been associated with cervical carcinoma; types 16, 18, 31 and 45 account for 80 per cent of cervical carcinoma; HPV 16 is associated with 50 per cent of cases.

The papillomaviruses are implicated probably in the same way as spermatozoa, by initiating changes in cervical cells during an unstable stage of their life cycle and therefore acting as mutagens or co-factors.

It has long been established clinically that the prolapsed cervix, although exposed to constant mechanical irritation, is remarkably free from the risk of cancer. This was formerly explained by supposing that its displacement removed it from the environment of a vagina made harmful by 'exudates'. Perhaps the papillomavirus should now be substituted for this term. Efforts are now ongoing to develop an HPV vaccine for the prevention of cervical carcinoma.

#### *Oestrogens*

While an excessive and unbalanced oestrogen stimulation favours the development of cancer of the cervix in certain lower animals, this is not established for women. Indeed the disease occurs commonly after ovarian activity has ceased — even after surgical removal of both ovaries.

Nevertheless, there is some evidence that oestrogen-progestogen oral contraceptives can favour CIN.

#### *Predisposing Histological States*

Certain histological changes in the cervix which have been alleged to be 'precancerous', or which are sometimes confused with cancer, include basal cell hyperplasia, squamous cell metaplasia and CIN. Of these, only CIN II-III are likely to be significant forerunners of invasive carcinoma (see Chapter 25).

## Types of Cancer; Pathology

### Histopathologic Types

- Cervical intraepithelial neoplasia, Grade III
- Squamous cell carcinoma *in situ*
- Squamous cell carcinoma
  - Keratinising
  - Non-Keratinising
  - Verrucous
- Adenocarcinoma *in situ*
- Adenocarcinoma *in situ*, endocervical type
- Endometrioid adenocarcinoma
- Clear cell adenocarcinoma
- Adenosquamous carcinoma
- Adenoid cystic carcinoma
- Small cell carcinoma
- Undifferentiated carcinoma

### Histopathologic Grades (G)

- GX — Grade cannot be assessed;
- G1 — Well differentiated;
- G2 — Moderately differentiated;
- G3 — Poorly or undifferentiated.

Cancer nearly always starts at the squamocolumnar epithelial junction and in 80-90 per cent of cases is squamous cell in type. In about 5-10 per cent of cases it is entirely columnar cell in pattern (adenocarcinoma) and the frequency is increasing, especially in younger women who are smokers or pill-users.

The predominance of squamous cell tumours in older women and the occurrence of mixed patterns is rather in keeping with the idea that most cancers arise in reserve cells.

### Adenocarcinoma

Both *in situ* and invasive forms of adenocarcinoma (and of mixed patterns) are described but, when diagnosed, this disease is nearly always invasive. Moreover, despite what is said above, it usually arises in the endocervix suggesting that its origin may be the columnar cells normally found there. It is usually ulcerative and infiltrative, leading to a hard, indurated, barrel-shaped cervix (Fig. 29.6). The histological appearances vary. The cells are essentially columnar in shape; they may contain mucin and form acini. Anaplasia is common and it is sometimes difficult to distinguish a columnar from an undifferentiated squamous cell cancer. However, if



Fig. 29.6: An endocervical adenocarcinoma which has spread to the corpus and also to the external os

mucin stains, electron microscopy and other methods are used, the correct diagnosis can usually be made or the tumour is classed as undifferentiated.

In some cases a cancer arising low in the corpus or in the isthmus is mistaken for, or is indistinguishable from, a primary cervical lesion.

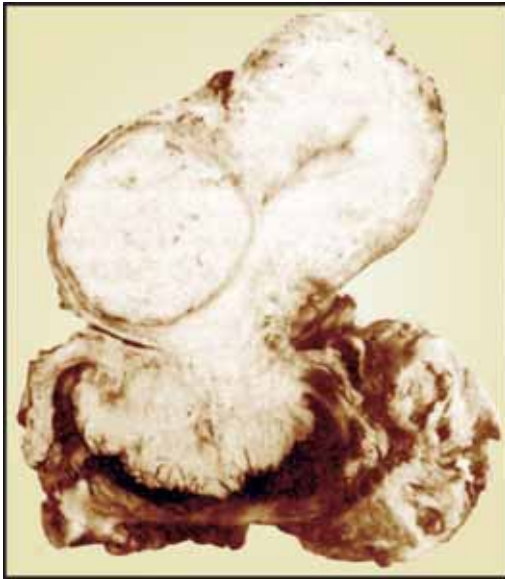
A few adenocarcinomas of the cervix arise from the wolffian duct and these are sometimes described as mesonephromas. Endometriotic carcinomas have the best and glassy cell carcinomas the worst prognosis among the variants of adenocarcinoma. Clear cell adenocarcinoma may be associated with exposure to diethylstilboestrol (DES).

### Squamous Cell Carcinoma

Squamous cell carcinoma usually starts in the area of the squamo-columnar junction (transformation zone) as described above. Occasionally, however, it arises in the endocervix, sometimes deep to the lining. Even if not all squamous cell growths begin in reserve cells, those developing in the endocervix almost certainly do.

Squamous cell carcinoma of the cervix is seen in the microinvasive and invasive forms. Some invasive cancers of the cervix are hypertrophic or exophytic, producing a cauliflower-like mass; others are mainly eroding and ulcerative or infiltrative (Figs 29.7 and 29.8). An early growth can simulate an erosion. The squamous cell carcinoma has histological features similar to those of an epithelioma in any site except that pearl formation is unusual.





**Fig. 29.7:** A hypertrophic squamous cell carcinoma of the cervix fungating into the vaginal vault. There is a leiomyoma in the uterus

About 20 per cent of the tumours are of the well-differentiated type (often known as ‘large cell keratinising tumours’). Moderately differentiated tumours (‘large cell non-keratinising tumours’) constitute about 60 per cent of the total. The remaining 20 per cent are poorly differentiated (‘small cell non-keratinising tumours’). However, biopsies taken from different areas of the same tumour often show different degrees of differentiation and different predominant cell types.

Two distinctive histological variants of cervical squamous cell carcinoma merit mention; some, usually of the well-differentiated type, have cells which contain abundant glycogen and thus appear as ‘clear’ cells, whilst occasionally the poorly differentiated tumours assume a spindle-shaped cell form and so resemble a sarcoma.

### Spread

#### *Direct Extension*

By this mechanism the growth spreads to the body of the uterus, the vaginal wall, the bladder, and the cellular tissues of the broad and uterosacral ligaments.

Direct invasion of the rectum is rare because the pouch of Douglas intervenes. In the broad ligament the growth surrounds and constricts the lower ends of the ureters but does not invade them. Similarly, when it reaches the pelvic wall and the sacral plexus, it causes



**Fig. 29.8:** An early eroding squamous cell carcinoma of the cervix

sciatic pain but the nerves and their sheaths are never demonstrably penetrated.

#### *Lymphatic Permeation and Embolism*

Spread by the lymphatics in the bases of the broad ligaments and in the uterosacral ligaments is an early feature, the nodes most commonly involved being the obturator, external iliac and those at the bifurcation of the common iliac vessels. Others are the internal iliac, common iliac, sacral and ultimately the para-aortic nodes.

#### *Bloodstream*

This route is much less frequently used but embolic metastases are occasionally seen in the ovary, brain, bones and lungs. The occurrence of distant metastases without simultaneous involvement of the lungs is explained by the transfer of cancer cells by the vertebral venous plexus (see Chapter 2).

### Symptoms

In its very early stage, invasive carcinoma of the cervix causes no symptoms and is only discovered accidentally or as a result of routine search (see below). Symptoms come with surface ulceration and consist only of irregular uterine bleeding or discharge or both, these being peri- or postmenopausal in half the cases. The first episode of bleeding commonly follows coitus, straining at stool, or any circumstance which exposes the cervix to trauma, and may be slight. Later the losses can be alarmingly

heavy. The discharge is at first creamy or white but subsequently resembles dirty brown water; it has a particularly offensive and characteristic odour. The odour is caused by an infection of necrotic tissue with saprophytes.

Any other symptoms usually occur so late that they are to be regarded as evidence of advanced (late-stage) cancer. They include frequency of micturition, dysuria, urinary incontinence, rectal pain, deep pelvic ache, low backache, sciatica, ureteric colic, oedema of the legs, loss of weight, anorexia and malaise. Liver metastases may present as right upper quadrant pain and fullness; lung metastases as haemoptysis and a persistent, racking cough.

A remarkable feature of carcinoma of the cervix is that most of those who suffer from it do not present early for treatment, and this despite propaganda and health education. This is partly explained by the fact that the irregular bleeding or discharge is dismissed as being insignificant. Even those women who report symptoms immediately do not necessarily have the consolation of knowing that their growth is amenable to treatment because the duration of symptoms is not proportional to the extent of the disease.

### Physical Signs

In the early stages the cervix may appear normal, eroded or chronically infected. Suggestive signs are hardness, irregularity and bleeding on examination; any cervix which bleeds when touched is suspect.

When the disease is established the patient's general state is usually good but the cervix may be enlarged, misshapen, ulcerated and excavated, completely destroyed or replaced by a hypertrophic mass. The cardinal signs are hardness, friability, fixation and bleeding on examination. Whenever cancer is suspected, vaginal examination should be gentle lest it precipitate the most violent haemorrhage. If this should happen, the vagina should be packed tight with gauze and the woman kept lying flat with the foot of the couch raised.

The diagnosis is difficult if the growth is entirely intracervical. The external os then looks normal but the cervix as a whole feels big, broad and barrel-shaped. Fixation occurs relatively early but bleeding on examination is not a prominent sign in such cases. In most cases a rectal examination is more useful in determining the extent of spread within the pelvis.

### Complications

- *Pyometra*—The cancer obstructs the cervical canal and is also a focus of infection; pyometra is therefore common.
- Vesicovaginal and vesico cervical fistulas
- *Rectovaginal fistula*—This is rare in untreated cases.
- Hydronephrosis and pyonephrosis caused by ureteric obstruction
- *Uraemia*—This is caused by renal failure due to a combination of infection and ureteric obstruction. The ultimate causes of death in their order of frequency and importance used to be: uraemia; cachexia associated with recurrent haemorrhage; infection and interference with nutrition; complications of treatment; and remote metastases in vital organs (rare). With improved radiotherapy, uraemia is less common in developed countries as the main cause of death.

### Cervical Screening

Data from many countries have shown that screening with cervical cytology reduces the incidence and mortality from cervical cancer.

#### Principles

1. The purpose of a cervical screening programme is to reduce the incidence and mortality of cervical cancer.
2. Cervical screening should be population based with wide coverage (aim for at least 80% coverage of the population).
3. Cervical cytology is the most used method of screening.

### Screening Guidelines

#### Age Group to be Screened

This depends on the particular age distribution of deaths from cervical cancer and may be "country specific". Deaths from cervical cancer are rare before age 25. Women can be discharged from the screening programme at the age of 65 if they have had two negative smears in the previous 10 years.

#### Frequency of Screening

There is higher incidence of women developing an interval cancer if the time from the previous smear is extended beyond 3 years.

### Management of Cervical Cytology Results

Recommendations for management after a cervical smear :

1. *Routine recall:* For a reportedly normal smear
2. *Repeat smear:*
  - i. If smear is inadequate, repeat in three months.
  - ii. For mild dyskaryosis or borderline nuclear changes, repeat in six-twelve months, depending on national protocol. The recommended repeat interval allows for possible resolution of changes. If the abnormality persists on repeat cytology, colposcopy is recommended.  
An alternative approach is to perform high risk HPV typing in patients with borderline cytology. Colposcopy should then be performed if high risk HPV types are found. If high risk HPV types are not found, cytology should be repeated in 12 months.
3. *Refer for colposcopy:* For moderate or severe dyskaryosis, query invasive disease or query glandular neoplasia.

### Diagnosis

#### Cervical Biopsy

The diagnosis can only be made for certain by microscopic examination of cervical tissue; biopsy is essential in every case where signs or symptoms raise the slightest suspicion, and this irrespective of whether cervical smears do or do not contain malignant cells. The site of biopsy is usually clear when the disease is clinically evident and in most cases a biopsy can be obtained without the necessity for an anaesthetic. Unless a cone biopsy is taken, curettage of the endocervix is also essential to exclude an endocervical tumour.

#### Cytodiagnosis

Although the findings on routine cytodiagnosis can be a means of stimulating the investigation which reveals an early symptomless invasive carcinoma, cytology is not a diagnostic method. Indeed, in 10-15 per cent of cases of clinically evident cancer of the cervix, smears remain persistently negative. This is because the actively malignant cells are deep seated or the exfoliated ones are degenerated and contaminated by inflammatory cells or blood.

### Colposcopy and Colpomicroscopy

These techniques can, in the hands of experts, reveal cancer which is not apparent to the naked eye. The diagnosis, however, still has to be confirmed by biopsy, so their chief value is to indicate the sites from which tissue can most profitably be taken for histological examination.

The diagnosis and prognosis of carcinoma of the cervix is not always easy, as the following cases show.

A married nulliparous woman, aged 35 years, complained of cyclical menorrhagia for 1 year without any irregular bleeding or discharge. Examination revealed a normal nulliparous cervix with a tumour above which had all the signs of a uterine leiomyoma the size of a 10-week pregnancy. She was opposed to having children and it was decided to carry out hysterectomy. At operation the mass proved to be in the supravaginal cervix and, as hysterectomy proceeded, it was clear that the dissection was being carried out through malignant tissue which was infiltrating the outer coat of the bladder. Examination of this specimen showed a squamous cell carcinoma arising in the substance of the cervix and nowhere nearer than 1 cm to the endocervix or to the portio vaginalis. The patient was subsequently treated with what now would be regarded as inadequate radiotherapy and, as expected, she was admitted 9 months later with bleeding and discharge from the growth which had then ulcerated through the vaginal vault. Her husband was informed that the situation was hopeless and a box of radium needles was packed into the vaginal vault for 48 hours with the object merely of controlling the bleeding and discharge during what remained of her life. Thirty years later this woman was alive and well and free from any sign of growth!

A multiparous woman aged 44 years, a chronic attender at hospitals, was seen on account of menorrhagia for which no gross abnormality could be found. A small cervical polyp was removed and curettage carried out; all tissues showed nothing remarkable on histological examination. The menorrhagia persisted and 4 months later curettage was repeated and a menopausal dose of radium was inserted into the uterus. Thereafter the patient continued with minor complaints and attended a general physician for recurrent anaemia. When she developed lower abdominal discomfort she was again seen by a

gynaecologist and no pelvic abnormality was noted. A smear taken from the cervix was negative then, and again 3 months later when for the first time she complained of slight vaginal discharge. A mass was then noted to the left of and behind the uterus, and laparotomy revealed this to be an inoperable squamous cell carcinoma of the cervix which had already reached the pelvic wall. Even then the cervix looked normal and the cervical canal was not invaded. Another 4 weeks passed before a doubtfully positive smear was obtained. It was 2½ years after the first investigation before the diagnosis was made—despite repeated examinations by three different gynaecologists and despite full observance of the standard practices.

These cases illustrate the most dangerous type of cancer of the cervix; one which commences deep in the cervical tissue and which spreads eccentrically without breaking the surface of the genital canal. Such growths presumably commence in a gland whose epithelium has undergone squamous cell metaplasia.

### Clinical Staging of Disease

#### Rules for Classification

*Clinical-diagnosis staging:* Staging of cervical cancer is based on clinical evaluation; therefore, careful clinical examination should be performed in all cases, preferably by an experienced examiner and under anaesthesia. The clinical staging must not be changed because of subsequent findings. When there is doubt as to which stage a particular cancer should be allocated, the earlier stage is mandatory. The following examinations are permitted: palpation, inspection, colposcopy, endocervical curettage, hysteroscopy, cystoscopy, proctoscopy, intravenous urography, and X-ray examination of the lungs and skeleton, suspected bladder or rectal involvement should be confirmed by biopsy and histologic evidence. Conisation or amputation of the cervix is regarded as a clinical examination. Invasive cancers so identified are to be included in the reports. Findings of optional examinations, e.g. laparoscopy, ultrasound, CT scan, MRI, and PET scan are of value for planning therapy but, because there are not generally available and the interpretation of results is variable, the findings of such studies should not be the basis for changing the clinical staging. Fine needle aspiration (FNA) of scan detected suspicious lymph nodes may be helpful in treatment planning.

*Post-surgical treatment –Pathologic staging:* In cases treated by surgical procedures, the pathologist's findings in the removed tissues can be the basis for extremely accurate statements on the extent of disease. The findings should not be allowed to change the clinical staging, but should be recorded in the manner described for the pathologic staging of disease. The TNM nomenclature is appropriate for this purpose. Infrequently it happens that hysterectomy is carried out in the presence of unsuspected extensive invasive cervical carcinoma. Such cases cannot be clinically staged or included in therapeutic statistics, but it is desirable that they be reported separately.

Staging is determined at the time of the primary diagnosis and cannot be altered, even at recurrence.

Only if the rules for clinical staging are strictly observed it is possible to compare results among clinics and by differing modes of therapy.

The FIGO staging (1995) has been devised to allow comparison of results of therapy from various centres (Table 29.1) (Fig. 29.9).

#### Regional Lymph Nodes (N)

- NX — Regional lymph nodes cannot be assessed.
- N0 — No regional lymph node metastasis.
- N1 — Regional lymph node metastasis.

#### Distant Metastasis (M)

- MX — Distant metastasis cannot be assessed
- M0 — No distant metastasis
- M1 — Distant metastasis.

### Prognosis

Irrespective of the type of treatment the prognosis depends on the following:

#### *The Extent of Growth at the Time of Treatment*

This is the single most important factor.

#### *Site*

An endocervical growth is potentially more dangerous than one which grows on the vaginal surface because it is diagnosed relatively late, and it spreads to the broad ligaments and to lymph nodes relatively early.

#### *Naked-eye Appearance*

The hypertrophic, florid, massive growth filling the upper vagina generally carries a bad prognosis - even if

Table 29.1: FIGO staging

FIGO stages		TNM categories
	Primary tumour cannot be assessed	TX
	No evidence of primary tumour	T0
0	Carcinoma <i>in situ</i> (preinvasive carcinoma)	Tis
I	Cervical carcinoma confined to uterus (extension to corpus should be disregarded)	T1
IA	Invasive carcinoma diagnosed only by microcopy. All macroscopically visible lesions - even with superficial invasion - are stage IB/T1b	T1a
IA1	Stromal invasion no greater than 3.0 mm in depth and 7.0 mm or less in horizontal spread	T1a1
IA2	Stromal invasion more than 3.0 mm and not more than 5.0 mm with a horizontal spread 7.0 mm or less	T1a2
IB	Clinically visible lesion confined to the cervix or microscopic lesion greater than IA2/T1	T1b
IB1	Clinically visible lesion 4.0 cm or less in greatest dimension	T1b1
IB2	Clinically visible lesion more than 4 cm in greatest dimension	T1b2
II	Tumour invades beyond the uterus but not to pelvic wall or to lower third of the vagina	T2
IIA	Without parametrial invasion	T2a
IIB	With parametrial invasion	T2b
III	Tumour extends to pelvic wall and/or involves lower third or vagina and/or causes hydronephrosis or non-functioning kidney	T3
IIIA	Tumour involves lower third of vagina no extension to pelvic wall	T3a
IIIB	Tumour extends to pelvic wall and/or cause hydronephrosis or non-functioning kidney	T3b
IVA	Tumour invades mucosa of bladder or rectum and/or extends beyond true pelvis	T4
IVB	Distant metastasis	M1

FIGO stage	UICC		
	T	N	M
0	Tis	N0	M0
IA1	T1a1	N0	M0
IA2	T1a2	N0	M0
IB1	T1a1	N0	M0
IB2	T1b2	N0	M0
IIA	T2a	N0	M0
IIB	T2b	N0	M0
IIIA	T3a	N0	M0
IIIB	T1	N1	M0
	T2	N1	M0
	T3a	N1	M0
	T3b	Any N	M0
IVA	T4	Any N	M0
IVB	Any T	Any N	M1

it does not appear to have spread much beyond the cervix.

*Histology*

An adenocarcinoma offers relatively unfavourable prospects, not because it is less radiosensitive than a squamous cell growth as was once believed. Groups of cases of adenocarcinoma certainly show a much inferior salvage rate but this is because they include cancers in young women and more cancers in an advanced stage. Since adenocarcinoma is usually endocervical in site, it is discovered and treated relatively late. If the results of treatment are properly controlled by matching cases by age of patient, stage of growth and other factors, there is no difference between those of the two cell types. The same applies to mixed adenosquamous growths in older women but not in women under 40 years of age.

Among the squamous cell growths, the well-differentiated are to be preferred because they grow slowly and metastasise late. It is sometimes suggested that they are more radiosensitive but the widely accepted view is that the anaplastic tumours have the advantage in this respect. The presence of lymph-vascular space invasion (LVSI) is associated with a poorer prognosis.

*Age*

The younger the patient the more likely is the growth to be poorly differentiated in type and the worse the outlook.

*Ureteric Obstruction*

If, at the outset of managing a case, pyelography reveals unilateral or bilateral ureteric obstruction, the ultimate outlook is poor.

**Treatment of Invasive Cancer**

Treatment is by radiotherapy, surgery or chemotherapy, or by combinations of these. It is now highly specialised, and the best results can only be obtained when there is good teamwork between gynaecologists, radiotherapists, physicists and others with a particular interest and experience. Moreover, these require complicated and expensive equipment as well as trained nursing and technical staff, so centralisation of the facilities in any one area becomes more and more desirable. This inevitably means the congregation of most patients into special units, an arrangement which, despite its many

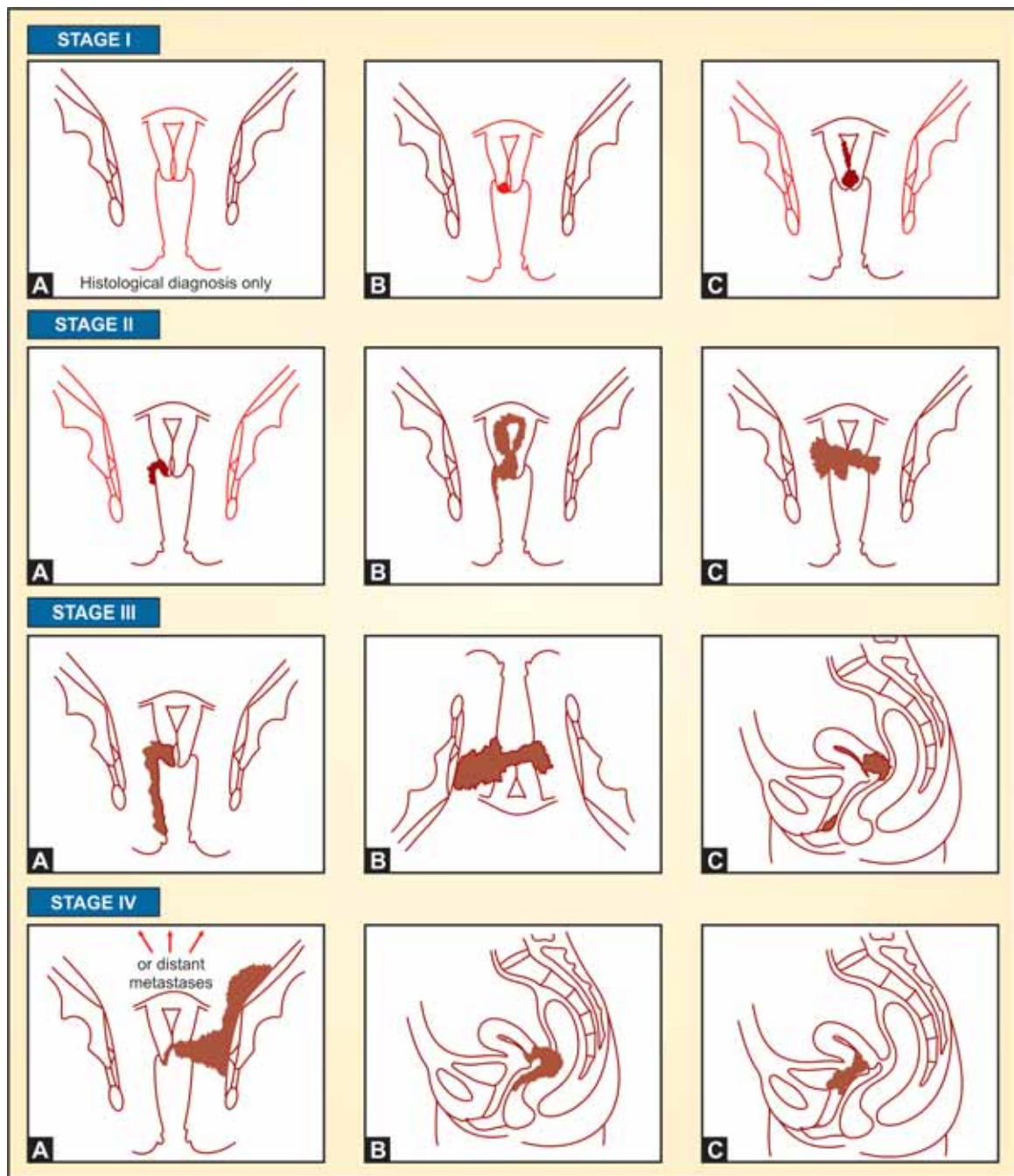


Fig. 29.9: The clinical staging of carcinoma of the cervix as agreed by the International Federation of Gynaecology and Obstetrics (FIGO). Carcinoma *in situ* (previously Stage 0) is excluded

disadvantages from the standpoint of patient happiness and radiation hazards, generally gives the best results in terms of patient survival.

The tendency to follow a fixed plan of treatment for all cases has an advantage when it comes to assessing

results. It is not, however, in the interests of the individual patient, and the aim should be to choose and to modify treatment to suit the circumstances of each case. It may even be necessary to change treatment if the initial response is not satisfactory. If it is concluded that

radiotherapy is not effective, it can be abandoned in favour of surgery. Unfortunately, the evidence suggests that poor responders to radiotherapy do equally badly with surgery. Table 29.2 shows management of advanced disease.

*Assessment of the Case Before Treatment*

Preliminary pelvic examination under anaesthesia may be necessary in order to estimate the extent of the disease, the size of the uterus and vaginal fornices, and to obtain material for histological study. Cystoscopy, intravenous pyelography and an estimation of the blood urea level are essential. The presence of remote metastases should be excluded as far as possible. Anaemia and malnutrition should be corrected, even at the expense of delaying treatment. A normal blood picture improves the results of radiotherapy considerably, possibly because it means better oxygenation of the malignant tissues; it is a prerequisite for safe surgery.

*Computed Tomography*

This can be used to demonstrate tumour spread. It can visualise enlarged lymph nodes (although it cannot

differentiate enlargement due to tumour from that caused by infection) and distortion of tissue spaces or planes by tumour or surgery. It is helpful for assessing recurrence of disease after surgical treatment of carcinoma of the cervix (Fig. 29.10). It provides more information about involvement outside the pelvis (see Chapter 1).

*Magnetic Resonance Imaging*

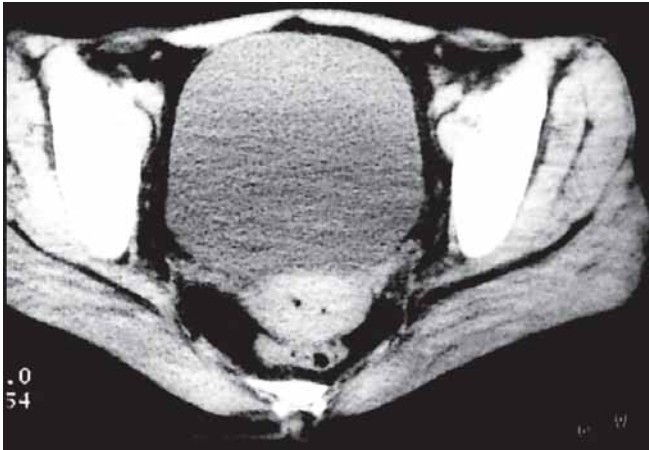
Magnetic resonance imaging is the best method of imaging to determine the size and extent of a tumour, especially if an endovaginal receiver is used. However, even with MRI, small metastatic deposits in the lymph nodes are likely to be missed.

*Radiotherapy*

This is the treatment of choice in the majority of cases and is applicable at all stages of the disease. It aims at giving a cancericidal dose of gamma-rays to all areas where there is growth or there is likely to be growth. The goal is to deliver a dose of 70-80 Gy at point A, this being situated 2 cm above the mucosa of the lateral vaginal fornices and 2 cm lateral to the central uterine

**Table 29.2: Management of advanced cervical cancer**

Stages	Stages IIB - IVA
Staging	Examination under general anaesthesia Chest X-ray Renal imaging Optional CT/MRI scan of abdomen and pelvis PET scan
<i>Radiation technique:</i>	<ul style="list-style-type: none"> <li>A. Primary target Tumour + uterus</li> <li>B. Secondary target Pelvic lymph nodes and common iliac lymph nodes. Field technique : 4 fields Field borders for external irradiation A. Tumour determined by palpation and CT Scan (if available) + 2 cm margin. B. A-P fields : Lateral : 2 cm lateral to the bony margin of the pelvic. Superior : Between L<sub>5</sub> and S<sub>1</sub> Inferior : 2 cm below the obturator foramen (or 2 cm below lower extent of clinical tumour)</li> <li>C. Lateral fields Anterior = individually determined by tumour. Posterior = individually determined by tumour.</li> </ul>
Primary target dose	: External irradiation 50 Gy/5-6 weeks + LDR intracavitary boost 30-35 Gy point A. (for IIB - IVA, 35-40 Gy)
Secondary target	: External irradiation 50 Gy/5 Weeks. Total treatment time : 6 - 7 Weeks
Concurrent chemotherapy	: Cisplatin 40 mg/m <sup>2</sup> every week during external irradiation



**Fig. 29.10:** CT scan displays a cervical mass posterior to the urinary bladder with air pockets within it suggestive of ulceration. (courtesy: Dr Shashi Paul)

canal. This objective is generally achieved by intracavitary therapy (see below). Point B lies 3 cm lateral to point A, i.e. the outer part of the broad ligament. This is exposed to 60 Gy by cobalt units or linear acceleration external beam radiotherapy. In certain cases, especially advanced ones, the last is used to cover the whole field. When combinations are used, the dose of one agent is adjusted to that of the other to ensure that the total dose is not excessive, using time-dose fractionation (TDF) and linear-quadratic (LQ) models. Despite all technical advances, however, intracavitary treatment centrally in the uterus and adjacent to the cervix in the vagina takes precedence over other forms of radiation. Intracavitary treatment is usually given at the end of the external therapy because it is more effective following reduction in tumour size.

Gamma-rays act by damaging the nuclear structures in actively dividing cells and by inducing a fibrous tissue and protective reaction in the host tissue. Radio-sensitivity depends to a large extent on whether the tumour receives a good blood supply from its bed. This may mean that a high oxygen concentration is the determining factor. In favourable cases the tumour disappears within 6 weeks. Overdosage not only causes adverse reactions and permanent ill-effects but is less likely to cure the carcinoma because it interferes with the host response. If the initial course of treatment offers a full cancericidal dose, radiotherapy can never be used again, even if the growth recurs.

Intracavitary (uterine and vaginal) therapy is very effective in cervical cancer because high doses can be

given centrally within the tolerance level of adjacent normal tissues.

## Techniques of Radiotherapy

### External Irradiation

External beam radiotherapy (EBRT) preferably from a linear accelerator using cobalt 60 is given in short daily treatments over a period of 3-6 weeks (usually on a Monday-to-Friday basis). This 'fractionation' of the total dose required is much more effective than a single total dose. The area covered by external beam therapy can be varied according to the stage of the disease but it should be arranged to cover the direct extension of the tumour and the anticipated area of lymphatic spread. In general, the area covered extends from just above the urethral orifice to the lower border of the fourth lumbar vertebra and laterally to cover the whole of the pelvis, with the femoral heads protected and related to the patient's physical characteristics.

### Intracavitary Radiotherapy (ICRT)

Since the first volume of this book was published there have been considerable changes in radiotherapeutic techniques. Radium has now been replaced by cheaper and more readily available artificially produced isotopes such as caesium and cobalt 60. The traditional method of treatment was to place radium in applicators in the uterus and vaginal fornices for a given period of time (27-30 hours), and then remove it and give a similar course of treatment either on three occasions at intervals of 3 weeks (Stockholm technique), or for 72 hours on two occasions, repeating the first course after an interval of 1 week (Manchester technique). The dose and duration of each treatment can be varied according to the size of the uterus and vagina in an individual patient but the time intervals between treatments remain constant for the chosen technique. To reduce the dose of radiation to the adjacent bladder and rectum, vaginal packing is used to increase the distance between them and the source of radiation.

The use of radioactive sources involves the exposure to radiation of medical and nursing staff while the sources are in theatre and while *in situ* in the patient, hence the development of afterloading techniques which are based on the traditional method described above but deliver much higher doses of radiation over a much shorter period of time (15-30 minutes compared with 24-48 hours). The more rigid applicators are inserted under



general anaesthesia and the source introduced later with the staff protected (Fig. 29.11).

Low-dose rate (LDR) therapy is the older system and requires fewer sessions but needs hospitalisation. High-dose rate (HDR) treatment can be done on an out-patient basis; it has less morbidity and is more cost-effective, though the equipment is more expensive.

Cathetron is the oldest cobalt 60-based HDR unit. Selectron was introduced as a LDR system but now an HDR system is also available.

Recently, heavy particle radiation using Californium-252 has been used which has a low oxygen enhancement ratio and can be used in bulky, poorly vascularised tumours containing a high proportion of hypoxic cells.

### Interstitial Brachytherapy

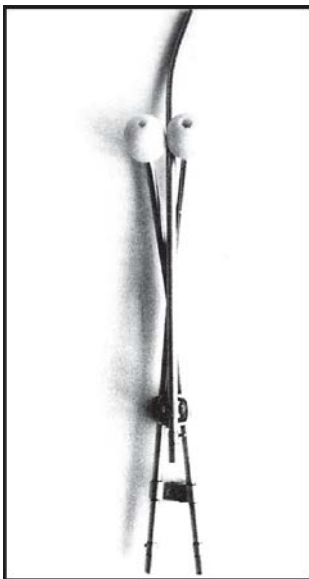
In patients with advanced parametrial disease, distorted anatomy or postoperative/postirradiation recurrences, the interstitial perineal implant (with or without the ICRT) can deliver supplementary dose following EBRT more optimally. Parametrial implants using radium needles were used earlier. Currently, afterloading transperineal perforated templates with iridium-192 and iodine-125 are used. (Figs 29.12 and 29.13).

The highest dose of radiation is given to tissues adjacent to the radioactive source and the dose then falls

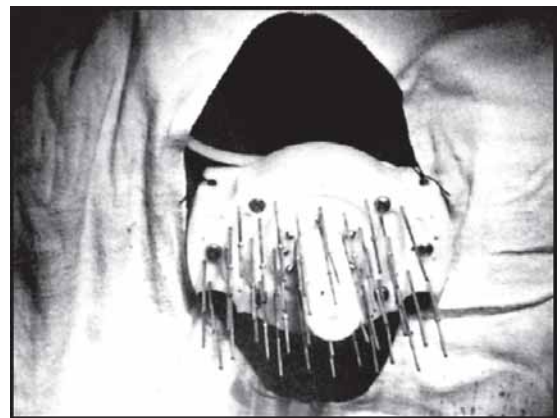
off rapidly, in an inverse fashion related to the distance. The fall-off in dose related to distance also explains why intracavitary treatment alone does not give a cancericidal dose to the lymph nodes on the pelvic side walls and why additional therapy is required for advanced lesions.

### Complications of Radiotherapy

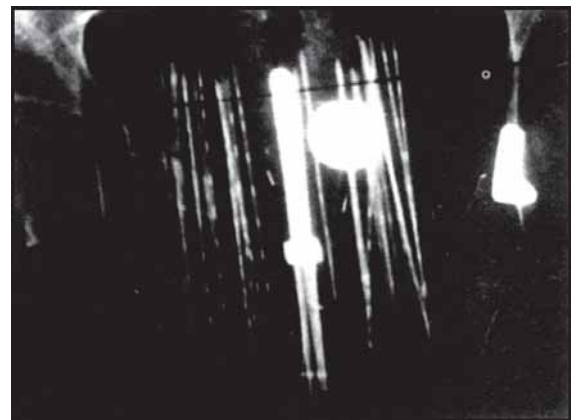
The morbidity resulting from properly conducted radiotherapy is minimal but major complications are sometimes caused by overdosage or technical errors. Perforation of the uterus may occur at the time of insertion of the uterine tandem, especially in patients with previous conisation or advanced disease. Pelvic inflammatory disease (PID), diverticulitis and previous surgery are associated with an increased morbidity. Since there is a fairly high incidence of PID in women with carcinoma of the cervix, a flare-up may occur during



**Fig. 29.11:** The afterloading Fletcher-Suit applicator for low-dose rate intracavitary brachytherapy (courtesy: Dr B.K. Mohanty)



**Fig. 29.12:** Syed-Neblett perineal template brachytherapy with iridium-192 source for advanced stage cancer of the cervix



**Fig. 29.13:** X-ray showing interstitial brachytherapy template with parametrial needles *in situ* (courtesy: Dr B.K. Mohanty)

radiotherapy usually 2-6 hours after insertion of the tandem; surgery may be required before any further irradiation, or is an alternative method of treatment. Indeed, sometimes it may be wiser to carry out a bilateral salpingectomy or salpingo-oophorectomy before radiotherapy. The small intestine (which has a much lower tolerance to radiation) is mobile, thus preventing too high a dose being given to any particular portion or loop of small bowel. The presence of adhesions prevents this and explains the development in some cases of the acknowledged late complications of intracavitary treatment.

#### *Morbidity during Treatment*

The majority of, if not all, patients will have some symptoms caused by the effects of ionizing radiation on the bowel mucosa. These are usually seen after a dose of 20-30 Gy has been administered. Diarrhoea, abdominal cramps, nausea, and occasionally bleeding from the bowel are the symptoms seen in these patients. A low-gluten, low-lactose, low-protein diet should be prescribed. The bowel symptoms usually settle down with appropriate treatment within a few weeks of completion of treatment but the majority of women will have some permanent minor change in bowel habit. Symptoms related to the bladder are uncommon unless there is a urinary infection. Occasionally, haematuria may occur.

#### *Late Effects*

These are related to the continued arteritis and fibrosis which is a consequence of radiation therapy. In the area treated, the small and large bowel are the most radiosensitive and late complications occur in 5-10 per cent of patients. Blood loss from the pelvic colon or rectum may be a problem with radiation proctitis, but it usually resolves with measures to keep faeces soft and the use of prednisolone suppositories or enemas. More serious complications are the fibrotic and vascular changes which lead to impaired function and narrowing of the bowel with subacute or acute obstruction. Some of these patients may require surgery. Occasionally, necrosis leads to perforation of the bowel and fistula formation. Once recurrent disease has been excluded, these can be managed surgically. The bladder is more resistant to radiation and, although there may be characteristic changes noted on cystoscopy, episodes of

haematuria which can occur are more often due to superimposed infection. The incidence of vesicovaginal and of rectovaginal fistulas following radiotherapy carried out in the best of centres is 1-2 per cent of each type, excluding cases due to recurrent tumour. Successful closure of these fistulas using flaps has been attempted. Vesicovaginal fistulas usually require urinary diversion. The risk of inducing tumours by modern radiotherapeutic techniques is low and at the most is almost one-and-a-half times the normal. The loss of ovarian function is associated with menopausal symptoms but except in young women it does not appear to cause many problems. There is narrowing and shortening of the vagina and this is aggravated by the associated loss of ovarian function and the general fixation of tissues following treatment. Coital difficulties are often underestimated, even though advice may be given initially regarding vaginal dilators and the resumption of coitus.

#### **Surgery**

Surgery can be carried out as a primary procedure, in Stages I and IIA, especially in young women to conserve ovarian function, or when carcinoma of the cervix shows a poor response to radiotherapy, or if it recurs after such treatment. For advanced and failed radiotherapy cases, ultraradical surgery such as exenteration is sometimes practised. Exenteration is more appropriate for patients with recurrent central disease occurring at least 2 years after radiotherapy.

In Stage IA1, where invasion is 3 mm, if there is no LVSI, conisation or an extrafascial total abdominal hysterectomy (Type I hysterectomy) may be sufficient. My policy is to try and individualise the treatment based on a proper assessment of all the factors. Conisation allows preservation of fertility in younger patients. If the lesion is within the limits defined above, surgical margins are free of disease and the patient desires a pregnancy, conservative management is possible, provided adequate and regular follow-up by cytology and colposcopy have been carried out. If there is any departure from the normal, or the family is complete, then Type I hysterectomy should be carried out. Even in Stage IA1, pelvic lymph node metastases are reported although the incidence is less than 1 per cent. If confluent areas or LVSI are present, or the disease is in Stage IA2, a Type II (modified radical) hysterectomy is recommended and pelvic node dissection is advisable.

This involves the removal of the whole uterus, the upper third of the vagina, the fallopian tubes and sometimes the ovaries, the broad ligaments together with their cellular tissue, the medial half of the cardinal and uterosacral ligaments and the pelvic nodes (Wertheim's original operation included selective removal of enlarged lymph nodes only). The uterine vessels are ligated medial to the ureter.

In Stages IB and IIA radical (Type III) hysterectomy as advocated by Meigs is recommended. This is a modification of Wertheim's hysterectomy. Complete pelvic lymph node dissection is done; the lymph nodes are removed starting from the common iliac and proceeding caudally to the groups around the internal and external iliac vessels up to the obturator fossa. Most of the uterosacral and cardinal ligaments are removed with the clamps being placed nearer the attachments of the ligaments to the sacrum after opening the rectovaginal space. The ureteric tunnels are dissected and the uterine vessels divided laterally. The more radical the resection of the parametrium, the higher is the incidence of postoperative bowel dysfunction.

The ovaries are involved in less than 1 per cent of patients with squamous cell carcinoma of the cervix, so they may be conserved in women younger than 40 years of age if they appear grossly normal. However, they should be transposed above the pelvic brim into the paracolic gutters and anchored there with a permanent suture, so that they can be spared the effect of radiotherapy should it be required subsequently (see below).

The discovery at laparotomy that the para-aortic lymph nodes are positive for cancer may prompt the operator to discontinue the operation and to opt for radiotherapy instead. Tumour extension into the bladder base which cannot be detected cystoscopically may prevent adequate mobilisation of the bladder flap, leading to the procedure being abandoned. For this reason, this part of the operation is undertaken early on opening the abdomen.

Okabayashi described his technique of radical hysterectomy in 1921. This technique aimed at improving the operability rate even in those patients with advanced disease, with a more radical dissection of the parametrial and paracervical tissue. Sakamoto and colleagues further modified this (Tokyo method). They attempted to preserve the base of the cardinal ligaments which contain the pelvic nerve bundles and also treated the ureters differently, leaving a protective sheath. Both these

technical differences resulted in a decreased incidence of bladder dysfunction which is the main advantage of the Tokyo method.

Several other modifications in the Wertheim's procedure have been reported from time to time; most of these have been attempts to decrease the rate of ureteric fistula formation.

A rather less extensive operation (so far as node dissection is concerned) can be carried out by the vaginal route (Schauta's or Schauta-Amreich's operation) but is only popular in a few centres. Mitra from India modified the operation and added bilateral extraperitoneal lymphadenectomy through two separate abdominal incisions to correct this deficiency. Nowadays, the Schauta's procedure can be combined with laparoscopic lymphadenectomy to decrease the morbidity of the procedure.

In selected young women with early Stage I disease confined to the ectocervix, who desire to preserve fertility, radical trachelectomy has been described recently, in which the cervix is removed along with the cardinal and uterosacral ligaments, and para-cervical tissue, followed by suturing of the uterus to the vagina. Lymphadenectomy is either done previously at a separate sitting or the lymph nodes are assessed by frozen section to be free of disease. The lymphadenectomy can be performed laparoscopically. Subsequent pregnancy has also been reported in almost half of these patients, but there is a risk of mid-trimester abortion or preterm delivery. This operation should not be performed unless the patient recognises the risk of recurrence of the disease.

#### *Indications*

Primary surgery is only applicable to Stage I and early Stage II cases, that is, to 30-40 per cent of all cases. For these, its place in preference to radiotherapy is largely a matter of personal opinion. Nevertheless, it may have advantages in certain cases, namely: when cervical cancer is associated with pregnancy, chronic salpingo-oophoritis, or other local disease of the pelvic organs; when narrowing or other anatomical errors of the vagina make it difficult to apply radium efficiently; possibly for endocervical tumours of the columnar celled type; and in the younger woman when it is decided that ovarian function should be conserved.

In favour of surgery, it is argued that it permits the removal of affected lymph nodes, which are invaded

with cancer in approximately 15 per cent of Stage I growths and which may not receive a cancericidal dose of radiotherapy. Moreover, some women are happier with the thought that the disease has been removed rather than 'treated'. Nevertheless, radical surgery is one which requires special skill and experience, and one which even the expert avoids when the cancer sufferer is obese, in poor general health, or has associated medical disorders.

### *Complications*

The primary mortality of radical surgery is 1-2 per cent, except in very skilled hands when it can be as low as 0.1-0.5 per cent. The immediate dangers are haemorrhage, shock, peritonitis, paralytic ileus, intestinal obstruction and thromboembolism. An average blood loss of 800 ml is reported.

The operation involves considerable risk of direct injury to the bladder, ureters and rectum. Ureteric fistula, previously a major complication, is now relatively uncommon as a result of improved operative technique especially in selected centres where experienced gynaecologists do these operations regularly.

Febrile morbidity is a common complication. Atony of the bladder, incomplete emptying, cystitis and pyelitis complicate 20 per cent of operations and there is generally a need for postoperative bladder drainage. Minor degrees of hydronephrosis and hydroureter occur in some cases but these changes usually disappear within 1 year. Nevertheless, ureteric incompetence, with reflux of urine from the bladder, persists in some cases and troublesome stress incontinence can be a problem. Late sequelae include stenosis of the ureter by surrounding fibrosis and lymphocyst formation. The latter, which occurs in 1-5 per cent of cases if lymphadenectomy is routinely carried out, can be mistaken for recurrent cancer; it is a cystic dilatation of the remaining but interrupted lymph channels and can be left untreated if small, aspirated under ultrasonic control or marsupialised into the abdominal cavity if large. Secondary infection requires drainage.

### *Combined Radiotherapy and Surgery*

Here we are concerned with combined therapy as a planned primary procedure, not with the resort to one when the other has failed or appears to be failing.

Radiotherapy may follow surgery and the usual indication for this is the unexpected discovery of an

occult invasive cancer in the cervix of a uterus removed by simple total hysterectomy alone or the finding of more extensive disease than expected, i.e. metastases to the pelvic lymph nodes, deep cervical invasion, invasion of paracervical tissue or positive surgical margins. Of these high-risk factors, only the last-mentioned is universally agreed on as being benefited by postoperative radiotherapy. In the case of positive pelvic nodes, radiotherapy has been shown to decrease the incidence of recurrence but there is no benefit in terms of survival unless there are at least three positive nodes. Stage IB2 disease has been shown to have a higher risk of metastatic disease and postoperative radiotherapy is recommended in these patients.

In young patients in whom invasive cervical cancer was found after simple hysterectomy, re-operation has been described. Pelvic node dissection, radical excision of parametrial tissue, cardinal ligaments and vaginal stump are done. Survival is reported to be similar to primary radical hysterectomy. However, as the anatomy is distorted after surgery, this procedure is technically more difficult and the usual practice is to give radiotherapy.

Sometimes, preoperative irradiation can make surgery possible when it would not have been otherwise. It is generally accepted that preoperative radiotherapy makes the surgery easier for the barrel-shaped endocervical carcinoma. There is considerable debate as to whether the dose of intracavitary treatment should be similar to that used normally or whether it should only be about one-half to two-thirds of the dose. Surgery is carried out within 10 days of radiotherapy, before reactions occur, or about 6 weeks later, when the immediate radiation reactions will have settled and the tumour regressed before the late changes in blood vessels occur.

The disadvantages of combined surgery and radiotherapy are as follows:

- The operation can be more difficult technically because of radiation reaction, if not carried out at the optimal time.
- Healing, especially of the vaginal vault, is delayed.
- Exposure of tissues to two risks increases the chance of fistula formation although this is not the experience of all those who adopt this method. These disadvantages are minimised by not giving more than two-thirds of the standard dose of radium, and by not dissecting the ureters too cleanly.

- If the surgeon fails to operate or cannot, for one reason or another, the patient's treatment is compromised because curative radiotherapy depends on a combination of the most appropriate dose and its timing.

Intraoperative radiotherapy (IORT) is now being tried in recurrent cervical cancer. The bowel is retracted out of the field and EBRT and ICRT administered.

### Chemotherapy

Chemotherapy has not been shown to cure cervical cancer but it can cause significant tumour regression. Single agents used are cisplatin, bleomycin, ifosfamide and methotrexate. The best response rates have been observed with cisplatin-based combinations. Neoadjuvant chemotherapy has been used in cases with bulky tumours preoperatively and in combination with radiotherapy. However, it has not been shown to improve survival rates. Concurrent chemotherapy and radiotherapy are now being tried with bulky and advanced cancer of the cervix. Preliminary results suggest that this may become the new standard of care in these patients.

### Ultraradical Surgery and Palliation

#### Results

Care is necessary in the appraisal of published results. Standards of diagnosis vary and a high cure rate may mean the inclusion of cases of carcinoma *in situ*, and of cervical conditions which not all would accept as malignant. The staging of growths is also inevitably a matter of opinion despite the guidelines laid down by FIGO.

There is, nevertheless, clear evidence that, in developed countries with good medical services, the overall results have improved considerably in the last 35 years. According to figures collected from many centres throughout the world, and covering treatments of all kinds - radiotherapy, surgery, and combinations of these - the 5-year apparent cure rate for women treated during the period 1941-1945 was 36.9 per cent. For the period 1976-1978 it was 55.0 per cent.

The change was due in large measure to earlier diagnosis and treatment, and to technical advances. In recent years the annual rate of improvement in results has slowed down considerably.

The results obtained anywhere depend mostly on the staging of the growth at the outset. The worldwide figures for treatments of all kinds indicate 5-year apparent cure rates as follows:

*Stage I:* 85 per cent of patients treated (Stage IB about 82 per cent: 87-91 per cent if node-negative and 51-67 per cent if node-positive)

*Stage II:* 60 per cent of patients treated

*Stage III:* 33 per cent of patients treated

*Stage IV:* 10 per cent of patients treated

In developing countries with poor medical services (often no facilities for radiotherapy of any kind), and where women rarely present for treatment before their cancers are in Stage III or IV, the overall results are still extremely depressing, relatively few cures being obtainable.

### Radiotherapy

The results vary with the circumstances and with the equipment available in any one centre. Given good, or exceptionally good (for these, take the figures at the tops of the ranges) facilities, the 5-year survival rates to be expected are 80-90 per cent for Stage I, 55-70 per cent for Stage II, 30-35 per cent for Stage III, 10 per cent for Stage IV, and an overall figure of 55-58 per cent.

### Surgery

It must be reckoned that only Stage I and certain selected Stage II cases are usually treated by radical hysterectomy. Given average to good surgical skill, the 5-year apparent cure rate is 70 per cent for Stage I, 45-50 per cent for Stage II, or 55-60 per cent for both stages combined. Nevertheless, there are a few gynaecologists throughout the world who, having specialised in this operation and acquired particular skill and experience, report 5-year survival rates of 85 per cent for Stage I, and 70 per cent for Stage II, cases. Amongst those patients whose lymph nodes prove positive for malignant cells, the 5-year apparent cure rate is as high as 30-35 per cent.

A 5-year survival rate of at least 50 per cent of patients treated is claimed for the *schauta* operation combined with extraperitoneal lymphadenectomy. Indeed, a few gynaecologists with experience of both operations say that the radical vaginal approach gives results equal to those of the radical abdominal operation and is attended by fewer complications such as fistula formation.

### Combined Radiotherapy and Radical Surgery

Reported experience suggests that a full or modified course of radiotherapy followed by radical surgery gives slightly better results than are generally obtained by surgery or radiotherapy alone. This is particularly true for Stage II cases, in which 5-year survival rates of 60-80 per cent are recorded, and in bulky disease. From the above it would appear that, for Stage I and certain Stage II cases, there is little to choose between the different methods of treatment as practised by experts. Nevertheless, assuming an average standard of skill on the part of the gynaecologist and radiotherapist, there is no doubt that treatment based primarily on radiotherapy offers the best chance in most cases of invasive cancer, early as well as advanced.

## RELAPSE

### Management of Patients who Relapse after Primary Treatment

Treatment decisions should be based on the performance status of the patient, the site of recurrence and/or metastases, the extent of metastatic disease and the prior treatment.

*Locally recurrent cervical cancer following:*

*Radical Surgery*

*Guidelines - Locally Recurrent Cervical Cancer Following Surgery:*

- Radiation therapy is indicated in patients with locally recurrent cervical cancer following radical surgery.
- Concurrent chemotherapy with either 5-Fluorouracil and/or Cisplatin with radiation should be considered and may improve outcome.
- Pelvic exenteration may be an alternative (particularly if a fistula is present) to radical radiotherapy and concurrent chemotherapy is selected patients without pelvic sidewall involvement.

### Therapeutic Options for Local Relapse after Primary Surgery

Relapse in the pelvis following primary surgery may be treated by either radical radiation or pelvic exenteration. Radical irradiation ( $\pm$  concurrent chemotherapy) may cure a substantial proportion of those with isolated pelvic failure after primary surgery.

Radiation dose and volume should be tailored to the extent of disease. Fifty Gray in 180 cGy fractions should be delivered to microscopic disease and using field reductions 64 to 66 Gy should be delivered to the gross tumour volume.

Where disease is metastatic or recurrent in the pelvic after failure of primary therapy and not curable, a trial of chemotherapy with palliative intent or symptomatic care is indicated. Cisplatin is the single most active agent for the treatment of cervical cancer.

The expected median time to progression or death is three to seven months.

*Local recurrence following definitive (radical) radiation:*

*Guideline - Local Recurrence Following Prior Radiotherapy.*

- Selected patients with small disease ( $\leq 2$  cm) confined to the cervix may be suitable for radical hysterectomy.
- Patients with a central recurrence and no evidence of metastatic disease should be considered for pelvic exenteration.

Radical hysterectomy may be used for patients with small disease ( $\leq 2$  cm) in diameter confined to the cervix. The morbidity is high, but some patients can be cured without need for a stoma.

Patients with a central recurrence that involves the bladder and/or rectum, without evidence of intraperitoneal or extra pelvic spread, and who have a tumour-free space along the pelvic sidewall, are potentially suitable for pelvic exenteration. The triad of unilateral leg oedema, sciatic pain and ureteral obstruction almost always indicates unresectable disease on the pelvic sidewall, and palliative measures are indicated.

The prognosis is better for patients with a disease-free interval greater than six months, a recurrence 3 cm or less in diameter, and no sidewall fixation. The five year survival for patients selected for treatment with pelvic exenteration is in the order of 30-60 per cent and the operative mortality should be  $< 10$  per cent.

### Further Observation

Whatever the method of treatment, the patient treated for invasive cancer of the cervix should thereafter be examined routinely every 3 months in the first 3 years, 6-monthly for the next 2 years, and yearly thereafter. At each visit, assessment of the situation is made by analysis of symptoms and physical signs, by cytology, renal

function tests and sometimes, with large central tumours, by endocervical curettage. A chest X-ray may be done annually in patients with advanced disease. Intravenous pyelography is indicated if a pelvic mass is detected or if there are urinary symptoms. CT scan may be done at 6-12 months in surgically treated patients with a high risk of recurrence to allow for early institution of radiotherapy. It is sometimes difficult to distinguish recurrence of cancer from later radiation reaction in the parametrium on cytology. As a general rule, however, it is wise to assume that any woman who, after a period of complete freedom after treatment, has a return of symptoms, or develops symptoms referable to the pelvic organs, has a return of growth. Most recurrences occur within the first two years after therapy.

Premenopausal patients may require counselling for sexual dysfunction and can be given hormone replacement therapy.

### Stump Carcinoma

The possible development of cancer in the cervical stump after subtotal hysterectomy is one of the reasons why this operation had virtually disappeared from gynaecological practice. Sometimes the malignancy represents a recurrence of carcinoma of the corpus (or even of the cervix) which was present at the time of operation and passed unrecognised. Otherwise the carcinoma (usually squamous cell) develops *de novo*, and is especially likely when the hysterectomy has been performed for pelvic infection.

The incidence naturally varies with the standards of gynaecology in any area. Where subtotal hysterectomy is carried out exceptionally, and then only after a negative cervical smear, stump carcinoma is rare.

The tumour behaves like any cancer of the cervix but carries a less favourable prognosis because the peritoneal cavity, the bladder and the rectum are all at the top of the stump. So they become invaded early, and do not allow the vital high intrauterine dose of radiotherapy. Radical surgery is more difficult and less complete in these cases because of the disturbed anatomy.

The 5-year survival rate for all cases of stump carcinoma after any method of treatment was formerly only 20-30 per cent, but the prospects have improved with modern radiotherapeutic apparatus and combinations of radiotherapy and radical surgery. Five-year survival rates of up to 60 per cent are obtained in the most advanced clinics.

### Carcinoma after Simple Hysterectomy

Often invasive carcinoma is found after hysterectomy for what was considered benign or preinvasive disease. If the original lesion was a small Stage IB tumour, a 5-year survival rate of 82 per cent may be achieved with radical parametrectomy, upper vaginectomy and pelvic lymphadenectomy. The other option with equivalent results is radiotherapy. A dose of 45 Gy is given over 5 weeks, followed by vault irradiation.

### Carcinoma of the Cervix Complicated by Other Pelvic Conditions

#### *Carcinoma of the Cervix and Pregnancy*

Cases of invasive cancer of the cervix discovered during pregnancy are usually Stage I or Stage II. The prognosis for those with advanced disease is relatively unfavourable because: the patient is relatively young; the hormonal and vascular changes in pregnancy encourage rapid growth and early dissemination; and the presence of the pregnancy hinders treatment.

Diagnosis is usually made by a colposcopy-directed biopsy if the Pap test is positive. However, if this is not possible a diagnostic conisation may be necessary and this should be done in the second trimester only if the Pap smear is strongly suggestive of invasive cancer, as the procedure carries a high risk of abortion.

Treatment depends on the stage of disease, the period of gestation, and the wishes of the patient. In Stage IA with no LVSI, patients may be delivered vaginally at term followed by hysterectomy 6 weeks later if no further childbearing is required or a conisation if further child bearing is required.

In Stage IA1 with LVSI and in Stage IA2, delivery is at term but by caesarean section and modified radical hysterectomy with pelvic node dissection is carried out at the same time. The tissue planes separate easily during pregnancy so dissection is facilitated, but there may be troublesome haemorrhage from engorged veins around the vagina.

In Stage IB, delivery can be delayed for a maximum of 4 weeks in the interests of improving foetal lung maturity. In tertiary care institutions, the foetus can be delivered after 32 weeks by classical caesarean section and radical hysterectomy with pelvic lymph node dissection.

In Stages II through IV, radiotherapy is the treatment of choice. In the first trimester, treatment is started with EBRT; spontaneous abortion may occur after the first sitting and usually results before the delivery of 40 Gy. In the second trimester, the patient's wishes and the available facilities need to be taken into consideration before deciding the timing.

In the third trimester, treatment is by classical caesarean section after foetal maturity is attained. This is followed by external irradiation and intracavitary therapy. The treatment is usually commenced 4-21 days after delivery of the child.

The overall 5-year survival rate is slightly better for patients with carcinoma cervix in pregnancy because they are usually in an early stage of the disease.

#### *Carcinoma of the Cervix Associated With Uterine Leiomyomas and Ovarian Cysts*

An ovarian cyst can be removed first, radiotherapy being given 2-4 weeks later. If large uterine leiomyomas interfere with adequate irradiation, a radical hysterectomy, or a combination of this with radiotherapy, is clearly indicated. In some cases it may be possible to carry

out radiotherapy in full, leaving the removal of the second tumour until later; the disadvantage is that the cyst or myoma may undergo necrosis.

#### *Carcinoma of the Cervix Associated With Salpingo-oophoritis*

Because of probable exacerbations with peritonitis and abscess formation, the presence of an inflammatory lesion in the adnexa, even a quiescent one, is a contraindication for radiotherapy. Radical surgery is preferable if it is technically possible. If it is not, it may be necessary to operate on the tubal disease first (bilateral salpingectomy or salpingo-oophorectomy) and to follow this by radiotherapy 4-6 weeks later.

#### **OTHER MALIGNANT TUMOURS OF THE CERVIX**

These include growths which have spread or metastasised from elsewhere, usually from the body of the uterus or from the vagina. Rare primary tumours include the melanoma. Sarcoma and mixed müllerian tumours are considered with similar tumours arising in the body of the uterus.



Enlargement of Uterus	487
Polyps	487
Benign Neoplasms	488
Malignant Neoplasms	503

### ENLARGEMENT OF UTERUS

The causes of enlargement of the body of the uterus are as follows:

- *Pregnancy or recent pregnancy*: This is the commonest and the first possible cause to be considered in the reproductive age group.
- *Retained products of conception*: Incomplete abortion and placental polyp. Delayed and incomplete involution.
- *Distension by fluid*: Haematometra; pyometra; hydrometra.
- *Hypertrophy (myohyperplasia)*: Developmental or idiopathic; active or passive congestion; excessive oestrogen, or oestrogen/progestogen stimulus.
- Adenomyosis
- *Cysts*: These, it is believed, arise from müllerian diverticula and are exceptionally rare.
- Endometrial polyp
- Benign neoplasms
  - Leiomyoma
  - Rarities such as the haemangioma, glioma, chondroma and osteoma
- Malignant neoplasms
  - Carcinoma
  - Sarcoma
  - Choriocarcinoma
  - Mixed mesodermal tumours
  - Metastatic growths from any site, including melanoma
  - Rarities such as the lymphoma and pericytoma.

### POLYPS

Many tumours of the uterus present as polyps within its cavity. For all practical purposes a uterine polyp comes under one of the following headings.

- Benign
  - Adenoma (mucous)
  - Leiomyoma (fibroid)
  - Placental (or foetal)

- Malignant
  - Carcinoma
  - Sarcoma; mixed müllerian tumours
  - Choriocarcinoma.

## BENIGN NEOPLASMS

### Adenoma

#### Pathology

A true adenoma occurs with or without associated endometrial hyperplasia and is invariably polypoidal (*mucous polyp*) (Figs 30.1 and 30.2). Polyps can be single or multiple; when the latter, the term *multiple polyposis* is sometimes used. The tumour rarely exceeds a grape in size and is usually no larger than a pea. On section it shows endometrial glands and stroma, and these may or may not react to ovarian hormones by exhibiting the menstrual phases.

Multiple polyps show a strong tendency to recur after removal. This is because they are generally a manifestation of endometrial hyperplasia with a persisting background of hyperoestrogenism. The cause of single mucous polyps is unknown.

#### Clinical Features

Single endometrial polyps are common, especially in the postmenopausal uterus when *they are mostly symptomless*;



Fig. 30.1: An endometrial polyp

they are often surprise findings on opening the excised organ. Symptoms are more likely when the tip of the polyp becomes necrotic and ulcerated; these include menorrhagia, intermenstrual (or postmenopausal) discharge, bleeding after coitus and, occasionally, uterine colic. The presence of a polyp may be suspected from the history and by finding the cervix patulous.

Transvaginal ultrasound reveals a thickened endometrial shadow. The endometrial polyp may be outlined at saline infusion sonography (Fig. 30.32b) or hystero-graphy. The diagnosis is made for certain by hysteroscopy or if the polyp is removed by curettage (*see* Fig. 30.7).

#### Treatment

Curettage can be done but this is not always satisfactory because one or more polyps may elude the polyp forceps. Hysteroscopy-guided polypectomy is the gold standard. Only very rarely will hyster-ectomy be required and then only if there is associated significant endometrial pathology.

### Leiomyoma (Myoma, Fibromyoma)

#### Pathology

Excluding pregnancy, the leiomyoma is the commonest of all pelvic tumours, being present in 20 per cent of women in the reproductive age group, and increasing with age. It is composed essentially of muscle tissue although there is a variable amount of fibrous connective tissue as well, especially in the older and larger tumours (Fig. 30.3). It is also termed *myoma* or *fibromyoma* and is popularly called a fibroid.

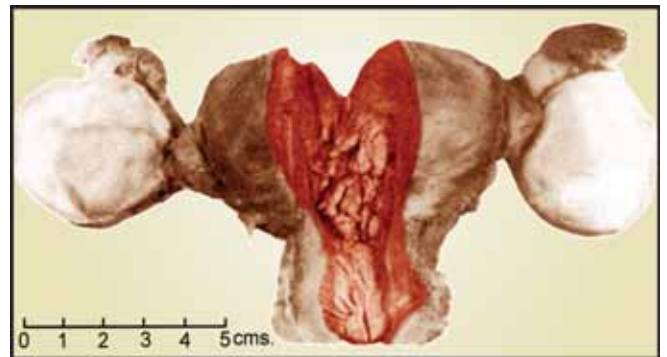
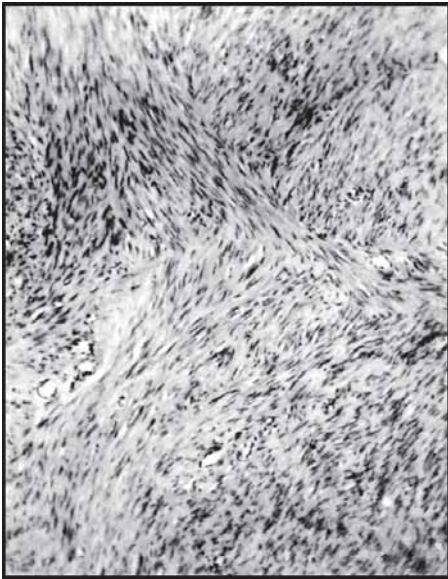


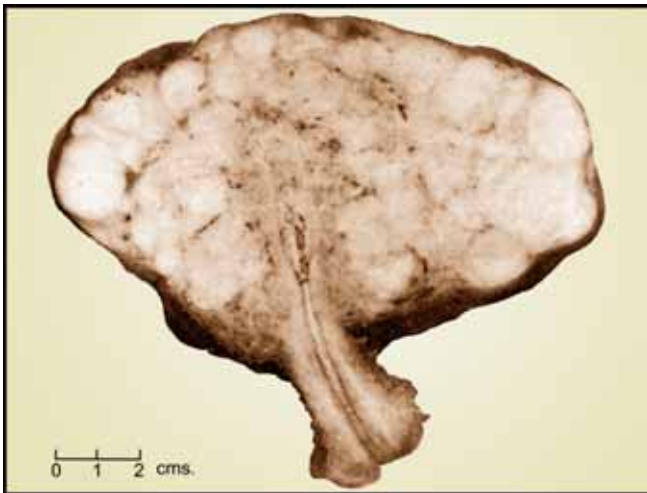
Fig. 30.2: Multiple endometrial polyps associated with endometrial hyperplasia and follicular cysts in the ovaries. The endometrial lesion could only be distinguished from carcinoma by histological examination



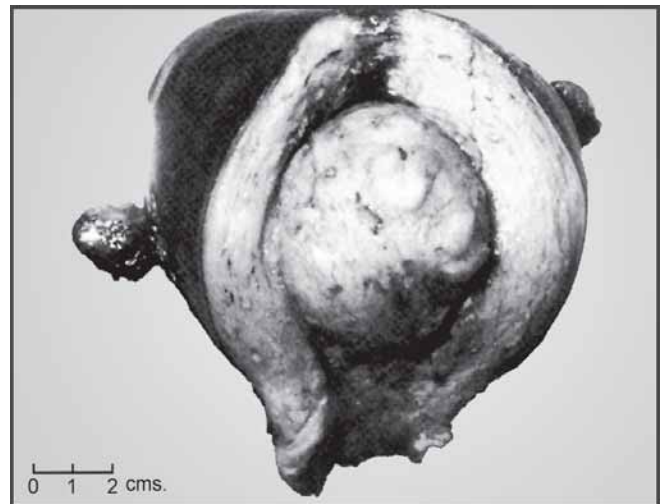
**Fig. 30.3:** Microphotograph of a leiomyoma of the uterus showing the interlacing bands of smooth muscle and fibrous tissue



**Fig. 30.5:** Symmetrical enlargement of the uterus caused by a single intramural leiomyoma. By becoming retroverted and impacted in the pelvis this uterus caused acute retention of urine in a woman aged 44 years



**Fig. 30.4:** Innumerable small leiomyomas scattered throughout the uterus of a nulliparous woman only 25 years of age. Such a distribution of tumours creates one of the few circumstances in which myomectomy is generally impracticable



**Fig. 30.6:** A single submucous leiomyoma in the uterus of a woman aged 56 years who complained of heavy but regular periods

Each individual uterine leiomyoma is monoclonal. It arises from a somatic mutation in a progenitor myocyte. Multiple chromosomal abnormalities are detected in approximately 50 per cent of leiomyomas by cytogenetic analysis; the commonest being translocation between the long arms of chromosomes 12 to 14 followed by deletion on the long arm of chromosome Y.

Leiomyomas are frequently multiple and as many as 200 maybe found in one uterus (Fig. 30.4). More often the number is between 5 and 30. The tumours tend to be spherical in shape although their surface can be lobulated (Figs 30.4 to 30.7). They are surrounded by a *pseudocapsule* which consists of compressed normal uterine wall. Except when modified by degeneration, they are hard



**Fig. 30.7:** A single subserous pedunculated leiomyoma diffusely calcified

in consistency and their cut surface presents a white and whorled appearance. They can grow to immense size filling the whole abdomen. There are accounts of a block and tackle having to be fitted to the theatre ceiling in order to lift the tumour from the abdomen at the time of operation. The modern development of ultrasound together with increased availability and safety of surgery have made mammoth tumours rare, but they are still to be found.

Leiomyomas are slow to grow and it is often said to take 3 years for one to reach the size of an orange. This, however, is only a generalisation; the rate of growth varies from patient to patient and from time to time in the same patient. There may be waves of growth interspersed with phases of quiescence, and a degenerative change can cause a rapid and gross enlargement of any tumour. An arrest or slowing of activity is most likely after the menopause but at least 10 per cent of leiomyomas continue to grow after this time.

The tumours themselves are relatively avascular, the main blood vessels being distributed in their capsules. Occasionally a tumour has numerous blood or lymph vessels, with large cavernous spaces throughout its substance; it is then called a *telangiectatic* or a *lymphangiectatic leiomyoma*.

## Aetiology

### Age

Uterine leiomyomas are rare before the age of 20 years but are to be found, if only as single tiny tumours, in approximately 20 per cent of women over 20 years of age and in 40 per cent of women over the age of 40 years. They most commonly cause symptoms between the ages of 35 and 45 years but probably exist in microscopic form before the age of 30 years.

### Parity

Leiomyomas are more common in nulliparous or relatively infertile women, but it is not known whether infertility causes leiomyomas or vice versa, or whether both conditions have a common cause. The general view is that the uterus which is deprived of pregnancies consoles itself with myomas or, as the old adage put it, 'fibroids are the reward of virtue, babies the fruit of sin'.

### Racial and Genetic Factors

The women of certain races, notably African, are especially prone to develop uterine leiomyomas. Also, irrespective of race, these can have a familial incidence.

### Ovarian Function

It is often suggested that excessive oestrogen stimulation causes leiomyomas but the evidence is unconvincing. These tumours do not significantly atrophy at the climacteric, as was suggested at one time. Moreover, they sometimes arise after the menopause - even after bilateral oophorectomy at an early age. However, oestrogen and progesterone may cause them to increase in size.

The original experiments, so frequently quoted in support of the idea that leiomyomas can be caused by oestrogens, are misleading in that the tumours which appeared in guinea-pigs after oestrogen therapy were neither true myomas nor situated in the uterus! To induce a 'fibroid' in an animal requires an incessant supply of hormone applied directly to the uterine wall.

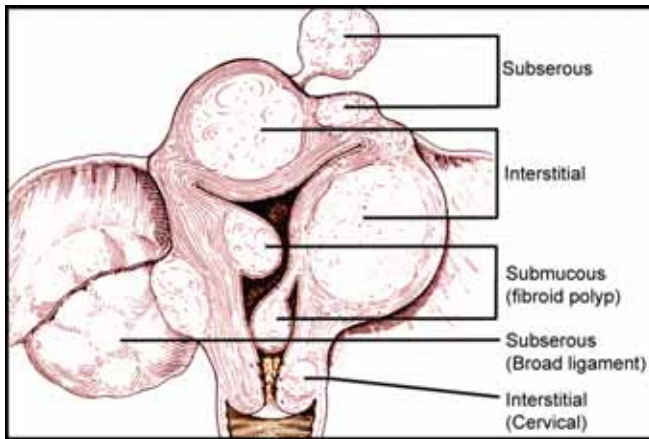
## Associated Conditions

Diseases commonly and possibly significantly associated with leiomyomas are follicular cysts of the ovary, endometrial hyperplasia, endometrial carcinoma and endometriosis. It is sometimes stated that salpingitis is a

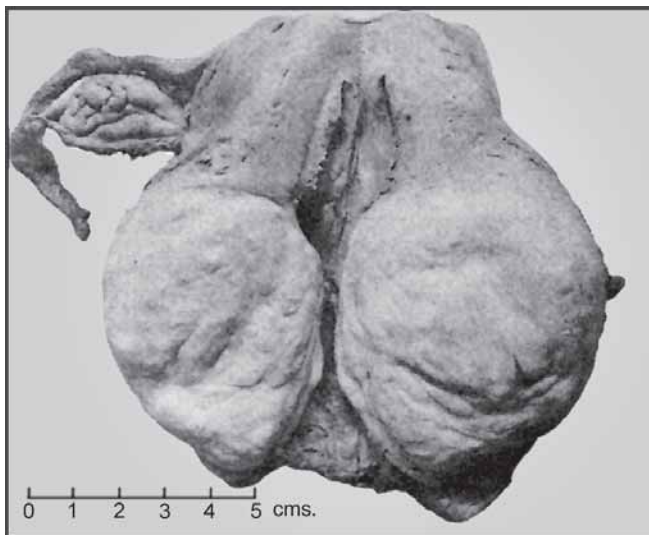
frequent finding but this is not true. The only possible link between the two is infertility. It may be added that when two conditions such as follicular cysts and leiomyomas have each a high incidence, their coexistence may be fortuitous.

**Sites**

Leiomyomas are described as being *subserous*, *interstitial* or *submucous*, according to their relationship to the peritoneal coat and to the endometrium (Fig. 30.8). Their site is determined by the position of their origin and by the direction in which they grow; an interstitial leiomyoma can, by development, become submucous or subperitoneal. Subserous and sub-mucous leiomyomas often become pedunculated.



**Fig. 30.8:** The sites of uterine leiomyomas



**Fig. 30.9:** An interstitial cervical leiomyoma

Most leiomyomas are situated in the body of the uterus but in 1 to 2 per cent of cases they are confined to the cervix and usually to its supravaginal portion. A *cervical leiomyoma* is commonly single and is either interstitial or subserous (Fig. 30.9). Rarely does it become submucous and polypoidal (Figs 30.10 and 30.11). The



**Fig. 30.10:** Small interstitial and submucous leiomyomas. One of the latter is being extruded through the cervix



**Fig. 30.11:** A submucous cervical leiomyoma extruded into the vagina. This site for a leiomyoma is most unusual. The tumour has been cut across to show its structure and its capsule. The probe is in the cervical canal

subserous tumour usually grows out into one or other broad ligament. The cervical leiomyoma presents special clinical features because, being extraperitoneal, it remains fixed in the pelvis and displaces the bladder and ureters; its removal is hazardous for the same reasons (Fig. 30.9).

A myoma developing in the cervical stump after subtotal hysterectomy is a rare but interesting possibility and can create a surgical problem (Fig. 30.12).

Extrauterine leiomyomas may develop in the broad ligament or at other sites where smooth muscle exists.

### Symptoms

The majority of small leiomyomas and some large ones are symptomless.

The nearer the leiomyoma to the endometrial cavity, the more likely it is to cause symptoms, especially menstrual symptoms.

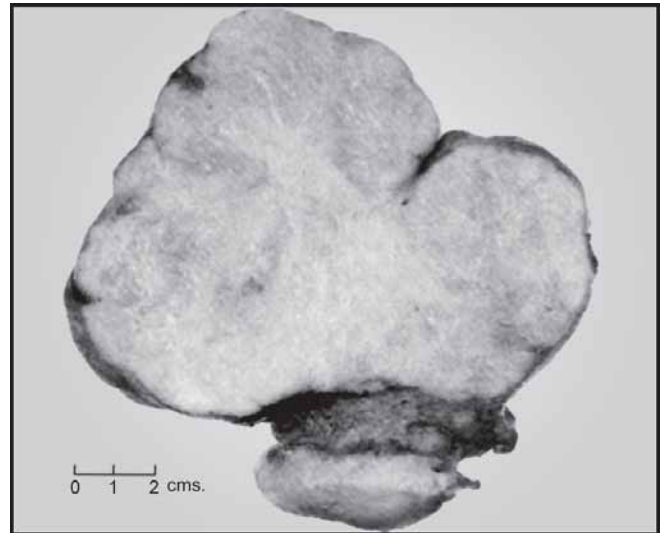
A leiomyoma does not cause pain unless it is complicated by: extrusion from the uterus as a polyp - in this case the pain is caused by uterine colic which 'aborts' the myoma; torsion of its pedicle or of the uterus; degeneration; sarcomatous change; or adhesions to other organs.

Pain which accompanies uterine leiomyomas is often caused by an associated lesion, especially endometriosis.

### General Effects

Manifestations of anaemia such as palpitation, lassitude, and even loss of weight, are common and can constitute the presenting symptoms; they result from menorrhagia.

A rare finding is polycythaemia which disappears when the leiomyoma is removed. In such cases the myoma is usually, if not always, large and situated in the broad ligament. The site may be important because polycythaemia is also known to complicate other types of broad ligament tumours. The explanations put forward to account for this phenomenon are: the tumour is itself erythropoietic — islands of extramedullary erythropoiesis have been documented in leiomyomas, a high level of erythropoietin activity has been reported within uterine leiomyomas; arteriovenous shunts have also been found in these tumours and these may also play a role; the tumour presses on the ureter and affects the erythropoietic function of the kidney. Polycythaemia increases the risk of thromboembolism, with or without surgery. Hysterectomy cures the polycythaemia.



**Fig. 30.12:** A myoma growing from the cervical stump after previous subtotal hysterectomy. The patient concerned underwent myomectomy carried out at the age of 30 years and, 2 years later, delivered her first and only child. During pregnancy new myomas were noted in the uterus and these were removed by repeated myomectomy one year later. The tumours recurred again so subtotal hysterectomy was performed when the woman was 37 years old. At the age of 46 years she was investigated for bleeding from the cervix but no abnormality was found. When she was aged 52 years, however, a complaint of fullness in the pelvis and bladder irritability led to the discovery of this tumour on the top of the cervical stump. At operation a second myoma was found in the remains of a round ligament and a third (?parasitic) in the omentum

Another extremely rare but interesting systemic effect of uterine leiomyomas is hypoglycaemia. This only occurs when the leiomyomas show unusual cellular activity and is more likely if they are retroperitoneal. Some pancreatic stimulus is postulated in explanation. Carbohydrate metabolism returns to normal after removal of the tumour. Hypokalaemia has also been reported.

### Menstrual Disturbances

The characteristic symptom of leiomyomas is *menorrhagia*, that is, an increased blood loss at normally spaced intervals, which is gradual in onset and progressive. The duration of the period may be normal or prolonged and the loss is heaviest on the second and third days when it sometimes justifies the description of 'flooding'. The cycle is not altered unless the tumours are so large as to disturb the blood supply and function

of the ovary. A woman with leiomyomas never has amenorrhoea, even of short duration, unless she is pregnant or past the menopause; indeed her menopause is likely to be unusually late.

The factors causing menorrhagia are: an increase in size of the endometrial cavity and of the bleeding surface; increased vascularity of the uterus; associated endometrial hyperplasia; hyperoestrogenism; compression of veins by the tumour(s) with consequent dilatation and engorgement of venous plexuses in the endometrium and myometrium; and interference with uterine contractions which are alleged to control the blood flow through the uterine wall (theoretical).

*Spasmodic dysmenorrhoea* is possible when a submucous tumour stimulates expulsive uterine contractions but is not common. Dysmenorrhoea of an unusual character, severe but one-sided, can be caused by a single but quite small leiomyoma which happens to be sited at the uterotubal junction from which uterine contraction waves arise. Congestive dysmenorrhoea may occur because of the associated pelvic congestion.

*Continuous and irregular bleeding and discharge* in association with leiomyomas is only seen in the following circumstances: surface ulceration of a submucous, and usually polypoid, tumour; sarcomatous change in a leiomyoma (rare); a coincidental pregnancy state; or a coincidental carcinoma of the uterus or endometrial polyp.

The association between endometrial cancer and leiomyomas is real but is not direct. The same type of patient is subject to both diseases. From the practical standpoint it means that every woman suffering from leiomyomas who has continuous or irregular bleeding should be subjected to endometrial aspiration before her treatment is planned. Indeed, this should be made a rule irrespective of symptoms.

### Pressure Symptoms

#### *Presence of Tumour*

A leiomyoma has usually to attain the size of a 14-week pregnancy or more, before a woman is conscious of swelling of the abdomen or of the presence of a hard tumour. Smaller ones can cause a sensation of weight in the pelvis.

#### *Alimentary Tract*

The mechanical effect of large tumours can be responsible for various forms of dyspepsia but

constipation from pressure on the rectum is exceptional, even when a leiomyoma is impacted in the pelvis.

#### *Bladder*

The weight of the tumour commonly causes bladder irritability with diurnal frequency. A cervical leiomyoma or a corporeal one which becomes impacted in the pouch of Douglas, causes retention of urine, but *not* by elongating the urethra as is generally assumed. The onset of retention is acute and usually occurs immediately before menstruation when the uterus is further enlarged by congestion, or during early pregnancy.

#### *Veins and Lymphatics*

Oedema and varicosities of the legs are sometimes seen with large tumours.

#### *Nerves*

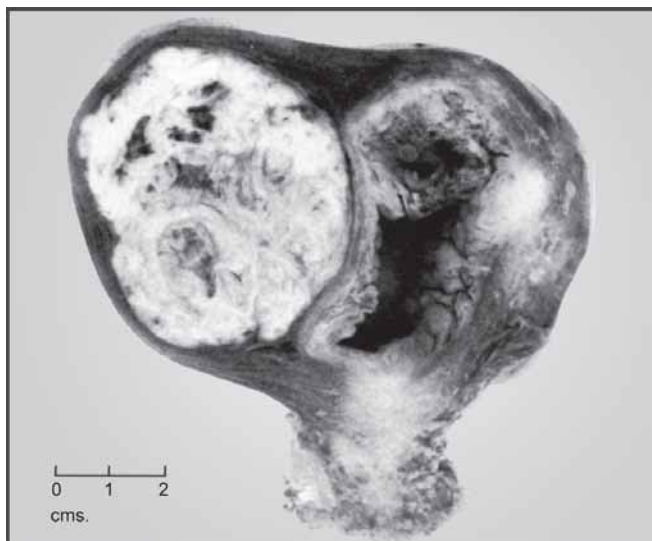
Pain from pressure on the nerves of the sacral plexus or on the obturator nerve is extremely rare, even when leiomyomas are impacted in the pelvis. Any pelvic tumour causing such pain is generally malignant.

### Symptoms Related to Pregnancy

#### *Infertility*

This can be either the cause or the effect of the leiomyoma. If the latter, it may be because the tumour interferes with implantation of the fertilised ovum, because it hinders the ascent of the spermatozoa by distorting the uterus and tubes, or because of an associated disturbance of ovulation. Those who believe that leiomyomas do lower fertility point out that 40 per cent of women with opportunity conceive after myomectomy. Those who take the opposite view point out that 30 to 50 per cent of all women attending an infertility clinic subsequently conceive, no matter what treatment is given. There is obviously a vicious circle; deferment of pregnancy encourages leiomyomas and the leiomyomas then discourage pregnancy. However, leiomyomas have been reported as a sole cause in less than 3 per cent cases of infertility.

Many women with leiomyomas succeed in becoming pregnant (Fig 30.13). Often the tumours are only discovered during routine antenatal examination. The pregnancy usually proceeds without serious compli-



**Fig. 30.13:** A pregnancy of approximately 4 weeks' development with a uterine leiomyoma. The leiomyoma shows areas of degeneration and a few extravasations of blood

cations, especially if the leiomyomas are not situated near the endometrium. Even very large subserous tumours do not usually disturb pregnancy.

#### *Abortion and Premature Labour*

These complications occur when the leiomyoma interferes with enlargement of the uterus, initiates abnormal uterine contractions, prevents efficient placentation, or causes impaction of the uterus in the pelvis.



**Fig. 30.14:** A pregnancy of 24 weeks' duration complicated by a large cervical leiomyoma. This subsequently obstructed labour and necessitated delivery by caesarean section. The lower abdominal tumour is the leiomyoma

#### *Malposition and Malpresentation of the Foetus*

These can result if the leiomyoma distorts the shape of the uterus or prevents engagement of the head.

#### *Obstructed Labour*

As pregnancy advances, most leiomyomas lift into the abdomen and do not complicate delivery. Labour can be obstructed, however, by cervical and broad ligament tumours which are fixed in the pelvis, and by pedunculated subserous leiomyomas which become trapped in the pouch of Douglas (Figs 30.14 and 30.15).

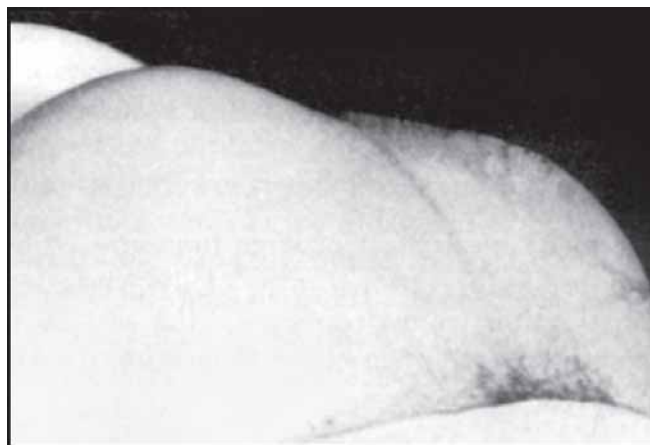
#### *Abnormal Uterine Action*

Inertia due to leiomyomas is only a theoretical possibility not supported by experience. These tumours do, however, predispose to third-stage difficulties and to postpartum haemorrhage especially if the placenta is implanted over the leiomyoma. They can also delay involution.

### The Effect of Pregnancy on Leiomyomas

#### *Increased Growth of Tumour*

Leiomyomas do not grow more rapidly during pregnancy. They invariably enlarge but this is because of congestion, oedema and degeneration and they usually return to their original size afterwards. Similar changes are sometimes seen during pseudopregnancy induced by oestrogen-progestogen preparations.



**Fig. 30.15:** A pregnancy of 32 weeks' duration is the cause of the right-sided abdominal tumour; the left-sided one is a large leiomyoma in the uterus. The patient in this case had a spontaneous vaginal delivery at term



*Degeneration*

Red degeneration is rather special to pregnancy but other types are more common. Degeneration of any kind is said to occur because the enlarging uterus puts tension on the capsule of the tumour and thus reduces its blood supply.

*Torsion*

Described elsewhere.

*Infection*

Described elsewhere.

**Physical Signs**

The tumour mass is usually, but not always, hard. It is rounded or lobulated and movable from side to side but not from above downwards. If palpable abdominally, the swelling arises from the pelvis and is nearly always dull to percussion because the intestines lie behind and beside it. 'Healthy' leiomyomas are not tender.

On bimanual examination, it is found that the tumour either replaces or is attached to the uterus. In a single and subserous leiomyoma with a long pedicle, the connection with the uterus may not be recognised. In such a case, distinction from an ovarian tumour is impossible. The diagnosis may be difficult if the

leiomyoma is soft and cystic as a result of degeneration. A submucous tumour produces symmetrical enlargement of the uterus but, if it is small, may be impossible to diagnose. Transvaginal sonography (TVS) aids in the diagnosis but may not detect some intrauterine tumours; these may be demonstrated by hystero-graphy, sonohystero-graphy, hysteroscopy or at hysterotomy (Figs 30.16, 30.32 and 30.7). Preoperative hysteroscopy helps in planning the management.

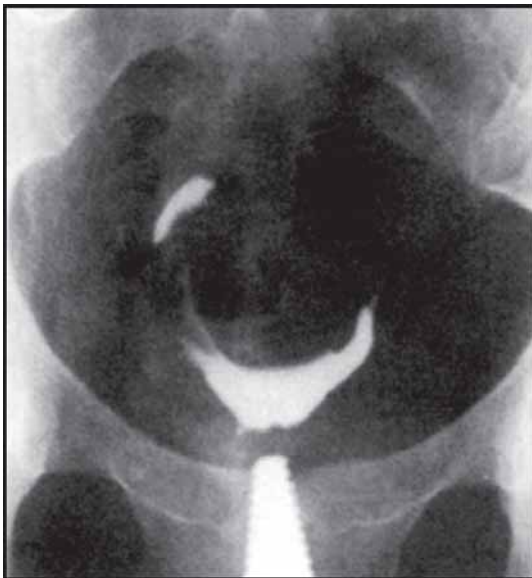
**Differential Diagnosis**

Leiomyomas have to be distinguished from all other causes of enlargement of the uterus and, so far as adenomyosis is concerned, this may be impossible. Differentiating points are described elsewhere.

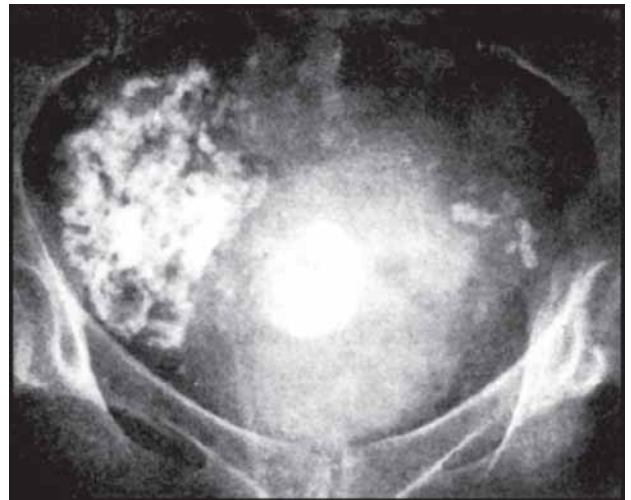
A soft leiomyoma is easily confused with pregnancy and errors in this respect occur even when the uterus can be visualised at laparotomy. Another common experience is to mistake one horn of a bicornuate uterus for a leiomyoma.

The means of distinguishing between a uterine and an ovarian, or other pelvic and abdominal tumours are described in Chapter 33.

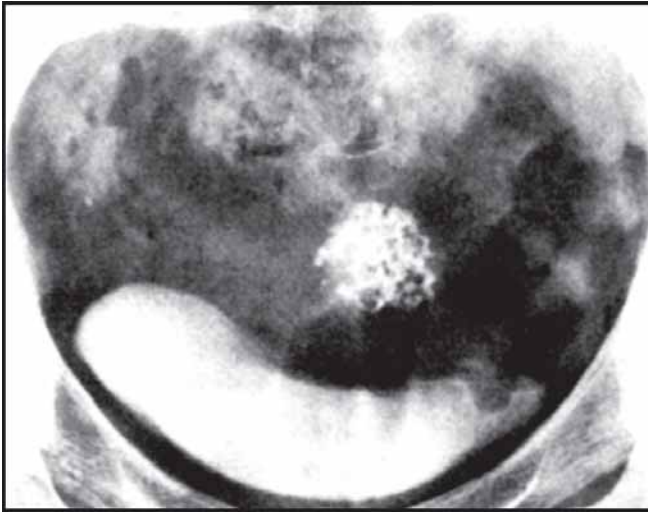
Occasionally, leiomyomas are first diagnosed by the finding of calcification in the tumour during radiological examination of the trunk for another purpose ('womb-stone') (Figs 30.17 to 30.19). This evidence is to be



**Fig. 30.16:** A hystero-gram showing a large filling defect caused by a submucous leiomyoma



**Fig. 30.17:** Calcified uterine leiomyomas. The one in the centre of the pelvis shows an 'egg shell' distribution of calcium and this means that its middle is wholly necrotic and avascular. The tumour on the right shows diffuse calcification and this implies that its centre still has enough circulation to permit transfer of the mineral



**Fig. 30.18:** Diffuse calcification in a small uterine leiomyoma, its position being orientated by instilling radio-opaque fluid into the bladder



**Fig. 30.19:** Early diffuse calcification in a large leiomyoma, the mineral 'streaming' along the lines of presumed vascular channels. (Radiograph presented by Mr C.H. Walsh)

accepted with caution, for myomas so diagnosed may prove to be: an ovarian tumour; a calcified tuberculous pyosalpinx; a calcified mucocele of the appendix; a retroperitoneal connective tissue tumour; or a tumour of the bony pelvis.

### Treatment

#### *No treatment*

Small symptomless leiomyomas discovered accidentally do not require treatment, although the patient should be kept under observation. It is only justifiable to operate on a symptomless tumour when it is larger than a 12-14-week pregnancy, if it is growing rapidly, if it is subserous and pedunculated and prone to torsion of its pedicle, if it is likely to complicate a future pregnancy, or if there is doubt about its nature. If the complaint is infertility alone, single or multiple tiny subserous leiomyomas are best left undisturbed; but intramural or submucous tumours, even of moderate size, deserve removal if no other cause is found.

#### *General Treatment*

Since the patient is usually anaemic it is important to investigate and to correct the anaemia before and after any operation is undertaken. This usually requires transfusion of packed cells. If the haemoglobin level is

below 4.5 g/dl, it is safer to transfuse packed cells slowly under cover of a diuretic.

#### *Palliative Treatment*

If for any good reason operation has to be postponed, menorrhagia can sometimes be *temporarily* controlled by administering danazol or norethisterone acetate. Alternatively, an oestrogen-progestogen preparation, such as is used for contraception purposes, can be given orally while awaiting surgery.

Danazol is often used before myomectomy to decrease the uterine blood flow.

GnRH agonists have the same effect and have been shown to decrease the volume of the uterus and the leiomyoma by 40-60 per cent. Thus they are used before myomectomy and have also been used to make vaginal hysterectomy, hysteroscopic resection or laparoscopic destruction more feasible. The administration of a single dose of leuprolide acetate depot 3.75 mg to anaemic women improves the haemoglobin level and also reduces intraoperative blood loss, thereby decreasing the incidence of blood transfusion. GnRH agonists are also used where there are medical contraindications to surgery, or where surgery is to be delayed for any reason.

In a woman approaching the age of the menopause, active treatment of symptom-producing leiomyomas is often delayed in the hope that cessation of ovarian

function would lead to control of the menorrhagia and eventually to atrophy of the tumours. GnRH agonists are useful in selected patients in this group. The administration of GnRH agonists is associated with menopausal symptoms and osteoporosis. Treatment is therefore limited to short-term use. Leiomyomas will recur in 50 per cent of women thus treated. Add-back therapy is helpful in minimising the hypo-oestrogenic effects.

### Curettage or Endometrial Aspiration

This never has a therapeutic effect on menorrhagia caused by leiomyomas. It is performed as a diagnostic procedure, to exclude an associated endometrial carcinoma, before myomectomy or hysterectomy. It is especially indicated when uterine bleeding is irregular or continuous.

### Polypectomy and Vaginal Myomectomy

Tumours presenting at or through the vaginal cervix are removed vaginally, taking care to exclude associated uterine inversion. Pedunculated intrauterine tumours can be removed hysteroscopically. Intra-cavitary tumours which are sessile or relatively inaccessible are preferably removed by abdominal hysterotomy. Their removal, whole or piecemeal through the cervix, can be a difficult and traumatic procedure.

### Abdominal Myomectomy

#### Indications

Abdominal myomectomy is the operation of choice in most patients less than 40 years of age, and in some older ones who treasure their menstrual and reproductive functions. Myomectomy is usually not ruled out by the size or number of the leiomyomas but it is unsatisfactory when there are innumerable tiny tumours scattered through the uterine wall (Fig. 30.4). More than 200 leiomyomas have been successfully removed from one uterus and it is relatively easy to enucleate 10-30 (Fig. 30.20). Distortion of the uterus is of no consequence: the shape is restored spontaneously within 3-4 months. The siting of a leiomyoma in the broad ligament amongst a network of large vessels can make for difficulty, and uncontrollable bleeding is always an indication for abandoning myomectomy in favour of hysterectomy.

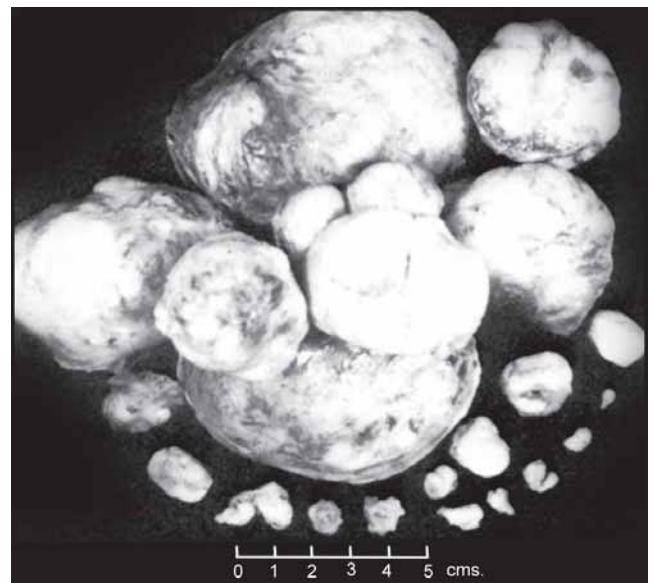
Because of the vascularity of the uterine wall, myomectomy is generally to be avoided during pregnancy and at the time of caesarean section. Nevertheless, pedunculated subserous tumours can safely be removed at these times. A painful mobile tumour found during pregnancy, which is thought to be a leiomyoma complicated by torsion or acute degeneration but which might be an ovarian tumour, often deserves laparotomy. However, unless it is reasonably certain that a leiomyoma is subserous, its treatment in pregnancy should be conservative. Similarly, at the time of caesarean section, the intramural fundal or cervical tumour is best left undisturbed. Myomectomy can be performed 3 months later, at which time the myoma is smaller and its bed less vascular.

Another argument against myomectomy during pregnancy is that it may precipitate abortion. The risk of this following the removal of subserous tumours is negligible.

#### Technique

Every myomectomy operation is different but should be planned according to the following principles:

- The patient must be warned previously that myomectomy may prove so difficult and dangerous that it may have to be abandoned in favour of hysterectomy. This is rarely necessary with experienced operators.



**Fig. 30.20:** A group of leiomyomas obtained by myomectomy from a woman aged 39 years who complained of infertility

- If infertility is the problem, the operation should be preceded by semen analysis on the partner. A finding of azoospermia may contraindicate myomectomy.
- If continuous or irregular bleeding and discharge is a symptom, preliminary curettage or aspiration is necessary to exclude an associated endometrial carcinoma.
- Even though the patient's general condition is good and the haemoglobin level more than 11 g/dl, cross-matched blood should be available for transfusion during operation.
- On opening the abdomen, the tubes and ovaries should first be examined to see that they are normal. The presence of bilateral tubal occlusion may change the decision in favour of hysterectomy unless *in vitro* fertilisation is a possibility.
- Bleeding from the uterine wall should be controlled by Bonney's clamp, or a rubber tube tourniquet, placed around the lower part of the uterus. Provided the metal blades are covered with pieces of rubber tubing, the clamp is both safe and useful. It usually offers a bloodless operating field and is always a means of lifting and fixing the uterus. Deliberate and meticulous surgery is thus facilitated. Neither the clamp nor the tourniquet can be used if a cervical leiomyoma is present, or not until it has been shelled out. The ovarian vessels can be controlled temporarily by sponge holders but this is not usually necessary.
- Incisions in the uterus should be as few as possible. Each should be so planned that as many leiomyomas as possible can be reached through it by burrowing in the uterine wall.
- Incisions in the anterior and posterior walls should be midline and vertical, in the least vascular area. Incisions on the peritoneal aspect of the posterior wall, however, involve risks of postoperative intestinal adhesions, and should be avoided as far as possible. Interstitial leiomyomas in the posterior wall can usually be approached via the anterior wall and uterine cavity.
- An interstitial tumour high on the posterior wall is sometimes best enucleated through a transverse fundal incision. The edge of the capsule is then brought forward and stitched low on the anterior wall to form a 'Bonney's hood'.
- In planning incisions, enucleating tumours and suturing cavities, it is important to avoid injury to, or occlusion of, the intramural portions of the tubes.
- The uterine cavity need not be opened if transvaginal sonohysterography and/or hysteroscopy have not shown the presence of any intrauterine polyps. If these facilities are not available, the cavity should nearly always be opened and a search made for intrauterine polyps - mucous or leiomyomatous. Omission of this step is only justified when the patient is not complaining of menorrhagia and the leiomyoma is obviously single and subserous.
- All tumour cavities should be carefully obliterated to avoid dead space and haematoma formation.
- Although some say it has the danger of producing ischaemic necrosis, I find it best to close large cavities with mattress sutures.
- Meticulous attention to haemostasis is important at all stages.
- The uterine serosal layer should be closed with a fine 3-0 suture, preferably using a modified baseball suture technique which will leave minimal amount of suture material on the surface and thereby lead to minimal adhesion formation.
- Myomectomy should nearly always be followed by some sort of round ligament shortening operation. Reduction of the size of the uterus means that these ligaments are slack, and retroversion may occur while they are involuting. Retroversion, especially in the presence of some oozing into the pouch of Douglas, favours postoperative adhesions — to the ovaries as well as to the uterus.

### Results

Myomectomy is said to be more dangerous than hysterectomy but this is not true for present-day surgery. The immediate mortality should not be higher than 0.2 per cent. Low-grade postoperative pyrexia is the rule and should not be treated by antibiotics. It is indicative of slight extravasation of blood into the uterine wall or peritoneal cavity and settles spontaneously in 7-14 days. Late sequelae, especially if the incisions are multiple and badly closed, are omental and intestinal adhesions to the uterus.

A disadvantage of myomectomy is that menorrhagia persists after operation in 1-5 per cent of cases. This is either because the myomas were not responsible for the original complaint, or because an intrauterine polyp or leiomyoma was overlooked at operation. The recurrence rate of leiomyomas after myomectomy is 5 to 10 per cent. The reappearance of tumours within 5 years probably

means that tiny seedlings were not recognised and removed during the original operation. Most recurrences occur after myomectomy in *young* women, those less than 35 years of age.

For one reason or another, 20 to 25 per cent of women subjected to myomectomy ultimately come to hysterectomy. This, however, is not a serious objection because in the meantime they have enjoyed continued menstrual and reproductive functions and many have had much-wanted children.

#### *Pregnancy After Myomectomy*

Of all women subjected to myomectomy, 25 to 30 per cent subsequently become pregnant. The figure is 40 per cent for those with opportunity to conceive.

#### *Effects on Pregnancy*

- *No effect:* This is the rule.
- *Abortion and premature labour:* These complications, *alleged* to be the result of scars in the uterus, are not, in my experience, more common than expected. But there are reports of an abortion rate as high as 25 per cent and of an increased perinatal mortality rate.
- *Rupture of the scar:* The scar of myomectomy hardly ever ruptures, either in pregnancy or labour, no matter how long the incision may have been and irrespective of its encroachment on the cavity. A few cases of uterine rupture are recorded but most gynaecologists with a wide experience of myomectomy have never seen such an accident.

*Treatment:* Delivery should be in a fully equipped hospital. Vaginal delivery should be the aim but, since the patient is likely to be advancing in years with a previous history of infertility, caesarean section may be indicated in the interests of the foetus if labour is not proceeding smoothly.

#### Laparoscopic Myomectomy

Laparoscopic myomectomy is possible but not widely practised as it is technically more difficult. It is best indicated for pedunculated subserosal myomas which are symptomatic because of torsion. Intramural leiomyomas have also been removed by enucleation and morcellation but the procedure is very time-consuming.

#### Myoma Coagulation (Myolysis)

Laparoscopic myoma coagulation uses lasers or the bipolar needle to drill holes into the substance of a subserous or intramural myoma. The myometrial stroma necroses, vascularity decreases and substantial shrinkage of the myoma results. If the patient continues to have heavy bleeding, the procedure may be combined with endometrial ablation to reduce the incidence of subsequent hysterectomy.

#### Embolotherapy

Uterine artery embolotherapy using polyvinyl alcohol or gel foam pellets has been tried in selected patients who are not fit for or desirous of surgical therapy although they have symptomatic uterine leiomyomas. Success rates of 96 to 98 per cent have been reported by experienced angiographers. Rarely patients may develop complete amenorrhoea. There is limited experience of pregnancy following this therapy but it is possible that these patients may have a lowered fertility with risk of placental insufficiency and uterine rupture in subsequent pregnancies because of interference with the blood supply and embolotherapy-induced necrosis of the leiomyoma.

#### Hysterectomy

This is the best treatment for uterine leiomyomas in women over the age of 40 years and in those who are not anxious for more children. The cervix as well as the corpus should be removed in most cases but the ovaries, if normal, should be conserved in premenopausal women. The operation can be carried out vaginally when the myomas are small but this route is not to be advocated when the uterus is larger than that of a 12-week pregnancy even though its bulk can be reduced.

The older woman with multiple leiomyomas who has been nursed through pregnancy is best treated by caesarean hysterectomy at term.

#### Complications of Leiomyomas

##### Torsion

Torsion of the pedicle of a subserous pedunculated leiomyoma interrupts first the venous and then the arterial supply, leading first to extravasation of blood

and then to gangrene. The accident usually causes acute symptoms calling for an emergency operation; its causes and clinical features are described elsewhere.

In certain cases of torsion in which the diagnosis is overlooked, or when the twist is intermittent, the tumour degenerates; its roughened surface then forms adhesions to the omentum and other structures. It obtains an additional blood supply through these and occasionally this becomes the only blood supply, the original connection with the uterus being severed. So a *parasitic leiomyoma* is formed which can be found anywhere in the abdomen but most often attached to the omentum (Figs 30.12 and 30.25).

### Haemorrhage

The rupture of a large vein on the surface of a leiomyoma is an uncommon accident resulting in the clinical picture of intraperitoneal haemorrhage and requiring urgent treatment. Haemorrhage into the substance of a tumour is unusual except in association with torsion of the pedicle.

### Ascites; pseudo-Meigs' syndrome

Very mobile tumours, usually pedunculated subserous ones, can cause ascites, presumably by mechanical irritation of the peritoneum. Rarely, the ascites is accompanied by a right-sided hydrothorax to produce a pseudo-Meigs' syndrome.

### Infection

A submucous leiomyoma nearly always becomes ulcerated and infected at its lower pole. Infection of myomas in other sites is generally preceded by necrosis. It only occurs following abortion or labour, when the tumour is adherent to the bowel, or when it becomes involved in appendicitis, diverticulitis and the like.

### Malignant Change

Sarcomatous change is found in only 0.2 per cent of tumours coming to operation but is a risk which cannot be discounted. The malignant process usually begins towards the centre of the tumour and the diagnosis is only made by histological examination of a removed myoma (Fig. 30.21). Sarcomas with a malignant behaviour have 10 or more mitoses per high power field (hpf).

There is another group of tumours known as 'Smooth muscle Tumours of Uncertain Malignant Potential' (STUMP tumours) which have 5-9 mitoses/10 hpf that do not demonstrate nuclear atypia or giant cells; or 2-4 mitoses/10 hpf with nuclear atypia or giant cells. Their significance is unclear and patients with such tumours need to be kept on long-term follow-up.

The development of sarcoma may be suspected clinically when a leiomyoma, usually in a postmenopausal woman, becomes painful and tender and grows rapidly, producing systemic upset and pyrexia.

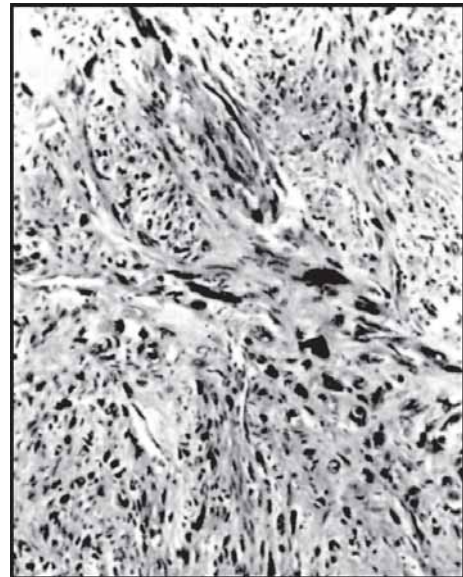
The overall 5-year survival rate for patients with this tumour is only 20 to 30 per cent.

### Degeneration

All leiomyomas which attain or exceed the size of an orange, and many which are smaller, show some form of degenerative change. The immediate cause of degeneration is an interference with the capsular circulation and, while the process is active, the tumour becomes painful, tender, softened and enlarged.

### Atrophy

Alleged postmenopausal atrophy is insignificant and unimportant.



**Fig. 30.21:** This shows bizarre changes in a leiomyoma which may be confused histologically with sarcoma by the inexperienced histopathologist

*Oedema*

Oedema may be only microscopic but is sometimes obvious to the naked eye. The fluid collects between tumour cells to form pools and 'cysts'.

*Hyaline Degeneration*

This, the commonest degeneration, first affects fibrous tissue cells which are replaced by a homogeneous substance which stains pink with eosin (Fig 30.22). The muscle fibres and bundles then become isolated and die, so that large areas of the tumour become structureless. Ultimately the hyaline material liquefies, leaving ragged cavities filled with colourless or bloodstained fluid (Fig. 30.23).

*Cystic Degeneration*

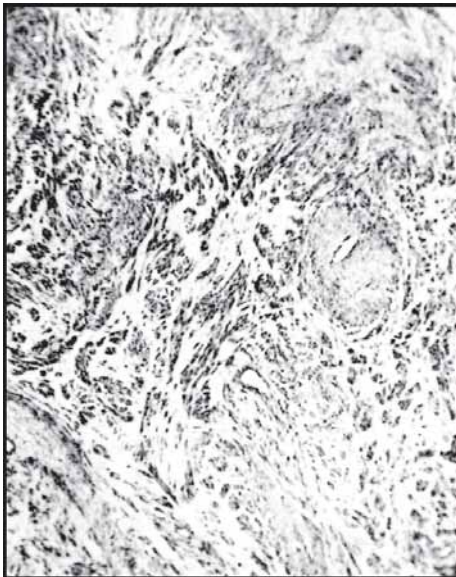
This is the end result of either oedema or hyaline degeneration (Fig. 30.24).

*Myxomatous Degeneration*

This is rare.

*Fatty Degeneration; Calcification*

Sometimes, and usually in association with partial necrosis, a leiomyoma contains fat. A later stage in this



**Fig. 30.22:** Early hyaline degeneration in a leiomyoma. It is the fibrous tissue elements which undergo hyaline change leaving islands of muscle tissue. Their isolation means that they ultimately die

process is the deposition of calcium, first in the form of calcium soaps. The calcium may be diffused throughout the tumour, a change which ultimately produces a 'wombstone' (Fig. 30.25), or it may have a peripheral



**Fig. 30.23:** A uterus containing a single subserous leiomyoma which, on section, shows one large and several small ragged cavities which are the result of hyaline degeneration followed by liquefaction of the necrotic tissues



**Fig. 30.24:** A large intramural leiomyoma showing diffuse cystic degeneration secondary to hyaline degeneration. The length of the uterine cavity after fixation is 30 cm



**Fig. 30.25:** A 'wombstone', which consists of a smooth calcified body found at autopsy in the tissues adjacent to but separate from the uterus. The structure almost certainly represents a calcified and parasitic leiomyoma

'eggshell' distribution (Figs 30.9 and 30.17 to 30.19). The former happens when the persistence of some circulation permits multifocal deposits in the centre of the leiomyoma and the latter when it is completely avascular and necrotic.

A calcified subserous leiomyoma can become detached from the uterus and be found wrapped in omentum or elsewhere in the abdominal cavity (Fig. 30.25).

#### *Red Degeneration; Necrobiosis*

This is mostly seen during pregnancy and the puerperium but can occur at other times. It manifests itself typically about midpregnancy when the leiomyoma *suddenly* becomes acutely painful, enlarged and tender. The patient may vomit and become generally ill with malaise and slight pyrexia. The condition can be mistaken for torsion of the pedicle of a leiomyoma or ovarian cyst, *abruptio placentae*, acute pyelitis or for any abdominal catastrophe.

The changes in the tumour are striking. It is soft and homogeneous or necrotic, especially in its centre, and is diffusely stained red or salmon pink. A fishy smell, described in the past, is rare and probably denotes secondary infection with coliform organisms. Histologically the degenerated area appears structureless and

poorly stained, and there is evidence of thrombosis in some of the vessels. The pathogenesis is obscure but the initial change appears to be one of subacute necrosis which is presumably caused by an interference with the blood supply. Some say that arterial or venous thrombosis is the basis of this, and that the lesion is essentially the result of infarction. The coloration is due to haemoglobin so the blood is either haemolysed in the vessels before it escapes or after it has been extravasated. The haemolysing factor is probably a lipid substance formed as a result of the original necrosis. On ultrasound the myoma shows a mixed echodense and echolucent appearance.

Red degeneration occurring during pregnancy is treated conservatively. The patient is put at rest in bed and given analgesics to relieve the pain. The acute symptoms subside gradually during the course of 3-10 days and the pregnancy then usually proceeds uneventfully.

When a leiomyoma which has suffered red degeneration or partial necrosis is removed several months after the acute episode, it sometimes presents as an encapsulated yellowish or putty-coloured soft amorphous mass. This is the so-called *wash-leather leiomyoma*.

#### **Haemangioma and Allied Tumours**

These are rare. A haemangioma of the endometrium, although benign, usually spreads to involve the myometrium but does not cause significant enlargement of the uterus. It consists of a complicated but localised network of well-formed blood vessels — venous, capillary and arterial — and there may be arteriovenous shunts and small aneurysms. So lesions of this kind are variously described as *angiomas*, *cirroid aneurysms* and *hamartomas*.

The main, if not the only, symptom is excessive uterine bleeding which can be alarmingly heavy. The haemangioma is not usually revealed by diagnostic curettage or hystero-graphy and, since the menorrhagia does not respond to any of the usual remedies, empirical hysterectomy eventually becomes necessary. Examination of the uterus then reveals the diagnosis which is rarely made or entertained before operation. If the diagnosis is suspected on analysis of the symptoms, it may be confirmed by angiography, and it can then be successfully treated by embolisation.



### Other Rare Benign Tumours

These include tumours consisting of gliomatous, cartilaginous or osseous tissue. They can be the outcome of endometrial metaplasia but most often they represent pieces of foetal tissue left in the uterus after instrumental termination of pregnancy. Such tissue can not only remain alive but can proliferate and become polypoidal to cause bleeding and discharge from the uterus. Since the lesions are superficial, curettage alone is often curative.

## MALIGNANT NEOPLASMS

### Carcinoma of the Endometrium

#### *Incidence*

Endometrial carcinoma occurs in women in the 6th and 7th decades of life. 75 per cent cases occur in women over 50 years. The risk of endometrial cancer is increased 3 times in women who are moderate overweight and 10 times more in grossly overweight. The incidence of endometrial carcinoma is about 2-3 per cent.

#### *Aetiology*

Endometrial cancer appears to have two distinct pathogenetic types. The first and commoner variety is seen in younger, perimenopausal women, is oestrogen dependent, starts in a background of endometrial hyperplasia and is better differentiated with a more favourable prognosis. Most of the risk factors identified for endometrial cancer are related to prolonged, unopposed oestrogen stimulation of the endometrium and are related to this type. The second type is seen in older, postmenopausal, thin women with no source of oestrogen stimulation of the endometrium, is associated with endometrial atrophy, is less differentiated and has a poorer prognosis. This type is seen more often in African and Asian women.

Some of the risk factors are discussed below.

#### *Age*

Carcinoma of the body of the uterus occurs at a later age than carcinoma of the cervix, the peak incidence being in women aged 60 years. Nevertheless, it arises before the menopause in 25 per cent of cases, sometimes in the comparatively young.

#### *Parity*

Unlike carcinoma of the cervix it is often seen in nulliparous women and in virgins. From 25 to 50 per cent of cases occur amongst nulliparae, the relative risk being 2-3 times, and many of the others among women who have had few pregnancies. The low fertility association probably explains why leiomyomas and carcinoma of the body of the uterus sometimes occur together (Fig. 30.26).

#### *Race*

Unlike malignant disease of the cervix, endometrial carcinoma is more common in Jewesses than in women of other races.

#### *Diabetes Mellitus and Metabolic Errors*

There is a significant association between diabetes and endometrial cancer. Fifty per cent of patients suffering from endometrial carcinoma can be shown to have abnormal glucose tolerance curves, and 10-30 per cent are frankly diabetic, the relative risk being 1.3-3 times. A disturbed glucose metabolism can often be demonstrated in menopausal and postmenopausal women known to have endometrial hyperplasia. It is the obese diabetic woman who is most vulnerable; indeed,



**Fig. 30.26:** A carcinoma of the endometrium filling the uterine cavity with its common associate - a leiomyoma

obesity alone is a predisposing factor. Women who are 10-20 kg overweight have a 3-fold risk, which increases to 10-fold if they are more than 25 kg overweight, because of the increased peripheral conversion of androstenedione to oestrone by aromatisation in fat. The combination of diabetes, obesity and hypertension, in association with endometrial carcinoma, is sometimes called the *corpus cancer syndrome*. A causal relationship with hypertension and hypothyroidism has not been confirmed.

#### *Oestrogens: Hyperplasia of the Endometrium*

Hyperplasia of the endometrium is often found in association with carcinoma, and all histological stages between simple hyperplasia and anaplastic carcinoma can be demonstrated. Cystic glandular hyperplasia of the endometrium is not a precursor of endometrial adenocarcinoma. Atypical hyperplasia with cellular atypia (almost invariably combined with architectural atypia) does not necessarily progress to carcinoma and about 20 per cent of cases will regress with progestogen therapy. Nevertheless, it has been estimated that approximately 40 per cent of cases of atypical hyperplasia with cellular atypia, particularly if of severe degree, progress to invasive carcinoma, the increase in risk being 8-29-fold.

It is not uncommon to see endometrial carcinoma in women who have had prolonged and haphazard oestrogen therapy (*see* Fig. 41.5); who suffer from oestrogenic tumours of the ovary; who have had a late menopause (R.R. 2-3 if after 52 years compared with those attaining menopause before 49 years); or who have had ovarian dysfunction as manifested by the polycystic ovary syndrome. Again, the woman who suffers from menopausal bleeding is said to have a three times increased chance of developing adenocarcinoma of the corpus uteri subsequently.

The incidence of endometrial carcinoma increases in any group of women given oestrogen alone as hormone replacement therapy (R.R. 4-8). It is for this reason that all hormone replacement therapy includes a progestogen in women with an intact uterus.

#### *Tamoxifen*

The use of the anti-oestrogen tamoxifen as long-term adjunctive therapy in patients of breast cancer has been associated with a large number of cases of endometrial

hyperplasia and a 2-3-fold increased risk of endometrial cancer. However, these cancers are usually well-differentiated.

#### *Senile Endometritis and Pyometra*

Atrophic and senile changes in the endometrium also favour the disease as explained above. It may occur after bilateral oophorectomy. Senile endometritis and pyometra acting as chronic irritants may provide a precipitating factor in predisposed individuals.

#### *Pathology: General Considerations*

Leiomyomas are found in 30 per cent of uteri which harbour cancer of the corpus. Cervical polyps are also common associates. The growth is one of the endometrium and is nearly always columnar-celled with varying degrees of differentiation and anaplasia, but it can be squamous-celled or mixed (*see below*). Different pictures may be present in different areas of the tumour; for this reason the appearances seen in curettings do not necessarily reflect those present in the actively invading edge of the cancer. The disease occurs in preinvasive and invasive forms.

#### **Adenocarcinoma *in situ* of the Endometrium**

##### *Pathology*

There is considerable debate as to whether the term adenocarcinoma *in situ* can be applied to the endometrium. If the term is limited to the presence of intraepithelial neoplasia, then clearly it cannot be applied to any lesion which has resulted in stromal invasion, whether that invasion is limited to the stroma of the endometrium or has extended into the myometrium. If, on the other hand, it has extended to include lesions which have resulted in endometrial stromal invasion and which should, more properly, be called intraendometrial carcinomas, then it must be made clear that the term as it applies to the endometrium is not synonymous with adenocarcinoma *in situ* of the cervix, for example, where the term is applied strictly to an abnormality of the epithelium believed to represent preinvasive malignancy.

On balance, the term has such limited application in the endometrium, and when correctly applied refers only to states of cytological atypia usually occurring against a background of atypical hyperplasia, that I think it is

preferable to use the term atypical hyperplasia for those forms of endometrial hyperplasia having both architectural and cytological atypia (Figs 30.27A to C). It must be stressed that it is extremely difficult for the pathologist to differentiate between severe atypical hyperplasia of the cellular variety and a well-differentiated adenocarcinoma. In many instances it is impossible to distinguish between severe cellular atypia and a well-differentiated carcinoma in material obtained by curettage and it may still be very difficult in a hysterectomy specimen in the absence of obvious myometrial invasion.

Clinically, there is little to be gained by having a diagnosis of an *in situ* lesion. It is the patient's age and symptoms in conjunction with any assessment of the curettings which determine whether a conservative policy of reassessing after a period of progestogen therapy or a radical policy of hysterectomy is followed.

### Invasive Carcinoma of the Endometrium

#### Pathology

The vast majority of endometrial neoplasms are adenocarcinomas (Table 30.1).

#### Adenocarcinoma

Macroscopically, endometrial cancer can be predominantly polypoidal into the cavity or invasive (Figs 30.26 and 30.28). Sometimes it is found only in a polyp. It may occupy a small area and be completely removed during curettage so that subsequent hysterectomy produces a uterus in which no cancer can be found. Multiple foci of origin in a growth are not uncommon.

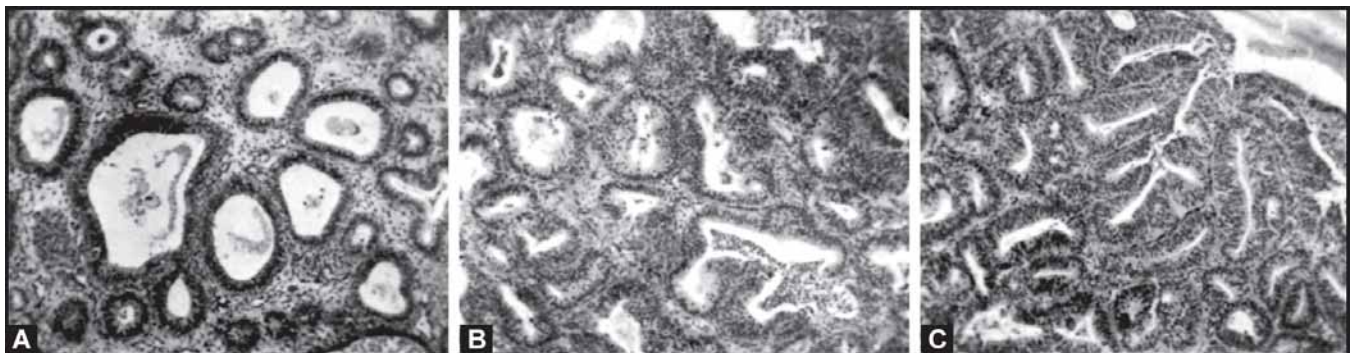
**Table 30.1: Classification of endometrial carcinoma**

- Endometrioid adenocarcinoma
  - Well-differentiated
  - Villoglandular/papillary
  - Secretory
  - With squamous differentiation
- Mucinous adenocarcinoma
- Papillary serous carcinoma
- Clear cell carcinoma
- Squamous carcinoma
- Poorly differentiated carcinoma

The growth bleeds and becomes infected, and the senile myometrium cannot easily expel the resulting discharges, especially when the cervix is stenosed or obstructed by debris. Pyometra and haematometra are therefore common complications (Figs 30.28 and 30.29).

Histologically most adenocarcinomas are well-differentiated columnar-celled cancers which preserve their glandular pattern but invade both stroma and myometrium (Fig. 30.30). Areas of necrosis, haemorrhage and leucocytic infiltration are common. A minority of endometrial adenocarcinomas are less well differentiated and tend to show areas of solid growth, less gland formation and more cytologic atypia; while a few are completely anaplastic.

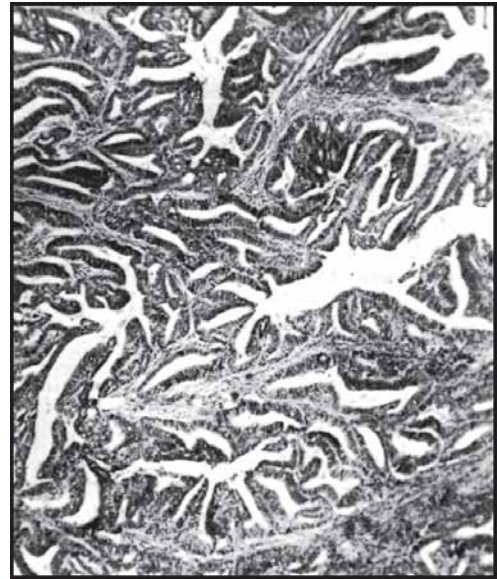
Back-to-back arrangement of glands without intervening stroma, desmoplastic stroma, extensive papillary pattern and squamous epithelial differentiation are criteria that indicate the presence of invasion and are used to diagnose carcinoma. However, it may be difficult to differentiate well-differentiated endometrial carcinoma from atypical hyperplasia. The



**Figs 30.27A to C:** Aspects of atypical endometrial hyperplasia. (A) Minimal glandular architectural atypia. (B) Minor degree of glandular architectural atypia with a moderate degree of cytological atypia. (C) Severe architectural and cytological atypia



**Fig. 30.28:** An ulcerative carcinoma of the body of the uterus with deep invasion of the myometrium. The cavity of the uterus below the growth is distended because it was the seat of a pyohaematometra



**Fig. 30.30:** A well-differentiated adenocarcinoma of the endometrium



**Fig. 30.29:** An adenocarcinoma arising in the region of the isthmus of the uterus and blocking the cervix to cause a haematometra above the growth



**Fig. 30.31:** Endometrial adenocarcinoma with squamous metaplasia (adenocarcinoma). To the right is seen the complex glandular pattern of well-differentiated (histological grade 1) endometrioid endometrial adenocarcinoma. To the lower left, large pale cells form part of the lining of an acinus; these are benign squamous cells. (Photomicrograph x150)

differentiation of tumours into grades (FIGO) is described elsewhere.

About 15-25 per cent of adenocarcinomas contain foci of squamous metaplasia. Those tumours in which squamous metaplasia is prominent or conspicuous (more than 10 per cent of the tumour) were earlier placed in a separate category, namely adeno-acanthoma (Fig. 30.31). If the squamous elements looked malignant, they were called adenosquamous carcinomas. The term '*endometrial*

*carcinoma with squamous differentiation* is now used instead of these terms as the differentiation of the squamous component is usually similar to the glandular and it is the latter which determines the prognosis.

Other minor variations of the endometrioid adenocarcinomas are those with the *villoglandular or papillary* configuration (2%) and the *secretory* carcinoma (about 1%). The villoglandular carcinoma needs to be differentiated from the papillary serous carcinoma which has a poorer prognosis, and the secretory from the clear cell carcinoma.

All the above are types of endometrioid adenocarcinomas which account for 80 per cent of endometrial malignancy. Other endometrial carcinomas are the mucinous, papillary serous, clear cell, squamous, undifferentiated and mixed carcinomas.

Mucinous adenocarcinomas comprise about 5 per cent of endometrial carcinomas. Over half the tumour has cells with intracytoplasmic mucin. The tumour has a good prognosis and needs to be distinguished from endocervical adenocarcinoma. A primary endometrial tumour can be diagnosed by the following: merging with areas of normal endometrium, presence of endometrioid carcinoma, squamous metaplasia or foamy endometrial stromal cells; positive perinuclear immunohistochemical staining with vimentin.

Papillary serous carcinomas comprise 3-4 per cent of endometrial carcinomas. They have branching papillae with a thin fibrovascular core and columnar cells with nuclear atypia. They have a very poor prognosis and are usually seen in elderly hypo-oestrogenic women. They account for up to half the deaths from endometrial carcinoma. They resemble serous carcinoma of the ovary and fallopian tube morphologically. Behaviourally, they are often associated with lymph-vascular space and deep myometrial invasion, and, like ovarian carcinoma, spread intra-abdominally. The presence of lymph node metastases, positive peritoneal cytology and intra-peritoneal tumour does not correlate with the degree of myometrial invasion.

Less than 5 per cent of endometrial carcinomas are of the clear cell type. It usually has a mixed histological pattern including tubules, papillae, solid sheets and glands. This tumour also occurs in older women and has a poorer prognosis than the papillary serous carcinoma.

#### *Squamous Carcinoma*

This is rare and has to be distinguished from cervical cancer: there should be a connection with the cervical epithelium in the latter case. It has a very poor prognosis.

## Spread

### *Direct Invasion*

The tumour usually grows slowly, especially when it is well-differentiated and when it occurs in old age. It gradually infiltrates the myometrium but may take several years to reach the peritoneal coat. This indolence is sometimes attributed to a barrier of polysaccharides in the uterine wall.

Ultimately the tumour protrudes on the outer surface of the uterus and invades the broad ligament and adjacent organs. Downward spread to the endocervix can occur.

### *Lymphatic*

Permeation of lymphatics probably accounts in part for some of the *local* spread, to the tubes and ovaries for example, and *possibly* to the upper vagina.

Involvement of the lymph nodes occurs relatively late, although not so late as was formerly believed. The nodes affected are the para-aortic group via the ovarian lymphatics, and the internal, external and common iliac groups via the uterine lymphatics. Occasionally, the route follows the round ligaments to the superficial inguinal nodes. Pelvic wall lymph node involvement is reported in 10-15 per cent of cases coming to operation. It varies from nil, when the cancer is limited to the endometrium, to up to 40 per cent if it invades the myometrium to within 1-2 mm of its peritoneal coat. The chance of finding cancer cells in the nodes also increases with the degree of anaplasia shown by the tumour. Thus, for tumours infiltrating the inner third of the myometrium the risk of pelvic node metastasis is substantial for grade 3; for tumours infiltrating the middle third of the myometrium the risk is substantial for grades 2 and 3; and for tumours infiltrating the outer third of the myometrium the risk is substantial for all grades of tumour.

In Boronow's study, when pelvic nodes are negative, para-aortic nodes are reported to be positive for metastatic tumour in 1.5 per cent of cases. When pelvic nodes are positive, the incidence of para-aortic lymph nodes being involved increases to 60 per cent.

In cases coming to autopsy, and including early cancers not considered responsible for the patient's death, malignant lymph nodes are found in 50 per cent of cases - as frequently above as below the pelvic brim.

### Bloodstream

Embolism accounts for remote secondaries and for certain deposits in the pelvis, notably those which occur low on the anterior vaginal wall.

### Seeding

Tubal washings in cases of carcinoma of the uterus frequently disclose the presence of malignant cells, and retrograde spill was once favoured as the mechanism whereby metastases arise in the ovaries as well as in the tubes. Lymphatic permeation is a more popular theory, if only because ovarian deposits are deep seated and not on the surface. Peritoneal washings from the pouch of Douglas may reveal malignant cells on cytological examination.

Cancer cells also spill from the undisturbed uterus into the vagina and can be picked up on vaginal cytology. It was once believed that cellular spill accounts for the development of vaginal metastases. Those in the lower vagina, however, undoubtedly represent vascular embolism. What of those found in the vaginal vault? These *never* occur except after hysterectomy for endometrial carcinoma so it is difficult to believe that they arise in any way except by seeding.

### Metastases

Vaginal metastases develop in 10-15 per cent of cases. Those in the lower vagina are almost invariably suburethral in site and can arise before or after hysterectomy; those in the upper vagina only occur after this operation (*see above*). The appearance of post-operative metastases in either site may be delayed for 3-4 years but, in 50 per cent of cases, it is within one year.

Ovarian secondaries, nearly always bilateral, are found in 3 to 5 per cent of cases coming to surgery. Some may not be 'secondaries' however, and the same is true for rare cancers of the tube associated with endometrial cancer. Which is primary and which is secondary? This question is discussed elsewhere.

Extrapelvic metastases in the lungs, brain and elsewhere are rare and usually late manifestations.

### Clinical Features

The only symptom of endometrial cancer as a rule, is irregular bleeding and discharge occurring in a perimenopausal or postmenopausal woman. About 10 per cent of cases of postmenopausal bleeding have

endometrial cancer, but over 90 per cent of cases of endometrial cancer present with abnormal bleeding. In approximately 1 per cent of cases the discharge is free from blood (*hydrorrhoea*); otherwise it is brown, watery and offensive. The bleeding is not usually heavy, as it is in carcinoma of the cervix. Occasionally the patient passes a piece of polypoid growth *per vaginam* (Fig. 30.33).

Pain of an extraordinary character ('Simpson's pain') is noted by 15 per cent of patients. Referred to the hypogastrium or to both iliac fossae, it is not severe, and *tends to appear at the same time each day lasting only 1-2 hours*. It is probably caused by expulsive uterine contractions. Less than 5 per cent of patients are asymptomatic, or detected by Pap smear, at ultrasound, CT scan or hysterectomy for some other problem.

General physical examination is directed towards looking for obesity, hypertension, breast lesions and peripheral lymphadenopathy (supraclavicular, axillary and inguinal). It is important to palpate these lymph nodes. In advanced cases, abdominal examination may reveal ascites, hepatic or omental metastases. Per speculum examination is done to inspect the vulva, vagina and cervix.

On bimanual examination, the uterus ordinarily feels small and shows no obvious departure from the normal senile state. It can, however, be enlarged by growth or by pyohaematometra, and in advanced cases it is irregular and fixed. When the uterus is palpably abnormal the condition is usually far advanced if not hopeless. Palpation of the Bartholin's gland, vagina, adnexa and of the parametrium by rectovaginal examination is important to assess spread of the disease, if any.

### Diagnosis

Endometrial carcinoma has to be distinguished from endometrial hyperplasia, carcinoma of the cervix and all other causes of irregular bleeding and discharge. Every woman presenting with suggestive symptoms requires further investigation to establish the diagnosis.

### Cytodiagnosis

Cytological studies of material obtained by vaginal aspiration may raise suspicion but they are not methods for diagnosing endometrial carcinoma. Only 30-50 per cent of patients with endometrial carcinoma have positive Pap tests and they are women with advanced disease.

### Endometrial Aspiration

This is now the first step in making the diagnosis. It has the advantage that it can be done as an out-patient procedure without anaesthesia. The plastic cannula is also less likely to perforate the senile uterus invaded by growth than is the metallic curette. The diagnostic accuracy is 92-98 per cent when compared with subsequent dilatation and curettage (D&C) or hysterectomy. Endometrial aspiration is combined with endocervical curettage to rule out cervical pathology.

### Hysteroscopy and D&C

Hysteroscopy and D&C are not recommended routinely. D&C is advised in patients with cervical stenosis, if the specimen obtained is inadequate, especially if the clinical suspicion of malignancy is high, or if bleeding recurs after a negative report on endometrial aspiration. In the last mentioned situation, if small growths are missed with the curette or where polyps are present, hysteroscopy aids by allowing direct visualisation and a guided biopsy.

The curettings are subjected to histological examination but to the expert, their naked-eye characteristics can be diagnostic. Malignancy is suggested if the curettings are profuse, friable, if they appear as cheesy lumps rather than strips, and if they are dark in colour. Failure of the uterine wall to 'grate' in response to the curette is also suspicious.

### Transvaginal Ultrasound and Saline Infusion Sonography

Transvaginal ultrasound is more accurate in delineating endometrial lesions and in evaluating myometrial invasion than is the transabdominal route. The finding of an endometrium greater than 4 mm in thickness, a polypoid mass or a collection of fluid within the uterus is helpful in differentiating those patients who need further endometrial evaluation from those whose bleeding is likely to be caused by atrophy. Most studies suggest that an endometrial thickness of less than 4 mm in the postmenopausal woman is not associated with any endometrial lesion, but further investigation is required if the symptoms are recurrent. The instillation of fluid into the endometrial cavity (sonohysterography or saline infusion sonography) helps in the diagnosis of endometrial polyps (Figs 30.32A and B).

There are concerns that the instillation of fluid during hysteroscopy and sonohysterography may aid the dissemination of malignant cells into the peritoneal cavity. Although this is not clearly proved, these procedures are best avoided when there is a high index of suspicion for malignancy, unless absolutely necessary for diagnosis.

### CT Scan and MRI

CT scan of the abdomen and pelvis is not routinely recommended. It can be used for staging of the disease



**Fig. 30.32A:** Transvaginal sonogram shows an appearance of a thickened endometrium with irregular cystic spaces. The patient was receiving tamoxifen for breast cancer for the last 2 years



**Fig 30.32B:** Saline infusion sonography in the same patient. The endometrium is normal, the cystic spaces are now seen to be tamoxifen-induced subendometrial spaces. A polyp is seen projecting into the endometrial cavity. This was confirmed and resected at hysteroscopy

in those women who are not suitable for surgery. MRI has the best sensitivity for assessing myometrial invasion. Thus both ultrasonography and MRI can be used to plan the surgical procedure with regard to lymph node sampling.

#### Serum CA-125

Serum CA-125 levels are usually normal in Stages I and II. With extrauterine spread and peritoneal involvement, higher levels are found.

### Staging

Clinical staging is performed only in those few patients who are not fit for surgery because of poor general condition or spread of the disease, i.e. gross cervical involvement, parametrial spread, invasion of the bladder and/or rectum or distant metastases. In general, surgical staging should be carried out (*see below*). The surgical staging accepted by the International Federation of Gynaecology and Obstetrics (FIGO), 1988, is as follows:

Stage IA	Tumours limited to the endometrium
IB	Invasion to less than one-half of the myometrium
1C	Invasion to more than one-half of the myometrium
Stage IIA	Endocervical glandular involvement only
IIB	Cervical stromal invasion
Stage IIIA	Tumour invades serosa and/or adnexa and/or positive peritoneal cytology
IIIB	Vaginal metastases
IIIC	Metastases to pelvic and/or para-aortic lymph nodes
Stage IVA	Tumour invades bladder and/or bowel mucosa
IVB	Metastases to intra-abdominal and/or inguinal lymph nodes; distant metastases.

Each of the stages is divided into three grades, determined by the architectural growth pattern and nuclear features:

Grade 1	<5 per cent non-squamous or non-morular growth pattern
Grade 2	6 to 50 per cent non-squamous or non-morular growth pattern
Grade 3	>50 per cent non-squamous or non-morular growth pattern

Adenocarcinomas with squamous differentiation are graded according to the nuclear grade of the glandular

component. In serous, clear cell and squamous cell carcinoma, nuclear grading takes precedence over architectural grade. Notable nuclear atypia, inappropriate for the architectural grade, raises the grading of a Grade 1 or 2 tumour by one grade in all varieties of tumour.

### Prognosis

On the whole, endometrial carcinoma offers better prospects for cure than any other malignant growth in any site in the body. This is because the cancer is often indolent, it is contained for long periods by the thick myometrium, and spread to the lymph nodes is relatively late. The symptoms of postmenopausal bleeding or intermenstrual bleeding also mean that patients are referred to the specialist earlier, usually within 3 months.

The most important factors governing the outlook for a particular patient are: the stage of the disease; the degree of anaplasia shown by the growth; involvement of lymph nodes, which is determined by the stage of the disease and the degree of anaplasia; the size of the growth and the encroachment of the tumour into the cervix; the presence of associated diseases such as diabetes, obesity and hypertension, which may influence treatment; and the availability of the best therapeutic facilities.

#### Treatment

Pre-treatment evaluation of the patient includes complete blood counts, serum chemistry, renal and liver function tests, urinalysis, blood type, chest X-ray, electrocardiogram and CA-125 levels. Ultrasound or MRI can assess myometrial invasion accurately. Unlike cervical cancer, cystoscopy, proctosigmoidoscopy, intravenous pyelography and CT scanning of abdomen and pelvis are not indicated unless suggested by the clinical features or laboratory tests.

#### Surgery

In Stages I and IIA, the treatment of choice is an extrafascial total abdominal hysterectomy and bilateral salpingo-oophorectomy with lymph node sampling. A lower abdominal midline vertical incision is most often used, but a transverse muscle-dividing one (Maylard) is also used by some.

The procedure includes peritoneal cytology, thorough exploration of the abdomen and pelvis and biopsy of extrauterine lesions followed by extrafascial



hysterectomy and bilateral salpingo-oophorectomy. Removal of a vaginal cuff is not necessary. The cut section is examined for tumour size, depth of myometrial invasion and extension to the cervix. If the tumour histology is already known to be clear cell, serous, squamous or poorly differentiated Grade 3 endometrioid, and if the cut section shows that the myometrium has been invaded to more than half its thickness, or the tumour has extended to the cervix or the isthmus, or the tumour size is >2 cm, or there is evidence of extrauterine disease, pelvic lymph node sampling of even clinically negative lymph nodes is mandatory. Suspicious pelvic and para-aortic lymph nodes should be removed in all cases and sent for histopathological evaluation.

The specimen is sent for histopathological examination and, if possible, for measurement of steroid hormone receptors and flow cytometry.

Laparoscopically assisted vaginal hysterectomy (LAVH) with bilateral salpingo-oophorectomy and laparoscopic retroperitoneal lymph node sampling is being done at certain centres, which reduces the hospital stay and the overall complication rate, although the possibility of serious complications, e.g. ureteral injury, small bowel herniation through 12 mm ports, etc. may be increased.

Radical hysterectomy has no place in the management of early endometrial cancer. For Stage II tumours, radical hysterectomy with bilateral salpingo-oophorectomy and pelvic lymphadenectomy has long been the standard practice but it now appears that the standard surgical approach as described for Stage I disease, followed by appropriate pelvic or extended field external and intravaginal irradiation can give equally good results.

Similarly, for Stage III growths, the goal of surgery is total abdominal hysterectomy and bilateral salpingo-oophorectomy with selective lymphadenectomy, biopsies of suspicious areas, omental biopsy and debulking of tumour, followed by radiotherapy.

Treatment has to be individualised in those with Stage IV tumours. Usually a combination of surgery, radiotherapy, hormonal therapy or chemotherapy is required. The objective is usually to control pelvic disease and offer palliation, but selected cases with central disease limited to the bladder or rectum may be suitable for pelvic exenteration.

Surgery alone will suffice for patients with Stage IA G1 or G2 tumours in whom there is no invasion of the lymph-vascular space, cervix or isthmus, peritoneal cytology is negative and there is no evidence of metastasis. The 5-year survival rate in these patients is 100 per cent. All other patients require some form of adjuvant radiotherapy.

### Surgery and Radiotherapy

Postoperative vaginal vault irradiation is recommended in the following cases: Stage IA G3 tumours; Stage IB G1 and G2 tumours. By this method the incidence of vaginal vault recurrence can be reduced significantly from 15 per cent to less than 2 per cent, and the 5-year survival rate can be correspondingly increased from 75 per cent to 90 per cent.

Patients with Stage IB G3, and Stage IIA G1 and G2 tumours are given either pelvic irradiation or vaginal cuff irradiation. For those with tumours in Stage 1C (all grades), Stage IIA G3, Stage IIB (all grades), Stage IIIA (all grades) or with lymph-vascular space invasion, external pelvic irradiation of 50 Gy is recommended in addition to vaginal irradiation. This may also be suitable for selected Stage IVA patients. All patients with positive pelvic lymph nodes receive external pelvic irradiation.

The significance of positive peritoneal cytology is unclear. Although this places the tumour in Stage IIIA, the management of this group of patients is not clearly defined. Progestins and P<sup>32</sup> therapy have both been tried but the benefits have not yet been clearly demonstrable.

Patients with documented para-aortic and common iliac node involvement are additionally given extended field irradiation of 45 Gy. Patients with Stage IV disease with intraperitoneal spread may require whole abdomen irradiation along with systemic chemotherapy (*see below*). Whole abdomen irradiation (30 Gy) is also sometimes given in cases of papillary serous tumours which are likely to have upper abdominal spread.

### Radiotherapy Alone

This is used in 5-15 per cent of patients who are unfit for operative treatment or when the growth is too advanced for surgery. Various techniques are employed but the main principle is to give a larger dose to the uterine cavity than in cervical cancer. Vaginal vault applications are sometimes used as well and the outer areas of the pelvis

can be covered by conventional external beam therapy. The total dose is similar to that used for carcinoma of the cervix. The results of radiotherapy alone are generally inferior to those obtained with other methods and most centres can obtain no more than 45-60 per cent (65% for Stage I) apparent 5-year cure rates. It has to be accepted that the patients are preselected as being advanced cases or poor surgical risks.

### Chemotherapy and Hormone Therapy

Disseminated metastatic disease found either at the initial operation or as a recurrence requires systemic therapy. The efficiency of progestogen therapy in producing objective responses has been reported in approximately 30 per cent of patients with metastatic endometrial carcinoma. The ideal patient for hormone therapy is one whose metastatic disease recurs a few years after the original treatment, particularly when the lesion is well-differentiated. If facilities are available for assessing progesterone and oestrogen receptors, such an assessment will provide a guide as to the most appropriate cytotoxic therapy. We now use progestins in all patients with recurrent endometrial cancer. No difference has been observed with the type, dose or route of administration. Medroxy-progesterone acetate 50-100 mg orally three times daily or megestrol acetate 80 mg twice daily are administered for two to three months. The anti-oestrogen tamoxifen, 20 mg twice daily, may be of benefit when the tumour is oestrogen receptor-positive, even if progestogen therapy has failed. Tamoxifen increases the progestogen receptors in the uterus. The combined use of tamoxifen and progestins does not have any greater benefit than progestins alone.

There is considerable debate as to whether progestogen therapy should be given to all cases. If peritoneal washings are positive and there is no other evidence of spread, it may be used but there is no obvious benefit when progestins are used as primary therapy.

Chemotherapy in the form of cyclophosphamide, actinomycin D and cisplatin has not been as effective as anticipated. Partial response rates of 38 to 76 per cent are reported, with a median survival of less than 12 months.

### Treatment of Vaginal Metastases

If nodules of growth arise in the vagina after operation, they are treated by irradiation (if this has not been used

previously) or by local excision, and the results can be surprisingly good; some women live several years in comfort thereafter. A few patients may have exenterations performed if the recurrence is localised.

### Results and Follow-up

Overall 5-year survival rates for those with growths in Stages I and IIA vary from 83 to 96 per cent, depending on the grade of the tumour. Those with Grade 3 tumours in Stages 1C and IIA have a survival rate of about 73 and 60 per cent, respectively.

For those in Stages IIB and IIIA, survival rates vary between 55 and 77 per cent, depending on the grade. It decreases to 42 to 59 per cent in Stage IIIC and 18 to 35 per cent in Stage IV.

Follow-up is best done by history and examination – 3-monthly for the first 2 years and 6-monthly thereafter. Nearly 80 per cent of recurrences can be detected by clinical methods. Chest X-ray done every 6-12 months can detect asymptomatic recurrences. CA-125 is useful as a marker but less so in the case of very early disease. Intravenous pyelography and CT scans are not indicated for routine follow-up.

### Choriocarcinoma

Discussed elsewhere.

### Sarcoma of the Uterus

Sarcomatous growths occur in the body of the uterus and in the cervix; both sites can be considered together. Uterine sarcomas are rare and represent not more than 1 per cent of malignant growths of the female genitalia, constituting about 2 to 6 per cent of uterine malignancies.

### Pathology

Sarcoma can arise from the stroma of the endometrium or from the connective tissue and muscle elements of the myometrium and cervix. They may be homologous or heterologous. Among the homologous are pure forms like the leiomyosarcoma and stromal sarcoma, or the mixed, i.e. carcinosarcoma. Among the heterologous are the pure forms like rhabdomyosarcoma, chondrosarcoma, osteosarcoma and liposarcoma, or the mixed, i.e. mixed mesodermal sarcoma or mixed müllerian tumour.

Mixed müllerian tumours make up about 40 to 45 per cent, leiomyosarcomas about 40 per cent, endometrial

stromal sarcomas 15 per cent and other sarcomas about 5 per cent of uterine sarcomas.

Endometrial stromal tumours include the benign endometrial stromal nodule and the endometrial stromal sarcoma. Two forms of endometrial stromal sarcoma are now recognised, low-grade and high-grade.

### Low-grade Stromal Sarcoma (Endolymphatic Stromal Myosis)

This interesting but rare myometrial tumour is composed of endometrial stroma. There is some dispute as to whether it is an invasion from the endometrium or whether it arises due to metaplasia of the myometrial cells. It is undoubtedly a stromal cell tumour showing a mass of round and oval cells with <10 mitotic figures per 10 hpf. This non-encapsulated tumour extends into the broad ligament and shows a peculiar tendency to permeate veins and lymphatics. When the uterus is removed, these extensions can be pulled out from the broad ligament as worm-like threads. Although distant metastases are uncommon the local recurrence rate is between 40 and 80 per cent and 5-25 per cent of the women die of the disease. Late recurrences may occur up to 25 years after the original diagnosis. Recurrences usually occur when the tumour has reached or breached the serosa.

### High-grade Stromal Sarcoma

These highly lethal tumours are less commonly associated with diffuse uterine enlargement and tend to have soft fleshy fungating masses protruding into the uterine cavity. Histologically the tumour is highly cellular and grows as sheets and cords of endometrial stroma-like cells that penetrate the myometrium extensively, with >10 mitotic figures per 10 hpf. The 5-year survival rate is approximately 25 per cent.

### Leiomyosarcoma

These occur at a younger age than other uterine sarcomas, usually between 43 and 53 years. Sarcomatous change is reported to occur in 0.13-0.8 per cent of benign uterine leiomyomas. Up to 4 per cent of patients may have received pelvic radiotherapy previously. Two-thirds of leiomyosarcomas are intramural, poorly circumscribed and cannot be shelled from the surrounding myometrium. The cut surface is bulging,

soft, fleshy, focally necrotic and haemorrhagic. The tumour loses its whorled appearance.

Histologically, interlacing bundles of spindle cells with fibrillar cytoplasm, irregular and hyperchromatic nuclei and multiple mitotic figures are seen. The presence of coagulative tumour necrosis and pleomorphism are the most important diagnostic features specially when the diameter of the tumour is more than 5 cms.

Previously it was considered that tumours with >10 mitotic figures per 10 hpf are associated with a frankly malignant behaviour and survival rate of about 15 per cent versus 98 per cent if there are <10 mitotic figures per 10 hpf. The number of mitotic figures is now not considered to be as important a prognostic criterion as it was in the past, as it has been seen that it may decrease if there is a delay in fixing the specimen. Also, it can vary in different areas of the same tumour. The area covered by 1 hpf may also vary depending on the type of microscope.

Other variants of leiomyosarcoma which are seen from time to time are intravenous leiomyomatosis, benign metastasising leiomyoma, leiomyoblastoma, leiomyomatosis peritonealis disseminata and myxoid leiomyosarcoma.

#### *Spread*

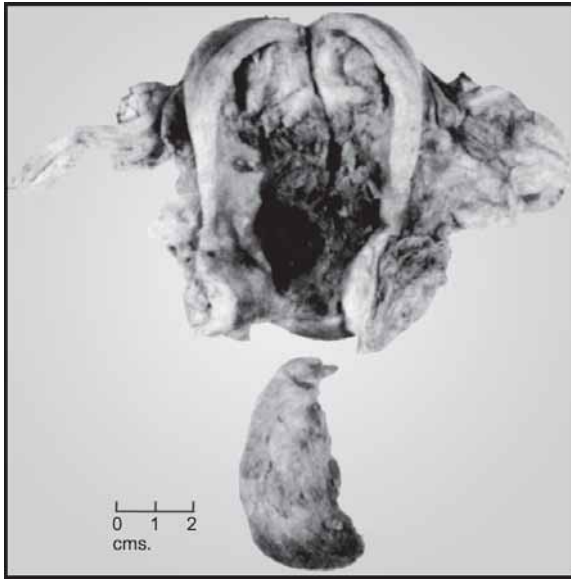
Apart from local invasion, sarcoma of the uterus spreads by the blood stream, the common site for metastases being the lungs.

#### *Clinical Features*

Sarcomas may present either in childhood as an abdominal swelling or in women aged 50-60 years. In the latter, the leading symptoms are irregular uterine haemorrhage and discharge. If the sarcoma is deep in the uterine wall bleeding may be absent.

The friable and polypoid nature of the tumour sometimes results in portions of it being passed per *vaginam*. If a patient brings a mass of growth with an account of having passed it spontaneously from the vagina it nearly always proves to be a sarcoma or, sometimes, an adenocarcinoma (Fig. 30.33).

The patient frequently complains of pain over the tumour, or of painful uterine contractions. Pyrexia is common and cachexia develops rapidly. The uterus is usually tender on palpation and palpably enlarged, although possibly softer and more cystic than in the cases



**Fig. 30.33:** The spontaneous extrusion of malignant growth *per vaginam*. This specimen of a uterus shows the cavity extensively involved in a malignant growth. Below is a mass of tissue which, having been passed vaginally, was brought by the patient when she first attended hospital. A happening of this kind suggests a sarcomatous lesion but, in this case, examination of the original tissue and of the uterus removed subsequently revealed adenocarcinoma only

of leiomyoma and adenomyosis with which the condition is likely to be confused.

Diagnosis can be made by biopsy of any projecting mass, or by endometrial aspiration if the tumour is submucosal (in about one-third of cases).

#### Treatment

The primary treatment of stromal sarcomas and leiomyosarcoma is surgical and, without this, the diagnosis is not likely to be made. Extension of the growth into other tissues often makes complete removal impossible and, even if it seems complete, the condition has a habit of recurring after total hysterectomy and bilateral salpingo-oophorectomy.

An exception to this is made in young, premenopausal women with leiomyosarcoma confined to the uterus. In these women the ovaries can be conserved.

Adjuvant postoperative radiotherapy is advocated in the case of endometrial stromal sarcomas even in early stage disease because of the high incidence of recurrences after apparently adequate surgical therapy. Leiomyosarcomas do not respond well to radiotherapy.

In Stage III tumours, chemotherapy is advocated as well. Combination chemotherapy with cyclo-phosphamide, vincristine, adriamycin and DTIC (CYVADIC) or ifosfamide with mesna uroprotection, adriamycin (doxorubicin) and DTIC (MAID) has been useful in the treatment of metastatic disease but the impact on survival is unclear, the overall survival rate being 15 to 25 per cent. Doxorubicin is especially useful in leiomyosarcomas.

Stage IV sarcomas are treated with only combination chemotherapy as outlined above.

Low-grade stromal sarcomas may respond to progestin therapy. Adjuvant radiotherapy may not be required in this group.

#### Mixed Müllerian Tumours

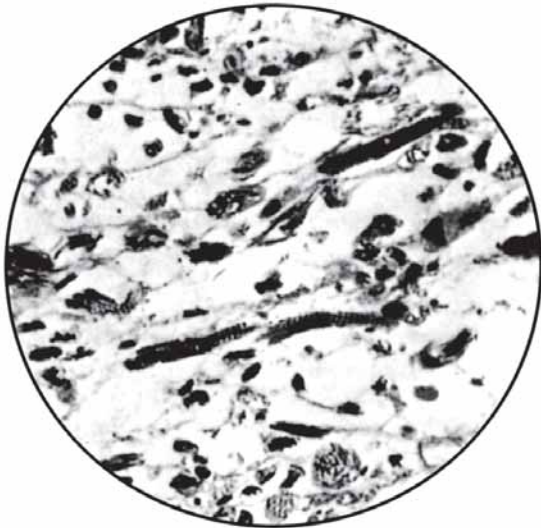
This group of tumours is considered here because it is uncertain whether they originate primarily in the endometrium or myometrium. Rarely, these tumours can also develop in the cervix and ovary. They are identical regardless of their origin.

The tumours arise from müllerian mesenchymal cells which differentiate into stromal and epithelial elements. If both components are benign, the tumour is known as a müllerian adenofibroma, but if both components are malignant, the tumour is called a malignant mixed müllerian tumour (or mixed mesenchymal sarcoma, mixed mesodermal sarcoma, among other names). If the epithelial element of a mixed tumour is benign and the stromal element malignant it is called a müllerian adenosarcoma; the alternative combination is rare.

The epithelial component of a mixed müllerian tumour is usually of a type found in the uterus but whilst the stromal component can differentiate into smooth muscle or endometrial stroma-like cells, it can differentiate into other tissues such as cartilage, striated muscle or bone (Fig. 30.34). The heterogeneous structure of these tumours reflects the capacity of the mesoderm of the müllerian ducts to differentiate in many directions, a potential retained by adult tissues.

#### Clinical Features

Despite their complexity, malignant mixed müllerian tumours occur principally in older women, the median age of incidence being 62 years. The presenting symptom is usually vaginal bleeding but pelvic pain and vaginal discharge are also common symptoms and fragments of necrotic tumour may be passed *per vaginam*.



**Fig. 30.34:** A malignant mixed müllerian (mesodermal) tumour with heterologous elements. A variety of malignant cells including conspicuous strap-like muscle cells with cross striations: these are rhabdomyosarcomatous elements

On examination, the uterus is invariably enlarged by a bulky, soft, fleshy, polypoidal tumour mass which tends to fill the uterine cavity and sometimes passes through the cervical canal to present in the vagina. The tumour contains foci of haemorrhage and necrosis.

The pattern of spread is similar to that for endometrial adenocarcinoma but the rate of progression is faster, for mixed müllerian tumours are highly aggressive. It is common for the tumour to have spread outside the uterus before the diagnosis is made and to involve the pelvic peritoneum and lymph nodes. Death is almost certain and rapid if the tumour has spread outside the uterus.

Treatment protocol is as for the high-grade endometrial stromal sarcoma, i.e. total abdominal hysterectomy and bilateral salpingo-oophorectomy followed by radiotherapy and chemotherapy, but response to chemotherapy is very poor.

The müllerian adenosarcoma is a much less malignant neoplasm and, although often developing in the same age group, tends to occur in younger women. The adenosarcoma is of relatively low-grade malignancy and, while pelvic or vaginal recurrences occur in about half the patients after hysterectomy, distant metastases are uncommon. Those patients with local recurrence often survive for prolonged periods.

Occasionally a mixed müllerian tumour is limited to a uterine polyp and there is no invasion of the myometrium. In these cases there may be a favourable outcome.

Overall, the 5-year survival rate is 20 to 30 per cent.

### Rhabdomyosarcomas

These occur in two locations in the female genital tract. Some are confined to the uterine myometrium and others arise in the cervix and vagina.

Vaginal rhabdomyosarcomas in young girls are usually referred to as sarcoma botryoides (grape-like). They usually present as an asymptomatic mass or the presenting symptom may be vaginal bleeding. Other symptoms are usually secondary to metastatic disease.

Sarcoma botryoides is an embryonal rhabdomyosarcoma originating in the subepithelial tissues of the vagina or cervix. As the polyps grow into the vaginal cavity they retain the original squamous epithelial covering of the vagina.

The growth spreads by direct extension to other organs, and via the bloodstream to produce secondaries especially in the lungs; in other words it behaves like a sarcoma. The degree of malignancy varies but is usually high. The typical sarcoma botryoides seen in children is often fatal, irrespective of treatment.

### Other Rare Uterine Tumours

#### *Melanoma*

Melanoma of the uterus is always a secondary growth even though it is sometimes difficult to locate the primary. It is a pathological curiosity.

#### *Haemangiopericytoma*

Both benign and malignant forms of this tumour of the uterine wall are described. It arises from pericytes and consists of masses of blood vessels, each surrounded by one or more layers of round, oval, or spindle cells.

Depending on its site, on encroachment of the uterine cavity, and on its benign or malignant nature, the condition causes symptoms similar to those of adenomyosis or endometrial carcinoma. The uterus is often palpably enlarged so the clinical diagnosis is usually leiomyoma or adenomyosis.

The true nature of the lesion is only revealed by histological examination of the specimen resulting from hysterectomy - which becomes inevitable sooner or later.

*Leukaemic and Lymphadenomatous  
Growths; Lymphomas*

These, formerly extremely rare, are occurring with increasing frequency. This is because the modern chemotherapy of leukaemias and of Hodgkin's disease is so efficient as to prolong life and to ensure remissions without always producing a cure. There is, therefore, much more opportunity for masses of leucoblastic or lymphomatous tissues to develop in the pelvic organs.

The commonest sites are the ovaries and tubes which become involved in large fixed tumours. The uterus, too, can be a site; the growths infiltrate its wall and extend

into the broad ligaments and other tissues to produce physical signs similar to those of advanced carcinoma of the cervix.

The development of ascites is often the lead to the lymphomatous tissue in the adnexa. Symptoms similar to those of cancer of the cervix or corpus draw attention to uterine involvement.

Knowledge that the patient is suffering, or has suffered, from leukaemia or lymphoma strongly suggests the diagnosis and this can be confirmed by biopsy of any growth which is accessible. The only treatment is as for the parent disease.

Benign Neoplasms	517
Secondary Malignant Neoplasms	517
Primary Malignant Neoplasms	517

## BENIGN NEOPLASMS

Apart from tiny peritoneal cysts and pseudocysts on the outer surface of the tube, benign tumours are exceptional. They occur in the form of fibroma, leiomyoma, haemangioma and the special *adenomatoid tumour*.

These are mostly small and asymptomatic so they are generally incidental findings at operation or at the examination of tubes removed for other reasons.

*Polyps* within the intramural portion of the tubes, revealed by salpingography, salpingoscopy, falloposcopy or at microsurgery, are described as common and are thought to cause infertility.

## SECONDARY MALIGNANT NEOPLASMS

Metastases are more common than primary growths; they arise by direct spread and seeding or by the lymph and bloodstream. The parent tumour is most often in the ovary, uterus or large intestine.

It can be extremely difficult, sometimes impossible, to say which is primary and which is secondary, especially when cancer of the tube is associated with endometrial carcinoma, with certain ovarian tumours or with the rare primary peritoneal carcinomatosis. Cancer cells pass along the tubes, and the lymphatic channels, in either direction.

## PRIMARY MALIGNANT NEOPLASMS

### Choriocarcinoma

Choriocarcinoma can arise after tubal pregnancy and is dealt.

### Sarcoma

Various cellular types, including the mesodermal mixed tumour, are recorded as rarities.

### Carcinoma

This is the commonest form of primary malignant growth in the tube *but*, even so, represents only 0.3 per cent of cases of genital cancer.

### Histopathologic Types

More than 90 per cent of Fallopian tube carcinoma is papillary serous adenocarcinoma. Other tumours include clear cell carcinoma and endometrioid carcinoma. All these are treated essentially the same way. Rare types include sarcoma, germ cell tumours and lymphoma.

### Histopathologic Grades

- GX — Grade cannot be assessed
- G1 — Well differentiated (papillary)
- G2 — Moderately differentiated (papillary-alveolar)
- G3 — Poorly differentiated (alveolar-medullary)

### Regional Nodes (N)

- NX Regional lymph nodes cannot be assessed  
 N0 No regional lymph node metastasis  
 N1 Regional lymph node metastasis

### Distant Metastasis (M)

- MX Distant metastasis cannot be assessed  
 M0 No distant metastasis  
 M1 Distant metastasis

### Pathology

The tumour is usually a papillary adenocarcinoma situated in the middle or outer third of the tube (Fig. 31.1). It is bilateral in 5-10 per cent of cases and, when it is, growth is usually found in the uterus as well and may well be the primary (*see above*).



**Fig. 31.1:** A specimen showing bilateral adenocarcinomas of the fallopian tubes. The left tube is cut open to show the coarse papillomatous nature of the growth

The tube walls are so thin that they are rapidly invaded and the growth encroaches on the peritoneal cavity either directly or by sprouting through the abdominal ostium. The latter, however, is often closed so a hydrosalpinx is present. The disease also spreads by lymphatics to the para-aortic and pelvic nodes and by seeding. Suburethral vaginal metastases, which are not uncommon, represent venous embolism either directly from the tube or via the uterus.

The prognosis, therefore, is poor and, by the time the diagnosis is made, the situation is often hopeless. Indeed, almost the only cases cured are those in which the cancer is found accidentally at operation while it is still in an asymptomatic stage.

The finding of tuberculosis and cancer in the same tube has led to a suggestion that they might have a cause and effect relationship but it is now accepted that any association is fortuitous. The hyperplastic tubal epithelium not infrequently seen in tuberculosis can, incidentally, be misdiagnosed as carcinoma.

### Clinical Features

The patient is commonly aged 50-60 years and, even if married, is nulliparous in 40-50 per cent of cases. She may previously have had salpingitis and this, by obstructing the easy spread of the growth along the tube, can improve the outlook.

The similarities in the age group, association with low parity, and frequent infertility status, suggest that the aetiology may be similar to ovarian carcinoma. Indeed, studies have demonstrated similar genetic abnormalities as in ovarian cancer, as well as recent possible association with BRCA 1 and BRCA 2.

Abnormal vaginal bleeding is the most common presenting complaint and it is present in more than 50 per cent of patients. This may be associated with watery vaginal discharge, vague lower abdominal pain, distention, and pressure. Ten per cent of patients with hydros tubae profluentis, a palpable pelvic mass that resolves during examination associated with watery vaginal discharge. More than 50 per cent of patients present with Stage I or Stage II disease, most likely due to its pattern of presentation. Although it has been diagnosed as an incidental finding during pap smear and during CA 125 screening (as part of a randomised control trial). Pap smear and CA 125 cannot be recommended as screening modalities. However, CA 125, being raised in a significant percentage of patients, acts as an



**Table 31.1: Carcinoma of the fallopian tube — Staging**

FIGO		TNM
0	Primary tumour cannot be assessed	TX
	No evidence of primary tumour	T0
	Carcinoma in situ (pre-invasive carcinoma)	Tis
I	Tumour confined to fallopian tubes	T1
IA	Tumour limited to one tube, without penetrating the serosal surface; no ascites	T1a
IB	Tumour limited to both tubes, without penetrating the serosal surface; no ascites	T1b
IC	Tumour limited to one or both tubes, with extension onto/through the tubal serosa; or with positive malignant cells in the ascites or positive peritoneal washings	T1c
II	Tumour involves one or both fallopian tubes with pelvic extension	T2
IIA	Extension and/or metastasis to uterus and/or ovaries	T2a
IIB	Extension to other pelvic organ	T2b
IIC	IIB/C with positive malignant cells in the ascites or positive peritoneal washings	T2c
III	Tumour involves one or both fallopian tubes with peritoneal implants outside the pelvis and/or positive regional lymph nodes	T3 and/or N1
IIIA	Microscopic peritoneal metastasis outside the pelvis	T3a
IIIB	Microscopic peritoneal metastasis outside the pelvis 2 cm or less in greatest dimension	T3b
IIIC	Peritoneal metastasis more than 2 cm in greatest dimension and/or positive regional lymph nodes	T3c and/or N1
IV	Distant metastasis beyond the peritoneal cavity	M1

adjunctive to transvaginal ultrasonography, CT or MRI scan.

Carcinoma of the fallopian tube should be suspected whenever a woman with symptoms of carcinoma of the body of the uterus is curetted with negative results. Its diagnosis by vaginal cytological studies is reported in 10 per cent of cases but is rare. Ultrasound and laparoscopy may be the means of detecting an early tumour (Table 31.3).

Staging is surgical and is similar to that of ovarian cancer (Tables 31.1 and 31.2).

**Treatment**

Retrospective analyses have suggested that advanced stages at presentation and the presence of residual tumour at the end of treatment with chemotherapy are associated with poorer prognosis. Therefore carefully surgical staging at presentation is paramount in the treatment of early Fallopian cancer. The para-aortic nodes above the inferior mesenteric artery are the most frequently involved retroperitoneal nodes. For advanced disease, there should also be optimal removal of the primary tumour and involved adjacent organs. The following must be performed through a midline incision:

- Careful evaluation of the entire abdomino-pelvic cavity to delineate extent of disease.

**Table 31.2: Carcinoma of the Fallopian tube — Stage grouping**

FIGO stage	UICC		
	T	N	M
IA	T1a	N0	M0
IB	T1b	N0	M0
IC	T1c	N0	M0
IIA	T2a	N0	M0
IIB	T2b	N0	M0
IIC	T2c	N0	M0
IIIA	T3a	N0	M0
IIIB	T3b	N0	M0
IIIC	T3c	N0	M0
	Any T	N1	M0
IV	Any T	Any N	M1

**Table 31.3: Diagnosis criteria**

Pathologic criteria for primary fallopian tube malignancy	
1.	The tumour arises from the endosalpinx
2.	The histologic pattern reproduces the epithelium of tubal mucosa
3.	There is transition from benign to malignant epithelium
4.	The ovary and endometrium are either normal or with a tumour smaller than the tumour in the tube

- Total abdominal hysterectomy and bilateral salpingo-oophorectomy.
- Sampling of the pelvic and para-aortic lymph nodes.
- Infracolic omentectomy.
- Washing of the peritoneal cavity.
- Biopsies of any suspicious areas including the abdominal and pelvic peritoneum.

If the tumour is apparently completely removed surgically, it is wise to give chemotherapy prophylactically thereafter. Combined chemotherapy regimens are used as for ovarian carcinoma.

The success of the paclitaxel and platinum combination in ovarian cancer has led to greater usage of this combination in fallopian cancer.

The 5-year survival rate is approximately 40 per cent of all cases. The very early ones (Stage I) discovered accidentally will have a survival rate of about 65 per cent.

### Follow-up

The objectives of follow-up are as follows:

- Determination of the patient's immediate response to the treatment employed;
- Early recognition and prompt management of any treatment-related complications, including any psychological sequelae;
- Early detection of persistent or recurrent disease;
- Collection of data regarding the efficacy of treatment;
- For patients with early disease, it serves as an opportunity for breast cancer screening, and for patients treated with conservative surgery, for cervical cancer screening.

In general, during the first year following treatment, patients should be seen every three months with a gradual increase in intervals to every four to six months and annually after the fifth year. At each follow-up, the patient should have her history retaken and complete physical examination (including breast, pelvic and rectal examination) performed to exclude any clinical signs of recurrence. The serum CA 125 titre may also be checked at regular intervals, especially if it was raised at primary diagnosis, although the literature in this area is unclear as to the impact of such a practice on survival. Radiological tests such as ultrasonography of the pelvis, CT scans or MRI scans should only be performed when the clinical findings or the tumour markers suggest possible recurrence.

Cysts of the Broad Ligament and Associated Structures	521
Neoplasms of the Pelvic Ligaments and Connective Tissues	523
Neoplasms of the Peritoneum	523

## CYSTS OF THE BROAD LIGAMENT AND ASSOCIATED STRUCTURES

### Pathology

Some broad ligament cysts are really ovarian cysts which, during growth, open up the leaves of the mesovarium and then bulge more and more into the broad ligament to become retroperitoneal tumours.

Primary cysts of the broad ligament arise by distension of one or other part of the rudimentary wolffian system, or by neoplasia in these structures.

#### *Gärtner's Duct*

Gärtner's duct cysts are small, sometimes multiple, and occur at any point on the line of the duct. In the broad ligament they are of little practical importance. Some authorities consider the hydatid of Morgagni to be the dilated outer end of the duct.

#### *Kobelt's Tubules*

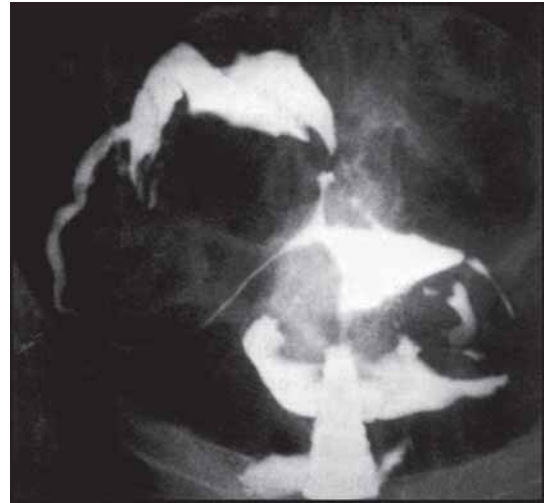
Cysts of these are also small and merely of academic interest. They lie on the posterior aspect of the outer part of the broad ligament. Very rarely a moderate-sized bunch of innumerable tiny cysts is found in this area and probably represents a benign neoplastic change (Fig. 32.1).

#### *Epoophoron and Paroophoron*

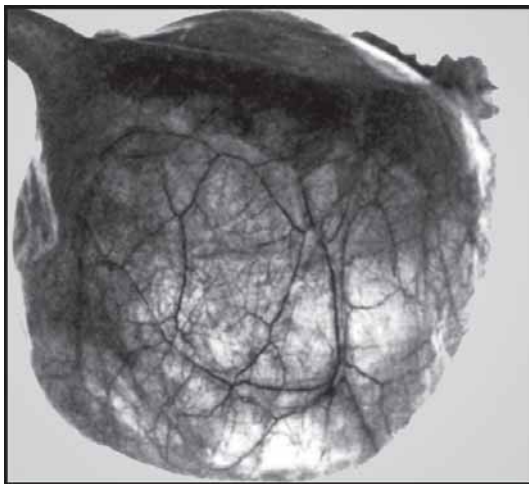
The common and typical broad ligament cyst arises from one of these structures, usually the epoophoron (parovarium). It is sited near the attachment of the mesovarium and, as it grows, separates the ovary from the fallopian tube, stretching the tube and the fimbriae over its upper pole (Figs 32.2 and 32.3). Such cysts are variously termed *parovarian* or *fimbrial* although they certainly do not arise from the fimbria. Although usually smaller than ovarian cysts, they can attain a very large size, filling the whole abdominal cavity. In such a case the lesion probably represents benign neoplasia rather than distension. Indeed, some parovarian cysts develop intracystic papillae and this has led to a suggestion that they can arise from misplaced ovarian tissue.



**Fig. 32.1:** A multicystic structure growing from the anterior leaf of the outer part of the broad ligament and immediately below the tube. It is probably arising from Kobelt's tubules



**Fig. 32.3:** Salpingography in the case of parovarian cyst. The right tube is stretched out over and around the tumour



**Fig. 32.2:** A parovarian (sometimes called fimbrial) cyst with the tube stretched over its upper pole. The presence of vessels crossing each other in the capsule tells the surgeon that the tumour may be extraperitoneal. The vessels belong to the peritoneum and to the true capsule of the cyst, so the cyst is easily shelled out of its peritoneal coat

The parovarian cyst is nearly always unilocular and thin-walled; it contains a watery colourless fluid in which cholesterol crystals can be found.

The lining epithelium is usually a single layer of flat or cuboidal cells, some of which may be ciliated. Indeed, the histological appearance is similar to that of a serous cystadenoma of the ovary and for this reason it has been suggested that the cyst arises from Walthard's cells. The wall of a parovarian cyst frequently contains smooth

muscle and this helps to distinguish it from an ovarian cyst on microscopy.

At operation the cyst is found to have two coverings, the peritoneum of the broad ligament being closely applied to the cyst wall proper. The sight of blood vessels crossing each other tells the surgeon immediately that he or she is dealing with an extraperitoneal tumour (Fig. 32.2). Its extraperitoneal site raises important anatomical considerations. The lower pole of the cyst may remain in the pelvis and displace the uterus to one side. If it does, it also comes into close relation with the ureter which is pushed outwards.

In theory a parovarian cyst, especially one with papillae, may become malignant. In practice, this rarely, if ever, occurs.

### Complications

These are the same as for ovarian cysts. Pregnancy complicating parovarian cysts is considered.

### Clinical Features

Broad ligament cysts tend to arise at a rather younger age than do ovarian cysts but otherwise the symptoms and signs are similar. It may therefore be impossible to distinguish between the two types but *a broad ligament origin should be suspected whenever a cyst is fixed in the pelvis and especially when it displaces the uterus laterally*. The close proximity of the tumour to the uterus sometimes suggests that it is uterine in origin. Confusion can arise over a soft leiomyoma, uterine or broad ligament in site, and over a pelvic kidney.

## Treatment

Operative treatment is indicated in nearly all cases and consists of shelling out the cyst from its extraperitoneal bed. If the lower pole is deep in the pelvis, the ureter is at risk during this process. Laparoscopic treatment is often feasible.

## NEOPLASMS OF THE PELVIC LIGAMENTS AND CONNECTIVE TISSUES

Extensions of growths arising in the bladder, uterus, cervix, vagina, ovary and bowel are extremely common, and have already been covered. Leaving these aside, and also broad ligament cysts, some of which are undoubtedly neoplastic (*see above*), primary tumours of the pelvic ligaments include the leiomyoma, fibroma, teratoma and various sarcomas. Only the first of these deserves description.

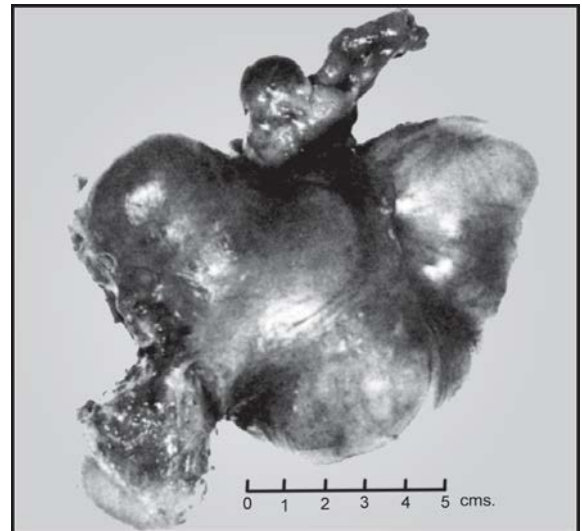
*Leiomyomas* are not uncommon in the round, ovarian and broad ligaments. They are often found in association with similar uterine tumours and their pathology and complications are the same.

*Broad ligament leiomyomas are of two types:* Either a uterine tumour (usually cervical) which grows into the broad ligament (false broad ligament tumour) but preserves a uterine attachment (Fig. 32.4) or a primary (true) broad ligament leiomyoma arising from the subperitoneal connective tissue of the ligament.

It is the anatomy of these tumours which makes them important clinically. They are extraperitoneal and therefore remain fixed in the pelvis, displacing the uterus to one side. The true broad ligament tumour may lie lateral to the ureter but the false broad ligament tumour is always medial to it. This is important in estimating the course of the ureter during surgery. In pregnancy, broad ligament leiomyomas are likely to obstruct labour and to cause retention of urine. In the non-pregnant state, they may cause hydronephrosis. The symptoms they cause are those resulting from pressure on adjacent organs, or the patient may notice a lower abdominal tumour. Their removal can be difficult and hazardous chiefly because of the risk to the ureter.

## NEOPLASMS OF THE PERITONEUM

The peritoneum is commonly involved in the advanced stages of malignancies of abdominal and pelvic organs. Primary tumours are rarely seen.



**Fig. 32.4:** A broad ligament leiomyoma growing from the right wall of the uterus, elevating the tube and ovary and displacing the cervix to the left

## Peritoneal Carcinomas

Primary peritoneal carcinoma simulates ovarian cancer in its clinical features, and is seen especially in women who have previously undergone hysterectomy and bilateral salpingo-oophorectomy.

At laparotomy, extensive disease is seen in the upper abdomen, particularly in the omentum. Microscopic or small macroscopic cancer deposits are seen on the surface of the ovaries, but more extensive involvement of the uterosacral ligaments, pelvic peritoneum or omentum is seen.

Histologically, peritoneal serous carcinomas resemble moderately to poorly differentiated serous ovarian carcinoma. Primary peritoneal endometrioid carcinoma is less common.

Treatment is by chemotherapy and/or radiotherapy with intraperitoneal radioisotopes and external beam therapy.

## Mesotheliomas

Peritoneal malignant mesotheliomas are uncommon tumours. They may be fibrosarcomatous, papillary-alveolar, carcinomatous or mixed. They can also develop after hysterectomy and bilateral salpingo-oophorectomy for benign disease. Grossly, they appear as multiple masses intraperitoneally. The differential diagnosis is from ovarian tumour implants and primary peritoneal müllerian neoplasms.

# CHAPTER 33

## Tumours of the Ovary

Ovarian Enlargements	524	Meig's syndrome	543
Distension or Retention Cysts	524	Cryoreductive Surgery	553
Ovarian Neoplasms	528	Ovarian and Parovarian Tumours	
Germ Cell Tumours	538	and Pregnancy	559

### OVARIAN ENLARGEMENTS

The causes of enlargement of the ovary are:

- Hypertrophy—Congenital and acquired hypertrophies are described but rarely seen.
- Corpus luteum haematoma
- Ovarian pregnancy
- Oophoritis
  - Acute
  - Chronic

The enlargement is in part the result of adhesions to surrounding organs and tissues.

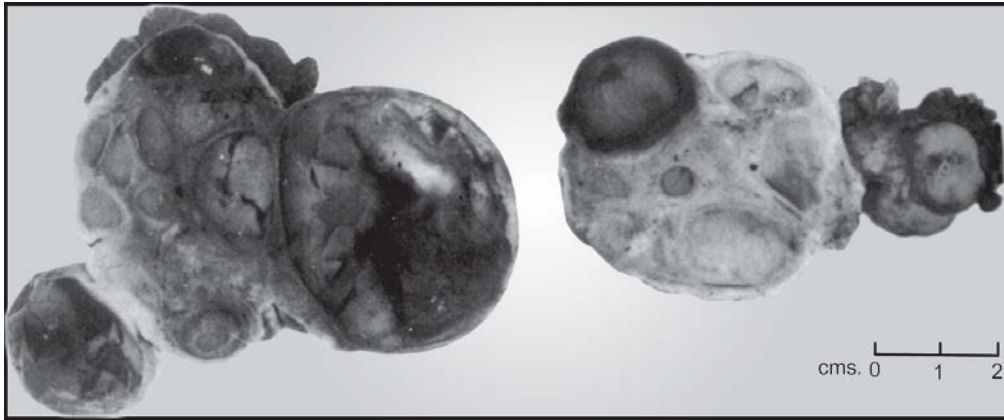
- Endometriosis
- Lutein cysts and luteoma of pregnancy
- Distension or retention cysts, with or without intracystic haemorrhage
- Primary ovarian neoplasms
  - Benign
  - Malignant
- Secondary (metastatic) neoplasms.

This chapter is concerned with the last three groups.

### DISTENSION OR RETENTION CYSTS

Cystic enlargement of one or other of the normal ovarian structures is so common as to be regarded as physiological. The senile ovary is usually free but it is rare to see the ovary of a child or adult woman without at least one small cyst in it. The mere finding of cysts in an ovary should not therefore be regarded as being of pathological significance. Failure of surgeons to recognise this fundamental fact has led to many young women having a normal ovary removed in the course of appendicectomy. Many more ovaries have been sacrificed for possessing a normal corpus luteum.

When cystic change proceeds beyond the normal range, the condition is referred to as a cystic ovary; this represents a disturbance of function only, whereas an *ovarian*



**Fig. 33.1:** Cystic ovaries with haemorrhage into some of the cysts

*cyst* may be a neoplasm. Distension cysts are of several types and any of them can become complicated by intracystic haemorrhage; this ultimately results in serosanguinous contents to cause confusion with endometriosis (Fig. 33.1).

### Types

#### *Atretic Cysts*

The graafian follicle itself or any of its products such as the corpus luteum, corpus albicans and corpus fibrosum, may remain cystic for some time prior to their ultimate replacement by fibrous tissue. The cysts are usually small and multiple and may be lined by granulosa cells, granulosa lutein cells, theca lutein cells, connective tissue or hyaline tissue. They are normally found in small numbers at all ages before the menopause; they have no pathological significance and are symptomless.

#### Germinal Inclusion Cysts; Walthard Inclusions

These are microscopic cysts, occasionally found in the ovaries of older women, and appear to be lined by epithelium similar to that found on the surface of the ovary which is coelomic in origin. They are discovered on histological examination and their only importance is that they may be the origin of cystadenomas and of Brenner tumours.

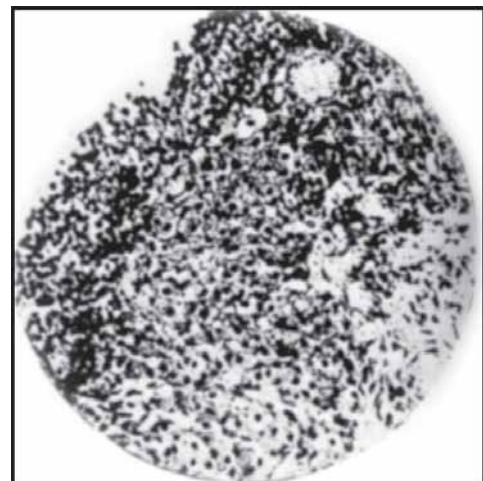
#### Follicular and Theca Lutein Cysts

##### *Pathology*

Follicular cysts possibly represent enlargements of unruptured graafian follicles. The ovum degenerates and

disappears but the granulosa and theca cell lining persist and remain functional for a variable time (Fig. 33.2). As more follicular fluid is produced, the follicle increases in size and its lining epithelium may ultimately become flattened or disappear. These cysts can be single or multiple. In the latter case they commonly affect both ovaries equally. They are always small and, even when they occur singly, usually have a diameter of up to 3-5 cm, and rarely more than 8 cm.

The cells lining the cysts vary in type. Either granulosa or theca cells may predominate. Occasionally, and despite the fact that ovulation has not occurred, one or both layers show evidence of luteinisation. The functional activity of the cysts is variable. Often it is insignificant and does not interfere with normal ovulation occurring in another graafian follicle. This is particularly true when the



**Fig. 33.2:** The wall of a follicular cyst lined by granulosa cells with theca lutein cells outside

condition is the result of an excessive but otherwise normal gonadotrophic stimulus. In other cases, and presumably when the gonadotrophic stimulus is abnormal, ovulation is arrested for shorter or longer periods and the tissues in and around the cyst wall can be predominantly oestrogenic, progestogenic or androgenic.

The single follicular cyst with granulosa cells predominant is associated with the production mainly of oestrogen. The polycystic ovaries which are found in the polycystic ovary syndrome produce relatively excessive amounts of androgens.

Theca lutein cysts are less common than follicular and corpus luteum cysts. They are usually bilateral, multicystic and larger in size, up to 25 cm. Even when cysts are not present in these conditions, there may be multiple solid foci of luteal tissue. In all cases the excessive luteinisation is the result of the high output of gonadotrophins. They are associated with molar pregnancy, choriocarcinoma, multiple pregnancy and are also seen following ovulation induction with clomiphene citrate or gonadotrophins. No treatment is required for these cysts. The abnormal luteal tissue disappears spontaneously when the cause is removed.

#### *Chronic Hyperaemia*

Active or passive congestion of the ovaries as is caused by pelvic infection is the commonest cause of cystic change. Its role has been clearly demonstrated experimentally in animals and its effect is to increase and hasten follicular activity. It would appear that many follicles are stimulated to activity; only one ruptures but the others become cystic.

#### *An Excessive Gonadotrophin Stimulus*

An abnormally strong gonadotrophic stimulus, whether endogenous or exogenous, causes follicular and theca lutein cysts. This is convincingly proved by the effect of overdosage with gonadotrophins, especially human chorionic gonadotrophin (hCG) administered for therapeutic purposes, or endogenous hCG produced by pituitary tumours, molar pregnancy and multiple gestation. The follicular cysts found in the ovaries of newborn babies are the result of their intrauterine stimulation by placental gonadotrophins.

#### *An Abnormal Gonadotrophic Stimulus*

An abnormal gonadotrophin stimulus can arise as a result of disease in the hypothalamus and pituitary or be

idiopathic. It is the probable basis for the single follicular cyst producing oestrogens which is found in dysfunctional uterine bleeding and for the multiple theca lutein cysts of the polycystic ovary syndrome, and is associated with anovulation.

### Symptoms

*The majority of cystic ovaries are symptomless* and are discovered incidentally at operation or during pelvic examination. Any symptoms which are produced depend on their hormone activity and vary as follows.

### Menstrual Disturbance

*Polymenorrhoea or polymenorrhagia:* These are mostly seen when multiple small cysts are associated with conditions causing ovarian hyperaemia (*see above*). Ovulation continues despite the cysts.

*Amenorrhoea:* Amenorrhoea or oligomenorrhoea results when cystic ovaries are androgenic. Short periods of amenorrhoea may also occur when they produce oestrogens or progestogens continuously.

*Infertility:* When cystic change is associated with suppression of ovulation, infertility of long or short duration is inevitable.

*Pair:* It is often stated that a cystic ovary causes pain in the iliac fossa. Women with such a pain sometimes have a cystic ovary as well but, in the absence of associated disease, removal of such an ovary never relieves the pain for more than a few months, any fleeting good effect being psychological. Indeed, a cystic ovary does not cause pain unless haemorrhage occurs, or unless it is involved in pelvic adhesions.

Conditions causing tension within a testis give rise to severe discomfort but distension of the ovary never does. This is because its tunica albuginea is ill-formed and non-resistant. It is also doubtful whether haemorrhage into a cyst or into a corpus luteum ever produces pain; this only arises when the blood leaks from the haematoma into the peritoneum. This concept also explains why the normal physiological cycle, characterised by rapid distension of a follicle and growth of a corpus luteum, is a painless process.

If a cystic ovary is buried in peritoneal adhesions, these may offer the necessary resistance to distension, and pain can certainly result.



## Treatment

If cystic ovaries are associated with pelvic inflammatory or other disease, treatment is directed to the latter.

In the absence of gross pelvic disease the treatment of cystic ovaries is governed by the fact that they tend to be self-curative. If left alone the cysts become inactive and disappear; any temporary menstrual disturbance can meanwhile be treated symptomatically. Symptomless cysts should certainly be left alone although, if found incidentally at laparotomy, they may be punctured. Sometimes a single follicular cyst collapses from pressure during bimanual examination. This need never induce worry; it does not cause symptoms and may relieve any that were present.

Surgical removal of the cystic portion of an ovary, or of a whole ovary, is usually followed by cyst formation in the remaining ovarian tissue. The more ovarian tissue removed, the more likely the remainder is to become cystic. This is possibly because the underlying cause of disease, hormonal or vascular, persists and becomes concentrated on a smaller target.

Ovarian wedge resection of bilateral polycystic ovaries associated with the polycystic ovary syndrome has now been replaced by laparoscopic ovarian drilling. This should only be resorted to when medical methods fail as it can result in adhesion formation and other complications.

## Corpus Luteum Cysts

A normal corpus luteum is considered cystic if greater than 3 cm in diameter – this is especially seen following the occurrence of haemorrhage into its cavity. The corpus luteum of pregnancy frequently forms quite a large cyst as it degenerates between the second and third months; it may then be mistaken for an ovarian neoplasm and be unnecessarily treated by surgery (Fig. 33.3). These conditions are symptomless and disappear of their own accord.

Sometimes the corpus luteum of menstruation not only becomes cystic but its lining of granulosa lutein and para lutein cells continues to produce progesterone and oestradiol for a longer time than normal.

These cysts are to be regarded as manifestations of temporary derangements in the pituitary-ovarian cycle which cure themselves. Meanwhile, however, they occasionally cause short periods of amenorrhoea followed by prolonged uterine bleeding to produce a

clinical picture simulating that of early pregnancy, abortion or even ectopic pregnancy. The endometrium is in the secretory phase, and the excretion of pregnanediol is increased.

Corpus luteum cysts do not ordinarily require active treatment and only in exceptional circumstances do they have to be excised. Occasionally a corpus luteum may become greater than 3 cm diameter when it is called a corpus luteum cyst. Such cysts can present with delayed menstruation, pain and an adnexal mass and be mistaken for an ectopic pregnancy. If they rupture, the patient presents with haemoperitoneum and may require surgical management.

## Luteoma Of Pregnancy

Solid multiple foci of luteal tissue are sometimes found in one or both ovaries during pregnancy, either intrauterine or extrauterine. Luteomas represent hyperplastic conditions rather than true neoplasms. These are separate from the corpus luteum of pregnancy and vary in diameter from 8 to 20 cm. Their cut surface is orange yellow to greyish yellow in colour.

These tumours do not ordinarily give rise to symptoms, and most have been discovered accidentally at caesarean section or during laparotomy in the early puerperium. Since the ovaries are rarely inspected closely during pregnancy, luteomas may be more common than is realised. They probably arise from theca or stroma cells under the influence of chorionic gonadotrophin and disappear spontaneously after pregnancy.



**Fig. 33.3:** A corpus luteum cyst in the process of enucleation. The crenated solid portion of the corpus luteum is visible on the side wall of the cyst. A light bowel clamp has been applied across the mesovarium for haemostasis

Although usually symptomless, luteomas of pregnancy occasionally have an androgenic function, as evidenced not only by hormone assays but by the occurrence of minor degrees of virilisation of the mother or of her female child.

## OVARIAN NEOPLASMS

It is important to have an internationally agreed classification of ovarian tumours in order to allow a proper analysis of the trends in their incidence and for proper and meaningful comparisons of treatment.

The pathology of ovarian neoplasms is one of the most complex areas of gynaecology, because the ovary gives rise to a greater range and variety of tumours than does any other organ. While in other organs the tissue of origin is usually fairly clear, the tumour from which an ovarian tumour arises is often uncertain and the mode of development of the presumptive tissue is often disputed. Many classification schemes have been proposed — some based on various tumour characteristics, others on clinical features such as functioning tumours or the malignant potential or behaviour. None is really satisfactory, for ovaries consist of sex cells which are totipotent and of mesenchymal cells which are multipotent, so when the ovary becomes neoplastic almost any sort of tumour can result. Certainly ovarian tumours are characterised by an extraordinary and bewildering variety of histological patterns and grades of malignancy.

For the purposes of comparing results obtained in different centres, a pathological classification of ovarian tumours benign, borderline and malignant, primary and secondary is recognised by the International Federation of Gynaecology and Obstetrics (FIGO) and the World Health Organisation (WHO). This is based on the histological cell of origin and no account is taken of the gross characteristics or functional activity. The full classification is complex and is split into nine main groups (Table 33.1).

### Primary Ovarian Tumours

#### Overview

The WHO classification of ovarian tumours is detailed in Table 33.1 but as it is complex some general comments are justified regarding the main types. About 70 to 80 per cent of primary ovarian tumours are of epithelial origin, 10 per cent of stromal origin and 5 per cent of

germ cell origin, while the remainder fall into the other groups.

*Epithelial tumours* can be split into five basic histological groups which resemble normal epithelia present in the genitourinary tract, even though the clinical behaviour of all groups is indistinguishable. Serous tumours appear similar to the epithelium of the fallopian tube, mucinous tumours similar to the endocervical mucosa, and endometrial tumours similar to the endometrium, while Brenner tumours contain cells suggestive of the transitional epithelium of the bladder. Many of the tumours actually present a mixed histological appearance to include several of the epithelial tumour types. For example, tumours with mixtures of serous and endometrioid histological features are quite common but their clinical behaviour is not significantly different from either of the pure types.

*Borderline epithelial* ovarian tumours, are tumours of low malignant potential which are seen in younger premenopausal women between the ages of 30 and 50 years. Borderline tumours remain confined to the ovary for a longer time, but they also metastasise. Metastases may be non-invasive or invasive. Sometimes metastases occur as a late event and patients may die from borderline tumours some 10-30 years after the original operation.

Serous and mucinous cystadenocarcinoma are the most common types of invasive epithelial ovarian cancers but again are frequently mixed tumours. They comprise 60 per cent of all primary tumours of the ovary and 9 per cent of those that are malignant. The ratio of serous to mucinous cystadenocarcinoma varies between 4:1 and 10:1 in different parts of the world. They may also contain tissue of the endometrioid variety, although endometrioid carcinomas can be distinguished separately (2% of ovarian tumours). Malignant Brenner tumours are extremely rare. Clear cell ovarian tumours have also been referred to as mesonephric tumours of which the borderline and benign variety are uncommon. They are highly malignant tumours and two histological patterns are recognised: the solid clear cell pattern and the hobnail pattern. Clear cell carcinomas have often been described in association with endometriosis, as have the endometrioid carcinomas.

*Sex cord stromal tumours* are composed of sex cords and stroma of either male or female origin and occur in all age groups. They include those containing granulosa,

Table 33.1: Classification of ovarian tumours

- I. Epithelial tumours
  - A. Serous tumours
    - 1. Benign
      - a. Cystadenoma and papillary cystadenoma
      - b. Surface papilloma
      - c. Adenofibroma and cystadenofibroma
    - 2. Borderline malignant (carcinomas of low malignant potential)
      - a. Cystadenoma and papillary cystadenoma
      - b. Surface papilloma
      - c. Adenofibroma and cystadenofibroma
    - 3. Malignant
      - a. Adenocarcinoma, papillary adenocarcinoma
      - b. Surface papillary carcinoma
      - c. Malignant adenofibroma and cystadenofibroma
  - B. Mucinous tumours
    - 1. Benign
      - a. Cystadenoma and papillary cystadenoma
      - b. Surface papilloma
      - c. Adenofibroma and cystadenofibroma
    - 2. Borderline and papillary cystadenoma
      - a. Cystadenoma and papillary cystadenoma
      - b. Surface papilloma
      - c. Adenofibroma and cystadenofibroma
    - 3. Malignant
      - a. Adenocarcinoma and cystadenocarcinoma
      - b. Malignant adenofibroma and cystadenofibroma
  - C. Endometrioid tumours
    - 1. Benign
      - a. Adenoma and cystadenoma
      - b. Adenofibroma and cystadenofibroma
    - 2. Borderline malignant
      - a. Adenoma and cystadenoma
      - b. Adenofibroma and cystadenofibroma
    - 3. Malignant
      - a. Carcinoma
        - i. Adenocarcinoma
        - ii. Adenoacanthoma
        - iii. Malignant adenofibroma and cystadenofibroma
      - b. Endometrioid stromal sarcomas
      - c. Mixed müllerian mesodermal tumours, homologous and heterologous
  - D. Clear cell (mesonephroid) tumours
    - 1. Benign: adenofibroma
    - 2. Borderline malignant
    - 3. Malignant: carcinoma and adenocarcinoma
  - E. Brenner tumours
    - 1. Benign
    - 2. Borderline malignant
    - 3. Malignant
  - F. Mixed epithelial tumour
    - 1. Benign
    - 2. Borderline malignant
    - 3. Malignant
  - G. Undifferentiated carcinoma
  - H. Unclassified epithelial tumours.
- II. Sex cord stromal tumours
  - A. Granulosa cell tumours
    - 1. Granulosa cell tumours
    - 2. Tumours in the thecoma-fibroma group
      - a. Thecoma
      - b. Fibroma
      - c. Unclassified
  - B. Androblastomas : Sertoli-Leydig cell tumours
    - 1. Well differentiated
      - a. Tubular androblastoma and Sertoli cell tumour (tubular adenoma of Pick)
      - b. Tubular androblastoma with lipid storage and Sertoli cell tumour with lipid storage (folliculome lipidique of Lecene)
      - c. Sertoli-Leydig cell tumour (tubular adenoma with Leydig cells)
      - d. Leydig cell tumour and hilus cell tumour.
    - 2. Of intermediate differentiation
    - 3. Poorly differentiated (sarcomatoid)
    - 4. With heterologous elements
  - C. Gynandroblastoma
  - D. Unclassified
- III. Lipoid (lipid) cell tumours
- IV. Germ cell tumours
  - A. Dysgerminoma
  - B. Endodermal sinus tumour
  - C. Embryonal carcinoma
  - D. Polyembryoma
  - E. Choriocarcinoma
  - F. Teratomas
    - 1. Immature
    - 2. Mature
      - a. Solid
      - b. Cystic
        - i. Dermoid cyst (mature cystic teratoma)
        - ii. Dermoid cyst with malignant transformation.
    - 3. Monodermal and highly specialised
      - a. Struma ovarii
      - b. Carcinoid
      - c. Struma ovarii and carcinoid
      - d. Others
  - G. Mixed forms
- V. Gonadoblastoma
  - A. Pure
  - B. Mixed with dysgerminoma or other form of germ cell tumour
- VI. Soft tissue tumours not specific to the ovary.
- VII. Unclassified tumours
- VIII. Secondary (metastatic) tumours
- IX. Tumour-like conditions.

theca, Sertoli or Leydig cells and collectively account for about 5 per cent of all ovarian tumours. This tumour group has also been referred to as the functioning tumour group because many exhibit sex steroid activity. The demonstration of clinical hormonal activity by an ovarian tumour does not necessarily indicate that the tumour is of sex cord or stromal origin because many metastatic tumours interact with the ovarian tissue to result in a significant hormonal production. Hormonal activity does not reflect the likely clinical outcome but it may be useful as a tumour marker.

Each member of the sex cord stromal tumours is capable of synthesising any of the sex steroids and there is no characteristic hormonal product for any specific member of this group. Granulosa cell tumours may produce androgens and tumours of male sex cord origin may produce oestrogen.

Granulosa cell tumours form the vast majority of the sex cord stromal tumours. Only the granulosa cell tumour may become malignant. There is often difficulty in distinguishing thecomas from the hormonally inactive fibromas on histological grounds. The male counterpart of sex cord tumours is the androblastoma (formerly known as arrhenoblastoma) which is of low-grade malignancy.

Tumours of male gonadal stroma include the various forms of the *lipoid cell tumours*, the Leydig cell tumours, the hilus cell tumours, and possibly the adrenal rest tumours and therefore they are often diagnosed early and malignancy is rarely seen.

*Germ cell tumours* generally occur prior to puberty or in early adult life. The germ cell tumours, which include many types including teratomas and dysgerminomas, account for about 15 per cent of all ovarian tumours at all ages; however, they account for 60-70 per cent of tumours in women under the age of 20 and about 90 per cent of those which occur before puberty. They represent the malignant transformation of primordial germ cells at varying stages of differentiation with the exception of the benign mature teratoma (dermoid cyst). The mature teratoma is the commonest ovarian germ cell tumour and is composed of well-differentiated adult tissue types with little tendency to malignant change. The immature teratoma is composed of a variety of tissues, including immature mesenchymal or foetal neural elements. Germ cell tumours, usually dysgerminomas, occur in at least a quarter of those individuals whose intra-abdominal gonads bear Y chromosomes.

At least half of all dysgerminomas are said to arise in dysgenetic gonads. Although germ cell tumours are generally unilateral it is important to remember that about 10 to 15 per cent of dysgerminomas are bilateral. The endodermal sinus germ cell tumour is a highly malignant tumour. Other tumours in this group of tumours are rare.

*Gonadoblastomas* are common and occur in patients with either a pure or mixed gonadal dysgenesis and the gonad in which they arise is almost invariably a streak or an immature or atrophic testis.

Approximately 80 per cent of primary ovarian tumours are mainly cystic and are loosely called *ovarian cysts*. Some types can reach huge dimensions but mammoth tumours are now less common because of the availability of ultrasound and surgery. Even so, cysts somewhat larger than a full-time pregnancy are seen (Fig. 33.4).

Most tumours grow in the substance of the ovary and are covered by a capsule of thinned-out ovarian tissue. Ordinarily they expand into the peritoneal cavity but occasionally they extend into the mesovarium and, by opening up its leaves, ultimately lie extraperitoneally between the layers of the broad ligament. This development makes their removal more hazardous.

All ovarian tumours, solid or cystic, show a strong tendency to have a bilateral distribution – even when they are benign.

Approximately 45 per cent of tumours removed from patients aged 45 years and over are malignant in part or whole.



**Fig. 33.4:** A large ovarian cyst in a woman aged 74 years. This had been known to be present for at least 20 years but the patient refused operation until the size of the tumour prevented her walking. It was removed under local anaesthesia, the cyst being tapped to permit only a small incision being used. The tumour proved to be a cystadenoma containing more than 38 litres of fluid

Malignant ovarian tumours are disseminated as follows:

- By seeding of cancer cells to the peritoneum, omentum, tubes and uterus
- By lymphatics to the paraortic nodes, umbilicus and diaphragm
- By the bloodstream to the lower vagina and, in the case of sarcomas and teratomas, to the lungs and elsewhere
- By direct spread to any neighbouring organ or tissue.

The prognosis in cases of malignant tumours depends on the histological type, the degree of differentiation and the clinical stage when diagnosed. With regard to the type of tumour, the granulosa cell tumour has the best prognosis because it tends to grow slowly and recurrence is infrequent or delayed for many years. Of the common epithelial type, which forms the majority of the malignant tumours, the mucinous and endometrioid tend to present early and therefore have a better prognosis than serous cystadenocarcinoma which presents late. The worst prognosis is for women who have unclassified undifferentiated solid carcinomas or adenocarcinomas.

## Pathology

### *Epithelial Ovarian Tumours*

*Benign serous tumours:* Serous tumours account for 20 per cent of benign ovarian neoplasms and are the second commonest in this category, the commonest being the benign cystic teratoma.

These may be cystic, papillary or adenofibromatous on macroscopic appearance and each type may occur singly or in combination. The serous cystadenoma occurs as a thin-walled, often translucent cyst, which is usually unilocular but which may have a few daughter cysts in the wall. The cyst may vary in size from 20 to 30 cm in diameter and, while often unilateral, can be bilateral. The papillary serous cystadenoma can occur in combination with a cyst and the papillae on the inner wall or on the outer surface (exophytic). The exophytic tumours are often associated with ascites and there may be implantation of fragments of tumour on the peritoneal surfaces, thus giving a false impression of malignancy at operation. Five to ten per cent have borderline malignant potential. The serous adenofibroma occurs as a lobulated, hard knobbly solid mass which occurs alone but is more often associated

with a serous cyst when it forms a fibrous thickening or nodule in the cyst wall. The serous adenofibroma is essentially a fibrous neoplasm.

Histologically, serous cystadenomas are lined by a single layer of flattened or cuboidal cells but in places the cells may be more columnar and resemble those lining the fallopian tubes. The tubal nature of the epithelium is particularly evident over the papillae. Psammoma bodies may be seen in the stroma of these tumours, but they are not a specific diagnostic feature and are not indicative of malignancy. These are areas of fine calcific granulation dispersed throughout the tumour which may be seen on X-ray.

*Malignant Serous Tumours:* Up to one-fourth of serous tumours are malignant. They account for 75 per cent of epithelial cancers. Serous adenocarcinomas are usually fairly large and in over half of the cases both ovaries are involved. About a quarter of these carcinomas are primary cystic and about two-thirds are semi-solid, with only a small proportion being solid. The tumour may be adherent to the bowel, the pelvic organs or pelvic wall and the peritoneum may be studded with widespread deposits, especially if papillae are present on the outer surface of the tumour. On section, areas of haemorrhage and necrosis are frequently seen and the fluid in a cystic portion of the tumour is often bloodstained. Gross examination may not suffice to distinguish between benign, borderline and malignant tumours and frozen section may be required to make the diagnosis.

Histologically, the tumours show a wide variety of patterns but papillary, adenopapillary or diffuse patterns are the principal types noted in well-differentiated tumours. Most tumours have a mixed pattern of differentiation and it can be difficult to diagnose the precise type of tumour.

### *Mucinous Cystadenoma*

These are also common and account for up to 20 per cent of all ovarian tumours. In approximately 10 per cent of cases the tumour is bilateral. They may attain a very large size and may be multilocular. The growing point of the cyst is marked by a mass of small locules (Fig. 33.5) and some of the large locules may result from a breakdown of partitions. Intracystic papillae, if present, are small and few and the inner walls are generally smooth. The outer wall varies in thickness and is white, grey or silvery blue



**Fig. 33.5:** An ovarian mucinous cystadenoma of moderate size. The more actively growing part consists of innumerable small locules



**Fig. 33.6:** Photomicrograph of a mucinous cystadenoma showing the single layered lining of secretory cells

in colour. Adhesions to adjacent tissues are not present unless there have been degenerative changes in the wall.

The cysts are lined by tall columnar cells and these secrete a mucus material — a glycoprotein with a high content of neutral polysaccharides. The appearance of the epithelium is remarkably like that of the glands of the cervix or of the intestine (Fig. 33.6). The fluid content is thick in consistency and glairy, and is colourless, yellow, green or brown depending on the presence of blood pigments derived from previous intracystic haemorrhages.

A rare complication of an active cyst which ruptures and spills into the peritoneum is pseudomyxoma peritonei, a condition in which the epithelial cells of the tumour invade the omentum, and also spread as a film over the visceral and parietal peritoneum. From these sites they secrete semi-solid mucin into the abdominal cavity and this causes distension, aching, pain and vomiting. Even when the causal tumour is benign and the mucinous material removed, the abdomen tends to refill. In benign tumours this might be due to induction of mucinous metaplasia of the peritoneum.

It is now known that leakage from the parent cyst is not essential for the production of pseudomyxoma peritonei. Moreover, the condition also occurs as a complication of a mucocele or adenocarcinoma of the

appendix or colon and is thus found in men as well as in women. Appendicular diseases and a cystadenoma of the ovary sometimes coexist in these cases.

About 5-10 per cent of mucinous ovarian tumours are malignant, accounting for 20 per cent of epithelial ovarian cancers.

#### *Endometrioid Tumours*

Benign tumours are rare. Endometrioid adenocarcinomas account for 2 per cent of epithelial cancer.

The primary neoplasms of the ovary histologically closely resemble tumours of the uterine endometrium and an endometrioid adenocarcinoma of the ovary has all the microscopic features of an adenocarcinoma of the endometrium. They can develop from either pre-existing ovarian endometriosis or from the surface epithelium of the ovary via a process of müllerian metaplasia along endometrial lines. The proportion of cases that arise from each source is uncertain, but relatively few of the neoplasms which are frequently diagnosed nowadays as being endometrioid in type (up to 30% incidence) would satisfy the criteria which Sampson suggested as being necessary for the proof of a malignant tumour having arisen from a focus of endometriosis. Indeed, in most studies endometriosis has only been found in about 10 per cent of ovaries in which an endometrioid adenocarcinoma was present.

The gross features of these neoplasms are in no way specific. They are generally large and measure between 10 and 25 cm in diameter. The outer surface is usually smooth but there may occasionally be papillary outgrowths. On section the tumours may be solid, partially cystic or wholly cystic, the latter variety usually showing abundant papillary in-growths. The cystic areas can contain clear, mucoid or haemorrhagic fluid.

Histologically these tumours are formed of cuboidal or columnar epithelial cells arranged in a glandular or acinar pattern; a proportion of these neoplasms have a papillary form. The tumour stroma resembles that of the ovary rather than that of the endometrium. The malignant nature of the tumour is usually readily apparent from the cellular atypia, mitotic activity and stromal invasion which are generally found. A number of tumours show remarkably little evidence of frank malignancy and would probably be diagnosed as being of borderline malignancy were a benign form of this neoplasm common. The degree of differentiation varies but a high proportion of these tumours are well differentiated and it is in these that the remarkable similarity to an endometrial adenocarcinoma is apparent.

There are three additional histological features of these tumours: a proportion contain mucinous or serous elements; squamous metaplasia is common, and most endometrioid adenocarcinomas contain areas in which the cells have clear or vacuolated cytoplasm and should not be confused with the mesonephroid adenocarcinoma in which clear cells may also be found.

Because an endometrial adenocarcinoma is found in association with an ovarian endometrioid adenocarcinoma in up to a third of cases, it is sometimes difficult for the pathologist to determine if the tumour in the ovary is primary or secondary from an endometrial carcinoma. The treatment is similar, however, so the clinician has no such problem although the role of chemotherapeutic agents and/or progestational agents is uncertain.

#### *Clear Cell (mesonephroid) Tumours*

Benign tumours are uncommon and the presenting signs and symptoms of the malignant tumours (1 per cent of epithelial cancers) are those of any of the epithelial tumours. Histologically the mesonephroid tumours have to be distinguished from the endodermal sinus tumour, the endometrioid carcinoma, papillary serous cystadenocarcinoma and the lipid cell tumour.

#### *Brenner Tumour*

This tumour consists of columns of squamous or transitional cells with a central core lined by columnar epithelium; these lie in a stroma which occasionally has deposits of calcium. The squamous cell elements are likened to the epithelium of the urinary tract with the suggestion that they may derive from the rete tubules. The columnar cells are likened to those of the endocervix. The histogenesis of the Brenner tumour remains in doubt since none of the theories explains all the characteristic features of the tumour. It is remarkable that the growth is hardly ever found alone and is usually part of a fibroma or incorporated in the wall of a mucinous cystadenoma. Even though it may have a bilateral distribution, the Brenner tumour is nearly always benign and malignant tumours are very uncommon.

Most Brenner tumours are small, even microscopic, and do not give rise to any special symptoms; they are only discovered during the histological examination of operation specimens. Nevertheless, oestrogenic activity, with resulting endometrial hyperplasia and uterine bleeding, can be associated with some tumours and androgenic activity with others. The probable explanation for these phenomena is that the tumour, by biological or mechanical stimulation, induces a theca cell reaction in the tissues alongside its surface and that the hormones are derived from theca cells and not from the tumour itself.

Malignant Brenner tumours account for 1 per cent of epithelial cancers.

#### *Undifferentiated Carcinoma*

These comprise 1 per cent of epithelial cancers. Two main types are recognised — the large- and small-cell types. High mitotic activity and lack of glandular and squamous differentiation are seen in both types. The small cell type may be associated with hypercalcaemia.

Undifferentiated carcinoma can be differentiated from lymphoma, leukaemia and sarcoma by the use of special immunohistochemical stains.

#### *Ovarian Adenocarcinoma*

The various malignant forms of the epithelial tumours of the ovary are, in practice, usually grouped together as ovarian *adenocarcinoma*. These tumours tend to occur in women aged 45 to 60 years and are commonly asymptomatic until they have achieved a considerable

bulk: the most common complaints are of increasing abdominal girth, lower abdominal pain or discomfort and the presence of a pelvic mass. Urinary symptoms due to pressure on the bladder are quite frequent while disturbances of the menstrual cycle or postmenopausal bleeding are unusual.

The prognosis in any individual case depends upon the tumour type, the clinical stage at the time of diagnosis, the histological grade and type of the neoplasm and the residual disease after surgery.

#### *Tumours of Borderline Malignancy*

These, also known as *carcinoma of low malignant potential*, are forms of the epithelial ovarian tumour that lie somewhere between the benign and malignant varieties. They are seen predominantly in premenopausal women, remain confined to the ovary for long periods and have a very good prognosis. The criteria for the diagnosis of borderline tumours are as follows: epithelial proliferation with papillary formation and pseudostratification; nuclear atypia and increased mitotic activity; and absence of true stromal invasion. It has to be stressed that the diagnosis of a tumour of borderline malignancy is a positive one that is based solely upon the histological findings and that the use of this term does not indicate that the pathologist is unable to determine whether the neoplasm is benign or malignant but that there are no precise grounds for confirming malignancy.

The serous and mucinous tumours largely form this histological group; examples of endometrioid, mesonephroid and Brenner tumours of borderline malignancy, being rare and of a different type, are mentioned later.

Borderline endometrioid tumours are sometimes recognised, either as adenofibromas in which there is a prominent fibromatous component and the endometrial-like epithelial component shows some degree of irregular proliferation, or as areas of atypical proliferation in foci of endometriosis. Borderline mesonephroid tumours are invariably adenofibromas. A particular variant of the Brenner tumour, known as a *proliferating Brenner tumour*, is considered to be this neoplasm's counterpart to the serous and mucinous tumours of borderline malignancy. These are largely tumours which are wholly or partly cystic and, in the majority of cases, behave in a benign fashion though occasional instances of metastasis have been reported.

Overall, about 15-25 per cent of borderline tumours behave in a malignant fashion, invading locally and even metastasising. It is thus important to identify those borderline neoplasms which are likely to behave in a malignant fashion, for it is possible that histological grading of the degree of severity of the epithelial proliferation and atypia may prove to have some prognostic benefits.

#### **Sex Cord Stromal Tumours**

This group of tumours includes all those that contain granulosa cells, theca cells, Sertoli cells or Leydig cells, either singly or in any combination. Some consider that all these cells are derived from the mesenchyme of the genital ridge and call these various neoplasms *mesenchymomas* or *gonadal stromal tumours*. However, it is more likely that both granulosa and Sertoli cells are derived from the primitive sex cords of the developing gonad, either from the coelomic epithelium or from mesenchyme, with the majority favouring an epithelial origin. During embryogenesis the gonad has the potential to develop into either a testis or an ovary; if it is directed to develop along 'male' lines, the sex cords differentiate into Sertoli cells but if development occurs along the ovarian lines, these cells differentiate into granulosa cells. In the adult, undifferentiated cells of sex cord origin retain this bisexual potential and thus may produce either granulosa or Sertoli cell neoplasms, these tumours being homologous. Malignancy of these cells is often accompanied by a stromal reaction; in the case of granulosa cell tumours this adds a thecomatous component to the neoplasm and, in the case of Sertoli cell tumours, there is often Leydig cell differentiation. Additionally, stromal cells themselves can differentiate into either thecomas or Leydig cell tumours. Therefore, the term *sex cord stromal tumours* appears the most logical for this group of neoplasms.

#### *Granulosa and Theca Cell Tumours*

These are composed of granulosa cells and theca interna cells in varying proportions. One consisting mainly of granulosa cells is a *granulosa cell tumour*, while one consisting mainly of theca cells is a *theca cell tumour (thecoma)*; the majority are pure tumours but a proportion of them are mixed. They form smooth-surfaced, round, solid, yellowish white tumours which rarely become larger than an orange, and often show evidence of cystic



degeneration and haemorrhage in their substance. Probably because of physio-chemical changes in the fat content of its cells, the yellow colour generally becomes more obvious after a tumour is removed and exposed to the air.

Granulosa cell tumours are said to arise most commonly after the menopause and before puberty; in fact they occur at any age but mainly in the fifth decade. Theca cell tumours are mostly seen after the menopause.

Feminising tumours metabolise oestrogens in the same way as does the normal ovary and their output is such as to lead to high levels of these hormones in the blood and urine. These are usually accompanied by depression of the secretion of gonadotrophins by the hypothalamic-pituitary system.

The production of oestrogen by these tumours is related to their theca cell content and it is suggested that a granulosa cell tumour is only oestrogenic because the islets of growth stimulate the surrounding stroma to change into functional theca tissue, as happens in the organisation of the normal graafian follicle.

The increased or unopposed acyclic secretion of oestrogen by the tumour acts on the secondary sex organs, causing generalised uterine hyperplasia, uterine bleeding (Figs 33.7 and 33.8), an active vulvar and vaginal epithelium, enlargement of the breasts and even increased libido. The old woman is rejuvenated; the child becomes sexually precocious. When these tumours arise in the young adult they disturb the menstrual cycle,

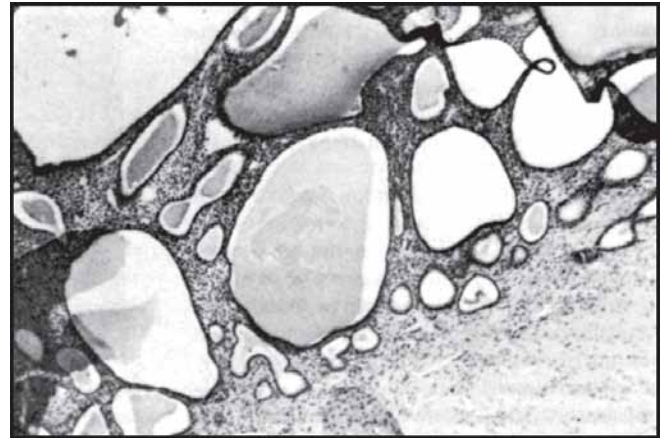
producing short periods of amenorrhoea interspersed with prolonged and irregular haemorrhage.

Carcinoma of the body of the uterus is sometimes seen in association with theca cell tumours and, to a lesser extent, with granulosa cell tumours.

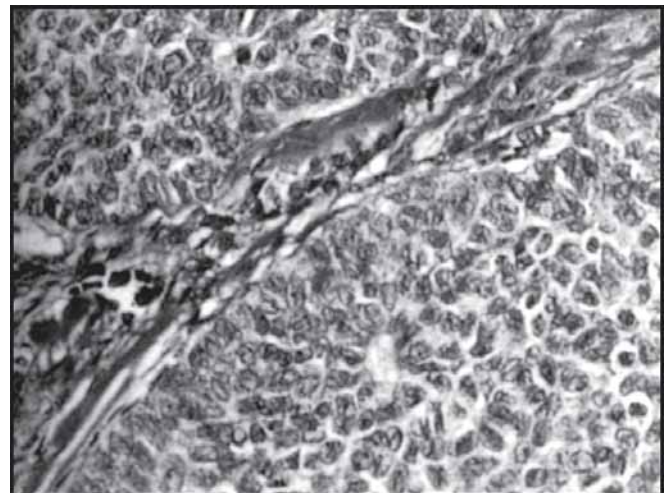
Histologically, the granulosa cell tumour consists of cuboid cells with deeply staining nuclei; these are sometimes arranged diffusely and sometimes in columns, cords, or rounded masses, separated by hyaline tissue. The particular arrangement gives rise to different histological patterns termed folliculoid, cylindromatous and so forth (Figs 33.9 to 33.11). Secretory activity is



**Fig. 33.7:** Myohyperplasia of the uterus with endometrial polyposis caused by a small granulosa cell tumour of the left ovary. The patient in this case was 39 years of age and complained of intractable menorrhagia. She remained well for 11 years after the uterus and both ovaries were removed but then developed a recurrence of the granulosa cell tumour on the floor of the pelvis



**Fig. 33.8:** A photomicrograph showing all the features of cystic hyperplasia of the endometrium of the uterus shown in Fig. 33.7



**Fig. 33.9:** Ovary granulosa cell tumour. This high power view of a granulosa cell tumour of insular pattern emphasizes the uniformity of the constituent cells and demonstrates the rosette-like structures, or Call-Exner bodies, which are typical of the granulosa cell tumour. (Photomicrograph x370)



Fig. 33.10: Showing ovaria ovarian cyst with few solid areas

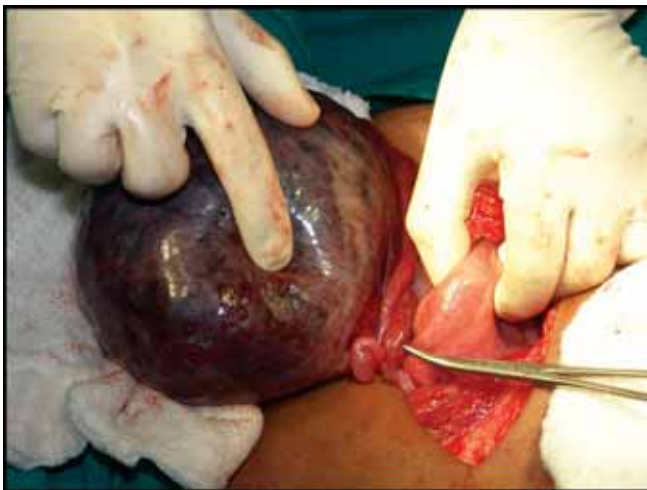


Fig. 33.11: Showing twisted ovarian cyst which is gangrenous

evidenced by the development of fairly large cysts, and by small collections of fluid within the rosettes of cells which create the appearance of *Call-Exner bodies* (Figs 33.9 and 33.11). Some of the cysts are probably formed by the liquefaction of clumps of tumour cells.

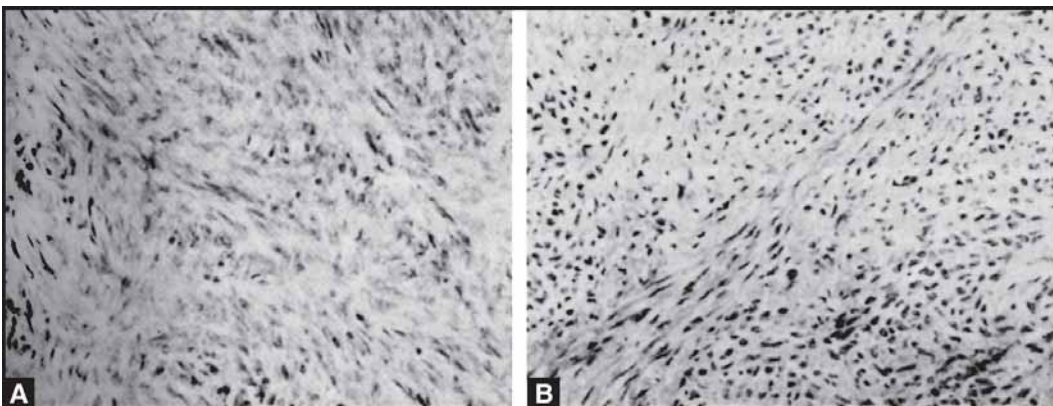
All granulosa cell tumours show great cellular activity and recurrences are common but the time interval may be months or several years. The recurrence is usually local in the pelvis or in the peritoneal cavity.

The theca cell tumour is composed of cells which are more oat-shaped and which are separated from each other by fine fibrils of connective tissue. It is rarely if ever malignant. Its cells contain doubly retractile fats, a point to which many attach great, although unwarranted, diagnostic significance. In fact, cellular fibroma with fatty change is extremely difficult if not impossible to distinguish from a thecoma on histological appearances alone; the main, if not the only, difference between these two connective tissue tumours is that one produces hormones and the other does not (Figs 33.12A and B).

Both granulosa cell and theca cell tumours can become luteinised to form a *luteoma*; they may then produce progesterone as well as oestrogen and convert the endometrium to a secretory phase. This type of luteoma is not to be confused with the luteoma of pregnancy.

#### Androblastomas

Androblastomas are tumours composed of Sertoli cells, Leydig cells or the precursors of either, alone or in any combination. These tumours were previously known as *arrhenblastomas*, which implied that they were invariably



Figs 33.12A and B: Photomicrographs of two different theca cell tumours of the ovary (thecomas). Both tumours had proved oestrogenic activity, (A) This shows an appearance very similar to that of a cellular fibroma and could be mistaken for such, (B) A more characteristic appearance showing interlacing bundles of spindle-shaped epithelioid cells with plump nuclei. If special stains are used the cells of thecomas can be shown to contain fat

virilising but this is not the case. The term *androblastoma* is preferred, not only because it lacks any suggestion of endocrinological activity, but also because it indicates that these tumours reflect phases in the development of the male gonad.

**Sertoli cell tumour:** This benign tumour is rare and usually small. Such tumours are often solid and formed of firm yellowish or orange tissue. Histologically the tumour is composed of highly differentiated uniform tubules lined by a single layer of radially arranged cells with clear cytoplasm and basal nuclei. The epithelial cells may have clearly defined lateral margins and apical surfaces but their cytoplasm often trails off towards the tubular lumen as fine inter-twining tendrils, while the lateral boundaries may be so ill defined that the epithelium has a syncytium-like appearance. The epithelial cells commonly contain lipid droplets and are occasionally markedly distended and vacuolated by fat.

Patients with a Sertoli cell tumour usually present with symptoms suggestive of an endocrinological disturbance and about 70 per cent of these tumours appear to be oestrogenic, the patients complaining of excessive, prolonged or irregular bleeding or of post-menopausal bleeding, and the endometrium often shows evidence of oestrogenic stimulation. About 20 per cent of these tumours appear to be androgenic and produce clinical virilisation, while about 10 per cent are lacking in obvious functional activity.

**Leydig cell neoplasm:** This tumour may arise either from medullary stromal cells or from pre-existing hilar cells. Such tumours are usually small, clearly delineated but not encapsulated, fleshy or soft on section and brown, orange or yellow in colour. Microscopic examination shows the tumour to consist of Leydig cells arranged in sheets or solid cords. The cytoplasm of the Leydig cells is markedly eosinophilic and contains small lipid-containing vacuoles and, often, flecks of yellow-brown lipochrome pigment. The Leydig cell nuclei are large and centrally placed and not uncommonly the nuclei are pooled or aggregated to give an impression of large areas of anuclear cytoplasm. A variant of this usual pattern is the stromal Leydig cell tumour which consists largely of spindle-shaped stromal cells showing focal differentiation into Leydig cells.

Leydig cell tumours usually occur in women aged 50 to 70 years and the majority of patients present with varying degrees of virilisation or defeminisation. A small

proportion of these neoplasms are, however, apparently oestrogenic and some appear to be devoid of functional activity. These tumours are nearly always benign, though a very few cases of metastasising Leydig cell neoplasm have been reported.

**Sertoli-Leydig cell tumours:** These tumours contain a mixture of Sertoli and Leydig cells, though there are strong grounds for believing that the Leydig cell component is due to Leydig cell differentiation in stromal cells that are reacting to the presence of a Sertoli cell tumour.

The gross appearance of these tumours is not characteristic. They are often well-circumscribed and may appear to be encapsulated. The outer surface is usually smooth or bossellated and on section the tumour may be solid, partially cystic or wholly cystic. Histologically there is a very wide spectrum of differentiation. Well-differentiated tumours are composed of tubular structures lined by sertoli-like cells and Leydig cells in variable numbers, between the tubules. Less well-differentiated tumours have a distinguishable epithelial component set in a mesenchymal stroma. The epithelial component consists of reasonably well-differentiated sertoli-type cells arranged in solid tubules, true tubules, trabeculae or solid cords. The mesenchymal element is abundant and contains spindle cells and collagen in varying proportions; mature Leydig cells are present within this stroma as sheets or clusters, or sometimes occur singly. Poorly differentiated tumours consist largely of sheets of closely packed spindle-shaped cells in which occasional irregular cord-like structures or imperfectly formed tubules may be recognised and small groups or clusters of Leydig cells seen. If these are not present, the most that can be diagnosed is tumours that are poorly differentiated as this is a *sex cord-mesenchymal tumour of indeterminate type*.

Androblastomas can occur at any age, but the majority develop in women aged between 10 and 35 years. Abdominal symptoms are not uncommon but endocrinological disturbances tend to dominate the clinical picture. Well-differentiated Sertoli-Leydig cell tumours are commonly androgenic and produce clinical virilisation but occasional instances appear to have been solely, or predominantly, oestrogenic. Over 90 per cent of women with less well-differentiated tumours are virilised to some extent.

The well-differentiated type of androblastoma behaves in a benign fashion. The less well-differentiated forms

also commonly pursue a benign course, though it is recognised that some will recur or metastasise. Unfortunately, the histological appearances of a tumour of this type offer no guide to prognosis. When recurrence or metastasis does occur, this is usually apparent within 12 months and death commonly ensues within 2 years of the initial diagnosis.

*Androblastoma with heterologous elements:* Some Sertoli-Leydig cell tumours are classified separately because, while being otherwise histologically typical, they also contain heterologous elements such as gastrointestinal-type epithelium, striated muscle, fat, bone or cartilage. Some have attributed the presence of these elements to mesenchymal metaplasia but it is also possible that these androblastomas are of teratomatous origin. The clinical and endocrinological behaviour of these neoplasms is identical to that of similar neoplasms lacking heterologous elements.

#### *Gynandroblastoma*

The diagnosis of gynandroblastoma rests solely on morphological grounds and is restricted to tumours in which both granulosa cell and Sertoli-Leydig cell types are present.

Tumours of this type are extremely rare, benign and may be purely androgenic or solely oestrogenic. A few, however, do appear to secrete both oestrogens and androgens.

#### *Sex Cord Mesenchymal Tumour with Annular Tubules*

Another rare but histologically distinctive tumour, this is sometimes bilateral, ranges in size from microscopic to 20 cm across and is solid, being either soft or firm in consistency. The tumour bears some resemblance to a Sertoli cell neoplasm but it is thought that the constituent cells are actually of granulosa origin. About a third of the reported cases of this tumour have occurred in women suffering from the Peutz-Jegher syndrome and this has aroused suspicions that they may be hamartomas rather than true neoplasms.

### Lipoid Cell Tumours

This term applies to a group of rare tumours which are usually virilising, are characterised by an endocrine-type architecture and are formed of large oval polygonal cells which resemble lutein, Leydig or adrenocortical cells.

These neoplasms are probably derived from the ovarian stromal cells, which can differentiate along a variety of pathways to produce a range of tumours of common histogenesis.

The ability of stromal cells to differentiate into Leydig cells is well recognised; many lipoid cell tumours are in fact Leydig cell tumours and, as such, form one type of androblastoma. Some lipoid cell tumours do, however, bear a striking morphological resemblance to an adenoma of the adrenal cortex. These *adrenal-like tumours* are usually virilising and derived from ovarian stromal cells. The tumour is usually benign but there have been a few instances of local recurrence in the pelvis and metastases to lymph nodes, mesentery and liver.

Some lipoid cell tumours do not show clear-cut evidence of either Leydig or adrenocortical cell differentiation and are often classed as luteomas. Both the luteoma of pregnancy and the stromal luteoma are hyperplastic conditions rather than tumours. Most luteomas that have been described have been either Leydig cell, adrenal-like tumours or luteinised thecomas. Tumours which do not fall into any of these categories are described as lipoid cell tumours of indeterminate cell type, there being no morphological or endocrinological grounds for retention of the term 'luteoma'.

#### *Germ Cell Tumours*

The germ cell tumours comprise the teratoma, the endodermal sinus (yolk sac) tumour, the non-gestational choriocarcinoma and the dysgerminoma. The dysgerminoma shows no evidence of differentiation from the germ cell into either embryonic or extraembryonic tissues. Differentiation along embryonic lines gives various forms of teratoma; differentiation along an extraembryonic pathway into the trophoblast results in *choriocarcinoma* and if into the yolk sac structures produces the varying forms of *yolk sac tumour*. However, many germ cell tumours are of mixed type, with various patterns or permutations of dysgerminoma, teratoma, choriocarcinoma and yolk sac being found within a single tumour.

#### *Germ Cell Tumours with Embryonic Differentiation*

*Teratomas:* Tumours consisting of tissues representative of all three primary embryological layers are thought to arise from the ovum itself by varied differentiation of a totipotent cell. In this respect it may be significant that

dermoid cysts similar to those found in the ovary are sometimes found retro-peritoneally, especially in the presacral area.

Whatever may be the mechanism of origin of teratomas, it is remarkable that, in the benign ones at least, the tissues which develop appear to be those normally found in the cranial end of a fetus — hair, skin, teeth, cartilage (of the trachea) and nervous tissues.

Teratomas occur in benign and malignant forms.

*Benign teratomas:* The commonest teratoma is the benign dermoid cyst (mature cystic teratoma). This makes up 10 to 15 per cent of all ovarian tumours and tends to occur at a relatively early age. For this reason it is not uncommon to find it complicating pregnancy. Dermoid cysts are bilateral in 12 per cent of cases and may be multiple in one ovary. Cystic teratomas and mucinous cystadenomas often coexist in the same ova.

A dermoid cyst rarely grows larger than a melon and is unilocular or has very few locules. Its capsule is thick, smooth and greyish yellow in colour, the yellow tint being provided by the sebaceous material within. The lining epithelium is typically stratified squamous and contains the usual cutaneous elements — sebaceous glands, hair follicles and sometimes teeth (variously said to be incisors, bicuspid or molars) (Fig. 33.13). Tissues of the central nervous system, even the choroid plexus, are often present. Cartilage and gastrointestinal epithelium are not uncommon.

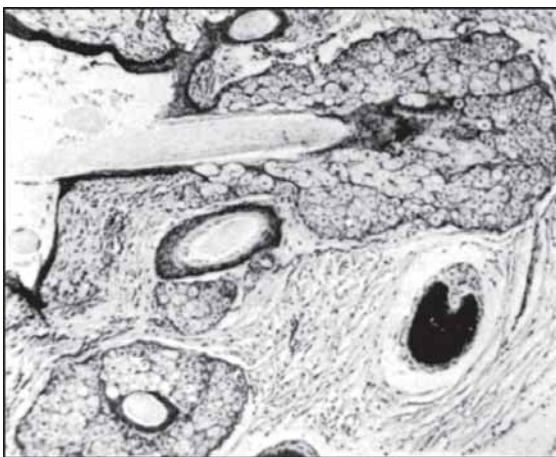
These tissues are mainly distributed around the nodal point which is a centre of activity in one part of the cyst wall (Figs 33.13 and 33.14). Elsewhere the epithelium is

not always stratified and may be transitional and even columnar. Sometimes the epithelium is replaced by granulation tissue and in this it is common to find foreign body giant cells.

The cyst is filled with thick, yellowish, greasy sebaceous fluid which is secreted by the glands in its wall; within this lies hair which grows from the nodal point. Chemical changes in the sebaceous material and fragmentation of the hairs sometimes result in the formation of balls and pellets of fat and hair (Fig. 33.15).



**Fig. 33.14:** A mature cystic teratoma (dermoid cyst) of the ovary opened to show the nodal point from which hair and other tissues grow. The sebaceous fluid contents have been removed



**Fig. 33.13:** The wall of a mature cystic teratoma (dermoid cyst) showing its stratified squamous cell epithelial lining and hair follicles



**Fig. 33.15:** A teratoma (dermoid cyst) containing sebaceous balls and pellets. These stand out because the other tissues of the cyst are extravasated with blood as a result of acute torsion of its pedicle



**Fig. 33.16:** A section of a struma ovarii showing the typical structure of the thyroid gland

It will be noted that the structures in a cystic teratoma are predominantly ectodermal. This is not always the case in the more solid growths which can consist mainly of special tissues. The best example is the struma ovarii - a tumour of thyroid tissue which may be functional and cause hyperthyroidism (Fig. 33.16). Other examples are the lipoma, myoma, chondroma and osteoma.

A rare but interesting derivative of intestinal elements in the wall of a dermoid cyst is the carcinoid tumour. This can cause the 'carcinoid syndrome' in which the patient has attacks of flushing, cyanosis and abdominal cramps. The toxic agent concerned in these symptoms, serotonin and other substances, is normally destroyed by the liver. Since the venous return of the ovary is not to this organ, an argent-affinoma of the ovary causes the syndrome even when no metastases are present. This is in contradistinction to the situation when the primary tumour is in the bowel.

A benign teratoma is characterised by well-differentiated tissues but these can undergo malignant change. It is recognised that the terms 'benign' and 'malignant' are not truly applicable to teratomas, for the prognosis of any individual tumour is determined not by the usual criteria of malignancy but by the degree of maturity of the constituent tissues, those in which all the components are fully mature running a benign course and increasing degrees of tissue immaturity being associated with a progressive tendency towards

malignant behaviour. Hence teratomas are classed as either 'mature' or 'immature', the term 'malignant' being reserved for those cases in which malignant change has occurred in mature tissues, as, for instance, happens in some cases of mature cystic teratoma. For example, there are the various sarcomas which are the counterparts of the mesodermal tumours mentioned above. *Neuromas* and *gliomas* can arise in nerve tissue elements. The wall of a dermoid cyst can develop a *squamous cell carcinoma* and possibly a *melanoma*. The struma ovarii can become the seat of a thyroid cancer.

*Immature teratomas:* The immature teratoma is usually solid and consists of a haphazard mass of rapidly dividing cells of all types without the formation of tissues. This highly malignant neoplasm is seen mostly in childhood and adolescence; it spreads by the bloodstream to the lungs and is usually fatal, although there has been some success with chemotherapy.

#### *Germ Cell Tumours Showing Extraembryonic Differentiation*

*Choriocarcinoma:* Most ovarian choriocarcinomas are combined with other malignant germ cell elements and thus form one component of a mixed tumour. Very occasionally a pure choriocarcinoma of the ovary is encountered but in women of reproductive age such a neoplasm is not necessarily of germ cell origin; it is usually impossible to determine if the malignant trophoblast has arisen from the placental tissue of a primary ovarian pregnancy, from malignant transformation of originally benign trophoblast transported from an intrauterine site to the ovary, as a metastasis from an intrauterine choriocarcinoma which has subsequently regressed, or from neoplasia of germ cells. In prepubertal girls and in postmenopausal women, this problem does not, of course, arise and here an origin from ovarian germ cells which are showing extraembryonic differentiation into trophoblast can be accepted.

The tumour is of variable size, sometimes nodular, and has a variegated appearance on section with extensive areas of necrosis and haemorrhage. The histological features of an ovarian choriocarcinoma are identical to those of a uterine gestational choriocarcinoma with both malignant cytotrophoblast and syncytiotrophoblast being present. The tumour produces hCG. The prognosis is very poor, with rapid pelvic

invasion, intra-abdominal spread and extensive lymphatic and haematogenous dissemination. The ovarian choriocarcinoma responds relatively poorly to the chemotherapeutic regimen which is so successful with gestational uterine choriocarcinoma. This poor response may be due to the fact that many of the tumours classed as ovarian choriocarcinoma are probably mixed germ cell neoplasms.

**Yolk sac tumours.** The *endodermal sinus tumour* is thought to represent germ cell differentiation along extraembryonic lines into extraembryonic mesoblast and yolk sac endoderm.

These tumours form large, encapsulated, smooth or nodular masses of rubbery consistency: the cut surface is yellowish grey with conspicuous areas of haemorrhage and necrosis together with small gelatinous cysts. The histological appearance is complex for, although a number of patterns are usually present, in some tumours one or two of these may predominate.

Endodermal sinus tumours occur predominantly in girls aged between 14 and 20 years and commonly present with non-specific symptoms, an endocrine disturbance not being a feature of the pure yolk sac tumour.

These tumours are highly malignant and, in the past, their rapid spread in the abdomen and to distant sites led invariably to early death. In recent years, however, promising results have been obtained with chemotherapy and the prognosis is relatively hopeful in some cases. The progress of the tumour and the development of recurrences can be monitored by serial estimations of serum alpha-fetoprotein (AFP) levels.

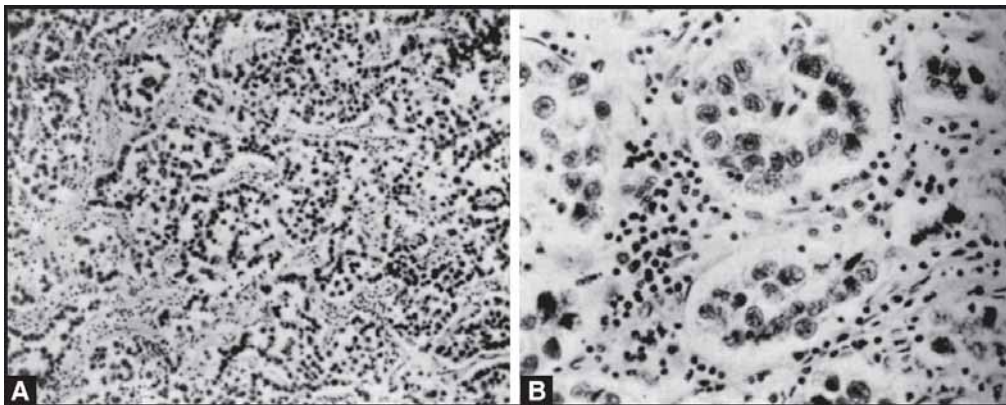
#### Undifferentiated Germ Cell Tumours

**Dysgerminoma.** The prefix 'dis' was originally applied to denote 'two' and not 'difficult' or 'disordered' and refers to the fact that the tumour occurs in both sexes. The dysgerminoma of the ovary is identical with the seminoma of the testis. The prefix *dys* however, is not out of keeping with what is now known about the histogenesis of the growth.

The dysgenetic or streak gonad has a tendency to develop a dysgerminoma (and other gonadocytomas) if the subject has a Y chromosome in her genotype but not otherwise. Nevertheless, most dysgerminomas arise in apparently normal ovaries; it is not uncommon for them to be present during pregnancy. Despite this, there remains a suggestion that the apparently normal girls and women who suffer from this tumour may be mosaics with a Y complement in the tissues of the gonad. This could explain why, unlike most other ovarian tumours, the dysgerminoma is often chromatin-negative.

Macroscopically, the tumour is solid except for any degenerative cystic change; it has the consistency of a soft fibroma and its cut surface has a homogenous appearance rather like that of the mesenchymomas. But the dysgerminoma tends to grow to a much larger size than these. It is bilateral in one-third of the cases.

Microscopically, the tumour is composed of large cells arranged in bundles or alveoli, separated by a characteristic network of connective tissue which is infiltrated with lymphocytes (Figs 33.17A and B). Multinucleated cells, sometimes seen, are probably tumour cells. The appearances mimic those of the gonad at a very early stage of its development and the large tumour cells resemble primitive ova.



**Figs 33.17A and B:** Photomicrographs of a dysgerminoma. (A) A low-power view showing the general appearance, (B) A higher-power view showing clusters of germ cells separated by characteristic bands of connective tissue infiltrated with lymphocytes

Most dysgerminomas are malignant to varying degrees and show evidence of mitotic activity. Even though there is the risk of recurrence, the tumours are highly radio- and chemosensitive. They are bilateral in about 10 per cent of cases. However, in the treatment of the unilateral encapsulated dysgerminoma in young women, a unilateral salpingo-oophorectomy is acceptable if reproductive potential is to be conserved. Careful follow-up is required, especially for the first 3 years, which is the period in which most of the recurrences occur.

Some tumours are not pure dysgerminomas. They can be the seat of a primary choriocarcinoma which secretes gonadotrophins. Other admixtures are theca, Leydig and Sertoli cells. If these are present the tumour may not be 'neuter' but mildly oestrogenic or androgenic. Otherwise, and typically, the dysgerminoma is without any endocrine activity.

This means that, clinically, the patient's only complaints are related to the physical presence of a tumour mass. This is usually detected in youth, before the age of 20 years, and often in childhood.

#### Mixed Germ Cell Tumours

A significant proportion of germ cell tumours show a mixed pattern, with combinations such as dysgerminoma-endodermal sinus tumour, dysgerminomachoriocarcinoma, dysgerminomaimmature teratoma, and immature teratomaendodermal sinus tumour being encountered. Increasing use of methods to demonstrate

the presence of hCG as a marker for trophoblastic differentiation, and AFP as a marker for yolk sac differentiation, have shown that a proportion of germ cell tumours which appeared histologically pure are in fact of mixed type. This applies particularly to dysgerminomas and immature teratomas.

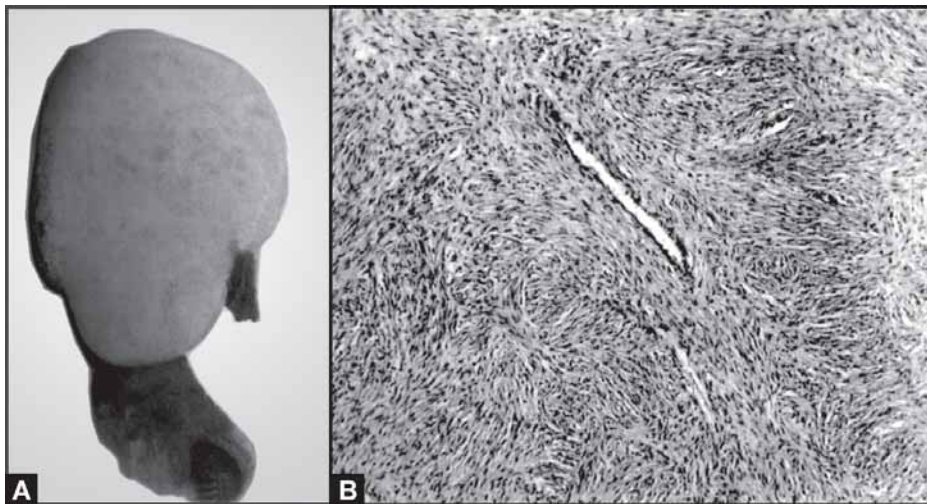
### Connective Tissue Tumours

#### Fibroma

The fibroma represents 3 to 5 per cent of ovarian tumours. It is solid and hard with a white and whorled cut surface, and rarely exceeds a foetal head in size. It is spherical or ovoid in shape but can be lobulated; a bilateral distribution is not uncommon. Sometimes the fibroma is no more than a surface nodule, or is confined to one pole of the ovary (Figs 33.18A and B); sometimes it appears to replace the whole ovary. Although containing no muscle elements, it behaves like a uterine myoma and is subject to the same complications and degenerations. Hyaline change is especially common and most large tumours show some 'cystic' degeneration. Fatty change in fibromas leads to confusion with theca cell tumours, and a calcified fibroma has been mistaken for an osteoma.

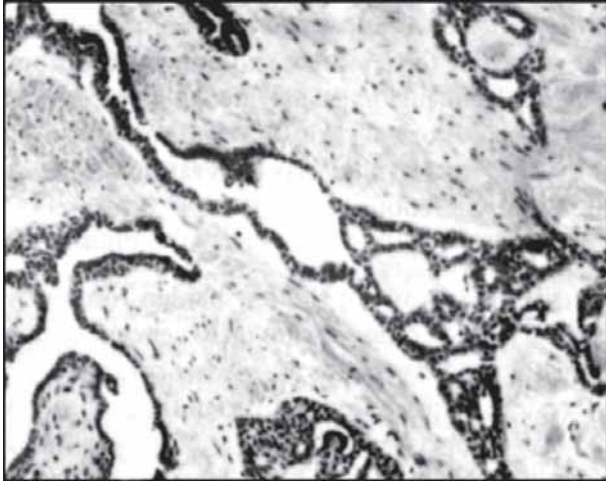
#### Adenofibroma

This is a solid benign tumour which looks and behaves like a fibroma in all respects. On histological examination, however, it is found to contain glandular as well as fibromatous tissues (Fig. 33.19).



**Figs 33.18A and B:** (A) A small fibroma arising from one pole of an ovary; it has been cut across to show the white whorled surface, (B) A photomicrograph (low power) of an ovarian fibroma showing the closely packed interlacing strands of fibrous tissue element





**Fig. 33.19:** Photomicrograph of an adenofibroma of the ovary which to the naked eye looked like a fibroma. This section shows islands of benign glandular tissue lined by cuboidal or low columnar epithelium lying in the fibromatous elements

#### *Other Benign Connective Tissue Tumours*

These include the leiomyoma, lipoma, chondroma, osteoma, haemangioma and lymphangioma. All these are rare pathological curiosities and some examples of the first four named may be teratomas in which one tissue is predominant.

#### *Meigs' Syndrome*

The fibroma is one of the few benign tumours of the ovary which causes ascites in 20 per cent of cases. An associated hydrothorax is also common. The interesting combination of ovarian fibroma, ascites and hydrothorax is called Meigs' syndrome, although Meigs himself pointed out that he only emphasised what had been described previously by Demons of France and Lawson Tait of England. The origin of the fluid is variously ascribed to an exudate from peritoneum resulting from mechanical irritation by the hard heavy mobile tumour, to degeneration of the fibroma, to changes in the capsular veins of the fibroma, to an active secretion by the tumour. The first seems the most likely explanation and is supported by the fact that other types of *mobile* tumour, ovarian or uterine, can cause ascites and give rise to what is then called a pseudo-Meigs' syndrome.

The hydrothorax can be bilateral but is mostly right-sided and some believe that this is because the ascitic fluid tracks through a defect in the diaphragm, such

defects also being more common on the right. Another view, however, supported by anatomical knowledge and experiments with radioactive isotopes, is that the transfer of fluid from the peritoneal to the pleural cavity is by way of lymphatics. The fluid in the pleura is certainly ascitic and not an independent development.

Removal of the fibroma is always followed by spontaneous cure of the hydrothorax and by the *disappearance of pyrexia which is often present in these cases*. According to the purists the criteria for a diagnosis of Meigs syndrome are that the tumour must be ovarian, solid and benign; both hydrothorax and ascites must be present; and removal of the tumour must result in their spontaneous and permanent cure.

A pseudo-Meigs' syndrome is sometimes seen in association with malignant as well as with benign ovarian tumours other than a fibroma and in such cases, it is at first difficult to say whether the hydrothorax is a manifestation of pulmonary metastases. The syndrome can also result from overstimulation of the ovaries with gonadotrophins but, in such cases, the peritoneal exudate is more likely to be caused by an electrolyte imbalance than by the ovarian 'tumours'.

#### *Primary Sarcoma*

Sarcomas of the ovary are rare. The malignant counterpart to the fibroma is the spindle-celled sarcoma but other cell types are described, including the rhabdomyosarcoma.

A variety of other tumours which can occur in the endometrium, such as mixed mesenchymal sarcoma, carcinosarcoma, squamous cell carcinoma and stromal sarcoma, can also develop in the ovary as primary neoplasms.

### Clinical Features

#### *Age Incidence*

With the exception of teratomas and special sex cell tumours, which have their own age incidence already described, primary ovarian neoplasms are most commonly found in women aged 40-60 years. Benign tumours usually commence their growth before the menopause, although they may not become apparent until afterwards. Borderline malignant tumours are seen more frequently between the ages 30 and 50 years whereas invasive carcinomas are seen more frequently between 50 and 70 years. Approximately 45 per cent of tumours

removed from patients aged 45 years and over are malignant in part or whole.

### Genetic Factors

Familial patterns have been seen in less than 5 per cent cases of epithelial ovarian cancer. These fall into one of these categories.

*Site-specific familial ovarian cancer:* Here the pattern of inheritance is autosomal dominant with reduced penetrance. If two first-degree relatives are affected the risk is as high as 50 per cent; with one first-degree relative affected, it is 2-4 fold. These women develop the cancer 10 years earlier than the median age.

*Breast/ovarian familial cancer syndrome:* Here there is a combination of these two types of cancer seen in first and second degree relatives. The BRCA 1 and BRCA 2 genes of the 17q chromosome has been associated with the syndrome. Individuals with a BRCA 1 minimum have an 85-90 per cent risk of developing breast cancer and a 50 per cent risk of developing ovarian cancer.

*Lynch II syndrome:* This includes multiple adenocarcinomas — familial colon (Lynch I), ovarian, endometrial and breast cancers as well as other malignancies of the gastrointestinal and genitourinary systems, the malignancy appearing before the age of 40 years. A detailed pedigree is needed to work out the exact risk, which is roughly 3 times that in the general population.

### Symptoms

Excluding those which have an endocrine function, ovarian tumours are amazingly quiet and rarely give *rise to symptoms* other than those induced mechanically by the size of the mass. It is this feature which makes them so dangerous; malignant ones are often inoperable by the time they are diagnosed, commonly in Stages III and IV.

An abdominal swelling may be noticed by the patient or discovered during routine medical examination. A large tumour or associated ascites causes indigestion, vomiting and frequency of micturition. *Dyspepsia of some kind is the leading symptom* of ovarian tumours, especially malignant ones. For this reason, cases of ovarian cancer are often first seen by physicians rather than by gynaecologists. A tumour which becomes impacted in the pelvis causes retention of urine, or may be found obstructing labour; it rarely, if ever, results in difficulty in

evacuating the bowel. Oedema of the legs and of the vulva, and varicose veins are quite exceptional unless the tumour is malignant. Cachexia is common with all large growths, even when they are benign.

A benign tumour is never painful unless some accident overtakes it. A malignant one often causes an aching pain in the abdomen and localised to the tumour. The explanation of this is unknown; it can occur even before the growth erodes its capsule and is exposed to peritoneum.

In the case of metastatic cancers there may be symptoms caused by the primary lesion or there may be a history of its having been treated.

Neither malignant nor benign growths usually affect the menstrual function in any way unless they happen to have a sex endocrine function. Even if *both* ovaries are the seat of large tumours there is always enough normal ovarian tissue left to continue a regular menstrual cycle.

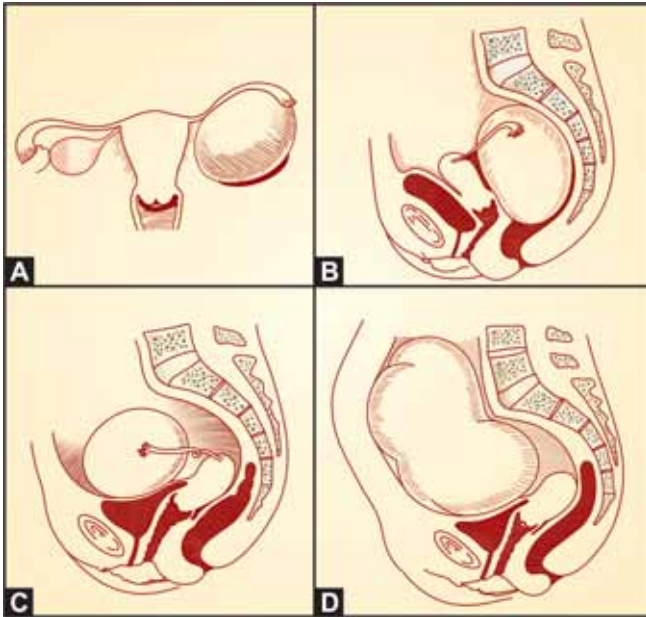
Nevertheless, 30 per cent of postmenopausal women suffering from ovarian tumours report having had some, albeit slight, uterine bleeding. In the past such an occurrence was regarded as evidence of the growth being malignant. In fact it is explained in the majority of cases either by the effect of the tumour, benign or malignant, on the surrounding ovarian stroma, or by associated changes in the vascularity of the pelvic organs. Only rarely does it indicate an oestrogenic tumour.

### Physical Signs

Small ovarian tumours lying in the pelvis can only be palpated on vaginal or rectal examination; they usually lie behind the uterus and possibly, but not always, a little to one side. If one is found in the uterovesical pouch it is probably either a dermoid cyst or its pedicle has undergone torsion (Figs 33.20A to D).

When an ovarian tumour emerges from the pelvis it comes to lie behind the abdominal wall, displacing the intestines above and to the side, the uterus usually lying below and behind its lower pole. On abdominal examination, therefore, an ovarian tumour is always dull to percussion, with areas of resonance in the flanks (*see* Fig. 1.2). This simple and obvious sign allows a clear distinction between an ovarian cyst and ascites in nearly all cases.

Cysts are often so tense that they give the impression of being solid, especially if they are multilocular. When the cyst walls are thin and flaccid and the contents watery,



**Figs 33.20A to D:** The common positions of ovarian tumours in relation to the uterus: (A) a small tumour lies to the side; (B) a medium-sized tumour lies behind; (C) a small or medium-sized tumour which lies in front is likely to have its pedicle twisted; (D) a large tumour lies above and in front of the uterus, immediately behind the abdominal wall

a fluid thrill is obtained and ascites may be suspected. In such a case, the finding of even one small patch of resonance in one or other flank is diagnostic of encysted fluid. An ovarian tumour which reaches the abdominal cavity tends to lie centrally, so its position is of no value in distinguishing it from a uterine swelling. Moreover, it is rarely possible on physical signs alone to be sure which ovary is the origin of the tumour. Even if the tumour is in the pelvic cavity and is lying well to one side, it may still arise from the opposite ovary.

Difficulty may be encountered if ascites complicates the picture; indeed some of the peritoneal exudate may have to be removed before the ovarian tumour becomes palpable. If paracentesis is carried out, microscopic examination of the centrifuged fluid is an important means of distinguishing between a malignant effusion and one which is a manifestation of a Meigs' or Pseudo-Meigs' syndrome.

### Diagnosis

An ovarian neoplasm has to be distinguished from all *other abdominal tumours*, the commonest sources of

confusion being a distended bladder; pregnancy; obesity; ascites; pseudocyst and phantom tumours; a mesenteric cyst; an appendix abscess; an enlarged liver or spleen; retroperitoneal tumours; a large hydronephrosis; and hydatid (echinococcal) cysts.

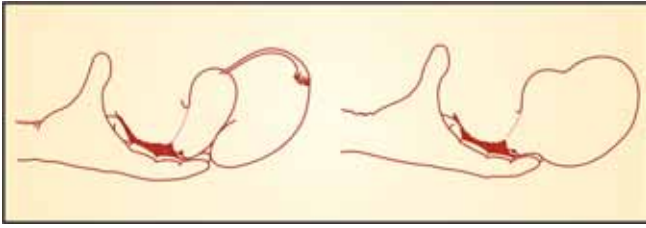
It has also to be distinguished from *other pelvic tumours* and especially from pregnancy; uterine leiomyomas; broad ligament tumours; endometriosis; a pyosalpinx or hydrosalpinx, ectopic pregnancy; a pelvic abscess; diverticulitis; tumours of the colon and rectum; a pelvic kidney; retroperitoneal tumours including an anterior meningocele; and a *cystic ovary*.

Mistakes are least likely if attention is paid to the following points:

- Do not neglect the history and symptoms; menstrual disturbance, for example, is *against* the diagnosis of ovarian cyst.
- Empty the bladder by passing a catheter.
- Think of pregnancy.
- Allow percussion to take precedence over all other methods of abdominal examination (*see* Fig. 1.2).
- Auscultation can be helpful. A peritoneal rub distinguishes an ovarian cyst from ascites. A *souffle* means that the tumour is more likely to be uterine than ovarian. The foetal heart sounds are absolute proof of pregnancy.
- On pelvic examination, concentrate on determining whether the swelling is attached to, or part of, the uterus, whether it moves with the cervix, and whether the uterus or an ovary can be felt apart from it. In difficult cases a good guide is the presence or absence of a sharp cleft between the uterus and the lower pole of the tumour (Fig. 33.21). If the uterine vessels can be felt pulsating strongly through one or both vaginal fornices, the tumour is probably uterine.
- Think of the pelvic kidney.

Additional aids to diagnosis are:

- Direct radiological examination of the abdomen for evidence of a foetal skeleton, calcification in a leiomyoma, or teeth in a dermoid cyst (Figs 33.22A and B). Intravenous urography (IVU) or barium meal or enema investigation carried out for other reasons may reveal these findings.
- Ultrasound for delineating the site and size of the lesion. Several ultrasonographic criteria have been used to devise scoring systems for differentiating benign from malignant tumours. In general, benign lesions are likely to be unilateral, unilocular, thin-



**Fig. 33.21:** Distinguishing between a uterine and an extrauterine tumour by feeling or not feeling a notch on vaginal examination

walled with no papillae or solid areas. Septae, if present, are also thin. In contrast, malignant lesions are often multilocular with thick walls, thick septae and a mixed echogenicity because of the presence of solid areas.

The role of ultrasound in screening is still unclear. In general it is accepted that patients at high risk for ovarian carcinoma, e.g. those with a family history, should be monitored every 1-2 years with transvaginal ultrasonography. In postmenopausal women the palpable ovary may be significant — postmenopausal palpable ovary (PMPO) syndrome. Cysts smaller than 5 cm diameter are unlikely to be malignant but those larger than 5 cm have a 10 per cent likelihood of malignancy.

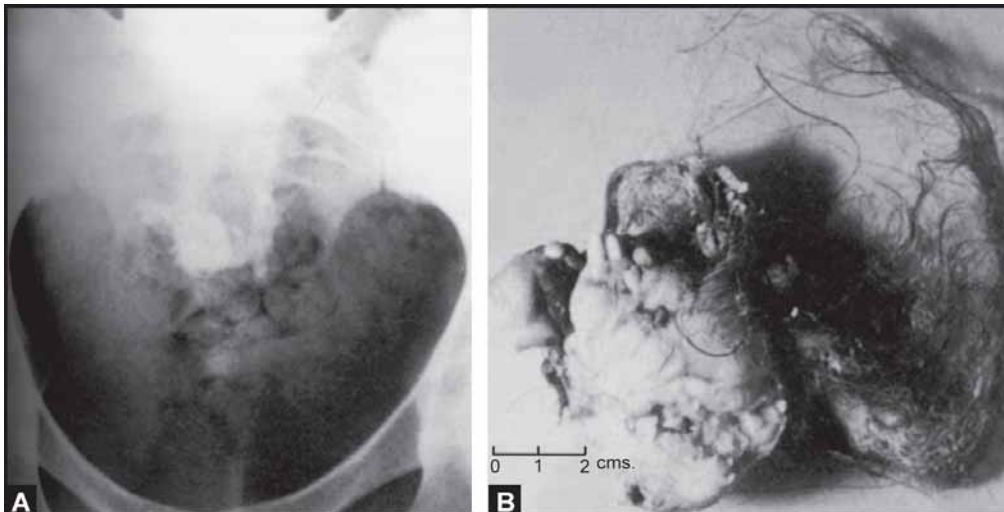
- Colour flow imaging to increase the specificity of diagnosis. In malignant tumours the resistance

incidence is usually low (<0.4) and there is a high peak velocity.

- CT scan and MRI can be used to evaluate the tumour and extent of spread but are more useful in monitoring the progress of disease.
- Tumour markers—Various tumour markers have now been developed which may help in differentiating benign from malignant lesions. More importantly, if serum levels are elevated preoperatively, they are useful in follow-up and for the detection of recurrence.

For epithelial ovarian tumours the most important of these is serum CA-125, a surface glycoprotein. Elevated values of more than 35 U/ml are found in over 80 per cent of patients with non-mucinous epithelial ovarian cancers (PPV 75-96 per cent) but in only 1 per cent of the general population. CA-125 can also be elevated in inflammatory conditions involving the peritoneum, e.g. tuberculosis and endometriosis, though to a lesser level. Other markers can be used in combination with CA-125 to improve the predictive value, e.g. CA 15-3 is elevated in breast cancers but not in ovarian cancer so it rules out false-positive results; CA 19-9 is elevated in mucinous ovarian malignancy and in gastrointestinal cancers.

Carcinoembryonic antigen (CEA) levels higher than 5 mg/L are seen in 88 per cent of mucinous cancers but in only 29 per cent of epithelial cancers.



**Figs 33.22A and B:** The diagnosis of a mature cystic teratoma (dermoid cyst) by radiography, (A) An area of calcification with clearly recognizable teeth in the pelvis, (B) The well-formed teeth show in (a) in the specimen after removal. From the nodal point in this cyst there is also an abundant growth of hair. This teratoma was in fact found adherent to the back of the uterus, both ovaries being normal. It might, however, have arisen in an accessory ovary. The patient in this case was 22 years of age and complained only of infertility

Other tumour markers such as lipid-associated sialic acid (LSA), NB/70 K and Tag 72 are not used in general practice. Macrophage colony stimulating factor (MCSF) and monoclonal antibody ovarian XI (OV XI) have been found to be indicative of a positive second-look laparotomy (see below) even if CA-125 is normal. For stromal tumours, oestrogen, androgens and inhibin have been used as tumour markers. In germ cell tumours, the value of tumour markers has been proved for a long time. Alpha-fetoprotein, hCG, lactic dehydrogenase (LDH) and even CA-125 are used but the first two are more commonly used. Alpha-fetoprotein can be elevated in all except dysgerminoma and choriocarcinoma, hCG in all except embryonal sinus tumour and immature teratomas.

- Laparoscopy — If the nature of the tumour is in doubt. Treatment can be carried out at the same time.

A small ovarian neoplasm has to be distinguished from a cystic ovary. Clinical features such as a history of menstrual upset often make this clear but, if there is doubt, other methods of differentiation are: laparoscopy or re-examination at intervals, clinically and by ultrasound — a follicular or corpus luteum cyst is likely to disappear spontaneously, whereas a neoplasm persists.

When an ovarian neoplasm is diagnosed it is next necessary to determine whether it is primary or metastatic. A full clinical examination is therefore essential and a *radiological examination of the alimentary tract is desirable* if a secondary tumour is suspected. When the lesion appears to be primary in the ovary, it remains necessary to decide whether it is benign or malignant.

The clinical features suggesting malignancy in ovarian tumours are as follows:

## AGE

Ovarian neoplasms found in childhood are usually malignant or locally malignant. Otherwise the risk of malignancy is roughly proportional to age and ranges from 20 per cent before the menopause to 50 to 60 per cent afterwards.

## PAIN AND TENDERNESS

A dull aching pain (as distinct from a sudden acute pain caused by torsion or rupture) and tenderness over one or other aspect of the tumour is very suggestive of

malignant change. *This is often the first* and most reliable *evidence*. Sacral nerve root pains strongly indicate very advanced malignancy.

## Rapidity of Growth

A rapidly growing tumour is suggestive of malignancy.

## The Consistency of the Tumour (Fig. 33.10)

Solid, nodular and irregularly shaped growths are more likely to be malignant than are smooth cystic ones.

## Number of Tumours

Seventy-five per cent of malignant tumours are bilateral as compared with 15 per cent of benign ones. The presence of two tumours is therefore suggestive but not conclusive.

## Fixation of the Tumour

This is an ominous sign but can also be caused by impaction of the tumour, by its occurrence in an extraperitoneal site, and by an associated lesion such as endometriosis.

## Ascites

The presence of free fluid in the abdominal cavity usually means peritoneal metastases, or at least that the tumour has perforated the ovarian capsule. It is more significant if the fluid is bloodstained because a clear exudate is also sometimes seen with a fibroma, with cystadenomas, especially those of the papilliferous type, and with other benign tumours.

## Oedema of the Feet and Vulva; Varicosities

Obstruction of the venous or lymph return practically never occurs with a benign tumour, no matter how large it may be. Oedema of the vulva and/or legs nearly always means cancer.

## Metastases

Ovarian tumours, other than highly malignant sarcomas and teratomas which spread by the bloodstream to the lungs, rarely produce remote metastases. The finding of a hydrothorax does not necessarily mean pulmonary deposits, even when the ovarian tumour is malignant. The liver is also relatively immune.

Secondary deposits are usually seen only in the omentum, and on the visceral and parietal peritoneum (including the undersurface of the diaphragm) which becomes studded with small nodules. A common site for these is the pouch of Douglas and *they are often palpable on vaginal examination*.

The lymph nodes most likely to be involved are the aortic groups. The supraclavicular nodes are sometimes enlarged and should always be examined. Secondary nodules are occasionally seen in the umbilicus which the cancer cells reach through the lymphatics of the obliterated hypogastric arteries and of the urachus (Figs 33.23A and B). Vaginal metastases are rare and usually denote bloodborne emboli.

### Borderline Tumours

An important group of tumour to distinguish is the tumour of low malignant potential, also called the borderline tumour. Borderline tumours are lesions that tend to remain confined to the ovary for long periods, occur predominantly in premenopausal women, and are associated with a very good prognosis. They are encountered most frequently in women between the ages of 30 and 50 years, whereas invasive carcinomas occur more often in women between the ages of 50 and 70 years.

Although uncommon, metastatic implants may occur with borderline tumours. Such implants have been

divided into noninvasive and invasive forms. The latter group has a higher likelihood of developing into progressive, proliferative disease in the peritoneal cavity, which can lead to intestinal obstruction and death.

The criteria for the diagnosis of borderline tumours are as follows:

1. Epithelial proliferation with papillary formation and pseudostratification
2. Nuclear atypia and increased mitotic activity
3. Absence of true stromal invasion (i.e., without tissue destruction).

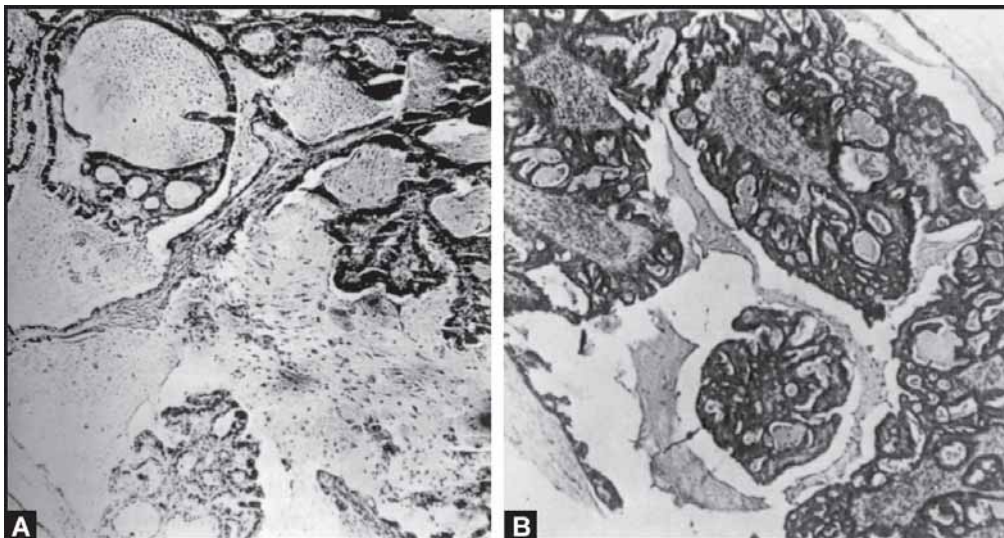
It should be emphasised that about 20 to 25 per cent of borderline malignant tumours spread beyond the ovary. The diagnosis of borderline malignant versus malignant ovarian tumour must be based on the histologic features of the primary tumour.

### Complications

*Torsion of the Pedicle (Fig. 33.11)*

Axial rotation is more likely to involve small tumours because large ones are restricted in their movement, but no type is immune. Because they are usually relatively small and mobile, by reason of a long pedicle, dermoid cysts are said to be the most prone of all tumours to suffer this accident.

The clinical features, causes and treatment of axial rotation are described in Chapter 18. Here it only remains



**Fig. 33.23:** A mucinous cystadenoma of the ovary which had become malignant, (a) Photomicrograph of the original tumour which had naked-eye appearances typical of cystadenoma and histological features of borderline malignancy and which had been removed together with the uterus and opposite ovary, (b) A metastasis excised from the umbilicus 2 years after the removal of the ovaries. At this second operation multiple metastases on the peritoneum were seen but, despite these, and despite not having any further treatment, the woman survived for a further 3 years

to be added that intermittent and incomplete torsion can lead to degenerative changes in the cyst wall which then becomes adherent to adjacent organs, especially the omentum. These adhesions can contribute a new blood supply to the tumour which, when severed from its original connection, then becomes *parasitic* (Fig. 33.24).

### Haemorrhage Into or from a Cyst

A vessel in the wall of the tumour can rupture into the peritoneal cavity or into the tumour itself. Small haemorrhages into the cavity of a cyst are common and, at the time of their occurrence, do *not* cause pain and tenderness in the tumour. The bleeding is self-limiting and not of great importance, but it accounts for the various colours of cyst fluids. Intraperitoneal haemorrhage causes pain, collapse and peritonism.

### Rupture of a Cyst

This accident is usually a spontaneous occurrence but it can result from external trauma, or during labour, coitus and pelvic examination. Rupture is more likely if the wall of the cyst is already damaged by previous ischaemic

degeneration, if the cyst is papilliferous in type, or if it is malignant. The symptom is acute onset of pain followed by varying degrees of collapse. Sometimes the patient feels that 'something has given way' but is thereafter not seriously incommode. On the other hand vomiting, diarrhoea and other signs of peritoneal irritation can follow. Shoulder-tip pain resulting from fluid under the diaphragm is a possible symptom.

If the cyst was known to be present previously, its size may be noticeably reduced and it may be possible to demonstrate free fluid in the peritoneal cavity. If the patient has not been seen previously and the tumour has collapsed it can be extremely difficult to make the diagnosis.

The most severe peritoneal reaction follows leakage of the sebaceous contents of a dermoid cyst. The initial picture is then one of acute abdomen often accompanied by pyrexia. The subsequent effect is to produce adhesions far more dense and difficult to separate than those attending infection or endometriosis.

A possible late sequel to rupture of a mucinous cystadenoma is pseudomyxoma peritonei.

### Degeneration

With the possible exception of red degeneration, fibromas are subject to the same types of degeneration as are uterine fibroids. Most large solid tumours show evidence of necrosis and haemorrhage in their centres.

### Infection

Infection was a common complication when cysts were treated by tapping rather than by removal. This is now seen only as a complication of pelvic peritonitis and salpingo-oophoritis, or when organisms spread from the bowel to a tumour whose viability is impaired by ischaemia. Necrosis following torsion of the pedicle is a common forerunner to infection of an ovarian tumour.

### Intestinal Obstruction

This rarely occurs with benign tumours but is very likely with malignant ones to which loops of small intestine become adherent. It is the commonest mode of death from ovarian cancer.

### Malignancy

All benign ovarian tumours can become malignant, although probably not more than 5 to 10 per cent have done so by the time they are treated.



**Fig. 33.24** A parasitic mature cystic teratoma (dermoid cyst) visible on the radiograph as a round soft tissue shadow containing a tooth, high in the abdomen and level with the lower pole of the left kidney. The patient in this case suffered from repeated attacks of pain during late pregnancy and these were attributed to left-sided pyelonephritis; hence the pyelography carried out after her delivery. Laparotomy revealed a gangrenous dermoid cyst and left ovary, severed from all pelvic connections, and adherent to the colon and mesocolon at the splenic flexure

## Staging of Ovarian Cancer

Whenever malignancy is suspected, a staging laparotomy should be carried out. The abdomen is opened through a midline incision to allow adequate access to the upper abdomen. If a transverse incision is made, splitting of the rectus muscles is required. The steps of the staging laparotomy are as follows:

- Any free fluid is heparinised and submitted for cytologic evaluation. If there is none, peritoneal washings are taken with 50-100 ml of heparinised saline from each of the following sites: the pouch of Douglas, the paracolic gutters and the sub-diaphragmatic spaces. For the last, a rubber catheter attached to a bulb syringe is used.
- All the intra-abdominal viscera and surfaces are explored systematically — the caecum, ascending colon, paracolic gutter, right kidney, liver, gall bladder, right hemidiaphragm, transverse colon, left hemidiaphragm, left paracolic gutter, descending colon, sigmoid colon, the small intestine and its mesentery.
- Biopsies are taken from suspicious areas and adhesions. If there are none, multiple random biopsies are taken from the peritoneum of the pouch of Douglas, both paracolic gutters, over the bladder and the intestinal mesentery.
- Biopsies from the diaphragmatic surface can be taken with the aid of a laparoscope or the surface can be scraped with a tongue depressor and the sample sent for cytologic evaluation.
- The retroperitoneal spaces are explored to evaluate the pelvic and para-aortic lymph nodes and all enlarged lymph nodes resected.
- An infracolic omentectomy is performed.
- Ovarian tumours should preferably be removed intact.

The importance of thorough surgical staging cannot be overemphasised, because subsequent treatment will be determined by the stage of disease. For patients in whom exploratory laparotomy does not reveal any macroscopic evidence of disease on inspection and palpation of the entire intraabdominal space, a careful search for microscopic spread must be undertaken. In earlier series in which patients did not undergo careful surgical staging, the overall 5-year survival for patients with apparent stage I epithelial ovarian cancer was only about 60 per cent. Since then, survival rates of 90 to 100

per cent have been reported for patients who were properly staged and were found to have stage Ia or Ib disease.

As this is not done routinely by gynaecologists many of the cases considered to be early stage ones are not in fact so. The silent nature and tendency for early spread is emphasised by the fact that two-thirds of all cases of malignant ovarian disease are in Stage III or IV when the diagnosis is made. The proper staging of ovarian cancer, as with other gynaecological malignancies, determines the appropriate therapy and prognosis. The staging recommended by FIGO (1988) is as follows.

*Stage I:* Tumour limited to the ovaries

- A. Limited to one ovary; capsule intact; no tumour on surface; no malignant cells in ascitic fluid or peritoneal washings
- B. As in IA; limited to both ovaries
- C. Limited to one or both ovaries: capsule ruptured; tumour on surface; malignant cells in ascitic fluid or peritoneal washings

*Stage II:* Tumour involving one or both ovaries with pelvic extension

- A. Extension to, or metastases in, the uterus and/or tubes; no malignant cells in ascitic fluid or peritoneal washings
- B. Extension to other pelvic tissues, uterus and/or tubes
- C. As in IIA or IIB with malignant cells in ascitic fluid or peritoneal washings.

*Stage III:* Tumour involving one or both ovaries with microscopically confirmed peritoneal metastases beyond pelvis and/or regional lymph node metastases; liver capsule metastases

- A. Microscopic peritoneal metastases beyond pelvis
- B. Macroscopic peritoneal metastases beyond pelvis (greatest dimension <2 cm)
- C. Peritoneal metastases beyond pelvis (greatest dimension >2 cm) and/or regional lymph node metastases

*Stage IV:* Distant metastases (excludes peritoneal metastases). Liver parenchyma metastases or positive cytological confirmation of a pleural effusion.

## Treatment

### *Ultrasound-guided Cyst Aspiration*

This is a controversial procedure because in one- to two-thirds of women the fluid will reaccumulate. It can be considered in a young woman with a unilateral, unilocular, anechoic, thin-walled cyst less than 10 cm in diameter which appears benign.



### Paracentesis

The place of paracentesis is in the treatment of proven inoperable malignant cysts, its object being to relieve abdominal distention and discomfort due to either the cyst or ascites, during the last few weeks or months of life. In advanced disease, it may help to establish the diagnosis of malignancy and provide the basis for neoadjuvant chemotherapy.

### Surgery

#### Indications

If it is reasonably certain that an ovarian tumour is neoplastic in type and not merely a functional cyst, surgery *is always indicated*. This is true even though the tumour is symptomless because of its liability to one of the complications enumerated above and because it is never possible to be certain that it is not or will not become malignant.

Generally, the ovarian tumour should be removed entire, even if this means a long incision in the abdominal wall (*see below*). Tapping of a cyst to reduce its size at an early stage of an abdominal operation *may* be permissible in women less than 40 years of age, when the cyst is obviously benign and when there is no suggestion that it is a dermoid, or in very old frail women whose poor healing powers might make a long abdominal incision dangerous – large cysts in this type of patient are almost always benign.

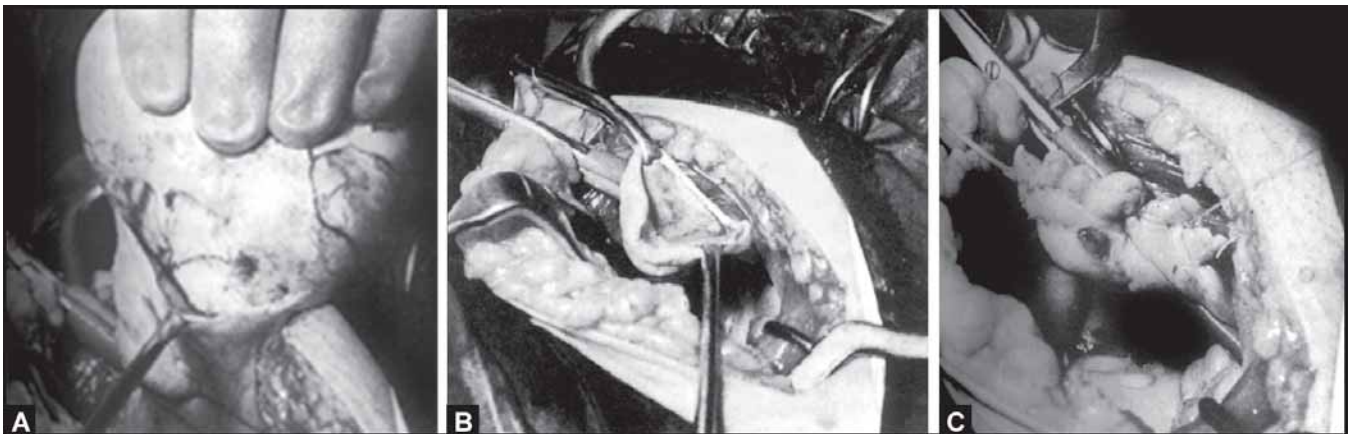
If, as sometimes happens, a cyst wall ruptures during an operation, the contents should be carefully mopped

from the peritoneal cavity. When a malignant cyst ruptures inadvertently, it does not usually increase the chances of recurrence of the growth. In this sort of circumstance, proper staging with multiple biopsies and radical surgery plus systemic post-operative chemotherapy is the best course of action. There are many cases in which, by the time the patient is seen, the clinical features strongly suggest that the tumour is malignant and already irremovable. It is sometimes argued that laparotomy is then unjustified because it may hasten death. However, the abdomen should generally be opened no matter how poor the prospects appear because it is never possible to be certain and sometimes the condition proves to be surprisingly amenable to treatment. The other option is neoadjuvant chemotherapy (*see below*).

#### Types of Procedure

The surgical procedure to be adopted when the tumour is exposed depends on the age of the patient and whether or not the tumour shows evidence of malignancy at operation.

*Cystectomy.* In young women and irrespective of tumour size it is possible and usually wise to dissect a benign tumour out of the ovary. Ovarian tissue is spread out in a thin layer over one aspect of the growth and can be preserved and remodelled into a more or less normal and functional organ (Figs 33.25A to C). This conservative operation is sometimes indicated, even when the pedicle of the tumour has been twisted, provided that the tissues are viable.



**Figs 33.25A to C:** Cystectomy for a cystic teratoma of the ovary, (A) A light bowel clamp has been placed across the mesovarium to control bleeding. The ovarian capsule is incised and the tumour is beginning to shell out. (B) The bed of the tumour in the remaining normal ovarian tissue, (C) The ovary reconstituted

During the operation bleeding can be controlled, if necessary, by placing a light bowel clamp across the mesovarium. At the conclusion, care is necessary to see that haemostasis is complete.

Cystectomy generally gives excellent results but has two disadvantages. An apparently benign tumour may prove to be malignant on subsequent microscopic examination. This does not often happen because a malignant tumour, by invading the capsule, makes its clean dissection from the ovary impossible. Difficulty in shelling out the tumour is, therefore, a reason for abandoning attempts at cystectomy. If a malignant tumour is inadvertently removed by cystectomy, the appropriate treatment depends on the type of tumour. In general it will be necessary to reopen the abdomen and to be radical after careful staging.

*Ovariectomy and salpingo-oophorectomy:* The term ovariectomy is used to describe the removal of the whole ovary and tumour. Ovariectomy is indicated whenever there is doubt about the nature of a tumour and it is generally best to remove the tube as well. If the patient is more than 45 years of age the opposite ovary and uterus should also be removed after proper staging because of the greater chance that the tumour is malignant. The advantage of conservatism at that age does not outweigh the risk of an apparently normal ovary becoming neoplastic at a later date. In younger women, one ovary should always be conserved if possible. In such subjects, the chance of the remaining ovary developing a tumour, benign or otherwise, subsequent to unilateral salpingo-oophorectomy for a *benign* neoplasm is little, if any greater than it is for all women of comparable age.

*Laparoscopic surgery:* Laparoscopic surgery is the preferred mode of surgery in young women below 35 years of age with ultrasound features of a benign cyst as described above. Usually these are simple ovarian cysts or cystadenomas, benign cystic teratomas or endometriomas.

Several procedures are commonly used: aspiration and fenestration; cystectomy; oophorectomy or salpingo-oophorectomy. Laparoscopic guidance can also be used to direct the cyst towards a minilap incision.

Aspiration is usually not recommended as it encourages spill and recurrence; it may fail to diagnose a malignant lesion. It is preferable to bring out the cyst intact wherever possible.

Whenever laparoscopic surgery is considered, facilities should be available for converting the case to

laparotomy and performing adequate surgery should the tumour prove to be malignant.

*Total hysterectomy with bilateral salpingo-oophorectomy:* This is the best operation for all tumours - malignant, doubtful or benign - in women aged 45 years and over. Before that age this operation may still be indicated for *malignant* tumours. The features suggesting malignancy at the time of operation are solidity of the tumour or solid areas in a cystic tumour; tumour tissue fungating through its ovarian capsule; large blood vessels on its surface; areas of haemorrhage showing through the outer wall; free peritoneal fluid, especially if it is blood-stained — confirmatory evidence can be obtained by cytological study of a specimen of this fluid or, in the absence of peritoneal fluid, of a saline wash of the pelvic cavity; adhesions to other structures; a bilateral distribution; and metastases on the peritoneum or in the omentum — in this respect papillae associated with papilliferous cysts are not necessarily malignant.

For obviously malignant tumours, proper staging should be carried out. The abdominal incision should be midline which can be extended as far upward as necessary. In all malignant cases the principle is to remove all of the tumour plus the potential areas of spread. This means a total hysterectomy and bilateral salpingo-oophorectomy, and infracolic omentectomy. If it is impossible to remove all the tumour then as much as can safely be removed should be. The reason is simple - the smaller the amount of residual tumour, the more effective is chemotherapy.

The cavitron ultrasonic surgical aspirator (CUSA) is used at some centres to achieve maximal cytoreduction.

### *Conservative Surgery*

The question of conservative surgery arises when the patient is young and only one ovary is malignant. In the case of epithelial ovarian cancers, the role of conservative surgery is still not clearly defined. It can be considered in well-differentiated Stage IA tumours. Several such patients with 5-year survival are now reported, but longer follow-up is awaited.

In the case of germ cell tumours, conservative surgery is well-documented. It is the preferred mode of treatment as most of these patients are young, future fertility is desired and the tumours respond well to chemotherapy. Thus a unilateral oophorectomy is sufficient even in the presence of metastatic disease but readily resectable deposits are removed. Except for dysgerminomas these

tumours are not usually bilateral so the contralateral ovary is biopsied only if an abnormal area is seen. If bilateral salpingo-oophorectomy is required the uterus can still be retained and the case considered for oocyte donation and assisted reproduction at a later date. Post-operatively the patient receives chemotherapy. If, however, fertility does not need to be preserved, the standard surgical protocol described above is followed.

In Stage IA sex cord stromal tumours in children or young women, a unilateral salpingo-oophorectomy is appropriate therapy. The opposite ovary is biopsied if it is enlarged. In premenopausal patients in whom conservative surgery is planned, preoperative evaluation of the uterus by hysteroscopy and endometrial aspiration is recommended to rule out a coexisting endometrial adenocarcinoma.

### Treatment of Borderline Tumours

The principal treatment of borderline ovarian tumours is surgical resection of the primary tumour. There is no evidence that either subsequent chemotherapy or radiation therapy improves survival. After a frozen section has determined that the histology is borderline, premenopausal patients who desire preservation of ovarian function may undergo a conservative operation, a unilateral oophorectomy. Recurrence was associated with positive margins of the removed ovarian cyst. Thus, hormonal function and fertility can be maintained. For patients in whom an oophorectomy or cystectomy has been performed and a borderline tumour is later documented in the permanent pathology, no additional immediate surgery is necessary.

#### *Stage I Low-grade, Low-risk*

For patients who have undergone a thorough staging laparotomy and for whom there is no evidence of spread beyond the ovary, abdominal hysterectomy and bilateral salpingo-oophorectomy are appropriate therapy. The uterus and the contralateral ovary can be preserved in women with stage IA, grade 1 to 2 disease who desire to preserve fertility. The conditions of the women should be monitored carefully with routine periodic pelvic examinations and determinations of serum CA-125 levels. Generally, the other ovary and the uterus are removed at the completion of childbearing. The Gynaecologic Oncology Group (GOG) carried out a prospective, randomised trial of observation versus melphalan for patients with stage IA and IB, grade 1 disease. Five-year

survival for each group was 94 and 96 per cent, respectively, confirming that no further treatment is needed for such patients.

#### *Stage I High-grade, High-risk*

For patients whose disease is more poorly differentiated or in whom there are malignant cells either in ascitic fluid or in peritoneal washings, complete surgical staging must be performed. The surgery should include the performance of a hysterectomy and bilateral salpingo-oophorectomy in addition to the staging laparotomy. Additional therapy is indicated, and although the optimal therapy for these patients is not known, most patients are treated with chemotherapy, as outlined below.

#### *Cytoreductive Surgery for Advanced-stage Disease*

Patients with advanced-stage epithelial ovarian cancer documented at initial exploratory laparotomy should undergo cytoreductive surgery to remove as much of the tumour and its metastases as possible. The operation to remove the primary tumour as well as the associated metastatic disease is referred to as debulking surgery. The operation typically includes the performance of a total abdominal hysterectomy and bilateral salpingo-oophorectomy, along with a complete omentectomy and resection of any metastatic lesions from the peritoneal surfaces or from the intestines. The pelvic tumour often directly involves the rectosigmoid colon, the terminal ileum, and the cecum. In a minority of patients, most or all of the disease is confined to the pelvic viscera and the omentum, so that removal of these organs will result in extirpation of all gross tumour, a situation that is associated with a reasonable chance of prolonged progression-free survival.

The removal of bulky tumour masses may reduce the volume of ascites present. Often, ascites will completely disappear after removal of the primary tumour and a large omental "cake." Also, removal of the omental cake often alleviates the nausea and early satiety that many patients experience. Removal of intestinal metastases may restore adequate intestinal function and lead to an improvement in the overall nutritional status of the patient, thereby facilitating the patient's ability to tolerate subsequent chemotherapy.

A large, bulky tumour may contain areas that are poorly vascularised, and such areas will be exposed to suboptimal concentrations of chemotherapeutic agents.

Similarly, these areas are poorly oxygenated, so that radiation therapy, which requires adequate oxygenation to achieve maximal cell kill, will be less effective. Thus, surgical removal of these bulky tumours may eliminate areas that are most likely to be relatively resistant to treatment.

In addition, larger tumour masses tend to be composed of a higher proportion of cells that are either nondividing or in the “resting” phase (i.e., G<sub>0</sub> cells, which are essentially resistant to the therapy). A low growth fraction is characteristic of bulky tumour masses, and cytoreductive surgery can result in smaller residual masses with a relatively higher growth fraction.

### Goals of Cytoreductive Surgery

The principal goal of cytoreductive surgery is removal of all of the primary cancer and, if possible, all metastatic disease. If resection of all metastases is not feasible, the goal is to reduce the tumour burden by resection of all individual tumours to an optimal status. The median survival of patients in this category was 40 months, compared with 18 months for patients whose lesions were <1.5 cm and 6 months for patients with nodules >1.5 cm. Patients whose disease has been completely resected to no macroscopic residual disease have the best overall survival.

The resectability of the metastatic tumour is usually determined by the location of the disease. Optimal cytoreduction is difficult to achieve in the presence of extensive disease on the diaphragm, in the parenchyma of the liver, along the base of the small-bowel mesentery, in the lesser omentum, or in the porta hepatis.

The ability of cytoreductive surgery to influence survival is limited by the extent of metastases before cytoreduction, presumably because of the presence of phenotypically resistant clones of cells in large metastatic masses. A patient whose metastatic tumour is very large (i.e., >10 cm before cytoreductive surgery) has a shorter survival than those with smaller areas of disease. Extensive carcinomatosis, the presence of ascites, poor tumour grade, even with lesions that measure <5 mm, may also shorten the survival.

### Exploration

The supine position on the operating table may be sufficient for surgical exploration of most patients. However, for those with extensive pelvic disease for whom a low resection of the colon may be necessary,

the low lithotomy position should be used. Debulking operations should be performed through a vertical incision to gain adequate access to the upper abdomen as well as to the pelvis.

After the peritoneal cavity is opened, ascitic fluid, if present, should be evacuated. In some centers, fluid is submitted routinely for appropriate *in vitro* research studies, such as molecular analyses. In cases of massive ascites, careful attention must be given to haemodynamic monitoring, especially for patients with borderline cardiovascular function.

### Pelvic Tumour Resection

The essential principle of removal of the pelvic tumour is to use the retroperitoneal approach. To accomplish this, the retroperitoneum is entered laterally, along the surface of the psoas muscles, which avoids the iliac vessels and the ureters. The procedure is initiated by division of the round ligaments bilaterally if the uterus is present. The peritoneal incision is extended cephalad, lateral to the ovarian vessels within the infundibulopelvic ligament, and caudally toward the bladder. With careful dissection, the retroperitoneal space is explored, and the ureter and pelvic vessels are identified. The pararectal and paravesicular spaces are identified and developed.

The peritoneum overlying the bladder is dissected to connect the peritoneal incisions anteriorly. The vesicouterine plane is identified, and with careful sharp dissection the bladder is mobilised from the anterior surface of the cervix. The ovarian vessels are isolated, doubly ligated, and divided.

Hysterectomy, which is often not a simple operation, is then performed. The ureters must be carefully displayed to avoid injury. During this procedure, the uterine vessels can be identified. The hysterectomy and resection of the contiguous tumour are completed by ligation of the uterine vessels and the remainder of the tissues within the cardinal ligaments.

Because epithelial ovarian cancers tend not to invade the lumina of the colon or bladder, it is usually feasible to resect pelvic tumours without having to resect portions of the lower colon or the urinary tract. However, if the disease surrounds the rectosigmoid colon and its mesentery, it may be necessary to remove that portion of the colon to clear the pelvic disease. This is justified if the patient will be left with optimal disease at the end of the cytoreduction. After the pararectal space is identified in such patients, the proximal site of colonic involvement is

identified, the colon and its mesentery are divided, and the rectosigmoid is removed along with the uterus en bloc. A reanastomosis of the colon is performed. It is rarely necessary to resect portions of the lower urinary tract. Resection of a small portion of the bladder may be required and, if so, a cystotomy should be performed to assist in resection of the disease.

### Omentectomy

Advanced epithelial ovarian cancer often completely replaces the omentum, forming an omental cake. This disease may be adherent to the parietal peritoneum of the anterior abdominal wall, making entry into the abdominal cavity difficult. After freeing the omentum from any adhesions to parietal peritoneum, adherent loops of small intestine are freed by sharp dissection. The omentum is then lifted and pulled gently in the cranial direction, exposing the attachment of the infracolic omentum to the transverse colon. The peritoneum is incised to open the appropriate plane, which is developed by sharp dissection along the serosa of the transverse colon. Small vessels are ligated with haemoclips. The omentum is then separated from the greater curvature of the stomach by ligation of the right and left gastroepiploic arteries and ligation of the short gastric arteries (Fig. 40.11).

The disease in the gastrocolic ligament can extend to the hilus of the spleen and splenic flexure of the colon on the left and to the capsule of the liver and the hepatic flexure of the colon on the right. Usually, the disease does not invade the parenchyma of the liver or spleen, and a plane can be found between the tumour and these organs. However, it will occasionally be necessary to perform splenectomy to remove all the omental disease.

### Radiotherapy

Radiotherapy now has a very small role, since platinum-based protocols and paclitaxel have improved the median survival. The dose of radiotherapy required to eradicate a tumour in the upper abdomen would not be tolerated safely by the liver or kidneys. High doses of irradiation would also produce gastrointestinal problems. Lesions greater than 2 cm in diameter cannot be destroyed without exceeding the tolerance of the small bowel.

However, it can be used as palliative treatment for metastatic bone or brain lesions or for localised recurrence to alleviate the pain. It has also been used successfully in

recurrent germ cell tumours especially dysgerminomas, which are very radiosensitive. This modality is not, however, usually preferred as it leads to loss of fertility.

Radioactive isotopes of gold (Au198) or phosphorus (P32) have been used intraperitoneally in combination with external radiotherapy. P32 is safer because it is a pure beta emitter without additional gamma radiation. It gives a high dose of radiation but only superficially to a depth of 4-6 mm. There is no improvement in survival rates but there is a high incidence of bowel complications.

Several monoclonal antibodies react with ovarian carcinoma antigens, e.g. AUA1, HMCG 1, HMFG 2, etc. Intraperitoneal radioactive monoclonal antibody therapy is under trial.

### Chemotherapy

Chemotherapy prolongs remission and survival and is also used for palliation in advanced and recurrent disease. It is administered postoperatively in all cases beyond Stage IA as soon as healing is complete. In epithelial ovarian cancers it is given for 5-6 cycles at 3-4-weekly intervals. Single agents were used initially and these included the alleviating agents chlorambucil, melphalan, cyclophosphamide, thiotepa and ifosfamide. Other drugs used include hexamethylmelamine, 5-fluorouracil, methotrexate, doxorubicin and etoposide. The platinum drugs, cisplatin and carboplatin, have also been used singly. Paclitaxel as a single agent has been tried in advanced cisplatin-resistant cancers.

Combination therapy is favoured nowadays. Although no clear-cut 5-year survival advantage has been demonstrated, better response rates have been achieved and median survival has improved. No chemotherapeutic substance kills all cancer cells in one treatment, and treatment therefore needs to be repeated several times to achieve a partial or complete cure. It is essential that all agents used should be active against the particular tumour. They should also have different modes of action to avoid drug resistance and should have different mechanisms for their toxic effects. This allows each of the active drugs to be used as near to the full dose as possible. Intermittent therapy allows maximum tumour cell killing and possibly less immunosuppression. The drugs are usually given at three-weekly intervals and various combinations have been tried. The standard accepted first-line drugs are cisplatin, doxorubicin and cyclophosphamide (CAP), although cisplatin and cyclophosphamide (CP) alone can also be used. Carboplatin can be

used instead of cisplatin. More recently, a combination of paclitaxel with cisplatin or carboplatin has shown better survival rates than conventional combination chemotherapy and it is the preferred first-line chemotherapy in many centres. However, cost factors may relegate its use to that of a second-line drug in developing countries.

Intraperitoneal chemotherapy has been tried in the past with thiotepa, but cisplatin and paclitaxel have shown better response rates.

In patients with proven advanced inoperable disease there may be a place for neoadjuvant chemotherapy. Three to four cycles of combination chemotherapy are administered before surgery. This reduces tumour bulk, ascites and pleural effusion, if any, and facilitates maximal cytoreduction. It also decreases the blood loss. However, dense adhesions between the uterus and adjacent organs are often encountered.

For non-epithelial tumours, combinations of vincristine, actinomycin D and cyclophosphamide (VAC) or vincristine, bleomycin and cisplatin (VBP) have been most commonly used. Presently bleomycin, etoposide and cisplatin (BEP) is the preferred combination, of which four courses are generally given. Patients retain their fertility subsequently and the babies have not shown any evidence of anomalies. The mechanism of action and common side-effects of chemotherapeutic drugs are discussed in Chapter 26. Table 33.2 shows some of the commonly used chemotherapeutic regimens.

Careful monitoring of the white blood cell and platelet counts is necessary to ensure that the bone marrow has not been too severely affected. Renal function is to be assessed if cis-platinum or its analogues are used.

### Follow-up

Follow-up is advised every 3-4 months for the first 2 years and then 6-monthly for 5 years. At each visit a general physical and pelvic examination is done along with estimation of serum CA-125 levels. Together they can detect 90 per cent of recurrences. Radiological procedures need to be individualised.

#### *Second-look Laparotomy (SLL)*

Following response, and in the absence of palpable or identifiable disease by CT scan, MRI or CA-125, a second-look operation may be undertaken in patients with Stages III and IV disease to determine whether the patient is a candidate for removal of any remaining cancer, continued

**Table 33.2 Chemotherapeutic regimens in ovarian cancer**

	<i>Regimen</i>	<i>Dose</i>
CP	Cisplatin	75 mg/m <sup>2</sup>
	Paclitaxel	135-175 mg/m <sup>2</sup>
CT	Carboplatin	AUC = 5
	Paclitaxel	135-175 mg/m <sup>2</sup>
PC	Cisplatin	75 mg/m <sup>2</sup>
	Cyclophosphamide	750 mg/m <sup>2</sup>
CAP	Cyclophosphamide	600 mg/m <sup>2</sup>
	Doxorubicin	50 mg/m <sup>2</sup>
BEP	Cisplatin	75 mg/m <sup>2</sup>
	Bleomycin	10 mg/m <sup>2</sup> x 3 days
	Etoposide	20 mg/m <sup>2</sup> x 5 days
	Cisplatin	100 mg/m <sup>2</sup>

AUC = Area under curve

*Note: All regimens administered at 3-weekly intervals*

chemotherapy, or a change of chemotherapeutic agents. A raised CA-125 level predicts persistent disease at SLL in 97 per cent of cases but is not specific enough to exclude subclinical disease. CT scan does not detect lesions less than 2 cm in size. Commonly, areas of fibrosis and matted bowel or omentum may be mistaken for persistent disease.

The surgical procedure is the same as for staging but biopsies must especially be taken from suspicious looking areas, sites reported to have residual tumour, primary surgery and adhesions. SLL has not improved survival rates but is a good prognostic indicator. If secondary debulking can be done to reduce residual tumour size to less than 0.5 cm, median survival improves. The additional morbidity and cost have to be weighed against expected benefit.

### Results

The results of surgery for benign tumours are, of course, good. For malignant tumours they vary with a host of factors such as cell type and activity, the extent of growth, the involvement of peritoneum, omentum and other tissues and, most importantly, the amount of residual disease. According to such considerations, the 5-year survival rates vary from 80 to 100 per cent in Stages I and II, 30-40 per cent in Stage IIIA, 20 per cent in Stage III B and <5 per cent in Stages IIIC and IV.

Reported figures indicate that results depend more on the stage of the growth than on its histological grade. In grade I tumours overall 5-year survival rate is 40 per cent, in grade 2 it is 20 per cent and in grade 3 it is 5-10 per cent.

In borderline ovarian tumours the 10- and 20-year survival rates are 95 and 90 per cent, respectively.

Improved results are obtained with routine chemotherapy as a supplement to proper staging and radical surgery for malignant disease of the ovary. *Spontaneous regression* or slowing down of growth does occur and women given a short expectation of life can sometimes survive in comfort for years without treatment.

### Metastatic (Secondary) Ovarian Tumours

The ovary is a common site for metastases, usually carcinomatous, sometimes lymphoma, occasionally carcinoma. This is because of its vascular and lymphatic connections rather than the possession of a mysterious attraction for cancer cells. Approximately 5 per cent of all malignant growths found in the ovary during life are secondary to a primary lesion elsewhere. Autopsy examination of cancer subjects reveals an even higher incidence. For example, 20 to 25 per cent of women dying from cancer of the breast have secondaries in the ovaries and 80 per cent are bilateral. Ovarian deposits are most likely in relatively youthful victims of cancer, between the ages of 35 and 50 years.

### Carcinoma

#### Origin

The commonest sites for the primary carcinoma are the stomach, colon, breast, uterus, fallopian tube and the opposite ovary. The breast is the most frequent. In the case of a primary ovarian tumour, there is some dispute as to whether the contralateral tumour is metastatic or whether it is another primary focus. Ovarian metastases can be found several years after apparent cure of breast carcinoma, and also in patients whose primary growth in the alimentary tract is so small that it escapes recognition even at laparotomy. The rare melanoma of the ovary can be metastatic but more often arises *de novo* in a teratoma.

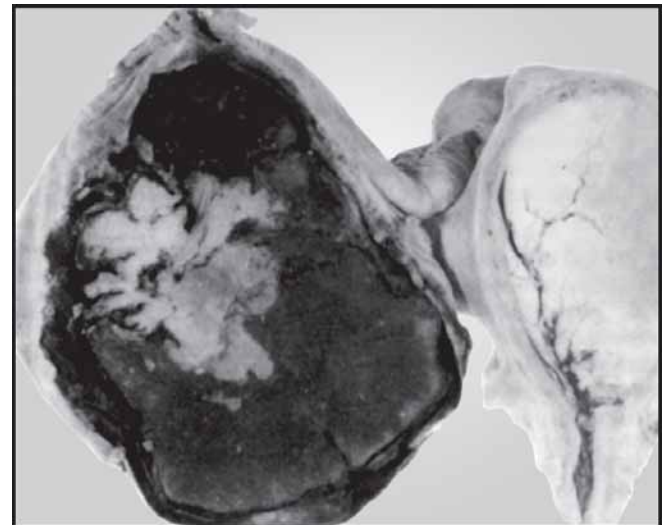
Although the ovary can become involved by direct extension of growth from an adjacent organ, cancer cells ordinarily travel to it by way of blood vessels or lymphatics, the mechanism being embolism or permeation, sometimes retrograde, and by transcoelomic spread. From the breast the cancer cells travel to the mediastinal, and thence to the aortic and para-aortic nodes; from the stomach they go direct to the latter. The lymphatics accompanying the ovarian vessels then offer a direct route from the aortic

region to the hilum of the ovary. From the body of the uterus, cancer cells may travel along the lumina of the tubes to spill on the ovaries, but a lymph or bloodstream spread is the more likely mechanism (Fig. 33.26).

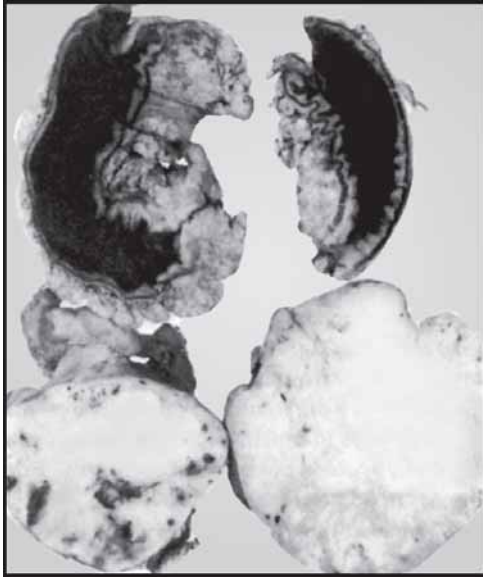
#### Pathology

Metastatic cancers are nearly always bilateral and rarely exceed a foetal head in size; even so they are often larger than the primary lesion. Their surface is usually smooth, lobulated and free from adhesions (Fig. 33.27). They are essentially solid with a waxy consistency but may contain degenerative cystic spaces. Microscopically they show islands of malignant cells morphologically similar to those in the primary growth and scattered throughout the ovary as multiple foci.

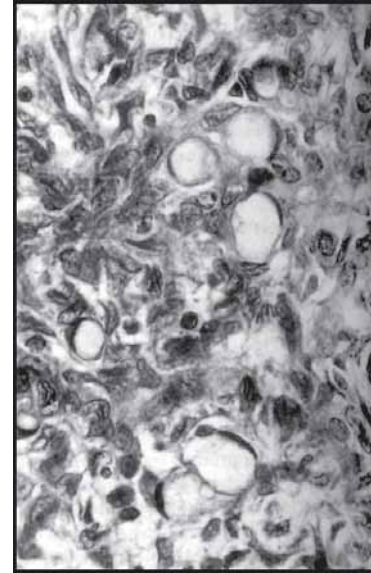
A well-known growth with special histological features is the Krukenberg tumour which can account for 30 to 40 per cent of metastatic cancer. It consists of clumps and cords of epithelial cells in a proliferating stroma, the two types of tissue being responsible for the growth being originally described as a carcinosarcoma. The epithelial cells secrete mucin which mostly remains within their cytoplasm to give them a bloated appearance and an eccentric nucleus - *signet ring cells* (Fig. 33.28). The mucin sometimes escapes into the stroma and in both sites is readily demonstrated by differential staining. The primary growth is always in mucin-secreting tissue, usually the stomach or colon but sometimes the gall bladder or breast.



**Fig. 33.26:** Carcinoma of the body of the uterus associated with a haemorrhagic carcinoma of the ovary. The histology of the two growths is similar and in such a case it is difficult to say which is primary, or whether the two are independent



**Fig. 33.27:** Carcinoma of the colon with metastases in both ovaries. The homogeneous waxy appearance of the cut surface is a feature of many secondaries in the ovaries



**Fig. 33.28:** Ovarian Krukenberg tumour. Several large cells with clear, vacuolated cytoplasm and peripheral crescentic nuclei are present in this section: they are the signet rings which are typical of Krukenberg tumour of the ovary. In this case the primary tumour was in the stomach. (Photomicrograph x750)

In some cases, a primary tumour is not found. Rarely, it may be in the cervix or bladder.

A woman has a 1-in-70 risk of developing ovarian cancer in her lifetime. The incidence is 1.4 per 1 00 000 women under age 40, increasing to approximately 45 per 100,000 for women over age 60. A higher incidence of ovarian cancer is seen in women who have never been pregnant or who are of low parity. Women who have had either breast or colon cancer or have a family history of these cancers also are at higher risk of developing ovarian cancer. Protective factors include multiparity, contraceptive use, a history of breastfeeding, and anovulatory disorders.

#### *BRCA1 and BRCA2*

Most hereditary ovarian cancer is associated with mutations in the BRCA1 gene, located on chromosome 17. A small proportion of inherited disease has been traced to another gene, BRCA2, located on chromosome 13. These two genes are associated with the genetic predisposition to both ovarian and breast cancer. In addition, there is a higher-than-expected risk of ovarian and endometrial cancer in the Lynch II syndrome, known also as the hereditary nonpolyposis colorectal cancer syndrome (HNPCC syndrome).

*Screening.* There is no proven method of screening for ovarian cancer. Routine screening by abdominal or vaginal ultrasound or measurement of CA-125 levels in serum cannot be recommended for women with no known risk factors. For women with familial ovarian cancer syndrome who wish to maintain their reproductive capacity, transvaginal ultrasonography, analysis of levels of CA-125 in serum, or both, in combination with frequent pelvic examinations may be considered.

Current recommendations for management of women at high risk for ovarian cancer are as follows:

Women who appear to be at high risk for ovarian or breast cancer should undergo genetic counseling and, if the risk appears to be substantial, may be offered genetic testing for BRCA1 and BRCA2.

Women who wish to preserve their reproductive capacity can undergo screening by transvaginal ultrasonography frequently every 6 to 12 months, although the efficacy of this approach is not clearly established.

In women who also have a strong family history of breast cancer, annual mammographic screening should be performed beginning at age of 30 years.

Women with a documented HNPCC syndrome should undergo periodic screening mammography, colonoscopy, and endometrial biopsy.



### *Lynch II Syndrome*

This syndrome, which includes multiple adenocarcinomas, involves a combination of familial colon cancer (known as the Lynch I syndrome), a high rate of ovarian, endometrial, and breast cancers, and other malignancies of the gastrointestinal and genitourinary systems.

#### **Treatment**

This is ordinarily directed to the primary cancer but, if this can be excised and if there are no metastases apparent in other sites, it is worthwhile removing the affected ovaries as well. Chemotherapy can follow.

### **Leukaemia and Lymphoma**

#### *Origin and Pathology*

Secondary deposits in the ovary can arise in women suffering from one of the leukaemias or lymphoma. This is most commonly seen in Hodgkin's disease and Burkitt's lymphoma. With other lymphomas, ovarian involvement is much rarer and with leukaemias it is extremely infrequent.

#### *Treatment*

Treatment is essentially that of the lymphoma or leukaemia by chemotherapy. Sometimes the ovary may be the only site of disease and then a laparotomy may be required to establish the diagnosis. In such cases, the tumour mass may be resected. Removal of large masses may improve the response to subsequent chemotherapy and provide symptomatic relief.

#### *Carcinoid Tumours*

Although carcinoid tumours account for less than 2 per cent of ovarian metastatic tumours, it is important to remove the ovaries in peri- and postmenopausal women being operated for intestinal carcinoid. Conversely, the finding of an ovarian carcinoid tumour should be followed by a meticulous search for a primary intestinal carcinoid.

### **Tumours of the Ovary Associated with Carcinoma of the Body of the Uterus**

This not uncommon association is accounted for in the following possible ways:

- A primary growth in the endometrium with a metastasis in the ovary or vice versa. In these cases the

growths are identical in appearance and the spread is by lymphatics or by transtubal seeding (Fig. 33.26).

- A thecoma or granulosa cell tumour of the ovary stimulating the endometrium to malignant activity by its excessive or unopposed production of oestrogen.
- A simultaneous but unrelated development of two separate growths, the phenomenon possibly illustrating the multifocal origin of cancer or at least a widespread tendency to neoplasia in many tissues.

The following case illustrates the third possibility. A parous woman had a carcinoma of the colon removed at the age of 30 years. Four years later she required right hemicolectomy for a carcinoma of the caecum which was regarded as an unrelated growth with different histological characters. When the patient was aged 45 years, she had a total hysterectomy and bilateral salpingo-oophorectomy for a large mucinous cystadenocarcinoma of the left ovary. Examination of the specimen showed the tumour to be a primary growth and revealed, moreover, an early symptomless endometrial carcinoma with differing microscopic appearances. This patient developed four separate primary cancers within 15 years. She remained alive and well 15 years later. Meanwhile, every one of her female relatives died from cancer in some site.

The treatment of combined pelvic tumours is generally by total hysterectomy and bilateral salpingo-oophorectomy, omentectomy, biopsy of the peritoneum and analysis of peritoneal washings, supplemented with chemotherapeutic or radiotherapy agents, as the situation appears to indicate.

## **OVARIAN AND PAROVARIAN TUMOURS AND PREGNANCY**

### **Pathology**

The commonest types of 'ovarian tumour' encountered in pregnancy are the cystic teratoma, parovarian cyst, serous cystadenoma, cystic corpus luteum of pregnancy, and fibroma. They are more easily discovered in the early months for, when the uterus becomes large, the ovarian mass is pushed behind it or into one flank. The corpus luteum cyst in any case disappears by the twelfth to the sixteenth week. Often the cyst is detected incidentally on routine ultrasonography.

As the pregnancy advances the tumour is usually lifted into the abdomen and does not necessarily interfere with either pregnancy or labour. On the other hand, the following complications are not uncommon: torsion of the pedicle of the tumour during pregnancy and the puerperium (Fig. 33.24); impaction of the tumour in the pelvis to cause retention of urine during pregnancy and obstruction of labour; malpresentation of the foetus; rupture of the cyst during pregnancy or labour; the tumour may be malignant or may become malignant during pregnancy.

### Differential Diagnosis

The conditions most likely to be confused with an ovarian or parovarian tumour during pregnancy are: uterine leiomyomas; the non-pregnant horn of a bicornuate uterus—this contracts intermittently; a pelvic kidney; a retroperitoneal tumour; an ectopic pregnancy; and a retroverted gravid uterus.

If the patient is examined in the Trendelenburg position, all these conditions remain in the pelvis whereas an ovarian tumour tends to ride out and become obviously separate from the uterus (Hingorani sign).

### Treatment

#### *A Tumour Less Than 10 cm in Diameter and not Solid*

If the cyst appears benign on ultrasound, it is generally treated conservatively. It is usually a corpus luteum and commonly disappears spontaneously. If it has not resolved 6 weeks postpartum, surgery may be considered.

#### *A Tumour Found in the First 3 Months of Pregnancy*

Such a tumour is not usually removed at once. It is better to wait until the sixteenth week when implantation of the pregnancy is more secure. Moreover, by this time, a cystic tumour sometimes disappears; if it does, it means that it was a corpus luteum cyst. Persisting tumours are treated by cystectomy or ovariectomy as the circumstances dictate. The risk of abortion following such operations, even when they are performed in the early weeks of pregnancy, is very small. If the corpus luteum has to be removed as well it is of no consequence; indeed,

both ovaries can be removed without harm to the conception.

#### *A Tumour Found after the Twenty-eighth Week of Pregnancy*

An ovarian tumour can be removed easily and safely until the twenty-eighth to the thirtieth weeks of pregnancy. Thereafter it is not readily accessible and its removal may precipitate premature labour. The patient whose pregnancy is far advanced should therefore merely be kept under observation and allowed to deliver normally, the tumour being preferably removed during the first week of the puerperium.

#### *A Tumour Obstructing Labour*

The best treatment here is to deliver the child by lower-segment caesarean section and to remove the tumour before closing the abdomen. Attempts to dislodge the tumour from the pelvis by posture and by vaginal manipulation are not advised; they nearly always fail and they involve risk of injury to the tumour or other structures.

#### *A Tumour Which is Complicated*

An ovarian cyst which ruptures, undergoes torsion of the pedicle, or one which shows evidence of malignancy, requires immediate surgery irrespective of the period of pregnancy. Before undertaking surgery in a pregnant woman with an ovarian (or adnexal) mass, the possible options should be explained to the patient. Ovarian cancer is seen in less than 3 per cent of ovarian cysts in pregnancy. Ultrasound helps to assess malignancy. Assessment of CA-125 levels is not useful because it is elevated in pregnancy. The survival of patients with ovarian cancer in pregnancy is no different from survival in non-pregnant ones. The type of tumour and its spread determine the 5-year cure rate. Pregnancy has no effect on the tumour and termination of the pregnancy at any period of gestation has no beneficial effect on the outcome. Stage IA tumours can be treated by ovariectomy in early pregnancy followed by completion of surgery at term, provided the patient understands the implications. Caesarean hysterectomy, bilateral salpingo-oophorectomy and omentectomy is the generally preferred plan of management.

# CHAPTER 34

## Chemotherapy in Gynaecological Malignancies

Clinical Use of Chemotherapy	562	Chemotherapy Resistance of Cancer Cells	566
Assessment of Response to Chemotherapy	562	Poor Host Defenses	566
Chemotherapy and the Cell Cycle	562	Protected Tumour Sanctuaries	566
Cell-Kill Hypothesis	563	Route of Administration	567
Therapeutic Agents Used in the treatment of Gynaecological Cancer	564		

### INTRODUCTION

Long-lasting remissions and occasional cures for several types of cancer have been achieved with antitumour drugs. For example, up to 90 per cent of patients with metastatic choriocarcinoma achieve a normal life expectancy, and almost 100 per cent of those without metastases are cured now that the effect of drugs may be monitored by the level of  $\beta$ -hCG (human chorionic gonadotropin), which provides a reliable index of tumour growth. For most tumours, however, no such specific and sensitive assay or tumour marker exists. Now that multiple-drug regimens are being used for primary chemotherapy of carcinoma of the ovary, objective response rates of 60–80 per cent are achieved. The objective response rate of 20–40 per cent achieved by chemotherapy in patients with primary carcinoma of the breast and endometrium warrants the use of chemotherapy as an integral part of an initial treatment program.

In spite of extensive experience, the use of cytotoxic agents for carcinomas of the cervix, vagina, and vulva is still on a clinical trial basis, since these tumours usually grow more slowly, and cytotoxic drug treatment has been palliative but not curative; these types of cancer are better controlled by surgery and radiation therapy, and chemotherapy should be considered only when these standard methods have proved ineffective.

Among the uncommon gynaecologic cancers that may require chemotherapy are germ cell tumours of the ovary and primary ovarian, uterine, vaginal, or vulvar sarcomas. Because these tumours are rare, little is known about their sensitivity to antitumour drugs.

Chemotherapy is a systemic treatment and can treat distant metastasis. The only gynaecological tumour with high cure rates from chemotherapy is choriocarcinoma. A minority of cases of ovarian cancer are cured by chemotherapy, but the main role of treatment in most cases is only palliative therapy. Five-year

survival with optimal treatment of patients with stage III ovarian cancer (the most common stage at presentation) is only 20-30 per cent but the median survival has been increased by 2-3 years. Currently employed chemotherapeutic agents are cytotoxic and act to a greater or lesser extent on normal tissue as well as malignant cells. To produce optimal results, chemotherapeutic agents must be given in the highest tolerable doses. There is only a thin line between the maximum therapeutic effect upon the tumour and ill effects on the patient.

### CLINICAL USE OF CHEMOTHERAPY

Chemotherapy may be used as the sole method of treating the patient or as adjuvant or neo-adjuvant treatment in combination with other treatment modalities such as surgery or radiotherapy. The most common use for chemotherapy is the treatment of clinically obvious disseminated disease. A common example is the treatment of patients with inoperable ovarian cancer. Adjuvant chemotherapy is used to treat occult disease. Such patients have no detectable disease following surgery, but clinical experience has shown that without additional treatment, a considerable proportion of such patients will eventually develop distant metastasis. Neo-adjuvant treatment is when chemotherapy is given prior to definitive treatment using surgery or radiotherapy to the primary cancer. By and large, neo-adjuvant chemotherapy in the treatment of cervical carcinoma has not been successful prior to radiotherapy, although there may be a survival advantage if chemotherapy is given prior to surgery. By contrast, chemotherapy combined with radiotherapy seems to improve survival, thus improving cure rates and reducing the chance of local and distant recurrence. A Cochrane meta-analysis of all available trials in 2001 showed that chemotherapy combined with radical radiotherapy reduced the chance of death by 29 per cent in locally advanced cervical cancer compared with treatment by radiotherapy alone.

### ASSESSMENT OF RESPONSE TO CHEMOTHERAPY

In order to cure any patient with chemotherapy, there needs to be a complete response to treatment. This is seen as disappearance of all measurable or evaluable disease, signs, symptoms and biochemical changes

related to the tumour for at least 4 weeks. Partial response is taken when there is a reduction of greater than 50 per cent of the original mass in four weeks. Typical response rates for elective chemotherapy regimens such as full-dose carboplatin or carboplatin and paclitaxel in ovarian cancer are 60-70 per cent. The smallest detectable tumour measuring 1 cm<sup>3</sup> contains about 1000 000 000 (10<sup>9</sup>) cancer cells. Not all of these cells are viable and it is the clonogenic cell component that must be sterilised. If there was initially 10<sup>11</sup> cells, 10<sup>6</sup> cells will remain. A million cancer cells may be clinically undetectable but, in time, this tumour will re-grow. In some cases, however, all of the clonogenic cells are sterilised, resulting in a clinical cure.

### CHEMOTHERAPY AND THE CELL CYCLE

Cell cycle time denotes the amount of time needed by a proliferating cell to progress through the cell cycle and produce a new daughter cell. Cell cycle times vary widely according to histologic type (18-217 hours in solid tumours) but are relatively constant for a specific tumour type. Doubling time is the time required for the tumour cell population to double. Human tumours often have doubling times greater than those of comparable normal tissues and, in advanced stages of disease, may exhibit a range of doubling times, but 30-60 days is typical. In the model ascites system, cell doubling time remains constant at nearly 100 per cent throughout almost the entire life cycle of the tumour, whereas in solid tumour systems, a gradual slowing of the tumour doubling time and reduction of the proliferation rate of cells occur with tumour enlargement as a result of decreased accessibility to nutrients. Cell loss may be a major determinant of the tumour growth rate. Cells are lost from a tumour mass in various ways, including death, migration, or metastases. Cell loss is frequently high in advanced tumours.

Cancer cells do not divide faster than their normal tissue equivalent. However, there are usually more cells dividing in a tumour than within normal tissues. The number of dividing cells is referred to as the growth fraction and, exceptionally, this can approach 100 per cent in rapidly growing tumours such as Burkitt's lymphoma. By contrast, in some slow-growing tumours such as some breast and colon cancers, the growth fraction is less than 20 per cent. Actively proliferating cells are the most vulnerable to chemotherapy.

Non-dividing cells are killed less by anticancer drugs.

## Stem Cell Theory

The stem cell theory states that only certain relatively undifferentiated cells, or stem cells, of a particular tissue type are able to divide and reproduce the entire tissue. Examples include rapidly proliferating tissues such as bone marrow, the lining of the gastrointestinal tract, and the basal cell layer of the skin. In other words, most cells making up a particular tissue have matured or have become highly differentiated after clonal division from the reproducing cell or a specific stem cell.

Not all cells of a particular stem cell population are committed to division at a given time. A significant proportion of stem cells are in the G<sub>0</sub> or resting phase, as is the case in normal bone marrow, in which at any one time from 15–50 per cent of stem cells are in G<sub>0</sub>. Numerous stimuli may recruit this reserve (resting) population of stem cells into the cell cycle. The equilibrium between the number of cells in division and those at rest, and the requirement for controls on such growth, are important. Some of the controls are understood, whereas others are unknown.

The stem cell theory also describes neoplastic growth. The clonality of many tumours such as epithelial ovarian cancer suggests that tumours originate from single stem cells. Therefore, tumours may consist of a small percentage of stem cells that due to failed growth control mechanisms continuously provide malignant cells. Based on this assumption, any therapeutic intervention should target this stem cell population to avoid recurrences.

## CELL-KILL HYPOTHESIS

The fundamental kinetic consideration in cancer chemotherapy is the cell-kill hypothesis, which states that the effects of cancer chemotherapy on tumour cell populations demonstrate first-order kinetics; i.e. the proportion of tumour cells killed is a constant percentage of the total number of cells present. In other words, chemotherapy kills a constant proportion of cells, not a constant number of cells. The number of cells killed by a particular agent or combination of drugs is proportional to one variable: the dose used. The relative sensitivity of cells is not considered, and the growth rate is assumed to be constant.

Since chemotherapy follows an exponential (log-kill) model, treatment may be said to have a specific exponential, or log-kill, potential. For example, a log kill

of 2 reduces a theoretical human tumour burden of  $10^9$  cells to  $10^7$  cells. Although this represents a reduction of 99 per cent, at least 10 million ( $10^7$ ) viable cells remain. A log kill of 3 achieves a reduction of 99.9 per cent, but 1 million ( $10^6$ ) cells remain. Theoretically, therefore, such fractional reductions by antineoplastic agents can never reduce a tumour cell population to zero. This traditional cell-kill model is based mainly on exponentially growing tumours in laboratory models, e.g. L-1210 murine leukaemia. Although the cell-kill hypothesis probably explains some aspects of drug selectivity, other mechanisms are involved. The more responsive tumours are those with large growth fractions. Normal tissue can withstand greater cell loss due to chemotherapy than can tumours, although the proportion killed in both systems may be identical.

Another theory states that clinical tumour regression as a result of chemotherapy is best explained by the relative growth fraction in the tumour at the time of treatment. Thus very small and very large tumours are less responsive than those of intermediate size, which have the biggest growth fraction. Therefore, log kills occur only at times of maximal tumour growth fraction. Although this hypothesis has not been directly confirmed clinically, it explains some clinical observations of responses to chemotherapy in large and small human tumours.

The cycle is divided into four main phases (Fig. 34.1). G<sub>1</sub> is the protein synthetic phase. In the S phase, DNA is copied and synthesised prior to cell division, which occurs following chromosome condensation and

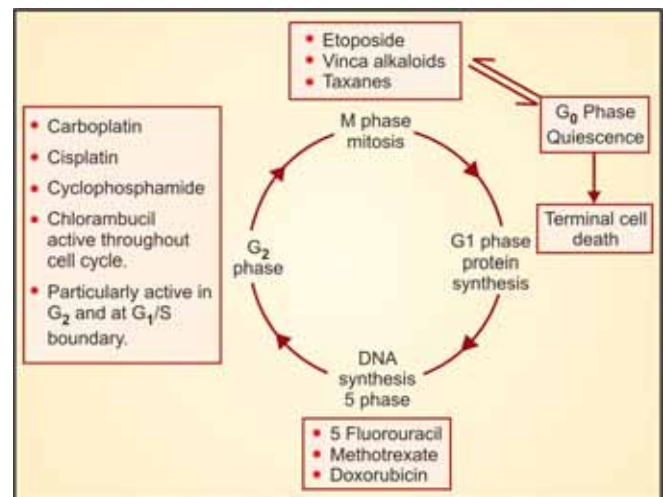


Fig. 34.1: Chemotherapy and the cell cycle

segregation in the G2 and M phases. The so called resting phase, G0, is important. Such cells are not undergoing cell division and may eventually get into programmed cell death (apoptosis). However, following treatment with chemotherapy or radiotherapy, some G0 cells may be recruited back into the cycle. The lethal effects of chemotherapeutic agents vary between different phases of the cell cycle (Fig. 34.1). Cisplatin, carboplatin and the alkylating agents are lethal throughout the cell cycle but are particularly active in G2 and at the G1/S boundary. Antimetabolites such as 5-FU and methotrexate are most active against cells in the S phase. Etoposide, vinca alkaloids and taxanes are most effective against cells in the G2/M phases of the cell cycle.

Therapy must also take into account the length of time a therapeutic concentration of drug is maintained. The maximal effectiveness of some oncolytic drugs depends mainly on peak tissue concentration, whereas that of others depends on the duration of exposure.

In principle, a therapeutic concentration of the cell cycle (phase)-specific drugs is best maintained by 5-day courses of treatment (about 2 average cell generation times). Such prolonged exposure permits a higher fraction of proliferating cells to pass through vulnerable phases of the cell cycle, since proliferating cells do not progress through the cell cycle in a synchronised fashion. In contrast, the cell cycle (phase)-nonspecific drugs are best administered as an intravenous bolus of the highest tolerable dose, and the dose repeated when normal target tissues have recovered.

High-dose, intermittent therapy has been the most successful schedule against tumours with a large growth fraction. Slow-growing tumours have a large component of permanently nondividing cells and a small growth fraction. Theoretically, drugs active against cells in G0 and given on a continuous basis should produce the best results in these tumours.

Chronic therapy is feasible only if toxicity is negligible. Some myelosuppression is acceptable, since recovery occurs between treatment cycles. Immunosuppression is a side effect of most cytotoxic drugs and is more pronounced when drugs are given continuously.

Antitumour drugs have been combined concurrently or sequentially in an effort to increase their effectiveness. It is logical to assume that drugs with different dose-limiting toxicities and different modes of action may increase the fractional cell kill without a parallel rise in damage to normal tissues and immunocompetent cells.

Since tumours are composed of numerous cell clones that vary in their sensitivity to drugs, the use of multiple agents should lessen the chance of development of resistance and repopulation of the tumour by a resistant cell clone. Sequential, concomitant, or complementary blockade of metabolic pathways should avoid the problem of drug resistance secondary either to the utilisation of alternative pathways or the emergence of a protective random mutation.

As a rule, drugs selected for multidrug therapy must be effective as single agents if improved results are to be expected. Unfortunately, the toxicities of most antitumour drugs are similar, and selecting drugs that have no overlapping side effects is usually not possible. Nevertheless, combination chemotherapy has proved superior to single-agent therapy in leukaemia, lymphoma, and some rapidly proliferating solid tumours including ovarian cancer.

## THERAPEUTIC AGENTS USED IN THE TREATMENT OF GYNAECOLOGICAL CANCER

### Alkylating Agents

DNA replication is inhibited by this group of drugs by the drug forming covalent bonds with DNA bases. Some are bifunctional and react with two strands of DNA to produce cross-linkage. The role of alkylating agents in the treatment of gynaecological cancer has diminished in the last 10 years. There are a number of alkylating agents available with varying toxicity. Chlorambucil is the least toxic and can be given by mouth. This drug still has a limited role in the treatment of frail patients with ovarian cancer. Cyclophosphamide and ifosfamide have activity against ovarian cancer and squamous carcinomas of the cervix and the vulva. Both produce an acrolein metabolite, which can cause haemorrhagic cystitis.

### Cisplatin and Carboplatin

These drugs are probably the most important chemotherapeutic agents in the treatment of gynaecological cancer at present. Platinum compounds form DNA cross-links by an action similar to the bifunctional alkylating agents. The DNA lesions produced are frequent and difficult to repair. Cisplatin is the most active agent in the treatment of cervical cancer and is particularly useful in conjunction with radiotherapy. The toxicity of this drug limits its clinical usefulness and there are now a

number of less-toxic analogues, particularly carboplatin. This is the most useful drug in the treatment of ovarian cancer and can even be tolerated by elderly patients.

### Antimetabolites

Methotrexate is an antifolate and its major biochemical action is to block the enzyme dihydrofolate reductase, leading to inhibition of DNA and RNA synthesis. The toxicity of methotrexate can be inhibited by the timely administration of folinic acid. Currently, methotrexate has a limited role in the treatment of gynaecological squamous cancer but is used extensively in the adjuvant treatment of breast cancer, along with the antimetabolite 5FU and the alkylating agent cyclophosphamide in the CMF regimen. Methotrexate is very useful in persistent trophoblastic tumours. 5-FU acts against the enzyme thymidylate synthetase and can be incorporated into RNA and DNA, directly leading to inhibition of nucleic acid production. 5-FU has some single-agent activity against ovarian cancer but is mainly used in the treatment of colorectal cancer, particularly in combination with folinic acid.

### Antitumour Antibiotics

The most important members of this drug class are anthracyclines, doxorubicin (Adriamycin) and epirubicin. Anthracyclines inhibit DNA synthesis through a complex series of actions. Amongst the cytotoxics, the anthracyclines have one of the widest spectra of activity. They are used extensively in the treatment of breast cancer and uterine sarcomas. Doxorubicin is also active against ovarian cancer. Bleomycin can produce strand breaks in both the DNA of the nucleus and the mitochondria, and is most commonly used in the treatment of germ-cell tumours and malignant pleural infusions. Vinca alkaloids (vincristine and vinblastine) are extracted from the periwinkle and act against the mitotic spindle. They are used in the treatment of a wide variety of malignancies. Clinically, etoposide is the most important podophyllotoxin, with high activity against germ-cell tumours and some sarcomas. It is given orally as second-line therapy for ovarian tumours.

### Taxanes

The taxane group are extracted from the yew tree. Paclitaxel is isolated from the bark of the Western yew tree and docetaxel is derived from the needles of the

European yew tree. Both drugs act against microtubules to induce a sustained block in mitosis. Both paclitaxel and docetaxel have equal activity in the treatment of ovarian cancer, but have different patterns of toxicity.

### Chemotherapy Toxicity

Unfortunately, chemotherapeutic agents act upon normal cells as well as malignant tissue. The pattern of toxicity varies between different drugs and even between different members of the same drug class.

#### *Bone Marrow Suppression*

Many chemotherapeutic agents affect the rapidly dividing cells in the bone marrow, leading to temporary bone marrow suppression. Lowest white cell and platelet counts (Nadir values) are usually seen 10 days after treatment with alkylating agents or anthracyclines. Interestingly, the addition of paclitaxel to carboplatin reduces the degree of thrombocytopenia. The Nadir count after carboplatin is usually seen 15-18 days after treatment. Cisplatin is considerably less myelosuppressive than carboplatin but long-term use can lead to anaemia. The vinca alkaloids and bleomycin are particularly non-myelosuppressive.

#### *Nausea and Vomiting*

The vast majority of patients receiving carboplatin chemotherapy for ovarian cancer have no nausea or vomiting. Cisplatin, doxorubicin and ifosfamide are amongst the most emetogenic drugs, although emesis can be prevented in most cases.

#### *Alopecia*

Temporary hair loss is a side effect of cyclophosphamide, doxorubicin, etoposide and the taxanes. Carboplatin and cisplatin chemotherapy are not usually associated with hair loss. Hair loss can be reduced by scalp cooling, although this is only elective in drugs with a relatively short half-life such as doxorubicin, as patients cannot tolerate the cooling devices for longer than about 1 hour.

#### *Renal Toxicity*

Both methotrexate and cisplatin can cause severe damage to the renal tubules. Renal damage can be largely prevented during cisplatin administration by adequate

pre- and post-chemotherapy hydration with saline. A small number of patients treated with cisplatin develop hypomagnesaemia. This usually recovers within 1 month of stopping treatment. Carboplatin does not normally affect the kidneys.

#### *Cardiotoxicity*

Doxorubicin can cause a cardiomyopathy leading to conduction problems in the heart and congestive cardiac failure. This is not usually seen until the cumulative dose of doxorubicin approaches 450-550 mg/m<sup>2</sup>. The doxorubicin analogue, epirubicin, is less cardiotoxic.

### **CHEMOTHERAPY RESISTANCE OF CANCER CELLS**

One of the major problems in the treatment of cancers with chemotherapeutic agents is the development of drug resistance. According to the Goldie-Coldman hypothesis, most mammalian cells start with intrinsic sensitivity to antineoplastic agents but subsequently develop resistance at variable rates. This model has important clinical implications; tumours are only curable if no resistant cell lines are present or develop during the course of chemotherapy. To minimise the development of drug resistance, multiple drug regimens are preferred to single drug therapies.

Development of resistance is mainly based on the occurrence of spontaneous mutations which occur at a frequency of 1 in 10,000 to 1 in 1,000,000 cells. Mechanisms of drug resistance involve decreased cellular uptake or increased efflux of the chemotherapeutic agents via cellular pumps, decrease in drug activation, increase in drug degradation, inactivation of active metabolites by binding to sulphhydryl compounds, increase in DNA repair mechanisms, or increase in level of target enzyme (dihydrofolate reductase). Several genes have been implicated in drug resistance, e.g. the multiple drug resistance (MDR) gene. Gene therapy approaches are currently being studied to reverse drug resistance in tumour cells. Alternatively, the transfer of drug resistance genes into normal cells like bone marrow cells might confer increased protection to chemotherapeutic agents and possibly allow a dose increase.

### **POOR HOST DEFENCES**

The normal individual's immunologic defences against an invading tumour cell population are unreliable and

still poorly understood. They operate only if the tumour mass is relatively small, and they become less effective as the person ages. As tumour growth progresses, the body's diminishing immunocompetence compounds the difficulties of therapy. A complicating factor is the immunosuppressant properties of most antitumour drugs. Treatment schedules to minimise immunosuppression while permitting adequate therapeutic effectiveness should be more intensive but actually must be practiced sparingly because of the lack of antitumour selectivity. Current studies are attempting to enhance immunologic host defenses by immunostimulation with reagents such as bacille Calmette-Guérin (BCG) or *Corynebacterium parvum* and by restoration of immunocompetence with agents such as levamisole, thymosin, or interferon, as well as with combinations of two or more kinds of immunotherapy. Cyclophosphamide at low doses can stimulate CD4+ helper cells and has been used in clinical immunotherapy trials in conjunction with immunostimulatory cytokines.

### **PROTECTED TUMOUR SANCTUARIES**

Antitumour drugs frequently fail to reach all sites of tumour cells, and so-called "sanctuaries" may exist that permit the establishment and unimpeded proliferation of a tumour once it has been successfully eradicated from the remainder of the body. Sanctuaries may develop because of the metastatic spread of tumours to distant sites, and the problem may be accentuated by a lack of knowledge regarding the mechanism of drug access to such secondary neoplasms and their susceptibility to various drugs.

The central nervous system is impermeable to many drugs and often represents such a protected site. Attempts to reach sequestered cells have included intrathecal administration of drugs or use of more highly lipid-soluble drugs capable of rapidly penetrating the blood-brain barrier. The success of peripheral chemotherapy in the leukaemias is due in part to the ease with which high levels of drug can be achieved in tumour cells; on the other hand, leukaemic cells that have penetrated the central nervous system are no longer affected by most drugs, and disease progresses.

A more common problem, however, is the diminished blood supply in many solid tumours that blocks delivery of antitumour drugs to the tumour core, which, although necrotic, may still contain active cells sensitive to antitumour drugs. It should be remembered



that high doses of radiation (as used in the primary treatment of many gynaecologic cancers) produce vascular damage leading to the formation of ischaemic sanctuaries for cells that might otherwise be sensitive to drug treatment.

### Secondary Malignancies

Antineoplastic agents have the potential to induce secondary malignancies. The alkylating agent melphalan is associated with a cumulative 7-year risk of acute nonlymphocytic leukaemia in 9.6 per cent of patients treated for more than 1 year. The development of acute leukaemia is also associated with combined chemotherapy and radiation. Secondary malignancies usually occur between 4 and 7 years after successful therapy.

### ROUTE OF ADMINISTRATION

Chemotherapeutic drugs can be administered orally, intravenously, intramuscularly, or intra-arterially. The particular localisation of gynaecologic tumours has led to the development of intraperitoneal and intrapleural chemotherapy regimens. Pleural and intraperitoneal

clearance of the agent is usually slower than plasma clearance, leading to prolonged and increased concentrations of the drug. Clinical trials in ovarian cancer have used intraperitoneal cisplatin and paclitaxel with significantly improved survival compared to systemic chemotherapy. The treatment is usually well tolerated. Frequent local side effects include peritoneal irritation with abdominal discomfort and complications related to the intraperitoneal administration, such as infection at the catheter site. Systemic side effects were unexpectedly reported to be worse with intraperitoneal treatment.

In summary, successful drug therapy requires the administration of an effective agent using the best possible dose and schedule. The tumour must have a high growth fraction and must be accessible to drugs so that they can exert their antitumour effects (i.e., cells must not be in tumour sanctuaries). The tumour volume must be small or the fractional cell kill large to avoid the emergence of a resistant cell clone or the development of tolerance in previously sensitive cell clones. Normal tissue must recover from drug injury faster than tumour can regenerate to pretreatment levels.

# CHAPTER 35

## Radiotherapy in Gynaecological Malignancies

The Biological Basis of Radiotherapy Treatment	568	Aggressive Histological Variants	570
Radiation Dosage	569	Radiotherapy in Carcinoma Cervix	571
The Therapeutic Ratio	569	Brachytherapy in Carcinoma Cervix	571
Radiotherapy Machines	569	External RT Techniques	571
Brachytherapy	569	Chemoradiation in Locally Advanced Carcinoma Cervix	571
Radiotherapy in Endometrial Cancer	570		

### Radiotherapy

Radiotherapy is the art of using ionising radiation to destroy malignant tumours whilst minimising damage to normal tissues.

#### THE BIOLOGICAL BASIS OF RADIOTHERAPY TREATMENT

In medical practice the reasons why tumours are destroyed and normal tissues recover following radiotherapy are complex and poorly understood. The mechanism of action of radiation is that radiation kills cells by the production of secondary charged particles and free radicals, which interact with the nucleic acids. Number of double-stranded DNA breaks produced in the nucleus is related to cellular lethality. The sensitivity of tissues to radiotherapy seems to depend on their ability to repair radiation damage, repopulate and re-oxygenate. The capacity to repair double- and single-strand DNA breaks varies between normal tissue and different tumours. The ability to repopulate is important, as cells can divide rapidly to replace cells killed by radiation. Normal tissues such as the buccal mucosa in the mouth and bone marrow have a considerable number of cells in the G<sub>0</sub> resting phase of the cell cycle that can be rapidly stimulated to divide to replace dead cells. Unfortunately, well-differentiated and moderately well-differentiated squamous carcinomas of the head and neck region have a marked ability to repopulate, and this may account for radiation failure in the treatment of some of these tumours. As tumours grow, new blood vessels develop to feed the neoplasm. By and large, the new blood vessels are primitive in nature and the blood supply is inadequate to supply the growing tumour. Necrotic areas develop within such tumours. These areas contain hypoxic cells, which are a source of radioresistance. However, following a course of radiation treatment, cells that were initially hypoxic can re-oxygenate and become more radiosensitive.

### RADIATION DOSAGE

It is necessary to understand the radiation absorption and the dosage. The interaction of radiation with tissues is measured as the absorbed dose, which is the quantity of energy absorbed per unit mass. In the SI system of units, this is measured as joules per kilogram. One J/kg is 1 gray (Gy). 1Gy equals 100 rad, the unit used previously. The side effects caused by radiation limits the radiation dose given in an attempt to cure a tumour is the risk of normal tissue damage. This damage is seen initially as acute radiation effects in rapidly proliferating cells such as skin epithelium, mucosal lining of the upper digestive tract or the surface lining of the small bowel. This may manifest itself as moist desquamation of the skin, mucositis inside the mouth or diarrhoea caused by damage to jejunal crypt cells. This damage normally heals. What is more worrying is the risk of late damage which appears 9 months to 5 years after treatment, owing to the effects on slowly proliferating tissue, particularly vascular endothelium. This leads to necrosis, fistulae or stricture. The serious complication rate for patients treated for carcinoma of the cervix by radical radiotherapy is about 5 per cent. This is one of the highest complication rates in clinical radiotherapy.

### THE THERAPEUTIC RATIO

The therapeutic ratio has been defined as the relationship between the desired and undesired effects of therapy. One method to reduce the risk of normal tissue injury and increase the therapeutic ratio is to fractionate treatment. The total radiation dose is divided into 20-30 separate treatments and given daily over 4 to 6 weeks. Another method of increasing the therapeutic ratio is the use of continuous low-dose-rate radiation. Such treatments are usually referred to as brachytherapy short-distance treatment.

### RADIOTHERAPY MACHINES

The important and most useful of the modern radiotherapy department is the linear accelerator, which is used to produce X-rays of energies of 4-20 million electron volts (MeV). Such X-rays have major clinical advantages over low-energy X-rays generated by older kilovoltage machines. Megavoltage X-rays are relatively 'skin sparing'. It is fairly easy to treat deep-seated tumours with a homogeneous radiation beam and the

radiation dose to bone is no higher than surrounding tissues. Older kilovoltage apparatus generates X-rays of 100 000 to 300 000 electron volts (KeV). These machines look similar to diagnostic X-ray units and produce X-rays which are only two or three times more energetic than those used to take diagnostic radiographs. The maximum energy of kilovoltage X-rays is deposited on the skin surface and moist desquamation of the skin is often dose limiting. The dose received by bone is higher than soft tissues. It is difficult to treat deep-seated tumours as these X-rays are rapidly attenuated; therefore, at present, kilovoltage machines are relegated to low-dose palliative treatments or the treatment of superficial tumours. An alternative to a linear accelerator is a highly radioactive cobalt 60 source, which produces a gamma ray with similar physical characteristics to a 3 MeV X-ray beam. Cobalt machines are much simpler than linear accelerators but the source requires replacement about every 3 years. In the past, cobalt was viewed as a cheaper, simpler, more reliable alternative to a linear accelerator. However, linear accelerators are gradually becoming more reliable and cheaper. On the other hand, the cost of replacing cobalt sources is rising; therefore, increasingly, cobalt machines are viewed as obsolescent or obsolete.

### BRACHYTHERAPY

Brachytherapy is an essential part of the radiotherapy treatment of cervical cancer and has a role to play in the treatment of endometrial cancer. Previously, tubes containing either radium or caesium were placed within the uterus or vagina. Results from such treatment could be very good. Unfortunately, operating theatre staff and nurses looking after the patients received a significant radiation dose. In order to reduce staff radiation exposure, various afterloading devices have been introduced. The most popular device is the Selectron. Stainless steel pellets containing caesium in glass move backwards and forwards pneumatically from a computer-controlled, lead-lined safe into interuterine and vaginal applicators. This allows the nurse to leave the room after treatment. If he or she needs to return, the radioactive sources can be rapidly returned to the safe at a touch of a button. Increasingly, use of the high-dose-rate brachytherapy (HDR) is being done, usually using high-intensity iridium sources. Such treatment is completed in a matter of a few minutes. There are

retrospective studies (but no randomised controlled trials) that suggest HDR is more effective than traditional, manually inserted, low-dose-rate sources or the intermediate dose rate Selectron.

## RADIOTHERAPY IN ENDOMETRIAL CANCER

Radiation therapy has traditionally been widely applied in the management of patients with endometrial cancer. While primarily delivered as adjuvant therapy following initial surgery, radiotherapy has also been used pre-operatively, or as the sole treatment modality in medically inoperable patients. At present, the role of radiotherapy in endometrial cancer is being understood better with changes in primary surgical staging procedures and improved understanding of prognostic factors and patterns of failure. When radiotherapy is recommended in addition to surgery in contemporary management of endometrial cancer it is most often given as post-operative adjuvant therapy. In the past, pre-operative radiation was more frequently used but this approach has lost favour due to delay in definitive treatment, potential loss of pathological information and inability to tailor adjuvant therapy appropriately to specific surgicopathological findings.

### Endometrial Cancer Confined to Uterus Body

Most patients undergoing primary surgery for endometrial cancer will have malignancy confined to the uterus and, in particular, to the uterine fundus. Various intrauterine pathological features, most notably tumour grade and depth of myometrial invasion, are prognostic for outcome. Based on somewhat arbitrary combinations and thresholds of these pathological risk factors, a broad range of adjuvant treatment options have historically been implemented, including no additional therapy, vaginal brachytherapy alone, or external beam pelvic radiation with or without supplemental vaginal brachytherapy. Surgical aggressiveness and extent, particularly with respect to lymph node assessment, have important prognostic and therapeutic implications. The presence of extrauterine tumour spread is partly reflective of the surgical diligence with which it is sought. With greater emphasis on operative staging, clinical stage I/II patients who, in the past, were deemed at possible risk for nodal metastases are now surgically upstaged if extrauterine disease is

documented and are excluded from contemporary analyses of uterus-confined tumours. The adverse prognosis of patients with nodal and extrauterine metastases is well known.

### Clinicopathologic Prognostic Variables

Historically, the most frequently assessed and readily identifiable intrauterine pathological variables were tumour grade and depth of myometrial invasion. Other features that have prognostic implications include cell type (in particular, papillary and clear-cell histologies), lymphovascular space invasion, tumour extension to the lower uterine segment or cervix and tumour bulk.

Based on prospective evaluation of surgicopathological patterns of spread in endometrial cancer by the gynecologic oncology group (GOG) and others, it is now recognised that much of the adverse prognosis associated with intrauterine risk factors is mediated through nodal involvement. For example, the incidence of pelvic nodal metastases is <5 per cent for grade 1 and 2 tumours with no or limited myometrial invasion. In patients with outer third infiltration, nodal disease increases to 19 per cent in grade 2 and 34 per cent in grade 3 tumours.

In a survey of practice patterns among members of the society of gynaecologic oncologists (SGO) reported by Gretz and colleagues in 1996, it was noted that tumour grade and depth of myometrial invasion substantially influenced the decision to perform lymphadenectomy, and the extent of nodal dissection, in stage I tumours.

### AGGRESSIVE HISTOLOGICAL VARIANTS

Papillary serous and clear-cell cancers are unusual and fairly recently recognised variants of endometrial cancer that are typically characterised by their aggressive behaviour, propensity for extrauterine involvement and high relapse rates, possibly independent of other pathological risk factors. A significant number of patients with clinical uterus-confined tumours are found to have extrauterine disease on surgicopathological evaluation, even if the intrauterine component is minimally invasive or non-invasive. A high risk of upper abdominal failure mimicking that of ovarian malignancy, particularly for papillary serous cancer, has prompted some investigators to recommend routine whole abdominopelvic radiation as adjuvant therapy. The decision to recommend adjuvant radiation for patients with endometrial cancer is ultimately dependent on assessment of patient

risk and prognosis. Optimal management requires careful consideration of multiple clinical and pathological variables and requires close collaboration and communication between the gynaecological surgeon, the radiation oncologist and the pathologist.

Contributing to the controversy over the role of adjuvant radiation therapy is the variability with which different investigators characterise overall patient prognosis. While individual surgicopathological features help in assessing prognosis, it is ultimately the overall risk profile in a given patient that effects outcome and treatment recommendations.

It is clear that there exists a large proportion of endometrial cancer patients who enjoy very favourable prognosis and for whom no adjuvant therapy is warranted.

### RADIOTHERAPY IN CARCINOMA CERVIX

Women with stage I disease involving the upper posterior vagina may be treated by radical vaginectomy and pelvic lymphadenectomy. If the uterus is *in situ*, it is removed as a radical hysterectomy specimen. When margins are clear and lymph nodes are negative, no additional therapy is necessary.

The survival of patients with early-stage cervical cancer after radical hysterectomy and pelvic lymphadenectomy depends on several factors like status of the lymph nodes, size of the tumour, involvement of parametrial tissue, depth of invasion, presence or absence of lymph-vascular space invasion.

The most dependent variable associated with survival is the status of the lymph nodes. Patients with negative nodes have an 85 to 90 per cent 5-year survival rate, whereas the survival rate for those with positive nodes ranges from 20 to 74 per cent, depending on the number of nodes involved and the location and size of the metastases.

*Postoperative Radiation:* In an effort to improve survival rates, postoperative radiotherapy has been recommended for patients with high-risk factors such as metastasis to pelvic lymph nodes, invasion of paracervical tissue, deep cervical invasion, or positive surgical margins.

### BRACHYTHERAPY IN CARCINOMA CERVIX

Initially three systems for intracavitary brachytherapy were developed: the Paris, the Stockholm and the

Manchester systems. The systems differed in the type of applicator used, the strength of the source, and time of administration. Today most systems are derivations of the Manchester technique. Point A is 'Classically' defined as being 2 cms above the mucous membrane of the lateral vaginal fornix and 2 cms lateral to the centre of the uterine canal, which corresponds to the paracervical triangle, in the medial edge of the broad ligament, where the uterine vessels crossed the ureters. Point B defined as 5 cms from the midline at the same level as point A was intended to quantify the dose delivered to the obturator nodes.

In current practice, point A dose is used to approximate the average or minimum dose to the tumour. A later definition 'Revised' point A as being 2 cms above the distal end of the lowest source in the cervical canal and 2 cms lateral to the tandem. This is currently accepted as the standard. In practice the os is radiographically demarcated by the tandem collar, whereas the lateral fornix indicated by the colpostat surface. Various applicators have been designed based on the Manchester system with minor modifications. For example, Williamson-fletcher, Howard, Delclos suit etc.

Ideally the tandem should be in the midline, as equidistant as possible from the lateral pelvic wall, crossing the mid long axis of the ovoids, and the vaginal colpostats should be symmetrically positioned against the cervix in relation to the tandem.

### EXTERNAL RT TECHNIQUES

45 to 50 Gy of EBRT required for microscopic disease in regional lymph nodes. Higher doses upto 50-60 Gy needed for heavy microscopic infestation (e.g. sites of close or positive margins; extracapsular lymph node extension).

EBRT is delivered before ICR in patients with:

1. Bulky cervical lesions in order to improve the geometry of ICR application,
2. Exophytic, easily bleeding tumours,
3. Tumours with necrosis or infection
4. Parametrial involvement.

### CHEMORADIATION IN LOCALLY ADVANCED CARCINOMA CERVIX

The chemoradiation administered concurrently has given better results with the advent of platinum based chemotherapy like cisplatin and carboplatin. It is shown

to act synergistically with radiotherapy. It inhibits the potentially lethal damage or sublethal damage repair of tumour cells and increases the radiosensitivity of hypoxic cells. Trials of chemoradiation using a cisplatin based regimen have demonstrated consistent improvements in survival.

### Radiotherapy

Radical radiotherapy gives equal results as that of radical surgery. The patients are treated with a combination of external beam radiotherapy and intracavitary treatment. The total dose to point A will be around 80-85 Gys. With

combined EBRT and Brachytherapy the usual 5 year survival for stage IB is 86-92 per cent and for stage IIA is approximately 75 per cent. The overall pelvic failure rate in stage IB is 5-8 per cent and in stage IIA 15-20 per cent.

### Combined Treatment with Surgery and Radiotherapy

Postoperative radiotherapy decreases the risk of pelvic recurrence in patients, who have lymph node metastases, deep stromal invasion, incomplete resection, positive margins and parametrial involvement.

# CHAPTER 36

## Immunotherapy in Obstetrics and Gynaecology

Introduction	573	Types of Immunotherapy	575
Definition	573	Monoclonal Antibodies as	
Basis of Immunotherapy	573	Therapeutic Agents	577
Causes of Failure of		Other Areas of Application	
Immunosurveillance	573	of Immunotherapy in	
Tumour Associated Antigens	574	Obstetrics and Gynaecology	578

### INTRODUCTION

For several decades, physicians have realised that the human body has immune mechanisms that protect against disease. Sometimes, the disease process overcomes the protective mechanism and manifests as illness. Though immune response to infections was the first and best understood, there is involvement of immune system in the causation of almost all diseases, including neoplasia. Hence attempts have been made to utilise the immune mechanisms to treat several conditions. The application of principles of immune system has been limited in the field of Obstetrics and Gynaecology and is gaining more and more importance. This chapter attempts to review the current status of immunotherapy in this field.

### DEFINITION

Immunotherapy is defined as the **administration of agents that can modulate, induce, modify and alter the inflammatory and immune responses**. The use of patients' own biological system or natural biological reagents to generate the immune response in an attempt to treat disease forms the basis of this.

### BASIS OF IMMUNOTHERAPY

Sir Mcfarlane Burnet suggested the term immunosurveillance to indicate the host immune response to foreign antigens which will result in their destruction. Overwhelming infections, neoplasia and certain disorders of immune system may result in failure of this protective effect causing disease.

### CAUSES OF FAILURE OF IMMUNOSURVEILLANCE

1. Mechanisms causing **decreased immunogenicity** of the disease causing factors ending in immune ignorance. Tumour cell by themselves may be poor antigen presenting cells and the absence of co-stimulatory molecules like B<sub>7</sub> can lead to T cell anergy or apoptosis.

2. Mechanisms causing **immunosuppression** may result from the pathological stimulus itself like neoplasia where IL-10 and TGF  $\beta$  are secreted which decrease T cell responses. There may also be production of enzymes like indolamine 2, 3 dioxygenase which increases the catabolism of tryptophan and this inhibits T cell proliferation. In some conditions, there may be deficiency of IL-2, IL-15, so cytotoxic T cells die out after a few cell divisions.

Immunotherapy aims to overcome immune escape mechanisms. This is achieved by using certain agents like tumour associated antigens which actively or passively act on the immune system. The results of immunotherapy in neoplasia have been encouraging when tumour burden is less than  $10^8$  malignant cells.

### TUMOUR ASSOCIATED ANTIGENS (TAA)

Each tumour is identified by the host immune system because of unique tumour antigens presented on it and they are called **Tumour Associated Antigens (TAA)**. TAAs can be grouped as self or non self antigens.

- a. **Self antigens** form a group of antigens that have been generated from native molecules and maintain their original amino acid sequences. This group includes repressed or silent antigens like Carcino Embryonic Antigen (CEA), Alpha - Feto Protein (AFP) and overtly expressed antigens like HER 2/NEU.
- b. **Non-self antigens** include products of genetic mutation and oncogenic and other pathogenic viruses or other micro-organisms. Genetic mutation like point mutation or translocation may lead to the development of altered novel peptides like oncogene RAS and tumour suppression gene p53. Oncogenic viruses may be DNA or RNA viruses that integrate their genome into human cells resulting in the expression of foreign proteins that form potential TAAs. E.g.: Human papilloma viruses, Epstein Barr virus, Hepatitis B and Hepatitis C viruses.

### Some Specific Tumour Associated Antigens

#### HER 2/NEU

This is a transmembrane protein of Human Epidermal Growth Factor receptor family. It is amplified in 20-30 per cent ovarian cancers and is also considered to have importance in breast cancer. It has cysteine rich extracellular domain that is highly immunogenic. In

studies with mice, protective immunity against HER 2/NEU expressing tumour challenge is achieved by vaccination with full length HER 2/NEU antigen or subunit and has been found to generate CD8+ specific T cell response.

#### Folate Binding Protein (FBP)

Folate Binding Protein functions as a transmembrane transporter of folate. It is expressed more than 80 times normal in certain ovarian malignancies.

#### MUC-1

MUC-1 is a high molecular weight glycoprotein that is rich in serine and threonine residues that are O-Glycosylated. This is expressed on membranes of many glandular epithelial cancer cells including ovary, breast and gastro-intestinal malignancies. There is increased expression of MUC-1 associated with change in profile of glycosyl transferases. This leads to aberrant glycosylation which makes cancer associated mucin structurally different from normal mucin and hence easily recognised by immune system.

#### Carcino Embryonic Antigen (CEA)

CEA is a 180 kd glycoprotein that is normally expressed on the cell surface of foetal colonic mucosa. It is over-expressed in more than 50 per cent of ovarian mucinous carcinomas and about 15 per cent in other ovarian malignancies.

#### p53

p53 is a tumour suppressor gene mutated in 30-50 per cent of ovarian cancers. Mutated form of p53 causes increased half life and hence increased intracellular expression of the abnormal gene. Hence p53 acts as TAA by its mutated form (nonself) and by overexpression (self). P53 also causes cisplatin resistance. Cisplatin causes DNA breaks which are detected by p53 which in turn directs the cell to undergo apoptosis. Hence the absence of normal p53 favours resistance.

Cytotoxic T lymphocytes derived by vaccinating mice with mutant p53 can kill tumour cells expressing mutant forms. Vaccinating mice with mild type (original) p53 can protect mice from challenge with tumour cells expressing mutant p53.



*Sialyl –Tn*

This is a disaccharide antigen that is expressed in the core region of aberrant glycosylated mucins. This is very common in mucinous tumours and is extremely immunogenic.

**TYPES OF IMMUNOTHERAPY**

1. Active Immunotherapy:
  - a. Specific e.g., Vaccines
  - b. Nonspecific like chemical and biological agents.
2. Passive Immunotherapy
  - a. Specific like antisera and monoclonal antibodies
  - b. Nonspecific agents like LAK and TIL.

**Active Immunotherapy**

Immunising the host with materials designed to elicit an immune reaction capable of preventing disease is called active immunotherapy.

*Specific Vaccines*

Vaccines are used because they present the antigens in a better fashion than the original antigen. These vaccines can be administered directly or pulsed with dendrite cells or along with BCG, GM-CSF, recombinant interleukins or other adjuvants.

*Defined antigen directed Vaccines:* These vaccines are prepared using definite tumour associated antigens which may be single or multiple. eg: HER2/NEU, MUC-1, Sialyl-Tn. Disis et al identified immunodominant epitopes from HER2/NEU protein and then used 15-18 amino acid peptides intradermally with GM-CSF to ovarian cancer patients with minimal disease. Patients were able to generate specific immune response to lyse tumour cells.

*Nondefined antigen directed vaccines:* These vaccines contain a collection of potential antigens derived from the tumour. These include:

- a. *Whole cell vaccine:* Here the entire tumour cell is inactivated and presented.
- b. *Whole cell lysate:* The tumour cells are subjected to lytic methods and extracted antigens are used for vaccinating. Zhao et al showed that cytotoxic T cell generated against dendritic cells pulsed with ovarian cancer cell lysate showed significant killing activity against autologous tumour cells.

*Non-Vaccines Specific*

*Biological Immunostimulants*

- a. *BCG:* This live attenuated strain of *M.bovis* (BCG) causes activation of both humoral and cellular immunity and also activation of macrophages. Activation of macrophages is manifested by increased phagocytosis, microbicidal activity and increased metabolism. Most studies were in treatment of melanoma and leukaemia. Dramatic work with BCG was by Rappet et al with transplantable hepatoma in guinea pig. They showed that injection of BCG into group intradermal nodule was capable of eliminating the nodule and tumour cells in draining lymph nodes. BCG can be given intralesionally, intradermally or by scarification. Results have not been very encouraging in gynaecological malignancies. Disadvantage is BCG infection.
- b. *Methanol Extraction Residue (MER):* This is methanol extraction residue of BCG with same effect as that of BCG but without BCG infection.
- c. *Corynebacterium parvum:* Like BCG, *C. parvum* also been found to induce macrophage activation and can be given subcutaneously, im, iv or intraperitoneally. Intraperitoneal administration of *C. parvum* has been noted by Mantovani et al to be useful for palliative treatment of ascites in women with advanced ovarian carcinoma. In animal studies *C. parvum* has been found to induce regression of local and pulmonary metastasis.

*Chemical Immunostimulants:* These include levamisole, cimetidine and lysosome containing macrophage stimulating substances. Levamisole is believed to cause maturation of thymus derived immature lymphocytic precursors. It has been termed immunomodulator by some in that it seems to reconstitute immunological competence in patients who are immunologically suppressed. Administration of levamisole before or after bacterial adjuvants, like BCG has been found to augment the activity of the latter.

*Cytokines:* Cytokines are soluble proteins that have hormone like action and exhibit their effect on immune system through regulation of other cells. Some important cytokines in use are IL-2, IFN $\alpha$  IL-3,  $\gamma$  IL-12.

*IL-2:* Interleukin 2 causes:

1. Activation and proliferation of T lymphocytes

2. Promotion of B cell activation and maturation
3. Activation of monocytes and NK cells
4. Induces Interferons and other cytokines.

IL-2 has been used in paclitaxel and cisplatin resistant tumours by intra peritoneal route and has been found to increase survival. Side effects are flu-like syndrome, hypotension, gastrointestinal side effects, drowsiness, depression, pancytopenia, altered renal function and hypothyroidism. Long term data have been presented from a trial of intraperitoneal IL-2 in patients with refractory ovarian cancers. Among 34 patients – 7 who had laparotomy confirmed complete response and 2 had partial response.

**IL-12:** IL-12 can induce IFN- $\gamma$  and together with IL-2 becomes potent activator of cytotoxic T lymphocytes and NK cells. It also enhances IFN  $\gamma$  mediated upregulation of adhesion molecules on tumour associated blood vessels (ICAM-1, VCAM-1) providing access to circulating lymphocytes. Phase I-II clinical trails with intraperitoneal and systemic IL-12 are in progress.

**IFN- $\alpha$ :** This has also been tried through intraperitoneal route with minimal residual disease in ovarian malignances either alone or with carboplatin (<5 mm). Response rate had been 30-50 per cent; there was no improved response to combination therapy. In ovarian cancers within 24 hrs of initiating therapy with IFN $\alpha$  there were increased NK effectors, macrophages and tumour specific lymphocytes.

Phase II study of alternating of IFN  $\alpha$  and cisplatin included 54 evaluable patients with small volume (<5 mm) residual disease. Surgically confirmed complete responses were observed in 20 per cent of patients.

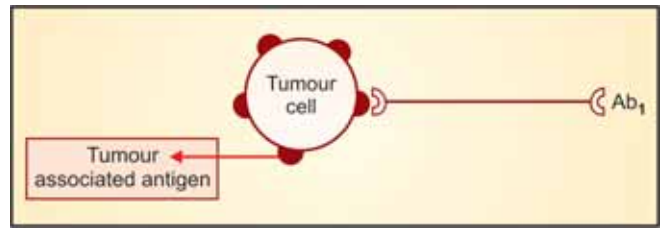
Regional therapy with IFN- $\alpha$  has been evaluated with a topical gel in patients with vulval intraepithelial neoplasia; 67 per cent response rate was achieved with less toxicity than 5-FU.

**Other cytokines:** GM-CSF and IL-3 are known to cause faster bone marrow rescue after chemotherapy.

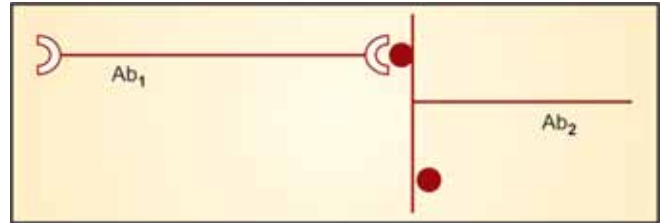
#### Anti-Idiotype Antibodies

Idiotype is the variable region of an antibody that reacts with an antigen. These antibodies are used to stimulate immune response in malignancies and are produced as follows.

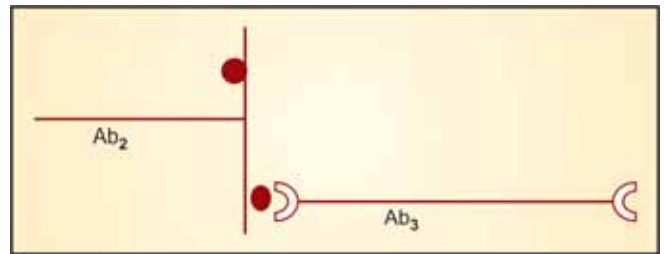
**Step 1:** Tumour associated antigen is introduced into murine model which develops antibody against it.



**Step 2:** Another murine model immunised with Ab<sub>1</sub> to get another antibody response Ab<sub>2</sub>.



**Step 3:** When Ab<sub>2</sub> is introduced into tumour bearing host he develops Ab<sub>3</sub>, a third antibody which closely resembles Ab<sub>1</sub> but reacts much more effectively with TAA than Ab<sub>1</sub>.



#### Passive Immunotherapy/Adoptive Immunotherapy

This involves the transfer of preformed substances or cells that have antitumour activity into the host.

#### Specific

1. Heterologous antisera from immunised humans.
2. Monoclonal Antibodies : (MoAb)

Monoclonal antibodies were developed by Kohler and Milstein by hybridoma technique. The potential for monoclonal antibodies and their conjugates is enormous given the specificity of antigen – antibody reactions. Monoclonal antibodies exert their antitumour action by:

1. Blocking the targeted receptor and preventing its function in transmitting proliferative signals to the nucleus.
2. Activating antibody dependant cellular cytotoxicity internalising the receptor and hence delivering toxic substances to the cell.

### Non-Specific

**LAK (Lymphokine Activated Killer Cell):** These are peripheral lymphocytes cultured in the presence of IL - 2 which then gain the ability to kill tumour cells without MHC restriction. It has been used in combination with IL - 2.

**TIL (Tumour Infiltrating Leucocytes):** These are lymphocytes found infiltrating the tumour site. When these are cultured in vitro in the presence of IL - 2, lymphocytes with better tumour destroying properties are obtained.

## MONOCLONAL ANTIBODIES AS THERAPEUTIC AGENTS

### Application and Uses

#### Anti HER 2/NEU MOAB (Trastuzumab)

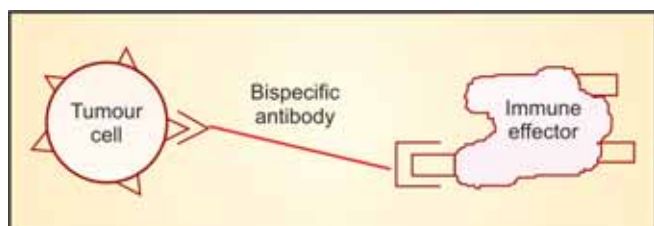
This has been approved by FDA for metastatic breast cancer with taxol. In ovarian cancers, Ceullo et al found that HER 2/NEU down regulates the expression of HER2/NEU receptors in tumour cell lines. But phase II clinical trials show limited value with response rate <10 per cent.

#### Anti CA 125 Antibodies: (B 43.14)

CA125 is over expressed and also secreted into blood stream in more than 97 per cent advanced ovarian cancers. MoAb B 43.14 is murine MoAb against CA125. It binds with circulating CA125 antigen and is recognised as foreign. This leads to development of HAMA (Human Anti Monoclonal Antibody) and anti idiotypic antibody response. This can also be used for CA125 assays.

### Bispecific Monoclonal Antibodies

These antibodies work by binding to antigen at one end and receptor for immune effector cell at the other end this generates immune mediated lytic activity.



Examples include:

- MDX 210 which has receptor for HER 2/NEU and for FC  $\gamma$  receptor 1 of monocyte and macrophages.
- OCTR which has receptors for Folate Receptor and CD3 T lymphocytes.

Phase II trial with 28 patients showed 27 per cent patients had complete or partial intraperitoneal response.

### Radio-Immuno Conjugates

Monoclonal Antibodies are also used along with radionuclide  $\beta$  emitter conjugates. Eg: yttrium 90 Monoclonal antibody-human milk fat globule (HMFG1) which binds specifically to polymorphic epithelial mucin (PEM) an antigen expressed in more than 90 per cent ovarian cancers, conjugated to yttrium 90 isotope has been used in a phase I and II trial in ovarian cancer. These conjugates need not be internalised for their action.

### Immunotoxins

MoAbs can be linked to chemotoxins to allow more specific targeting of these toxins to malignant cells. Examples of some chemotoxins tried are:

- Ricin A
- Pseudomonal Exotoxin
- Salmonella endotoxin
- Methotrexate, Adriamycin.

These immunotoxins require internalisation into the cell for their action, hence they are highly specific. But some tumour cells may shed their antigens into the general circulation and MoAbs may be trapped with free antigens and not reach tumour per se. Further more there may be sharing of antigens between normal and malignant cells.

Pai and colleagues conducted a trial using OVB3-PE which is a MoAb that recognises ovarian cancer and is linked to *Pseudomonal exotoxin*. Phase I trial showed no effect when used intraperitoneally.

### Disadvantages of Monoclonal Antibodies

These include allergic reaction, delayed serum sickness, development of Human Anti-Monoclonal Antibody (HAMA). HAMAs bind to monoclonal antibodies and can affect their activity and distribution. This can be overcome by "humanisation" of the biological agents by substituting Fc murine portion for the human equivalent.

E.g: Herceptin developed against HER 2/NEU.

## OTHER AREAS OF APPLICATION OF IMMUNOTHERAPY IN OBSTETRICS AND GYNAECOLOGY

### Cancer Cervix

Oncogenic viral products of HPV act as Tumour Associated Antigens.

#### *Vaccines in CaCx*

**Prophylactic Vaccines:** Principal goal in prophylactic vaccines to prevent infection by etiological cause. Accordingly they are based on inducing humoral immune response to generate neutralising antibodies. It has been found that HPV virus composed of late proteins L1 and L2 is highly immunogenic and generates humoral response. L1 and L2 when cultured in vitro assembled to form "virus like particles – VLPs". They resemble the native virus and have the same immunogenicity. Vaccination through mucosal route generates IgA response. Vaccines for cancer cervix seem to have evoked great enthusiasm. There is likely to be ethical issues involved in having vaccines for sexually transmitted infections like HPV.

**Therapeutic Vaccines:** Early protein products of HPV E6 and E7 are used in clinical trials in dysplasia and advanced Ca Cx to elicit cell mediated immunity. They have been fused to HSP-65 (heat shock protein) to enhance antigen processing.

### Immunotherapy in Cervical Atypias and Cervical Dysplasias

Topical IFN- $\alpha$  has been used in persistent Atypia and dysplasia at dose  $1 \times 10^6$  IU for 14-21 days with favourable outcome.

### Gestational Trophoblastic Disease

One study with paternal leucocyte immunisation done by Cinander et al showed complete disappearance of choriocarcinoma and pulmonary metastasis.

### Endometriosis

Studies in immunotherapy are underway as endometriosis is believed to be due to abnormal NK cell function. NK cells normally not allow ectopic endo-

metrium to proliferate. Hence the hypothesis that NK cell dysfunction could lead to endometriosis.

### Immunotherapy in Recurrent Pregnancy Loss

Immune regulation which maintains pregnancy is reported to involve both cellular and humoral immunity.

- Suppressor cells found in maternal decidua suppress the maternal immune response to foetus.
- HLA-G antigens expressed on trophoblast cells inhibit NK cells.
- Anti-paternal cytotoxic antibodies have been found with high frequency in sera of normal pregnant women.
- T cell receptor (TCR) anti idiotypic antibodies capable of inhibiting autologous T cell responses are seen.

As immunotherapy for recurrent spontaneous abortion, women are immunised with their partner's lymphocyte in an attempt to enhance the production of immune suppressing antibodies. High success rates of maintaining pregnancy have been achieved.

### Immunotherapy in Anti Phospholipid Antibody Syndrome (APAS)

Immunotherapy in the form of immunoglobulin therapy has usually been reserved for women with overt disease or heparin induced thrombocytopenia or both. Immunoglobulin is administered intravenously in doses of 0.4 mg/kg daily for 5 days for a total of 2 g/kg. This is repeated monthly or given as a single dose of 1g/kg each month.

### Immunotherapy in Septic Shock

Anti endotoxin antibody serum has been studied extensively for gram negative sepsis and septic shock. Studies are underway with monoclonal antibody to Lipid A, E5 murine monoclonal IgM, anti endotoxin antibody for ARDS and recombinant fusion protein of p55-TNF- $\alpha$  to competitively block TNF  $\alpha$ .

Immunotherapy seems to have an exciting future in the management of several conditions in Obstetrics and Gynaecology. As better understanding occurs about the role of immune system in the pathogenesis of diseases, more application for the use of immunotherapy are likely to be discovered.

# Amenorrhoea, Hypomenorrhoea and Oligomenorrhoea

Amenorrhoea	579
Hypomenorrhoea	595
Oligomenorrhoea	596

## AMENORRHOEA

Amenorrhoea means 'without menstruation'. Primary amenorrhoea is the absence of menstruation by 16 years of age in the presence of normal secondary sexual characteristics, or by 14 years of age if secondary sexual characteristics have not developed. Secondary amenorrhoea is the absence of menstruation for three normal cycles or for six months. Any woman who complains of amenorrhoea may be suffering from either of the following.

### False Amenorrhoea

In this condition menstruation is taking place but the patient is unaware of it because the outflow is obstructed at the level of the cervix, vagina or vulva. This is hidden menstruation or *cryptomenorrhoea* and has already been considered in Chapters 13 and 15.

### True Amenorrhoea

This condition is the subject of this chapter. It is one in which the menstrual function is suppressed and the explanation may be physiological or pathological.

## AETIOLOGY

### Physiological Amenorrhoea

#### *Before Puberty*

Amenorrhoea is normal during childhood and is explained mainly by a low output of gonadotrophin releasing factor(s). Menstruation is usually established by the age of 16 years but may not appear until the age of 18 years (and sometimes later) without there being an abnormality (constitutional amenorrhoea).

#### *Adolescence*

Initial menstrual cycles are often anovulatory and therefore irregular. Periods of amenorrhoea lasting 2-12 months during the first 1-2 years after the menarche are

so common that they should be regarded as normal. They occur in 20 per cent of girls without subsequent ill effect on their fertility.

### Pregnancy

*Pregnancy is the commonest cause of secondary amenorrhoea* and suppression of menstruation is the leading symptom of early pregnancy. The amenorrhoea is caused by a continuous production of large quantities of oestrogen and progesterone by the chorion.

### Lactation

Menstruation is suppressed for varying periods after abortion and labour, but especially by lactation when the hypothalamic-pituitary system concentrates on the production of prolactin rather than gonadotrophins.

### Menopause

The menopause comes about because the ovaries cease to react to the gonadotrophic stimulus when all their graafian follicles have disappeared. It occurs usually between the ages of 45 and 55 years and should be diagnosed with great reluctance before the age of 40 years. Periods of physiological amenorrhoea lasting 3-6 months often precede the menopause itself.

## Pathological Amenorrhoea

Three types:

1. Amenorrhoea without secondary sexual characteristics
2. Amenorrhoea with secondary sexual characteristics and anatomic abnormalities
3. Amenorrhoea with secondary sexual characteristics and nonanatomic causes

In order to detect the cause of amenorrhoea, it is useful to determine whether secondary sexual characteristics are present. The absence of secondary sexual characteristics indicates that a woman has never been exposed to oestrogen stimulation. If the secondary sexual characteristics are present i.e: When the findings of the physical examination are normal, anatomic abnormalities may still be considered. If the secondary sexual characteristics are present with non anatomic causes could be connected to ovarian failure, pituitary and hypothalamic lesions, and abnormal hypothalamic GnRH secretion.

Amenorrhoea is a symptom, not a disease, and has a variety of causes. A complete list is impossible here but groups of causes can usefully be recognised. The division of amenorrhoea into *primary* and *secondary* types has some clinical value in that it may be a rough guide to aetiology and prognosis. Secondary amenorrhoea, for example, is more likely than primary to be the result of pregnancy or acquired disease; it is less likely to be caused by a gross error in the development of either the uterus or ovaries, and is therefore more amenable to treatment. Nevertheless, the possible causes of both types are essentially the same.

Menstruation is dependent on the proper functioning of a chain made up of: hypothalamus → pituitary → ovary → uterus; amenorrhoea presupposes a weakening or break in one or more of these links. Although set out separately below, there is a good deal of overlap and interplay between the different groups of causes, and with other factors which influence the links in the chain.

### Hypothalamic Amenorrhoea

Disturbances of the hypothalamus cause amenorrhoea by interfering with the production of GnRH and, since other releasing factors may be involved, the amenorrhoea can be accompanied by other symptoms such as galactorrhoea and errors in physical growth. The hypothalamus has centres controlling appetite and metabolism so overeating, undereating, obesity or wasting, and faults in fluid balance can be associated with suppression of menstruation. The consequence is that amenorrhoea is a feature of syndromes such as *pituitary infantilism*, the Chiari-Frommel and Forbes syndromes (*see* Chapter 11) and dystrophia adiposogenitalis (*Frohlich's syndrome*). In the last, genital hypoplasia is combined with obesity and sleepiness.

Upsets in hypothalamic function can be caused by the following:

#### *Disease or Injury in the Region of the Midbrain*

These include encephalitis, meningitis, tumours and fractures of the base of the skull.

#### *Cerebral Cortex Influences*

- *Psychoses*: Amenorrhoea is a common feature of depressive mental disorders, and is also seen following electroconvulsive therapy.

- *Emotional upsets and stresses:* Examples of these include nervous shocks, the death of a friend or relative, change of work or abode, separation from close acquaintances, travel abroad, a love affair and marriage.

The effect of nervous tensions is seen not only in causing amenorrhoea but also in curing it. So it often happens that a woman with this complaint begins to menstruate spontaneously on the day she has planned to take medical advice.

- *Pseudocyesis:* In this rare condition a woman imagines that she is pregnant and accordingly suppresses her menstrual function and develops other symptoms and signs of pregnancy such as nausea and vomiting, breast changes, increase in weight and swelling of the abdomen. She may even allege that she can feel foetal movements and, ultimately, that she is in labour. The enlargement of the abdomen is *not* the result of gaseous distension but of an unusual use of the muscles of the trunk and an assumed lordosis; it therefore disappears if the woman is given a general anaesthetic. This, however, should not be necessary to demonstrate that the tumour is a phantom; resonance on percussion is conclusive evidence. Ultrasonic views of the abdomen are of help in confirming the diagnosis and convincing the patient.

Pseudocyesis results from fear of, or desire for, pregnancy. It is mostly seen in women suffering from infertility, and in those approaching the menopause, who either see their last chance of conception disappearing or suddenly realise what an embarrassment another pregnancy at that age would be.

The syndrome is not always complete and amenorrhoea can occur without other clinical manifestations. Moreover, in most cases menstruation is not entirely suppressed and the patient will, under pressure, admit to scanty cyclical losses.

- Anorexia nervosa.
- Polycystic ovary syndrome.

### Drugs

These include the phenothiazine derivatives, reserpine and ganglion-blocking agents, all of which affect the hypothalamus by reducing the prolactin-inhibiting factor (PIF) levels, thereby resulting in an elevated prolactin level. Amenorrhoea is also seen with drug addiction of various types and with certain chemotherapeutic agents, especially alkylating agents.

The most important of the drugs which cause amenorrhoea, sometimes with galactorrhoea, are the *oestrogen-progestogen oral contraceptives*, which can produce what is called the *oversuppressive syndrome or post-pill amenorrhoea*. The occurrence is not related to the length of time during which the woman has taken the pill; it seems that some women have a hypothalamic-pituitary system which is unusually sensitive to the inhibition which these hormones provide. Although many women experience a brief delay in the onset of menstruation after they stop the pill, only a small proportion develop secondary amenorrhoea of 6 months' duration. Approximately 80 per cent of women resume a normal menstrual pattern within 3 months of stopping the pill and 95-98 per cent are ovulating regularly within one year. The degree of risk involved in developing post-pill amenorrhoea of at least 6 months' duration is estimated at less than 1 per cent. In some women it is recognised that the amenorrhoea which follows stopping taking the pill is merely a stage in the progression of a previous oligomenorrhoea.

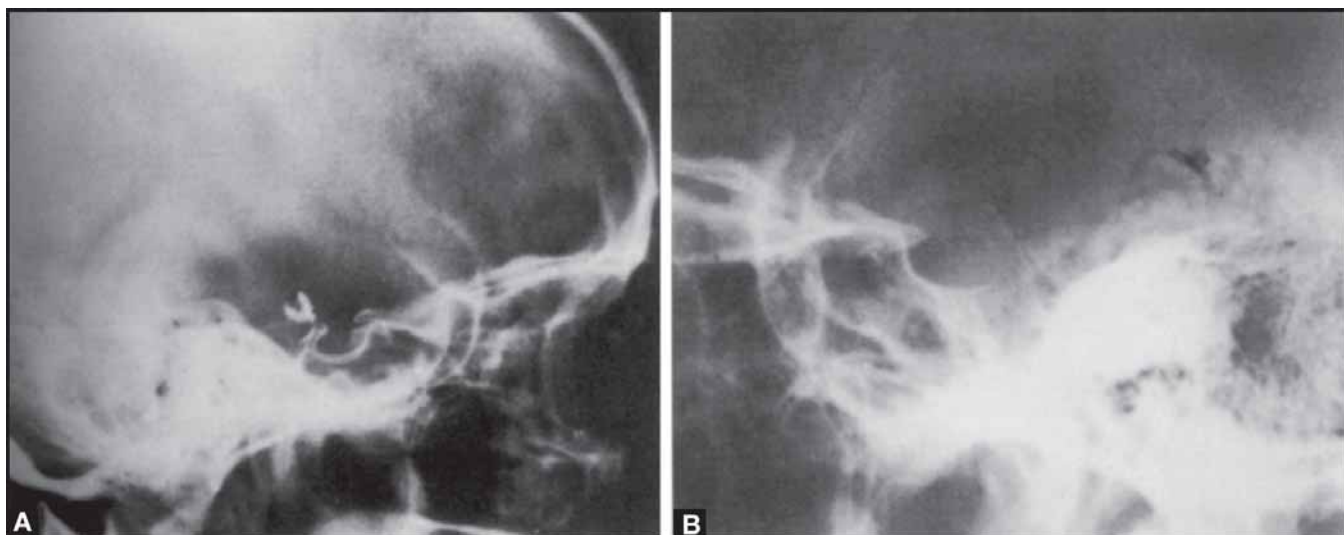
Although the amenorrhoea associated with the taking of oral contraceptives is assumed to be due to suppression of hypothalamic-pituitary function, an organic change must be excluded for certain (Figs 37.1A and B). Certainly, care is necessary in excluding other causes. It has been shown that whenever a diagnosis of post-pill amenorrhoea (of 6 months or longer) is made, there is a 10 per cent chance of missing premature ovarian failure, a 20 per cent chance of missing hyperprolactinaemia and a 30 per cent chance of missing weight-related amenorrhoea.

While amenorrhoea persists, the levels of follicle-stimulating hormone (FSH), luteinising hormone (LH) and oestrogens in body fluids are low and the ovaries are inactive.

Spontaneous cure is the outcome in 25 per cent of cases, and this can happen even after one year; it is recorded as late as after six years. Otherwise, ovulation and menstruation can be induced artificially and pregnancy can result. Thereafter, menstruation sometimes returns but not always.

### Pituitary Amenorrhoea

True pituitary amenorrhoea is not common and when it occurs it can be accompanied by other evidence of disturbed pituitary function. An *isolated pituitary gonadotrophin deficiency syndrome* is described but its one



**Figs 37.1A and B:** Diseases of the midbrain and pituitary causing amenorrhoea without other symptoms, (A) A craniopharyngioma causing primary amenorrhoea in a woman aged 25 years. The lesion is indicated by the area of calcification just above and behind the posterior clinoid process, the patient facing to the right, (B) A probable pituitary tumour indicated by enlargement of the pituitary fossa and destruction of the posterior clinoid processes, the patient facing to the left. In this case a parous woman complained of secondary amenorrhoea following the taking of an oestrogen-progestogen contraceptive pill for 3 years. Until this radiograph was taken it was assumed that the amenorrhoea was the result of continued inhibition of the hypothalamus following the therapy

symptom of amenorrhoea can be cured by administering GnRH, so it now appears that the trouble is in the hypothalamus.

Upsets in the function of the anterior pituitary can be caused by the following:

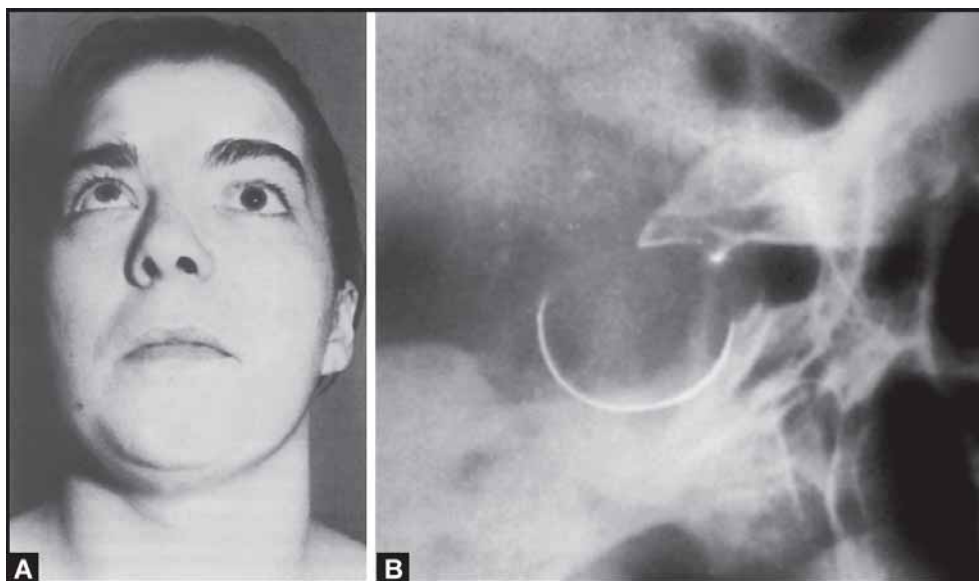
*Tumours in or near the pituitary gland:* It is now recognised that pituitary adenomas are more common than originally thought because of the sophisticated methods available to diagnose them.

The clinical effects depend on tumour size, rate of growth and hormonal secretion, but endocrinological symptoms such as amenorrhoea appear long before the neurological symptoms (Figs 37.1A to 37.2B). In about three-quarters of these adenomas there is an excess production of prolactin, but growth hormone may be produced in excess leading to acromegaly. In general, tumours outside the pituitary fossa will produce neurological symptoms before endocrine abnormalities. Progressive lesions (tumours, granulomas or infections) will impair both pituitary and hypothalamic function in time. One condition which has to be excluded when looking for a pituitary microadenoma is an empty sella turcica in which the amenorrhoea is due to hypopituitary function.

*Disease of the anterior pituitary:* Any destructive disease can reduce or eliminate the gonadotrophic and other functions of the gland to produce a clinical picture similar to that of *Sheehan's syndrome*. This syndrome, however, is characteristically caused by ischaemic necrosis of most of the anterior pituitary which results from spasm in its arterioles occurring at the time of severe haemorrhage or shock (usually postpartum) complicating childbirth.

This peculiar reaction to shock is hardly ever seen except in the parturient woman and in explanation it is suggested that normally during labour the blood supply to the pituitary gland is modified to the advantage of the posterior lobe and disadvantage of the anterior lobe. When spasm occurs, therefore, the posterior lobe is protected and the anterior lobe is vulnerable. The risk of this ischaemic injury occurring in women suffering postpartum haemorrhage and shock depends on the speed and efficiency with which blood loss is controlled and replaced. Nevertheless, even where maternity services are highly developed, it is reckoned that 4 per cent of women who lose more than 800 ml of blood in the third or fourth stages of labour suffer some degree of damage to the anterior pituitary. The figures rise to 8 per cent for moderate, and 50 per cent for severe postpartum haemorrhage and shock.





**Figs 37.2A and B:** A pituitary tumour causing amenorrhoea for 9 months in a primipara aged 24 years. She had been given oestrogens which produced cyclical uterine bleeding and had also been treated by an ophthalmologist for 'defective vision', (A) Examination revealed fixation of the left eye and swelling of the lower lid. (B) Radiological examination of the skull showed a grossly enlarged sella turcica with so much erosion of the bones that the outline of the fossa is shown here in white ink. The patient is facing to the right

In the fully developed syndrome (Simmond's) which is only seen when 95 per cent of the anterior pituitary is destroyed, all functions — lactogenic, gonadotrophic, thyrotrophic, corticotrophic and somatotrophic — are impaired. Lactation does not occur after the causal delivery and later there develop amenorrhoea, loss of libido and evidence of hypothyroidism, although the blood cholesterol level usually remains normal. The woman becomes sensitive to cold and is apathetic; so in cold climates she sits by the fire and develops severe *erythema ab igne*. Insulin tolerance is reduced and spontaneous hypoglycaemia is common.

Acute crises can develop and coma may be caused by hypoglycaemia, hypothermia and hypothyroidism; death under anaesthesia used to be common.

Signs of adrenal cortical failure include absence of axillary sweating, loss of axillary and pubic hair, and decrease in skin pigmentation. The last mainly accounts for the striking pallor of these women but they also have a moderate degree of anaemia which is caused by lack of the pituitary erythropoietic factor. There is no significant decrease in weight.

The plasma levels of FSH, LH, TSH, ACTH, oestrogens, and urinary 17-keto- and ketogenic steroids

are considerably reduced, and may be negligible. All the genital organs show extreme atrophy; the uterus becomes smaller than it does in the normal post-menopausal state.

Although dormant, the ovaries retain their ova until the natural age of the menopause, when they disappear. Meanwhile, however, they respond readily to gonadotrophin therapy to result in ovulation, menstruation and conception. If the woman does have another pregnancy as a result of such treatment, it seems sometimes to lead to an improvement of pituitary function afterwards.

Less extensive destruction of the anterior pituitary can lead to an incomplete, or delayed, onset of Sheehan's syndrome. In such a case, lactation may not fail, and menstruation may continue regularly or intermittently for several years after the causal childbirth. Weakness and apathy are often the only complaints but the clinical features and hormone levels are directly related to the amount of remaining functional pituitary tissue.

#### *Ovarian Amenorrhoea*

In this group, the hormonal disturbance causing amenorrhoea appears to arise primarily in the ovary.

*Underproduction of oestrogen and progesterone (Hypergonadotrophic amenorrhoea):* An obvious example of this mechanism is the amenorrhoea which follows surgical removal of both ovaries or exposure of the follicular apparatus to radiation or sometimes after chemotherapy especially with alkylating agents. The natural menopause itself is another illustration of primary ovarian failure and there are cases of ovaries which are resistant to gonadotrophic stimuli (resistant ovary syndrome). In these patients, follicles are present deep within the ovary and can be demonstrated either by ultrasound or by a full-thickness biopsy at laparotomy. Premature ovarian failure is associated with other autoimmune diseases.

The ovary, although present, may never develop a capacity to respond to the gonadotrophin stimulus or, having very few ova, may do so for only a few years or intermittently. This usually betokens an abnormal sex chromosome pattern such as 47,XXX, 46,XX/45,XO or deletion of fragments and isochromosomes. More commonly, however, unreactive gonads are 'streak' or even testes in an apparent woman (*see* Chapter 14). Thirty per cent of all women presenting with *primary* amenorrhoea have demonstrable chromosome anomalies; if those who have another obvious cause for their symptom are excluded, the figure is 40-45 per cent. Rarely, patients with galactosaemia may have fewer oogonia because of the effect of galactose on germ cell

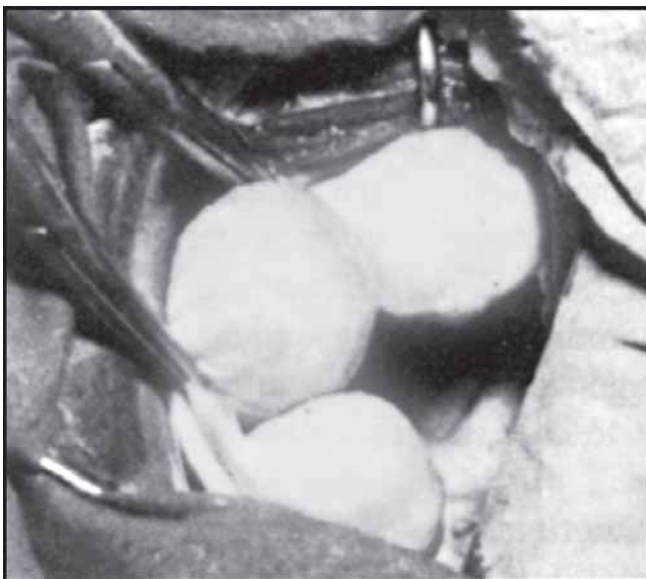
migration; they may also have defective carbohydrate moieties which render the FSH and LH inactive.

*Continuous production of oestrogen and progesterone:* Menstruation depends on the cyclical withdrawal of steroid hormones so when these are produced continuously rather than intermittently, amenorrhoea can result. There may, therefore, be an amenorrhoeic phase in cases of follicular cysts, persisting luteal cysts, and granulosa and theca cell tumours. Amenorrhoea in the woman who has previously had a trophoblastic tumour means persisting or renewed trophoblastic activity with luteinisation of the ovaries.

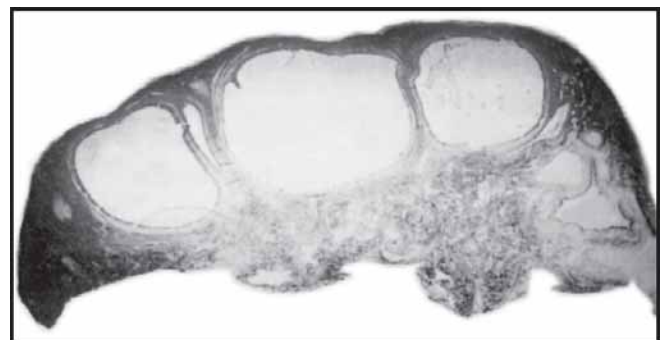
*Overproduction of androgens:* Androgens inhibit endometrial and follicular activity, so masculinising tumours of the ovary cause amenorrhoea, usually of the secondary variety. This is accompanied by other signs of virilism.

*Polycystic ovary syndrome:* The oestrogen, progesterone and androgen normally produced by the ovary are chemically interchangeable, androgens being intermediate products in the biosynthesis of oestradiol. Ovarian metabolic errors may therefore explain certain anomalies in hormone production which are associated with amenorrhoea.

The best example is the polycystic ovary syndrome (PCOS). In this, the patient typically complains of amenorrhoea or oligomenorrhoea, is infertile and has slightly enlarged and polycystic ovaries which have a smooth pearly coloured and thickened capsule. There is a failure to ovulate, the follicles becoming cystic and showing, on section, hyperplasia of the theca interna (Figs 37.3 and 37.4). The syndrome is seen in the second and third decades of life and, in about 50 per cent of cases, includes obesity, hirsutism and acne. Hyper-



**Fig. 37.3:** The large, pale, thin-coated ovaries, typical of the polycystic ovary syndrome lying on either side of the fundus of the uterus at the time of laparotomy

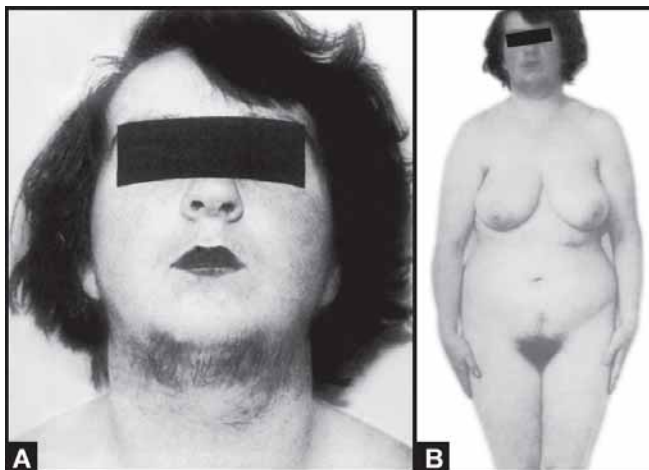


**Fig. 37.4:** A slice of the ovarian cortex of a polycystic ovary (Presented by Dr K. V. Bailey and reproduced by permission of the Editor, *J Obstet Gynaecol Br Emp*)

insulaemia is associated. The lipoprotein pattern is similar to that in males. These patients are at increased risk of endometrial and breast cancer, cardiovascular disease and diabetes mellitus. Advances in ultrasound have improved the diagnosis of PCOS (Figs 37.5A and B) which is found to be prevalent in up to 20 per cent of normal women but in up to 60 per cent of women with hirsutism, acne and menstrual disturbances. However ultrasonography is not essential for the diagnosis of PCOS.

It is supposed that the hyperthecosis is related to an overproduction of androgens which reduces granulosa cell proliferation and maturation, as well as stimulating fibrosis of the surrounding stroma and capsule. In fact, there are no specific histological features which characterise the ovary in PCOS. Follicular as well as theca lutein cysts may be present; moreover, ripening follicles and occasionally an active corpus luteum can be found (Figs 37.6A to C). This means that ovulation may occur intermittently, and this despite the thick capsule!

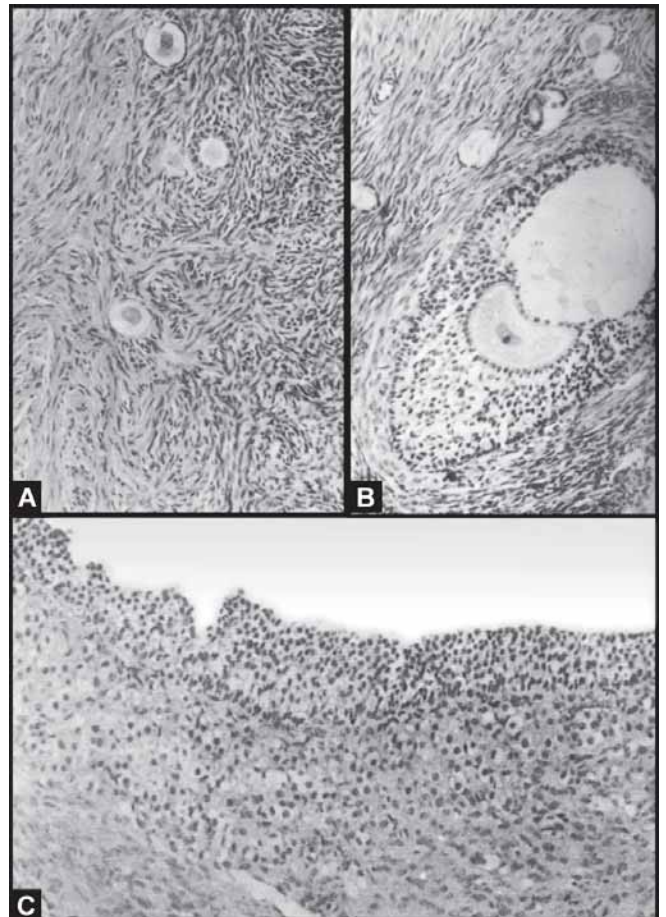
Irrespective of the microscopic appearances, however, it is clearly established that there is no defect in the hypothalamic-pituitary-ovarian axis. Normal function is, however, masked by inhibition of ovarian follicular development and inappropriate feedback to the pituitary. The high oestrogen production is largely due to conversion of androgens to oestrogen in the ovary and peripherally. This causes an increase in LH and a decrease in FSH, the LH level being 3 to 4 times the FSH



**Fig. 37.5:** The polycystic ovary syndrome. This girl, aged 18 years, complained of secondary amenorrhoea and facial hirsutism. She was also overweight, with good breast development. Menstruation returned after wedge resection of polycystic ovaries

level on day 2 of the cycle. A vicious circle is established, for the increase in LH induces thecal hyperplasia and increased androgen synthesis in the ovary.

High levels of androgen result in an increase in the peripheral production of oestrogen and a reduction in the sex hormone-binding globulin. This leads to an increased level of free androgens to produce hirsutism and to be converted to oestrogens. There is also anovulation as a result of the effect of the androgens on follicular maturation. The degree of hyperandrogenism is proportional to the degree of hyperinsulinaemia. Another consequence of the raised oestrogen levels is



**Figs 37.6A to C:** The variable microscopic appearances of the ovary in the polycystic ovary syndrome. The three sections illustrated were obtained from the same ovary of a woman whose oligomenorrhoea and infertility appeared to be cured by wedge resection of polycystic ovaries, (A) Normal primordial and primary follicles in masses of theca tissue, (B) A ripening graafian follicle, (C) The wall of one of the cysts lined by granulosa cells with theca outside; the latter shows evidence of luteinisation. (By permission of the Editor, *Am J Obstet Gynecol*)

the target organ effect on adipose tissue formation and endometrial hyperplasia.

As might be expected from the above, the vagina and the uterus do not show signs of atrophy, despite the amenorrhoea. Vaginal cytology and endometrial histology can show evidence of high or low oestrogen production. The endometrium is sometimes unstimulated, occasionally secretory and sometimes hyperplastic. In the latter circumstance, atypical hyperplasia can be found; so the woman with PCOS may be prone to develop carcinoma of the body of the uterus.

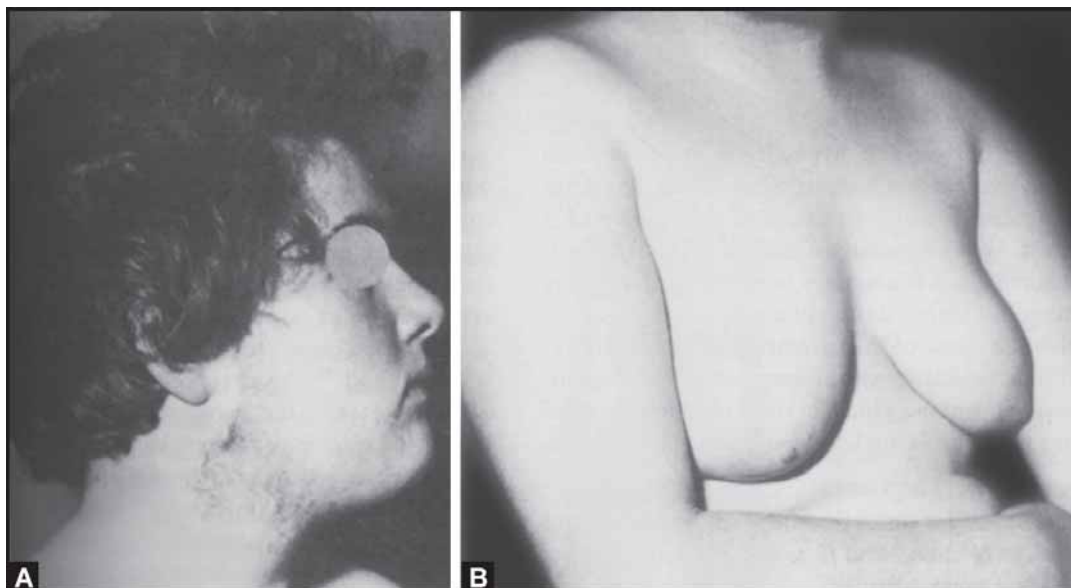
There are many conflicting features about this syndrome which is predominantly defeminising. One of these is that the breasts are nearly always well developed and, quite often, they show areolar and other changes which mimic those seen in pregnancy (Figs 37.5 and 37.7). These, associated as they generally are with episodes of amenorrhoea, often give rise to a clinical suspicion that the woman has conceived.

Although we have a greater knowledge and understanding of the hormonal effects, the cause of the PCOS remains unknown. It is accepted as a clinical entity but the starting point in the circle of endocrine disturbances is debatable. It is suggested that there may be a disturbance of adrenocortical function in the prepubertal

and postpubertal phase of life initially, followed by a shift to ovarian dominance which is associated with a non-cyclical pattern of ovarian function. The end result would be the increased androgen production in the ovary and the increased peripheral (non-ovarian) production of oestrogen. There is no real confirmation of this suggestion. Another suggestion has been that there is a familial or genetic role in some cases.

The clinical picture and possible causes of the syndrome are so variable that there is good reason to doubt its being a clinical entity. Or, at least, to conclude that many differing syndromes are at present being included under one heading. Any process capable of producing a cyclical oestrogen production will produce clinical and endocrine features resembling the PCOS. Three minimum criteria for the diagnosis of PCOS are menstrual irregularity; evidence of hyperandrogenism, clinical (hirsutism, acne, male pattern balding) or biochemical (elevated serum androgen level); the exclusion of other diseases. Examples of these include Cushing's syndrome, androgen-producing tumours of the adrenal or ovary, and congenital adrenal hyperplasia.

The objectives of therapy are to reduce endometrial hyperplasia, to control hirsutism and to induce ovulation (if fertility is required).



**Figs 37.7A and B:** The polycystic ovary syndrome in a girl aged 12 years who complained of secondary amenorrhoea and hirsutism (A) Hirsutism of the face and neck, (B) The arms are hairy but the breasts are exceptionally well developed with a suggestion of Montgomery's tubercles on the areola. Good bust development, despite other evidence of defeminisation, is characteristic of the syndrome (see text). (By permission of the Editor, *Am J Obstet Gynecol*)

If an amenorrhoeic patient does not wish to become pregnant and is not bothered by hirsutism, the long-term problem of endometrial hyperplasia remains, for which a progestogen (e.g. medroxy-progesterone acetate 10 mg/day) for 10-14 days every 6-8 weeks will produce withdrawal bleeding as well as reduce endometrial hyperplasia. In some patients, progestogen may need to be administered for 20 days in each cycle.

Hirsutism can be improved by suppression of ovarian function or by increased binding of circulating androgen. Both are achieved by giving a combined oestrogen-progestogen contraceptive pill, preferably one of the newer progestogens.

Medical and surgical methods of induction of ovulation in the infertile patient have been discussed in Chapter 5. It is again emphasised that these ovaries are very easily overstimulated. Metformin administered to those patients who have hyperinsulinaemia improves the outcome.

### *Uterine Amenorrhoea*

Amenorrhoea is not difficult to understand if the uterus is congenitally absent or has been removed at operation, if it is grossly underdeveloped or damaged by radiotherapy. It can even result from heavy curettage in the presence of postabortal infection - *Asherman's syndrome*. Sometimes the endometrium is completely destroyed by infection and inflammation, as in the case of tuberculous endometritis.

### Other Aetiological Factors

Every case of amenorrhoea, physiological or pathological, is explained by one or other of the above mechanisms but they can be brought into play by many factors other than those mentioned.

### Endocrine Disorders

#### *Thyroid*

Hypothyroidism and hyperthyroidism can both depress ovarian and menstrual functions. The latter never causes amenorrhoea unless exophthalmos is present. When hyperthyroidism is associated with amenorrhoea, it is necessary to recognise that it may be merely a manifestation of a pituitary fault which is also the cause of the menstrual upset. Hypothyroidism is associated with an increase in thyrotrophin-releasing hormone

which, in turn, may be associated with a raised prolactin level and hence amenorrhoea.

#### *Pancreas*

Diabetes mellitus which commences in childhood and adolescence causes, or is associated with, amenorrhoea if not controlled.

#### *Adrenal Cortex*

Congenital adrenal hyperplasia or tumour formation results in amenorrhoea (*see* Figs 14.30 and 37.8). In these conditions it is accompanied by other evidence of virilism.

The administration of corticoids to women with normal ovarian and menstrual cycles sometimes causes amenorrhoea. Amenorrhoea and failure to ovulate are, on the other hand, sometimes seen in Addison's disease (total adrenal failure), and can then be cured by giving corticosteroids.

### General Constitutional Upset and Disease

#### *Any Acute Illness*

Such conditions can cause a short period of amenorrhoea.

#### *Chronic Diseases*

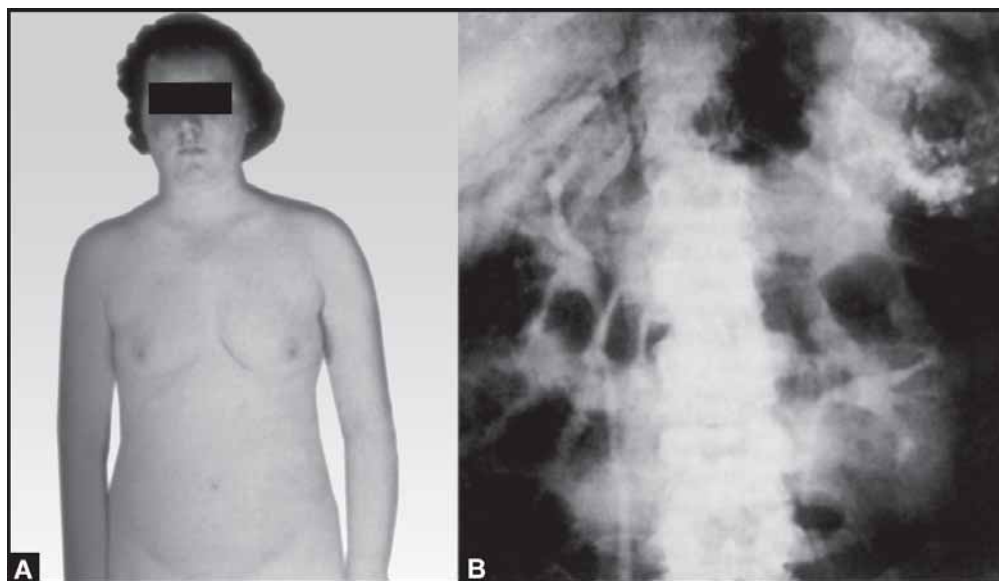
These cause more lasting suppression of menstruation. It is particularly seen in tuberculosis, lymphoma and Crohn's disease. However, anaemia never causes amenorrhoea.

#### *Nutrition*

*Malabsorption syndrome:* Gross and prolonged dietetic deficiencies during childhood are alleged to cause amenorrhoea, which can be permanent, in later life. Such a happening after the deficiency has been corrected must be rare but it has been called *alimentary castration*.

Malabsorption syndromes such as steatorrhoea can cause amenorrhoea which is associated with demonstrably reduced activity of the anterior pituitary.

*Starvation:* Starvation in the adult, such as can occur during wars and famines, can also be followed by suppression of menstruation. Although proteins are essential to the production of gonadotrophins, no special article of food is usually concerned; it is a general deficiency that seems to operate.



**Figs 37.8A and B:** Amenorrhoea as part of Cushing's syndrome caused by an adrenal cortical tumour. This girl, aged 22 years, complained of secondary amenorrhoea and increasing weight. She had slight hypertension in addition to obesity with striae on the hips and flanks. The radiograph shows a calcified tumour of the left adrenal displacing the kidney downwards. The tumour proved to be malignant and the patient died from metastases 6 months after its removal

There is good reason to doubt, however, whether it is lack of food or the stress of the situation that is more important. Thus, women in concentration camps during wartime often quickly develop amenorrhoea. Yet, later, when they are really suffering from the effects of starvation, menstruation may return. This is because they have become emotionally conditioned to their adverse circumstances. Starvation amenorrhoea may therefore derive from the cerebral cortex rather than from the faulty nutrition; no doubt both are concerned.

*Anorexia nervosa:* This is a syndrome resulting from a girl or woman deliberately starving herself. It is mostly seen in teenagers and women in their twenties but can occur much later (Fig. 37.9). In minor degrees, when the only features are amenorrhoea accompanied by moderate loss of weight, it is much more common than is generally realised.

The classical picture is one of secondary amenorrhoea in an extremely emaciated patient whose weight is between 25 and 45 kg, the weight loss being about 25 per cent of the body weight or 15 per cent below the normal for her age and height. The patient is of lively disposition, insisting that she is well and being reluctant to take medical advice. She says she is eating normally and often deceives observers by hiding food or making

herself regurgitate. Sometimes she attempts meals but finds it impossible to continue because of flatulence and distension. Constipation is the rule.

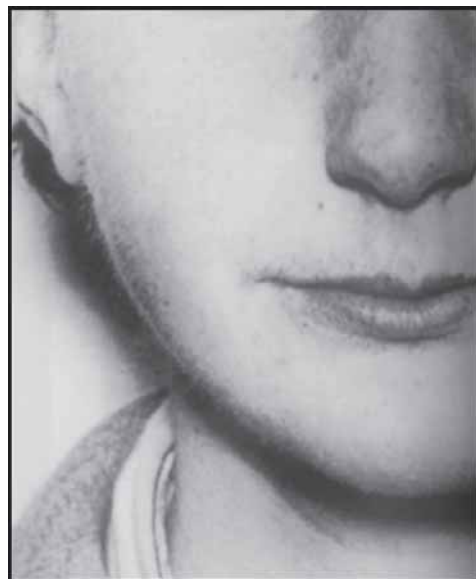


**Fig. 37.9:** Anorexia nervosa in a woman aged 41 years whose only complaint was amenorrhoea for 5 years. She weighed 30 kg. Treatment of various kinds during several years proved ineffective and the cachexia ultimately resulted in a spontaneous fracture of the neck of one femur and, later, in a similar accident on the other side

Although alert, affected girls and women have bradycardia, hypotension and cold blue extremities. An interesting and diagnostic sign is a growth of fine downy hair on the face, trunk and limbs (Fig. 37.10); it is said that this represents a lower-animal reflex to cold and a sluggish metabolism. The whole of the genital tract is generally atrophic. The ovaries lie dormant but can be stimulated to ovulate with gonadotrophins. Diabetes insipidus may develop.

Although free thyroxine levels and adrenal functions may remain unaffected, the levels of gonadotrophins and oestradiol are very low. An observation of great significance is that the administration of GnRH brings about the secretion of gonadotrophins. The hypothalamus must therefore be at the root of the trouble. Some might argue that it is a hypothalamic disturbance which causes the loss of appetite but most clinical observations indicate that the refusal to eat is deliberate or the result of an emotional upset.

It has been suggested that sufferers from anorexia nervosa have a frank psychosis such as schizophrenia. A few may develop these ultimately but the disease



**Fig. 37.10:** This photograph shows the growth of fine downy hair on the cheek of a woman suffering from anorexia nervosa. This is a characteristic finding and the down appears also on the trunk and limbs. The patient was aged 22 years and unmarried. Her only complaint was secondary amenorrhoea for 2 years but she admitted to considerable loss of weight. The background of the trouble was a desire to escape responsibility for the care of her parents

usually starts as a bad habit consequent to unnecessary and 'crash' dieting in adolescence, or represents a 'self-destructive flight' from problems and responsibilities. It can also represent a subconscious desire to attract attention.

In all cases it is the underlying psychological factor which is the cause of the hypothalamic upset. Unless this is eliminated, the amenorrhoea persists, even though the patient resumes eating and recovers her weight. However, weight gain indicates emotional recovery and menstruation usually resumes when a critical weight for the individual patient is achieved.

Anorexia nervosa is very resistant to treatment and is a serious condition. It is said to have an ultimate mortality rate of 7-10 per cent. Death often comes suddenly from myocardial failure which is the result of either muscle atrophy, paralysis associated with hypokalaemia, or occult (and therefore untreated) but severe infection.

*Bulimia nervosa:* Amenorrhoea can be caused by overeating as well as undereating. Bulimia nervosa is marked by secretive, episodic binge eating followed by self-induced vomiting and fasting. It is also seen in young women but is rarer than anorexia nervosa. Episodes of bulimia may be seen in anorectics. There is a high incidence of depression in bulimics, the aetiology of which may lie in family problems. The body weight fluctuates.

*Obesity:* Amenorrhoea is often associated with obesity. This combination might be regarded as two-pronged evidence of a primary hypothalamic disease but it rarely is. Nor is the obesity usually explained by some metabolic error or 'hormone upset' which the patient likes to suppose. While recognising that some girls and women (and men) 'run to fat' easily because of their inherent type of metabolism whereas others always remain thin, the fact remains that obesity is always the result of an unnecessarily large intake of food for that particular individual. Moreover, whatever its cause, it can always be corrected by a low calorie intake and if it is, the associated amenorrhoea disappears spontaneously.

It is of interest to study fat children and adults in public places such as airports and railway stations. They are always eating — sweets, sandwiches, ice cream or something — no matter whether they are sitting, standing or walking. Yet, if asked in the consulting room, they always deny that they eat more than others.

Children can acquire the habit of overeating by following the practice of parents and other members of the family. Some mothers cannot resist giving their children the best of everything, doing so with the best of intentions.

### Environment

Changes of climate, of occupation and of living conditions frequently cause amenorrhoea in susceptible women, operating through the psyche and the hypothalamus. Work involving institutional life, long hours of study and worry over examinations is particularly prone to have this effect. From 25 to 50 per cent of student nurses and resident college students develop short periods of amenorrhoea at some time during their training. Air hostesses on international routes commonly have a similar problem until they become acclimatised to rapidly changing environments.

### Exercise-related Amenorrhoea

Exercise-related amenorrhoea is being noted more frequently especially in long-distance runners. Detailed studies reveal low gonadotrophins and low oestrogens, but impaired LH secretion is suggested as a primary factor in the amenorrhoea. Altered diet, weight loss and stress are also factors in many amenorrhoeic athletes.

### Investigation

It is never justifiable to treat amenorrhoea without first making an attempt to determine its cause and to assess its significance; and care is required in deciding when, and to what extent, amenorrhoea should even be investigated. This is especially true for primary amenorrhoea in young girls who are so often suffering merely from a late onset of what will prove to be an otherwise normal menarche. If there is doubt about such a case, no harm comes of waiting. Delay in instituting treatment does not prejudice the ultimate result as regards either menstrual or reproductive functions. The following general rules can be applied in practice.

If menstruation has not commenced by the age of 16 years, an examination should be carried out to exclude systemic disease and stigmas of gross endocrine dysfunction, and also to make sure the case is not one of cryptomenorrhoea. If any of these is found, detailed investigation is indicated at once. If the physical and

sexual developments appear normal, nothing further need be done except to advise the girl on diet, exercise, work, leisure and health in general. If, however, menstruation has not commenced by the age of 18 years, further investigation should be arranged.

The avoidance of *unnecessary* investigation and overenthusiastic treatment is equally important in older patients. When amenorrhoea is of short duration and appears to be associated with a temporary physical or mental upset, or with a change of environment, it is usually wise to await a spontaneous cure. On the other hand, when there is no reasonable explanation for the cessation of menstruation, the fullest possible investigation should be instituted before any conclusion is reached.

### Clinical Examination

This is the most valuable of all investigations. A clear guide to the cause of amenorrhoea can often be deduced from a careful family and personal history of the patient, and from the presence or absence of associated symptoms. The age of the patient and the previous menstrual habit are important. Was the onset of amenorrhoea dramatic or preceded by oligomenorrhoea? Has there been an increase or decrease in weight, or any change in the voice? Is the woman pregnant? Has she been taking oral contraceptives? Is there any evidence of galactorrhoea? Amenorrhoea due to primary ovarian failure, especially if it comes on after a phase of normal ovarian activity, is accompanied by an outpouring of excessive amounts of gonadotrophin by a pituitary released from oestrogen inhibition; this results in climacteric symptoms. Hypothalamic, pituitary and uterine amenorrhoea, on the other hand, are not associated with menopausal flushes. These *never* occur, for example, in Sheehan's syndrome or anorexia nervosa. The answer to a simple question on this matter is of great value in elucidating the cause.

The stature and build of the patient should be noted. The development of the breasts and of other secondary sex characters is assessed. If this is normal for the age, primary amenorrhoea is almost certainly due to absence or gross underdevelopment of the uterus, or to cryptomenorrhoea. The vulva and vagina reflect accurately the functional capacity of the ovaries. The presence of the uterus may be indicated by vaginal or rectal examination.



## Special Investigations

Whenever the clinical features and simple tests do not reveal a clear cause for the amenorrhoea, and sometimes when they apparently do, special investigations are indicated. These include the following and the choice rests on the circumstances of each case.

### Tests for Pregnancy

These are advisable whenever the amenorrhoea is secondary and of short duration.

### Radiology

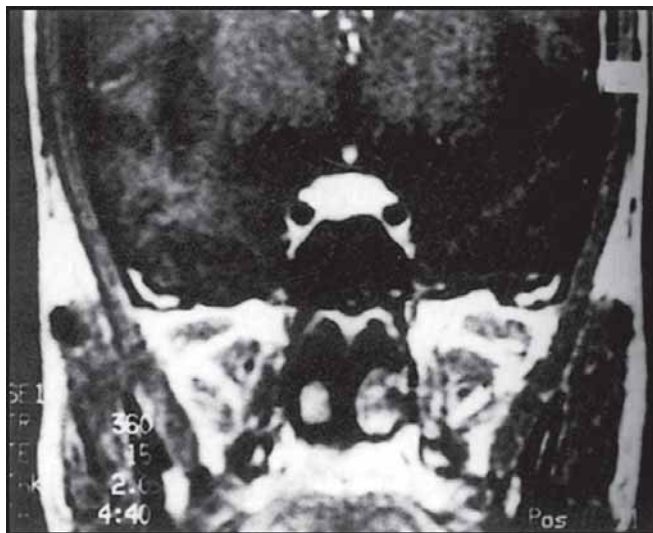
Radiological examination of the pituitary gland is recommended in all cases. A coned-down view of the sella was done in cases of galactorrhoea. More detailed studies are required if this is abnormal or the prolactin level is significantly raised. Small pituitary adenomas are best detected by CT scan or MRI (Fig. 37.11).

### Ophthalmology

Examination of the retina and visual fields should be done if a pituitary tumour is suspected.

### Urinalysis

A check for glycosuria should be carried out and, if possible, a glucose tolerance test.



**Fig. 37.11:** T<sub>1</sub> weighted coronal MR image after gadolinium enhancement showing a right sided hypointense lesion in the anterior lobe of the pituitary gland, suggesting pituitary microadenoma

### Hormone Assays

These aim to cover pituitary, thyroid, adrenal and gonadal function. If facilities are available the plasma levels of FSH, LH and prolactin should be determined and thyroid function tests (TSH, free T<sub>3</sub>, T<sub>4</sub> levels) carried out; other tests may be indicated on clinical grounds or following initial test results.

If the level of gonadotrophins is raised it strongly suggests a primary ovarian fault; if it is lowered, the trouble lies in the hypothalamic-pituitary system. Evidence of adrenal, cortical or thyroid dysfunction may call for supplementary tests involving suppression or stimulation of the particular gland. These show whether the upset is primary or secondary and also help to exclude tumour formation. Serum FSH levels are required to determine whether the patient has hypergonadotropic, hypogonadotropic, or eugonadotropic amenorrhoea. A circulating FSH level of >40 mIU/ml indicated on at least two blood samples is indicative of hypergonadotropic amenorrhoea. Hypergonadotropism signifies that the cause of amenorrhoea is at the level of the ovary.

In patients less than 30 years of age with hypergonadotropic amenorrhoea, a karyotype is required to rule out the presence of a Y cell line.

It is important to identify Y chromosomal material so it may be removed to prevent malignant degeneration.

There is much debate regarding the extent of an autoimmune workup required for a patient with ovarian failure.

### Chromosome Studies

The sex chromatin pattern is determined by the examination of buccal smears and the sex chromosome makeup by culturing leucocytes or skin (*see* Chapter 14). These investigations are essential if the amenorrhoea is primary but rarely when it is secondary and the patient has no other physical stigmata.

### Ultrasound

Ultrasound is used to document the presence of the uterus and ovaries and to study their morphology. This is useful in cases of primary amenorrhoea to rule out congenital anomalies; to see the thickness of the endometrial echo which reflects the oestradiol level and to evaluate the size of the ovaries, the number and arrangement of the follicles and the appearance of the

stroma. In a case of polycystic ovaries, the follicles are arranged around the periphery with stromal hyperplasia (Fig. 37.12).

In hypoestrogenic states, e.g. anorexia nervosa, the endometrial thickness is less than 4 mm; the converse obtains with prolonged unopposed oestrogen stimulation and endometrial hyperplasia. The widespread availability of ultrasound, aided by the development of MRI, laparoscopy and hormone assay, has almost done away with the need for examination under anaesthesia in cases of amenorrhoea.

### Laparoscopy

This is done to exclude the presence of streak gonads, testes and small ovarian tumours, and to recognise polycystic ovaries. Abnormal gonads can be removed at the same sitting. Polycystic ovaries can be 'drilled' if medical treatment has been unsuccessful.

### Therapeutic Tests

When investigations leave doubt as to which link of the hypothalamus → pituitary → ovary → uterus chain is primarily at fault, therapeutic tests are of great value. The first of these is to assess uterine sensitivity to ovarian hormones. After excluding pregnancy, hyperprolactinaemia and hypothyroidism, a progestogen challenge test is administered: 10 mg medroxyprogesterone acetate daily for 5 days, or 200 mg parenteral progesterone. The former is generally preferred. If the patient has a withdrawal bleeding it indicates the presence of a functional outflow tract and also the presence of sufficient circulating endogenous oestrogen which has

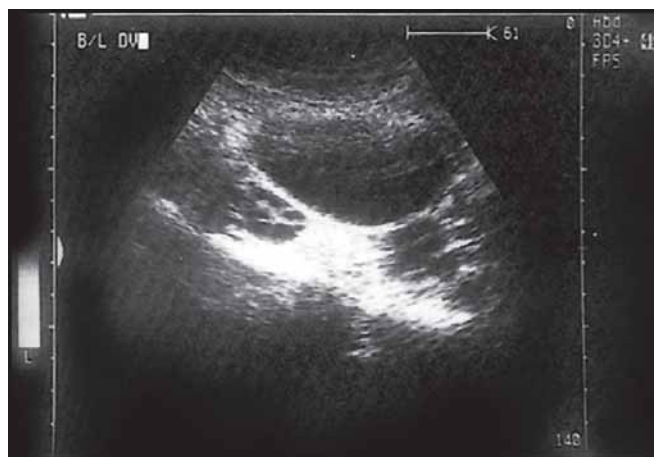


Fig. 37.12: Polycystic ovary seen on ultrasound

'primed' the endometrium, and the diagnosis is anovulation.

If, on the other hand, the patient does not have withdrawal bleeding in response to the progestogen challenge, a combination of oestrogen and progestogen is given, either sequentially using conjugated oestrogens for 20 days with medroxyprogesterone acetate in the last 10 days; or, a combined oral contraceptive pill is administered daily for 21 days. If there is still no bleeding, the course is repeated. A negative response indicates a defect in the outflow tract, i.e. uterine amenorrhoea. If, however, bleeding does occur, it points to a defect in production of both oestrogen and progesterone.

Serum FSH and LH levels are measured. If these are raised, the cause is ovarian failure, whereas if they are low or normal, the cause is hypothalamic.

### Treatment

#### Treatment of the Cause

The treatment of amenorrhoea is largely dependent on its cause. If this is due to some general disease such as diabetes, that alone requires treatment. Pelvic tuberculosis calls for antituberculous drugs. An adrenal cortical adenoma or an androblastoma of the ovary can be removed and menstruation, even if it has been suspended for many years, quickly and spontaneously returns. Equally good results sometimes follow the treatment of psychological disturbances and systemic disease but this is by no means the rule. Young women persuaded to discontinue a strict reducing diet may have to wait a long time before their menses return. Environmental amenorrhoea can be very persistent. In all such instances, however, it is more than likely that the underlying psychological or other cause is not corrected to the extent suggested by other features of the case.

*Anorexia nervosa* is particularly difficult to treat successfully, the prognosis depending to some extent on the duration of the syndrome. Hospitalisation, often for as long as 2 to 3 months, and sometimes including isolation, is essential. In hospital, the approaches vary. One of the most common approaches is 'behaviour modification'. This involves withdrawal of privileges and a step-wise reinstatement of these in reward for weight gain. The patient is encouraged to consume a minimum of 2600 kcal/ day. Some physicians advocate forced feeding supplemented by psychiatric measures; others aim to eliminate the patient's inhibition by giving

large doses of tranquillizers such as chlorpromazine over long periods. Gentle and considerate counselling and an explanation of the problem to the patient is, however, often sufficient to stimulate patient response. Even though the patient responds well to institutional care, she requires regular supervision and psychiatric support thereafter. Despite this, however, relapse is common and readmission to hospital becomes necessary in one-third of the cases. If amenorrhoea persists when nutrition has been improved, ovulation for conception can be induced with gonadotrophin therapy and sometimes with clomiphene. Pregnancy is well tolerated and may help in the cure.

### General Treatment

This includes the correction of errors in diet, working conditions, home environment and the use of leisure. When amenorrhoea is associated with obesity, reduction of weight can *always* be achieved by strict adherence to a low-calorie diet. An intake of not more than 1000 kcal a day will cause a loss of 15-20 kg in 3 months; if it does not, then the patient has departed from instructions. Lest she becomes discouraged, she should be warned that loss of weight is often not apparent until after the first 2 or 3 weeks of treatment.

It is remarkable that weight reduction alone is not infrequently followed by cure of amenorrhoea and oligomenorrhoea, and this is true even when the woman presents features of a recognised syndrome such as PCOS. Associated with weight reduction and loss of adipose tissue is altered oestrogen metabolism as is a change in the function of the adrenal cortex.

In a large number of cases in which the amenorrhoea is not the result of organic disease, for example, when it reflects a temporary derangement of the neuroendocrine system caused by environmental or other factors, it cures itself spontaneously. Such an outcome should always be awaited before resorting to hormone or other special treatment.

Meanwhile, it is important to give the patient a rational explanation of the state of affairs and to reassure her of the harmlessness of amenorrhoea from the standpoint of general health. Ancient myths die slowly, and it is still common for women to fear that what they regard as a failure to excrete noxious materials will lead to ill health. The basis of these fears is the long-known association between amenorrhoea and ill-health;

unfortunately the laity reverse the cause-and-effect relationship.

### Hormone therapy

#### Thyroid

Although only a few patients with amenorrhoea will be diagnosed to have hypothyroidism, the replacement of thyroxine in these women produces a dramatic relief in symptoms.

#### Corticosteroids

These, in the form of prednisone, prednisolone or dexamethasone, cure amenorrhoea which is a feature of congenital adrenal hyperplasia. But they are rarely of value when given empirically. The rare dramatic successes attending such 'blind' therapy are explained by the amenorrhoea being the result of latent undiagnosed adrenal failure (Addison's disease) or polycystic ovaries.

#### Oestrogen and Progestogen

Cyclical treatment with oestrogens and progestogens can be given for up to three cycles as a diagnostic measure to test uterine reactivity. In most cases, especially when amenorrhoea is primary, menstruation ceases as soon as treatment is withheld.

One has to remember that the use of oral contraceptive preparations is *relatively contraindicated* in patients with amenorrhoea or oligomenorrhoea because it temporarily masks the symptom and is then followed by 'post-pill amenorrhoea'.

It is sometimes advised that oestrogen therapy should not be commenced until it is reasonably certain, by radiological study of the bony epiphyses, that no more physical growth is to be expected. In fact, oestrogens probably play little part in closing epiphyses; they can even cause a spurt in physical growth, such as is normally seen at puberty.

If the effect of cyclical oestrogen-progestogen therapy proves to be only temporary so far as uterine bleeding is concerned, and the amenorrhoea appears to be constitutional, it should not be continued indefinitely merely to produce what the patient regards as menstruation.

When primary amenorrhoea is associated with infantilism and poorly formed secondary sex characteristics, as in cases of streak gonads and intersex,

a reason for giving oestrogens (along with progestogens) over long periods is to promote facial maturity, breast development and the growth of body hair. Oestrogen will also develop the vagina to permit satisfactory coitus. This hormone does not always succeed in these objectives, especially so far as body hair is concerned. In these patients and in cases of premature ovarian failure, long-term oestrogen and progestogen therapy is recommended to avoid the problems of osteoporosis.

### *Clomiphene*

Clomiphene is only effective when the hypothalamic-pituitary system is capable of function. The likelihood of response to clomiphene is determined by the basal oestrogen level. Its main indication is infertility (with amenorrhoea) associated with PCOS, post-pill amenorrhoea and the Chiari-Frommel syndrome. Some women with post-pill amenorrhoea who have no other cause for their amenorrhoea ovulate following a single course of clomiphene, hence the descriptive term clomiphene-responsive amenorrhoea. This is preferable to the term hypothalamic amenorrhoea for there is no evidence of a hypothalamic disorder although hypothalamic function is suppressed.

### *Gonadotrophins*

These are indicated only when the overriding complaint is infertility, and when anovulation is caused by a proven failure in pituitary function, as shown by a persistent low output of gonadotrophins, and when the gonads contain responsive ova. The effect of this treatment is limited to the period of its application, the details of which are in chapter 5.

### *Clomiphene Andgonadotrophins*

See chapter 5.

### *Gonadotrophin Releasing Hormone Agonists*

Induction of ovulation by gonadotrophin releasing hormone agonists has an important place in the treatment of infertility and amenorrhoea whose basic cause lies in the hypothalamus and cerebral cortex.

### *Agents Influencing the Hypothalamus*

Amenorrhoea with a hypothalamic basis, such as that associated with the taking of oral contraceptives and

hyperprolactinaemia, sometimes responds well to L-dopamine.

More often used in these circumstances is bromocriptine, which can have a dramatic effect restoring ovulation as well as menstruation while suppressing lactation. This ergot alkaloid is effective even in cases of pituitary tumour (for actions and dosage).

## Surgical Treatment

See chapter 5.

## Results

It is difficult to assess the overall results of treating amenorrhoea because its causes are so many and varied, some amenable to appropriate treatment, some not. If replacement therapy of one kind or another results in isolated episodes of ovulation and menstruation, or even in pregnancy, without restoring the cycle, is this to be regarded as a cure?

Moreover, many 'cures' of amenorrhoea of uncertain origin are spontaneous and independent of treatment. Thus, although *primary* amenorrhoea in women aged more than 20 years is rarely treated successfully, no matter what method is employed, in those who are younger the results are better because in many the menses would have started spontaneously had they been given time.

Similarly, in *secondary* amenorrhoea the prognosis depends to some extent on its duration; this usually means that the longer the amenorrhoea, the less likely is a spontaneous cure. In the majority of cases, investigation will reveal a cause and appropriate therapy can be instituted. Among cases for which no organic cause is found, the results for psychotherapy, oestrogens, progestogens, thyroxine, corticosteroids, ovarian resection or drilling and, indeed, for no treatment at all, are identical — a 60 per cent cure rate for secondary amenorrhoea of 1-2 years duration.

Pessimism is generally unwarranted and it is extraordinary how often menstruation returns sooner or later, or even begins when least expected. I know of three cases in which *primary* amenorrhoea cured itself spontaneously between the ages of 25 and 27 years and two of the women concerned proved highly fertile; the third was unmarried.

Let this section conclude with a case which illustrates a *common* situation.

A medical student presented with amenorrhoea of 1 year's duration. The uterus was rather small but the physical signs were otherwise unremarkable; her early life had been unhappy, she had been dieting unnecessarily and was studying hard. A therapeutic test with cyclical oestrogens failed twice but produced a feeble response on the third occasion. The girl was told that general factors were responsible and was seen annually. Menstruation returned unexpectedly on the first day of her written final examination papers.

She had infrequent periods in the following years but despite this she ovulated spontaneously, for she subsequently had three children without difficulty. This was despite a gloomy outlook given by gynaecologists in other cities she worked in and emphasis on the necessity of drugs to induce ovulation.

The diagnostic workup is summarised as follows:

1. Assessment of the serum FSH level should be performed as the initial laboratory test unless the history and physical examination suggest otherwise. The FSH level differentiates hypergonadotropic and hypogonadotropic forms of hypogonadism. If the FSH level is elevated, a karyotype is obtained. An elevated FSH level in combination with a 45, X karyotype confirms the diagnosis of Turner's syndrome. Partial deletion of the X chromosome, mosaicism, pure gonadal dysgenesis, and mixed gonadal dysgenesis are diagnosed by obtaining a karyotype.
2. Because of the association of coarctation of the aorta and thyroid dysfunction, patients with Turner's syndrome should undergo echocardiography and thyroid function studies.
3. If the karyotype is normal and the FSH is elevated, it is important to consider the diagnosis of 17 $\alpha$ -hydroxylase deficiency because it may be a life-threatening disease, if untreated. This diagnosis should be considered when testing indicates elevated serum progesterone levels (>3 ng/ml), a low 17 $\alpha$ -hydroxyprogesterone level (<0.2 ng/ml), and an elevated serum deoxycorticosterone (DOS) level. The diagnosis is confirmed with an ACTH stimulation test. After ACTH bolus administration, affected individuals have markedly increased levels of serum progesterone compared with baseline levels and no change in serum 17 $\alpha$ -hydroxyprogesterone levels.
4. If the screening FSH level is low, the diagnosis of hypogonadotropic hypogonadism is established.

5. If the history suggests the presence of a central nervous system lesion or galactorrhoea, imaging of the head using computed tomography (CT) or magnetic resonance imaging (MRI) is helpful in the diagnosis. Suprasellar or intrasellar calcification in an abnormal sella is found in approximately 70 per cent of patients with craniopharyngioma.

Physiologic delay is a diagnosis of exclusion that is difficult to distinguish from insufficient GnRH secretion. The diagnosis can be supported by a history suggesting physiologic delay, a radiograph showing delayed bone age, and the absence of a central nervous system lesion on CT or MRI scanning. Gonadotropin-deficient patients can usually be distinguished from patients with physiologic delay by their response to GnRH stimulation. Patients with physiologic delay have a normal LH response to GnRH stimulation for their bone age, in contrast with gonadotropin-deficient patients, in whom the LH and FSH responses are low.

## HYPOMENORRHOEA

### Definition

Uterine bleeding may be slight in amount, short in duration, or both, but the menstrual function varies so widely within normal limits that the definition of an abnormally scanty loss is a matter of opinion. Bleeding which lasts 2 days or less is unusual, if not pathological, and is termed *hypomenorrhoea*.

### Causes

#### *Constitutional*

In most cases scanty menstruation characterises the whole menstrual life of a woman and is to be regarded as a constitutional trait of no significance. Even when it precedes or follows a phase of full menstrual loss, it rarely has a pathological basis. Bleeding which lasts only a few hours is not incompatible with full fertility, the ovarian and endometrial cycles usually being normal.

Constitutional scanty menstruation is perhaps best explained by assuming the presence of an unusual arrangement, or relative insensitivity, of the endometrial vascular apparatus.

#### *Uterine*

Scanty loss *sometimes* means that the bleeding surface is smaller than normal, and is occasionally seen when the

endometrial cavity has been reduced too much during myomectomy or other plastic operation on the uterus, by intrauterine adhesions or by chronic endometritis, e.g. tubercular. The finding of endometrial tuberculosis almost always means that the tubes are infected, although not necessarily closed. The endometrium is involved in approximately 50-60 per cent of women with genital tuberculosis. On hysteroscopy, synechias are present in 25 per cent of patients of whom 40 per cent may have positive endometrial biopsy. Therefore a hysteroscopic examination should be performed routinely, before admitting patients with genital tuberculosis into an IVF program. The preliminary evaluation reduces the failure rate and increases the cancellation rate. A history of tubercular endometritis represents a special indication for a preliminary hysteroscopy before IVF. Preferred treatment for synechias is lysis of adhesions at hysteroscopy, followed by immediate insertion of an intrauterine device to prevent further adhesions. Use of oestrogens or a combination of oestrogen and progestogen for rapid endometrial growth has been controversial. The success of treatment regarding term deliveries and rate of abortions depend on the severity of adhesions. The treatment consists of initial multidrug medical therapy for a period of 6 months to 1 year. Pregnancy after a diagnosis of genital tuberculosis is rare and when it does occur, it is more likely to be an ectopic one or result in spontaneous abortion.

#### *Hormonal*

Disturbances of the endocrine system do not ordinarily lead to scanty menstruation without altering the cycle at the same time (*see oligomenorrhoea*). Scanty menstruation is, however, occasionally seen as a forerunner to amenorrhoea and then has the same causes. It can also occur with long-term use of low-dose oral contraceptives, as a result of progressive endometrial atrophy.

#### *Nervous and Emotional*

Psychological factors may fail to suppress a stable ovarian and uterine cycle completely and sometimes succeed only in reducing the amount of flow. The best example is pseudocycsis which is frequently characterised by scanty periods rather than amenorrhoea.

## Treatment

Unless a significant causal abnormality is found, no treatment other than reassurance is necessary. So far as health and fertility are concerned, it usually does not matter whether menses last half an hour, half a day or half a week.

## OLIGOMENORRHOEA

### Definition

Oligomenorrhoea can only be defined arbitrarily as one in which the cycle lasts longer than 35 days. Menstruation may be both infrequent and irregular, or may be regularly infrequent. In either case the error is in the ovary and its controlling factors, rather than in the uterus; for this reason the symptom tends to have more significance than does hypomenorrhoea. *Infrequent menstruation and amenorrhoea are essentially similar symptoms with identical causes*—the difference is only one of degree. Indeed, when menstruation only occurs at intervals of 3 or more months, it is a matter of opinion as to whether the condition is described as one or the other.

### Causes

#### *Constitutional and Physiological*

In the majority of cases infrequent menstruation represents a peculiarity of the individual and is not out of keeping with health and good fertility. It can be familial. The bleeding can be ovular in type, which means that the ovarian cycle is drawn out or temporarily arrested at some phase. As a rule the luteal phase tends to be fairly constant at 14 days; it is the follicular phase which is either lengthened or slow to commence.

Infrequent menstruation sometimes follows the menarche and precedes the menopause; it then marks a gradual waxing and waning of the endocrine cycle, and is physiological. Adolescent oligomenorrhoea tends to cure itself within a few years but may persist until the first pregnancy, after which it is often replaced by a more normal cycle.

#### *Hormonal*

*If there is any abnormality* it is essentially one in which the ovary is underactive, and this is reflected in the

secondary sex organs. Hypoplasia of the uterus and vagina, and a history of a late menarche, are therefore to be expected. The ovarian disturbance is often secondary to hypothalamic, pituitary, thyroid or adrenal dysfunction, so the patient may have other stigmas of endocrine upset such as obesity, squat figure, hirsutism and low fertility. Obesity and oligomenorrhoea are close companions. So are oligomenorrhoea and hirsutism, but the basis may still be genetic and familial. Otherwise these combinations may be part of the PCOS.

### *Chromosomal*

An underlying sex chromosome abnormality, such as an XXX arrangement, is occasionally found.

### Treatment

The investigation and treatment of oligomenorrhoea are the same as those for amenorrhoea, but the prognosis is better because gross abnormalities of the ovary and uterus are less likely to be present. There is no need for any treatment except reassurance in the majority of cases, that is, those in which the condition appears to be constitutional and is unassociated with impaired fertility. Over treatment should also be avoided, particularly in young girls in whom a spontaneous cure can be expected.

If, in addition, infertility is a problem, treatment may be required to induce or increase the frequency of ovulation. Counselling regarding the time of intercourse is difficult with erratic or infrequent menstrual cycles.

# Abnormal and Excessive Uterine Bleeding

Clinical Types	598
Causes of Abnormal Uterine Bleeding	599
Diagnosis	605
Special Clinical Types of Bleeding	612

## CLINICAL TYPES

Abnormal uterine bleeding is a symptom and not a disease. It occurs in various forms. A rational approach and accurate diagnosis depend on recognising the following types.

Many causes of bleeding are strongly suggested by the history alone. Note the amount of menstrual flow, the length of the menstrual cycle and menstrual period, the length and amount of episodes of intermenstrual bleeding, and any episodes of contact bleeding. Note also the last menstrual period, the last normal menstrual period, age at menarche and menopause, and any changes in general health. The patient must keep a record of bleeding patterns to determine whether bleeding is abnormal or only a variation of normal. However, most women have an occasional menstrual cycle that is not in their usual pattern. Depending on the patient's age and the pattern of the bleeding, observation may be all that is necessary.

On examination: Abdominal masses and an enlarged, irregular uterus suggest myoma. A symmetrically enlarged uterus is more typical of adenomyosis or endometrial carcinoma. Atrophic and inflammatory vulvar and vaginal lesions can be visualised, and cervical polyps and invasive lesions of cervical carcinoma can be seen.

*Menorrhagia* is cyclical bleeding at normal intervals which is excessive in amount or duration, for example 5/28 or 8/28. It is generally caused by conditions affecting the uterus and its vascular apparatus, rather than by any ovarian disturbance. It occurs if the bleeding surface (that is the area of the endometrium) is increased — by uterine tumours such as leiomyoma and adenomyosis; or it can be a manifestation of a coagulation disorder.

*Polymenorrhoea* is cyclical bleeding which is normal in amount but which occurs at too frequent intervals of less than 21 days, for example 5/21. Here the uterus is likely to be normal and the error in cycle is the result of disease or functional disturbance of the ovary. Polymenorrhoea occurs when pituitary-ovarian relationships are upset, and when there is alteration of ovarian function associated with vasomotor disturbance, pelvic infection and ovarian endometriosis.



*Polymenorrhagia* is cyclical bleeding which is both excessive and too frequent, for example 9/20-12/20. It implies a disturbance in the hypothalamic-pituitary-ovarian-uterine axis plus the uterus itself and the endometrium, and is seen particularly in the presence of pelvic infection and sometimes under high-pressure stress situations.

*Metrorrhagia* is bleeding of any amount which is acyclical and which occurs irregularly or continuously in between normal cycles. This sometimes denotes a profound alteration in the ovarian rhythm but is more often caused by a 'surface' lesion of the genital tract – a benign or malignant growth with ulceration, for example. It is also a feature of abnormal pregnancy states such as abortion and ectopic pregnancy.

According to its name, metrorrhagia always originates in the uterus; in practice, any irregular bleeding which occurs *per vaginam* is often included under this heading – no matter whether it arises from the tube, vagina or the vulva, and even if it is no more than a blood-stained discharge. This chapter, however, is concerned only with bleeding from the *corpus uteri*. Haemorrhage from lesions in the tubes, cervix and lower genital tract is excluded except when it comes to the differential diagnosis of 'special clinical types of bleeding' discussed later.

*Menometrorrhagia* is prolonged and irregular bleeding.

There is an increased tendency nowadays to use the patient's own words regarding abnormal bleeding. It certainly avoids confusion. The distinction between the varieties of abnormal bleeding is not usually as clear cut as the definitions imply and there is a lot of overlap.

## CAUSES OF ABNORMAL UTERINE BLEEDING

Abnormal uterine bleeding may be categorised into two broad categories: the first is due to organic causes; the second is the so-called dysfunctional uterine bleeding, caused usually by anovulation or oligo-ovulation.

### General Systemic Diseases

With the exceptions mentioned below, *chronic illnesses suppress rather than increase menstruation*. Acute pyrexial illnesses, however, sometimes precipitate the onset of a period prematurely.

### Coagulation Defects

Any blood disorder characterised by coagulation defects or by excessive capillary fragility can cause endometrial

haemorrhage. Such bleeding may be one of the *first* manifestations of thrombocytopenic purpura, aplastic anaemia, leukaemias, von Willebrand's disease and Christmas disease, for example, and can be so severe as to threaten life. Anaemia is said to cause menorrhagia but is much more likely to be the effect. Anticoagulants do not necessarily increase the menstrual flow.

Increased fibrinolytic activity of the endometrium is a postulated but unproven cause of menorrhagia. Some observers claim to have demonstrated an increase in fibrin degradation products in the uterine and systemic veins in certain cases; others deny this finding. If the level is raised it is more likely to be the result than the cause of the menorrhagia; that is, the endometrium is being called upon to deal with more clots than normal.

### Endocrine Disorders; Hyperoestrogenism

Hypothyroidism tends to cause menorrhagia or polymenorrhoea, these symptoms being present in 30-40 per cent of cases. Hypothalamic and pituitary diseases cause excessive uterine bleeding or failure of the normal cyclical pattern. This is sometimes seen, for example, in the early stages of acromegaly (Figs 38.1A to F).

Cirrhosis of the liver and chronic renal disease which disturbs the normal metabolism and inactivation of oestrogen and its excretion, can lead to menorrhagia or metrorrhagia.

One of the commonest causes for metrorrhagia and menorrhagia is exogenous oestrogen, administered by various routes for a variety of conditions such as pruritus vulvae, climacteric symptoms, and even for the control of uterine bleeding (*see below*). Tamoxifen therapy for breast cancer is associated with irregular bleeding.

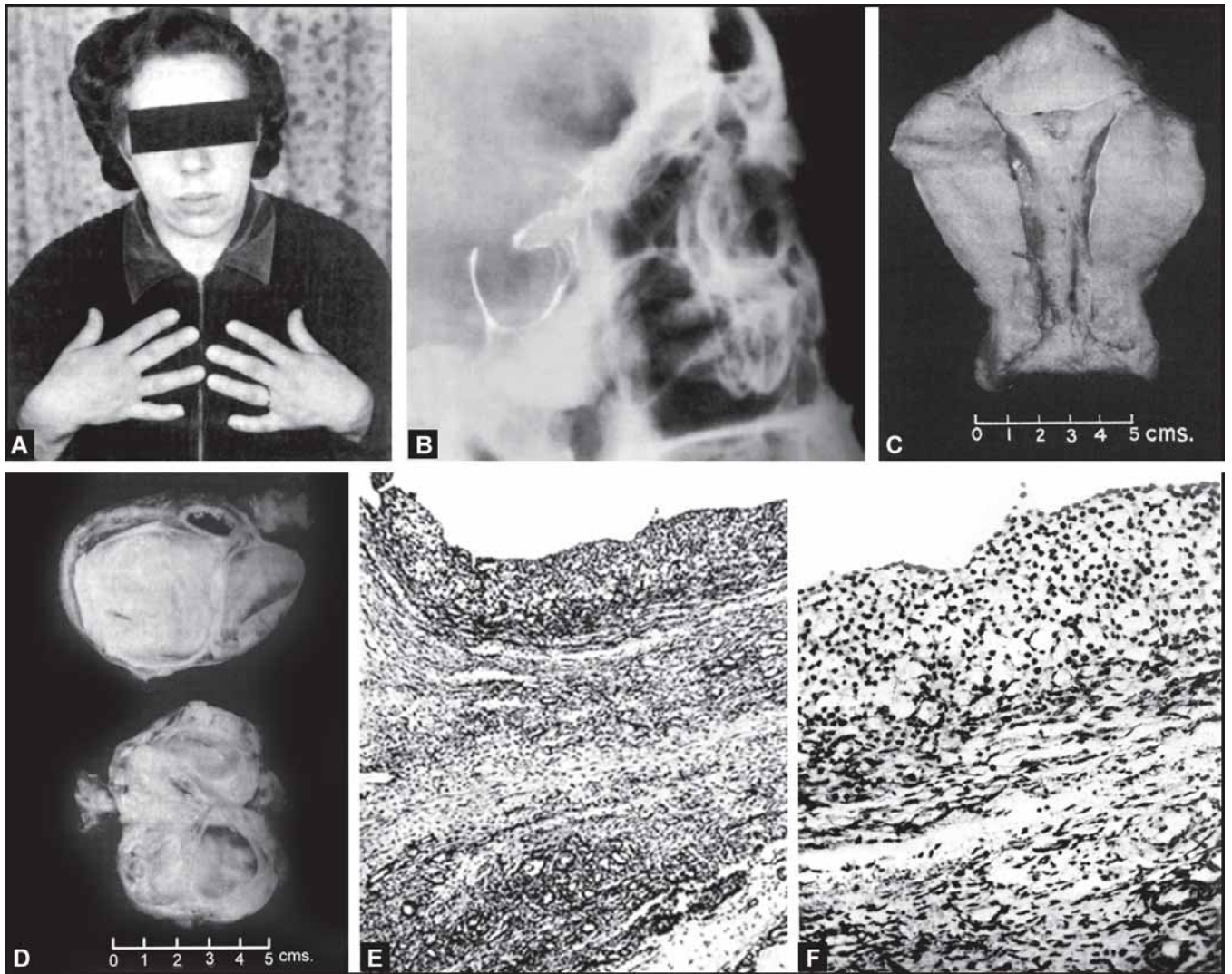
'Breakthrough' and other forms of uterine bleeding can also complicate the taking of combined oral contraceptives and progestin-only contraceptives.

### Pelvic Pathology

#### *Pregnancy States*

The causes of uterine bleeding in *early* pregnancy are implantation bleeding, abortion and gestational trophoblastic disease.

After abortion and labour the uterus is sometimes slow to involute, so the first few menstrual periods tend to be heavy. This is delayed involution and nearly always cures itself in a short time. Very rarely, large vessels in the placental site fail to become obliterated and can then cause severe menorrhagia.



**Figs 38.1A to F:** Abnormal uterine bleeding associated with overstimulation of the ovaries caused by an outpouring of gonadotrophin in a case of acromegaly. This case is unusual in that acromegaly is likely to result in amenorrhoea, ultimately if not initially, (A) The patient, aged 41 years, with evidence of acromegaly for 10 years. During this time she had suffered from polymenorrhagia and this had been very severe for one year. She was found to have generalised enlargement of the uterus and was treated by vaginal hysterectomy and bilateral salpingo-oophorectomy. (B) A radiograph of the skull showing the sella turcica enlarged by the underlying pituitary tumour, (C) The uterus showing generalised myohyperplasia. (D) Bilateral cystic ovaries, (E) The wall of a follicular cyst in one of the ovaries, (F) A higher power photomicrograph of the same cyst showing its lining of granulosa cells with theca outside them

### *Errors in Uterine Development*

Menorrhagia is not uncommonly seen in association with uterus didelphys or bicornis; it presumably occurs because good development of both horns results in an increased bleeding surface.

### *Infections*

All forms of pelvic peritonitis, salpingo-oophoritis and cellulitis tend to cause abnormal uterine haemorrhage. This is generally characterised by a change in cycle because the ovaries are inevitably involved by way of

congestion if not by the infection itself. In the acute phase of the inflammation the menstrual upset is sudden, short-lived and usually not severe; in acute salpingo-oophoritis, for instance, the early or late onset of a heavy and prolonged period is frequently seen. When the infection becomes chronic, polymenorrhagia is to be expected. The only exception to this rule is tuberculous infection which more often leads to amenorrhoea or oligomenorrhoea.

Chronic endometritis used to be frequently blamed for excessive uterine bleeding of one kind or another but it is now clear that this condition is rarely found in the young adult. Tuberculous endometritis can cause bleeding of any type at any age.

Inflammation which does not involve the ovaries or the body of the uterus, e.g. chronic cervicitis, is unlikely to upset menstruation unless cellulitis is present as well, but may cause irregular bleeding, especially contact bleeding. Chlamydial infection is common in such patients.

#### *Local Injury - Foreign Bodies*

Trauma to the interior of the uterus, resulting from the insertion of instruments or domestic articles (usually with the object of inducing abortion) causes a single episode of bleeding. Foreign bodies, such as an intrauterine contraceptive device retained in the cavity can result in either menorrhagia or intermittent or persistent acyclical bleeding and spotting.

#### *Displacements*

When abnormal uterine bleeding occurs in association with fixed retroversion, its cause is not so much the displacement as the underlying disease, such as pelvic infection or endometriosis. Mobile displacements do not ordinarily disturb the menstrual cycle but they can do so if they lead to interference in venous return, and therefore to chronic congestion of the ovaries and the uterus. This is seen occasionally in *puerperal* retrodisplacement, ovarian prolapse and uterovaginal prolapse (*see* Chapters 16 and 17).

#### *Endometriosis*

When the ovaries are involved in endometriosis, polymenorrhoea or polymenorrhagia is likely; adenomyosis of the uterus, on the other hand, causes menorrhagia.

## Tumours

### *Ovarian*

*Follicular cysts* (Refer Chapter 33).

### *Neoplasms*

New growths of the ovary, even if bilateral, do not usually affect the menstrual function in any way. The exceptions to this rule are as follows:

- Oestrogen-producing tumours cause acyclical anovular bleeding.
- A large tumour, or one which undergoes axial rotation, disturbs the blood supply to the uterus and can cause one or more slight bleeding episodes.
- Non-functional ('misfit') tumours can mechanically stimulate the adjacent ovarian stroma to produce hormones – these are sometimes enough to cause slight postmenopausal bleeding but they rarely disturb the cycles of younger women.

## Uterine

Leiomyomas cause gradually progressive menorrhagia, the loss being heaviest on the second and third days as a rule. Polymenorrhoea is only seen when the tumour mass determines an increased blood supply to the ovary. Submucous myomas cause metrorrhagia when they become polypoidal and ulcerated. Rare tumours causing either menorrhagia or metrorrhagia include the haemangioma (Figs 38.2A and B). Malignant tumours usually present as postmenopausal bleeding.

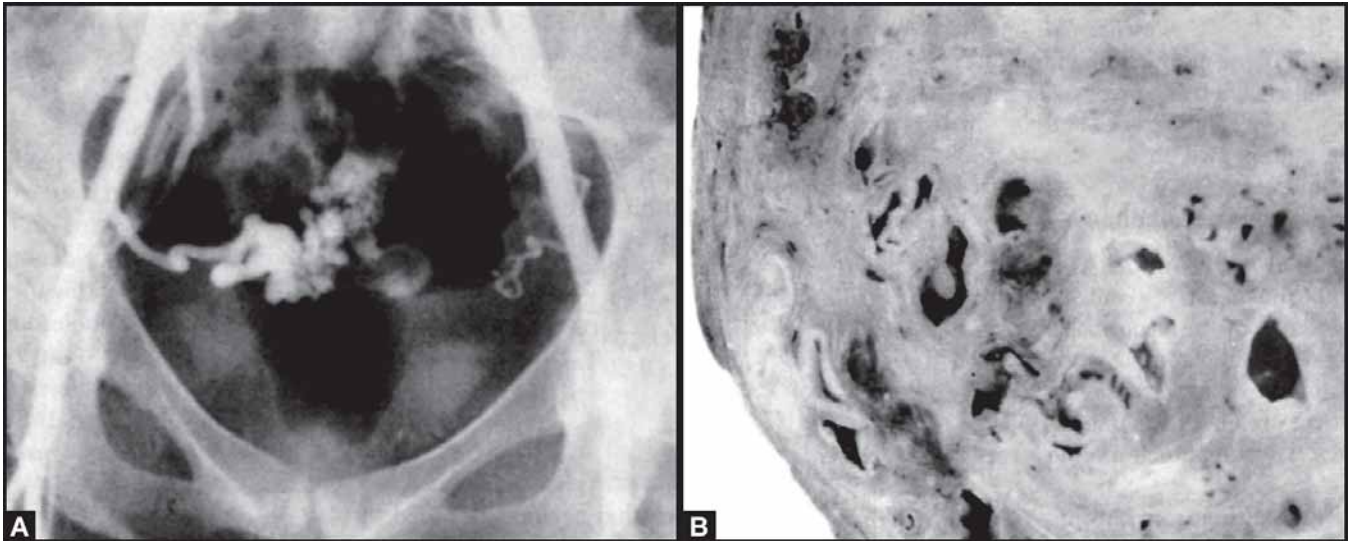
### *Surface Growths*

Endometrial polyps, and all malignant growths encroaching on the uterine cavity, cause irregular or continuous bleeding when they become ulcerated.

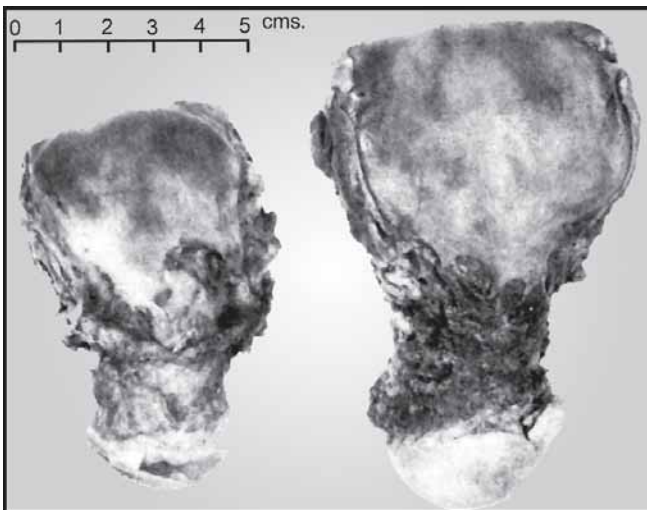
### *Chronic Symmetrical Enlargement of the Uterus*

Excessive uterine bleeding is sometimes associated with generalised enlargement of the uterus, both the myometrium and the endometrium being involved. This uncommon syndrome is seen at any age and irrespective of parity. The pathology is obscure and probably varies from case to case (Fig. 38.3). It can be the result of any of three conditions.

- *Idiopathic developmental hypertrophy*, such as is seen in other organs like the breast, the cause of which is



**Figs 38.2A and B:** A cavernous angioma of the uterus, with arteriovenous communications causing severe menorrhagia and metrorrhagia. The patient concerned was aged 32 years and her only pregnancy occurred 8 years earlier and resulted in hydatidiform mole. After its evacuation the menstrual cycle was slow to return to normal and, within 1-2 years, she developed periodic very heavy uterine losses. Choriocarcinoma was suspected but the hCG level remained normal and repeated curettage as well as clinical examinations gave negative findings. On two or three occasions each year the flooding was so severe as to necessitate the patient's admission to hospital and large blood transfusions. Curettage and various other treatments failed to prevent the attacks and, although these threatened life, hysterectomy was refused. A haemorrhagic diathesis was excluded and analysis of the happenings led to the conclusion that there must be some lesion in the uterus even though hystero-grams showed no abnormality. A haemangioma seemed likely and this prompted angiography. (A) An angiogram showing the multiple large vascular spaces and abnormal vascular channels within the uterus. Following this and another near fatal haemorrhage the woman agreed to hysterectomy, being influenced by the knowledge that any future pregnancy was likely to be unsuccessful, (B) A section of the uterine wall showing it riddled with a cavernous angiomatous condition, amounting in some places almost to arteriovenous aneurysms. It remains uncertain whether the original mole or trauma from repeated curettage played any part in the development of this condition. At present vascular embolisation could help to conserve the uterus in such a case



**Fig. 38.3:** A uterus with generalised hypertrophy obtained from a Para 2, aged 40 years, intense and overanxious, and complaining of menorrhagia, compared with one of normal size removed from a parous woman of the same age

unknown. This causes ovular menorrhagia and is sometimes found in young adults.

- *Generalised myohyperplasia or hypertrophy* in response to an excessive or prolonged and unopposed oestrogen influence; dysfunctional uterine bleeding (*see below*).
- *Generalised hypertrophy* resulting from chronic active or passive congestion which may in turn be caused by:
  - a. Local disease in the pelvis and especially vascular adhesions to the uterus.
  - b. General factors such as a sedentary occupation, working in a hot atmosphere or psychological disturbances (Fig. 38.3).
  - c. A varicocele of the pampiniform plexus in the broad ligament, but this is probably the result and not the cause of the congestion.

In these conditions the bleeding takes the form of menorrhagia, or polymenorrhagia if the ovaries share in pelvic congestion, and is ovulatory in type.

### Deep Venous Thrombosis

A rare but very real cause of menorrhagia is previous deep venous thrombosis which leaves the iliac and femoral veins blocked. Under such circumstances a collateral circulation is sometimes established through the uterus to the veins on the opposite side of the pelvis and this can be demonstrated by venography (Fig. 38.4). The resulting increased vascularity of the uterus can cause troublesome cyclical bleeding. The temptation to relieve this by hysterectomy should be resisted if possible because, if the collateral circulation is removed, the circulation in the leg of the affected side may worsen.

### Psychological Upsets

Emotional and nervous disorders may cause excessive uterine bleeding rather than amenorrhoea. Changes in environment, nervous tension, anxiety states, unsatisfied

sex urge, marital upsets, stress situations, and redundancy or over-work are examples of the factors which are commonly to blame. They are easily overlooked, especially as the abnormal menstrual pattern can be a delayed response and appear long after the crisis has passed. These factors operate possibly through the endocrine system which is influenced by the hypothalamus, but more probably through the autonomic nervous system which controls the blood vessels supplying the pelvic organs.

Active or passive congestion causes hypertrophy of the myometrium and endometrium so that the uterus can enlarge from two to six times the normal in size. A similar vascular upset which involves the ovaries may make them cystic, and causes polymenorrhoea.

Psychological factors are the commonest reasons for patients perceiving bleeding as excessive or abnormal. They also operate in the case of pubertal and post-menopausal bleeding (*see below*).

### Menorrhagia

Excess uterine bleeding either in quantity or duration is Menorrhagia.

Causes of Menorrhagia could be:

- a. Causes in the uterus:
  - i. Fibroid of uterus
  - ii. Adenomyosis
- b. Causes in the adenexa:
  - i. Endometriosis
  - ii. Pelvic inflammatory disease
- c. Causes in the higher centres
  - i. Dysfunctional Uterine bleeding (DUB)
  - ii. Hypothyroidism
- d. Miscellaneous causes:
  - i. Bleeding disorders
  - ii. Intra uterine device

However intermenstrual bleeding should arise the suspicion of neoplasms which could be benign or malignant

### Dysfunctional Uterine Bleeding

This term has been used to cover all forms of abnormal bleeding for which an organic cause cannot be found. The diagnosis can only be made by excluding all other causes for bleeding; this means that the frequency of the diagnosis depends on the definition of organic lesion, and on the care and trouble taken to exclude such a lesion.



**Fig 38.4:** Intractable menorrhagia resulting from occlusion of the left external iliac vein and the establishment of a collateral venous circulation from the affected side to the opposite by way of the uterus itself. The venogram shows no sign of the external iliac vein on the left side. The medium passes through the pelvic veins to the uterus, where it is pooled in the wall, and thence to the right internal iliac vein to reach the inferior vena cava. This is a well accepted phenomenon and in this case the deep venous thrombosis followed caesarean section. The left iliac vein remained occluded despite thrombectomy carried out at the time of the thrombosis. The patient in this case, a fifth para aged 33 years, was treated by hysterectomy. This controlled the menorrhagia but resulted in further chronic swelling of the left leg; it was also complicated by postoperative deep venous thrombosis

Dysfunctional bleeding occurs most commonly at the extremes of reproductive age (20% of cases occur in adolescence and 40% in patients over age 40). Management depends on the age of the patient (adolescent, young woman, or premenopausal woman).

Dysfunctional uterine bleeding (DUB) can be classified according to whether it is ovulatory or anovulatory.

### Ovulatory Bleeding

#### *Polymenorrhoea and Polymenorrhagia*

Here the ovary goes through its normal cycle but does so more quickly, the acceleration affecting the follicular rather than the luteal phase. Sometimes more than one follicle ripens at a time and there may be small follicular cysts present as well. The endometrium also goes through the usual phases but its proliferation increases and menstruation takes place every 2 or 3 weeks.

Polymenorrhoea is also occasionally seen during the few years following the menarche or preceding the menopause. The condition practically always cures itself in the course of a few months, or at the most 1 or 2 years. In the case illustrated in Figure 38.1, a clear cause — a pituitary tumour was found to account for the excessive ovarian activity, but this is exceptional. Polymenorrhoea, persisting for a few months, sometimes occurs after pregnancy and is presumably due to a failure of the pituitary, whose function is disturbed during pregnancy, to return to normal in good time. The ovary is therefore stimulated excessively or abnormally.

A similar alteration in rhythm occurs when pelvic infection causes chronic congestion of the ovaries. When polymenorrhoea dates from pregnancy it is therefore important to exclude chronic salpingo-oophoritis.

In fact, the majority of cases of polymenorrhoea and polymenorrhagia, and therefore of dysfunctional bleeding, occur among women aged 30-40 years, and the symptoms are related to childbearing rather than a particular pregnancy and delivery. The subjects are usually overwhelmed by the care of their children and their home; they have little help, few holidays, and may be attempting additional work. These women also tend to suffer from the premenstrual syndrome, irritable bowel syndrome and other manifestations of a background of stress. It appears that the stress-induced situations are due to either a higher cortical effect on the hypothalamic releasing factors, or the effect of neurohormonal substances from the central nervous system directly on the uterine vasculature.

Heavy or prolonged menstrual losses at normal intervals can be the result of corpus luteum defects which present in the following ways:

- *Irregular ripening of the endometrium* due to poor formation and function of the corpus luteum. The endometrium is without adequate hormonal support so slight losses or spotting occur for many days before the proper flow starts. The only other causes for regular premenstrual spotting are cervical erosion and cervical polyp. The condition is analogous to the 'breakthrough' bleeding which often attends the administration of oestrogen-progestogen preparations. It is diagnosed by finding only patchy progesterational changes in endometrium removed during menstruation, but, in this respect, artefacts are common and can be deceptive. More reliable evidence is the *repeated* finding of low serum progesterone levels, during the second half of the cycle.

As a regular occurrence, faulty corpus luteum function is probably rare but a *single* episode of this type of bleeding is very common. The patient, having previously had a regular cycle, complains that she started to bleed again a few days after the cessation of a period. This bleeding continues intermittently until the next period and thereafter all symptoms disappear. Presumably the follicle is faulty in some way in these cases and once its activity ceases and that of a new one commences, the symptoms disappear. It follows that in such a case it is best to wait one month before giving any treatment.

- *Irregular shedding of the endometrium* due to incomplete and slow degeneration of the corpus luteum (Halban's disease). Here slight bleeding continues intermittently for several days after the proper flow and patchy progesterational appearances persist in an endometrium which should be in the early proliferative phase.

Again, histological artefacts may be deceptive and this type of abnormal bleeding is probably rare.

### Anovulatory Bleeding

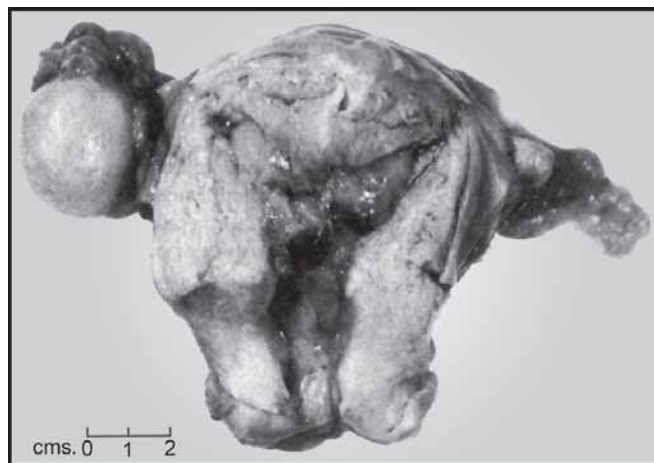
Anovulation or oligo-ovulation is the commonest cause of abnormal uterine bleeding when no organic cause has been found.

The characteristic feature is the absence of active corpus luteum tissue in the ovary. A follicle ripens but fails to rupture; the ovum dies and the follicle may go

on to cyst formation. Whether it forms a cyst or not, it produces oestrogen for a time and this acts on the uterus without being opposed by progesterone. The production may be continuous at a moderate level, or intermittently high and low. In either case the uterus responds by hypertrophy of its myometrium and endometrium, and the latter may become polypoidal (Fig. 38.5). On section, the endometrium shows the picture of hyperplasia, usually of the cystic type ('Swiss cheese') but occasionally adenomatous.

Bleeding is acyclical. It is continuous for 2-8 weeks and can be so heavy as to threaten life. In about half the cases it is preceded by a short period of amenorrhoea which coincides with a continuously high production of oestrogen by the follicle and this type of clinical picture was earlier often labelled as metropathia haemorrhagica. When the granulosa cells become less active, or when the endometrium grows so thick that the supply of oestrogen becomes relatively inadequate, oestrogen withdrawal bleeding takes place. *The bleeding is always painless* and this helps to distinguish the condition from abortion or ectopic pregnancy, both of which give rise to a rather similar menstrual disturbance. On examination, the uterus feels slightly enlarged and it is sometimes possible to palpate the cystic ovary. A definitive diagnosis can only be made by histological examination of curettings.

The underlying cause is unknown. Presumably the failure in ovulation reflects an abnormal gonadotrophin



**Fig. 38.5:** A specimen illustrating the pathology of anovulatory DUB (metropathia haemorrhagica). The left ovary contains a follicular cyst and this has caused hypertrophy of the myometrium and polypoid hyperplasia of the endometrium

stimulus. Behind this there is often a hypothalamic and cortical basis, as in the case of other forms of dysfunctional bleeding, being mostly seen in nervously tense and emotional subjects. It occurs most commonly during the few years preceding the menopause, but is occasionally seen in girls aged 12-20 years. In the latter it shows a strong tendency to spontaneous cure.

## DIAGNOSIS

Before diagnosing abnormal uterine bleeding, it is first necessary to ensure that the bleeding is coming from the uterus and not from the cervix and lower genital tract. Haemorrhage via the anus or urethra, which patients often confuse with a vaginal efflux, also has to be excluded. The symptom may be alleged and not genuine; several cases are recorded in which women stained their clothing and bed linen with coloured fluids, even with bottled blood from a transfusion store, to substantiate their story of menorrhagia.

Again, women vary in their criteria for abnormal bleeding. Thus one who says she has been having severe menorrhagia for 3 years, but whose haemoglobin level is over 12 g/dl, is suspect. Moreover, the complaint must be measured against the standard cycle for that particular patient. The number and thickness of sanitary pads required is a useful measure of the menstrual loss; a proprietary intravaginal tampon is never enough to contain bleeding which is abnormally heavy. The passage of clots, significant in size and number, indicates that the loss is so heavy as to defeat the normal fibrinolytic activity of the uterus.

When there is doubt about the severity of occurrence of the bleeding, the patient should be examined when it is present.

Satisfactory treatment is dependent on determining the cause and type of bleeding. Once it is established that a woman suffers from significantly abnormal uterine bleeding, the approach to the case is governed by the following principles:

- Below the age of 20 years the disturbance is most likely to be a functional one with a tendency to spontaneous cure.
- In active reproductive life an organic cause for bleeding is more likely, some pregnancy-related condition being the most common.
- After the age of 40 years, functional disorders are common but the possibility of a growth, benign or malignant, must first be excluded.

- After the menopause, a local organic cause (the most important being cancer) is often present and, even if none is found, the possibility should not be dismissed.

### Clinical Examination

Attention is paid to the time and mode of onset of the bleeding, and to its relationship to puberty, to pregnancy and to the last normal period. Exact details of the amount, duration, and frequency of bleeding must be ascertained. When the cause is obscure, and when there is clearly no urgency, the patient can be given a chart on which to keep a record of all losses during 3 or 4 months. A menstrual calendar can be most revealing and often allows a conclusion that there is nothing fundamentally wrong. Moreover, it has the advantage that it necessitates withholding treatment for a time and it will frequently be found that a minor disturbance undergoes spontaneous cure during the period of observation.

The patient's background and environment, and the presence of emotional upsets and marital problems, deserve detailed study. A history of a bleeding tendency, epistaxis, bruising or similar symptoms, gives a clear guide to blood disorders.

Physical examination must cover all systems, not merely the genital tract. With regard to the latter, the thoroughness with which it is examined depends on the circumstances of the case and particularly on the age and status of the patient.

### Haematological and Endocrine Evaluation

It is always essential to determine the haemoglobin level and, in selected cases, a full examination of the blood (including platelet count, assessment of the bleeding and coagulation times or even a full coagulation profile) is indicated. This is particularly important when symptoms persist for no apparent reason — especially if the patient is young and if there is a history of haemorrhage from sites other than the uterus.

Evaluation of the kidney, liver, and thyroid functions is done when indicated. Thyroid function should be especially evaluated in cases of menorrhagia. Serum prolactin, follicle stimulating hormone (FSH) and luteinising hormone (LH) are assayed if hyperprolactinaemia or polycystic ovary syndrome (PCOS) is suspected to be the cause of anovulation.

### Ultrasound

Ultrasound examination is an adjunct if pelvic examination is unreliable, as in the case of the obese woman or the retroverted uterus. The vaginal transducer is especially helpful in excluding organic pelvic lesions — enlarged uterus, leiomyomas, adenomyosis, complications of pregnancy, ovarian cysts, endometriosis, etc. Even in those cases where pelvic examination is satisfactory, the greatest advantage of the transvaginal scan is that the endometrial thickness can be measured. A very thick endometrium may in fact be an endometrial polyp. Saline infusion sonography may be done to delineate an endometrial polyp or a submucous myoma.

### Hysteroscopy

Hysteroscopy should ideally be done in all cases where a transvaginal ultrasound reveals a thickened endometrium. It can reveal a previously suspected or unsuspected intrauterine lesion, e.g. endometrial hyperplasia, carcinoma, polyp or myoma and allows suspicious lesions to be biopsied. In this respect it has an advantage over blind endometrial sampling and the two procedures can often be combined where the facilities are available, the diagnostic hysteroscopy being followed by guided biopsy or endometrial aspiration. Hysteroscopy also enables the diagnosis of atrophic endometrium. Hysteroscopic polypectomy is a simple procedure which can avert a hysterectomy in a young woman. In some instances it will be performed in conjunction with laparoscopy. Hysteroscopic myomectomy can be done for submucous leiomyomas.

### Hysterosalpingography (HSG) and Sonosalpingogram (SSG)

HSGs has not much of place as there are facilities like hysteroscopy or saline sonography also called as sonosalpingogram to identify any intrauterine pathology. SSG is simple technique where in saline is instilled into the uterus and a vaginal sonography is done. If there are any intrauterine pathology the same may be later confirmed by doing a hysteroscopy.

### Endometrial Sampling

The main objectives of this procedure are to exclude a local intrauterine lesion such as incomplete abortion,



uterine polyp, tuberculous endometritis and carcinoma as a cause of bleeding, and to obtain endometrium for study of its hormone responses. Any therapeutic effect the operation may have is incidental. *The more irregular the bleeding, the greater the indication for endometrial sampling.* This can usually be carried out as an 'office' procedure without anaesthesia. When a polyp is suspected, hysteroscopy should be done (*see below*). Dilatation and curettage is almost never needed.

Failure to do an endometrial aspiration in an older woman can result in delay in the diagnosis of malignant disease, but there is little doubt that a very large number of these procedures carried out on younger women are unnecessary from the standpoint of either diagnosis or treatment. It is pointless, for example, when the complaint is polymenorrhoea. Endometrial sampling is not a procedure to be carried out empirically and for want of something better to do; it should be planned with a clear objective in each case. Moreover, it is to be recognised that, even in the hands of the most experienced gynaecologists, it may fail to reveal an early carcinoma or a polyp. In young girls, it is not usually done unless medical management fails or ultrasound suggests the possibility of an organic lesion.

The endometrium should be examined histologically in all cases, the picture being interpreted in relation to the day in the menstrual cycle on which the specimen is obtained. It is wise to have some of the endometrium cultured for acid fast bacilli (AFB) and also submitted for polymerase chain reaction (PCR), if possible, whenever there is a clinical suspicion of tuberculosis.

### Magnetic Resonance Imaging

MRI gives very accurate pictures of the uterus and the endometrium. It can identify endometrial lesions, e.g. polyps, as well as myometrial invasion by endometrial cancer. However, it is expensive and not used routinely.

### Angiography and Venography; Colour Doppler

These are only indicated when a history of deep venous thrombosis in one leg or a suspicion of uterine haemangioma raises the possibility of gross abnormality in the vascular apparatus of the uterus. They can then be diagnostic (Figs 38.2 and 38.4) and embolotherapy can be carried out at the same time. Colour doppler imaging can provide similar information.

## TREATMENT

When an organic cause for bleeding is found, its nature determines subsequent treatment. This section is concerned only with the treatment of abnormal uterine bleeding of more obscure origin, and this is governed by two overriding principles. First, in youthful patients it is usually safe and wise to procrastinate, whereas in women past the age of 40 years treatment should be both prompt and radical. Secondly, where no organic cause is found, treatment aims at controlling symptoms, the cure being nearly always spontaneous.

### General

When heavy bleeding is in progress the patient should rest, in bed if necessary, and sedatives may be given to allay anxiety if required. Between bleeding episodes, normal activities are encouraged to prevent pelvic congestion. Dietetic errors and any cause for emotional upset should, if possible, be corrected. The harassed middle-aged mother should reorganise her life, and break the physical and nervous tension by sleeping for 1-2 hours in the middle of each day. Anaemia, no matter whether it be the cause or effect, is treated according to its type and degree.

### Medical Management

#### Non-hormonal Methods

*Prostaglandin synthetase inhibitors:* There is evidence that prostaglandin E compounds are increased in menorrhagia, although the mechanism is unclear. Mefenamic acid, 250-500 mg three times daily, is effective in reducing menstrual loss by 20-50 per cent in 75 per cent of patients, although it has little effect on cycle length. There are few side-effects and, as administration is restricted to the time of the blood loss, it is often preferred to oestrogen-progestogen preparations by the patients. It may well be the first choice for those over the age of 35 years. Diclofenac, ibuprofen and naproxen are also useful.

*Antifibrinolytic Agents:* For menorrhagia (and for bleeding caused by an intrauterine contraceptive device), symptomatic treatment can be given with antifibrinolytic agents administered orally for 3-6 days during each period. These include e-aminocaproic acid (EACA) 3 g, 4-6 times daily, or tranexamic acid, 1 g, 2-4 times daily.

They can reduce menstrual loss by about 50 per cent during therapy. This may be tried when oestrogens and progestogens are contraindicated or unsatisfactory, although a history of thromboembolism is a contra-indication for their use.

## Hormones

Hormone therapy has an important place in the treatment of women of reproductive age but is rarely indicated after the age of 40 years. *The younger the patient, the better the result*; this is because the ultimate cure is spontaneous.

### Oestrogens

If the bleeding is very heavy (whether ovulatory or anovulatory) or is anovulatory and unresponsive to progestogens, parenteral conjugated equine oestrogens (CEE) can be administered in a dose of 12.5 mg i.v. to stop the bleeding and repeated after 12 hours if necessary. Subsequent therapy can be started with combined oral contraceptives or progestins (*see below*). Alternatively, a GnRH analogue can be used along with parenteral CEE and this produces a prolonged period of amenorrhoea.

### Oestrogens and Progestogens

Combined oral contraceptives can be used in ovulatory DUB. Sequential oestrogen and progestogen can be used instead. The endometrium is thus taken through its full cycle and should shed normally 2-10 days after the course is completed. Blood loss is decreased by 50 per cent.

For moderately severe bleeding, treatment can be initiated with up to 3-4 tablets per day and then gradually decreased to 1 tablet daily once the bleeding stops. This dose is then continued for 3 weeks.

### Progestogens

For the anovulatory type of dysfunctional bleeding in girls and young women, it is preferable to give progesterone by injection or one of the synthetic progestogens orally. The aim is to convert the hyperplastic endometrium into a secretory phase and then to precipitate normal shedding when treatment is discontinued. This procedure has been called *medical curettage*.

If therapy is commenced during an episode of heavy bleeding, 10-30 mg of the chosen progestogen, usually

norethisterone acetate, is given daily until the bleeding ceases, which it usually does within 3-7 days, as this has better haemostatic action. Once the treatment is suspended, withdrawal bleeding starts after 2 or 3 days and the patient must be warned to expect this; *it stops of its own accord* like a normal period. Thereafter, it is usual to await events and sometimes it will be found that the patient remains amenorrhoeic for 6-8 weeks. If heavy and prolonged bleeding recurs, another course of treatment is given to control it. In adolescents, only 2 or 3 courses may be required before a normal cycle is spontaneously established.

To avoid relapses, progestogens may be administered cyclically for a few months after the initial attack is controlled; one of the synthetic progestogens, such as dydrogesterone or medroxyprogesterone acetate 10 mg daily from the sixteenth to twenty-fifth day of the cycle is used in women with luteal phase deficiency. However, in women with endometrial hyperplasia, it is usually necessary to administer progestogens for 21 days, starting from the first or the fifth day of the cycle. Cyclical therapy is given for a minimum of 3, and usually for 6 to 9 cycles. Clinical assessment of response is possible but endometrial aspiration to confirm reversal of histological changes is mandatory at the end of this period.

There are some who prefer to administer the progestogen continuously till the hyperplasia is reversed (usually 3 cycles) and then continue cyclical therapy for another 3-6 cycles. Progesterone therapy is reported to decrease the blood loss by 80 per cent. Progesterone and levonorgestrel IUCDs have been used in the treatment of anovulatory DUB and have the advantage of avoiding daily administration and systemic side-effects. Blood loss is decreased by 90 per cent. The progestin IUCDs have been found to be useful in ovulatory bleeding as well.

## Treatment

### Adolescents

Because the first menstrual cycles are frequently anovulatory, it is not unusual for menses to be irregular, and explanation of the reason is all that is necessary for treatment. Heavy bleeding—even haemorrhage—may occur. Diagnostic procedures are usually not necessary in young patients, progestogens or oestrogens or a combination of both given orally should be adequate for all patients except those requiring curettage to control haemorrhage which is extremely rare. Numerous

regimens are available, including oestrogens followed by progesterone, progesterone alone, or combination oral contraceptives. For acute haemorrhage if the endometrium is thick progestogens are given starting with high doses of Norethisterone acetate 10 mg three times per day tapered down after about five days when the bleeding reduces. When the endometrium is thin there is role for high-dose oestrogen given intravenously (25 mg conjugated oestrogen every 4 hours) gives rapid response. In haemodynamically stable patients, the oral dose of conjugated oestrogens is 2.5 mg every 4–6 hours for 14–21 days. Once bleeding has stopped, medroxyprogesterone acetate 10 mg once or twice a day should be given for 7–10 days.

Oral contraceptives, 3–4 times the usual dose, are just as effective and may be simpler to use than sequential hormones. Again, the dose is lowered after a few days and the lower dose is continued for the next few cycles, particularly to raise the haemoglobin levels in an anaemic patient. Medroxyprogesterone acetate, 10 mg/day for 10 days, can be used in patients who have proliferative endometrium on biopsy. In patients receiving cyclic therapy, 3–6 monthly courses are usually administered, after which treatment is discontinued and further evaluation is performed if necessary. In adolescents in whom the bleeding is not severe, oral contraceptives may be used as normally prescribed.

#### *Young Women*

In patients 20–30 years old, pathologic causes are more common and diagnostic procedures are more often necessary, particularly endometrial biopsy or aspiration. Hormonal management is the same as for adolescents.

#### *Premenopausal Women*

In the later reproductive years, even more care must be given to excluding pathologic causes because of the possibility of endometrial cancer. Aspiration, curettage, or both should clearly establish anovulatory or dys-synchronous cycles as the cause before hormonal therapy is started. Recurrences of abnormal bleeding demand further evaluation.

#### *Surgical Measures*

For patients whose bleeding cannot be controlled with hormones, who are symptomatically anaemic, and whose lifestyle is compromised by persistence of

irregular bleeding, D&C may temporarily stop bleeding, but abdominal or vaginal hysterectomy may be necessary. Endometrial ablation techniques are useful in patients who have personal or medical contraindications to hysterectomy. Definitive surgery may also be needed for coexistent endometriosis, myoma, and disorders of pelvic relaxation.

#### *Androgens*

Androgens will usually control DUB of any type but are to be avoided because of their virilising effects. These are less likely in women over the age of 40 years, to whom 5–10 mg methyltestosterone daily can be given but for no longer than 2 months (Figs 38.6A and B). In an emergency, the dose can be increased but is then given only for a few days.

Mixed preparations of androgen and oestrogen, or androgen and progestogen, are also available for haemostatic purposes. They have so many disadvantages that they are best avoided.

*Danazol* in doses of 200–400 mg for 12 weeks reduces the blood loss by 50 per cent. The effect is relatively short lived and lasts for only 2–3 months after cessation of treatment. Despite its expense and side-effects it may have a place in the short-term management of a patient in whom oestrogen-progestogen and antifibrinolytics are contraindicated or not effective.

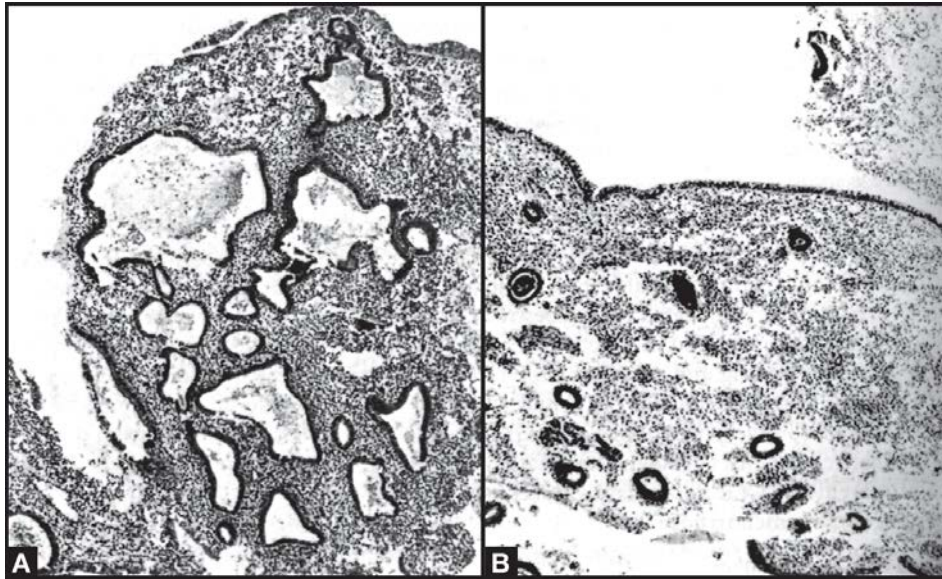
*Gestrinone* is a synthetic derivative of 19-nortestosterone with antioestrogenic, antiprogestational and some androgenic activity. It is administered in a dose of 2.5 mg dose twice weekly for 12 weeks.

#### *GnRH Analogues*

GnRH agonists have been used mainly for bleeding associated with leiomyomas but can be used for DUB as well. Fifty per cent of women with anovulatory DUB and endometrial hyperplasia show a response but adjuvant therapy for osteopenia is required if therapy is to be continued for more than 6 months. Danazol, gestrinone and GnRH agonists are generally used as second-line therapy.

#### **Surgery**

The place of surgery in the treatment of excessive bleeding without an organic basis varies with the age of the patient; it should be a last resort in young girls but



**Figs 38.6A and B:** Endometrial hyperplasia reversed with testosterone, (A) A section of the curettings of a nulliparous woman, aged 32 years, with intractable metropathia haemorrhagica. (B) A section of endometrium obtained from the same patient after 2 months' treatment with methyltestosterone by mouth, and showing gross atrophic changes. The magnification is the same for both (A) and (B)

may be considered earlier in women above the age of 40 years. Nevertheless, in the latter group it is good practice to exclude organic disease by ultrasound and endometrial aspiration, to try medical therapy and proceed to hysterectomy if the response is inadequate or not sustained. In girls and young women a conservative outlook is justified by the likelihood of a spontaneous cure, by the need to preserve reproductive function, and by the desirability of not focusing the patient's attention on her genital tract. In older women the need for conservative treatment is no longer pressing and there is a real possibility of an organic cause for the bleeding.

### Curettage

Although this operation is primarily diagnostic, it sometimes appears to be curative especially in cases of irregular shedding. *Curettage is of no value in the treatment of polymenorrhoea.*

### Endometrial Ablation

Transcervical resection of the endometrium (TCRE) is an attractive alternative to hysterectomy in the younger woman who has no desire for future fertility but wishes to preserve her uterus, and in the older woman with

obesity or medical contraindications for hysterectomy. It is not suitable for women with an excessively enlarged uterus (length >12 cm on sounding) or with intrauterine pathology or infection.

Pretreatment with danazol or GnRH agonists is given for 6 weeks to decrease operative blood loss. The entire endometrium is ablated by electrocautery using a resectoscope, roller ball or a combination of the two, starting with the fundus and proceeding successively to the anterior, lateral and posterior walls but avoiding the cervix. Routine laparoscopic control is not required. Success rates of nearly 90 per cent are obtained, with about 60 per cent of patients reporting amenorrhoea.

The procedure is simple; hospital stay and time to recovery are considerably reduced. Complications include fluid overload leading to pulmonary oedema; uterine perforation and cervical trauma; bleeding; anaesthetic complications; electrical/laser injury; infection and air embolism. About 1.3 per cent of patients require emergency hysterectomy because of perforation or injury to the large vessels; about 5-10 per cent need hysterectomy later because of failure of therapy. Thermal injury to the cervix can lead to stenosis, dysmenorrhoea and retention of secretions. Hysteroscopic laser photovaporisation with the Nd:YAG laser has been found to have similar results.

### Global Endometrial Ablation Techniques

TCRE is not universally practised in spite of its proven efficacy and safety. Several simpler procedures are being developed for the blind ablation of the endometrium. Fluid-filled thermal balloons are placed in the uterus. These use hot water or saline delivered by disposable balloon catheters under sophisticated computer control to regulate temperature, pressure and depth of thermal damage. Satisfactory results have been obtained with minimal side-effects and the procedure is easy to learn, but presently the equipment is expensive.

Other techniques which have been tried include radio frequency thermal balloon, three-dimensional bipolar ablation, microwave endometrial ablation, laser interstitial hyperthermy using an Nd:YAG laser, and cryoablation. These methods are still under trial and long-term results are awaited.

### Hysterectomy

When the patient is above 40 years of age, and when the haemorrhage fails to respond to simpler measures, hysterectomy is indicated. It is the treatment of choice in all cases of persistent or recurrent postmenopausal bleeding for which there is no obvious cause. Hysterectomy can usually be carried out easily by the vaginal route and this involves little risk.

In younger women, this is to be avoided whenever possible. Even in these, there comes a time when hysterectomy with conservation of the ovaries is preferable to incapacity prolonged indefinitely merely for the sake of preserving what is likely to be a very unsatisfactory reproductive function.

A detailed preoperative work-up including hysteroscopy is essential in all young women, to be sure that this operation is warranted. The exact procedure depends on the patient and the surgeon — vaginal, abdominal or laparoscopy-assisted vaginal hysterectomy (LAVH) have all been used, but the last is not usually required unless there are adhesions or some other pelvic lesion.

### Radiotherapy

In the rare situation when medical therapy is unsuccessful and hysterectomy is contraindicated for any reason, intractable DUB can be arrested and the menopause induced by means of megavoltage

irradiation. Radiotherapists and gynaecologists prefer external irradiation, arguing that it is not followed by uterine injury or disease (including cancer). In all cases, a complete work-up including endometrial sampling should be carried out before external radiation is used. Patients should be warned that they may have one, or possibly two, periods before external therapy is effective.

### Advantages

- The treatment is practically devoid of immediate risk.
- In women aged more than 40 years, adequate dosage induces permanent amenorrhoea in 95-99 per cent of cases, depending on how thoroughly an organic cause for bleeding is excluded.

### Disadvantages

- An operation is not entirely avoided, even when X-rays are used, because preliminary endometrial aspiration is essential to exclude malignant disease.
- Both methods cause temporary systemic upsets.
- Menopausal symptoms are common sequelae.
- The use of intracavitary radium, at least, leaves behind a damaged organ in which may develop haematometra, pyometra and even carcinoma. The incidence of uterine cancer after a radiation menopause ranges from 0.3 to 1.4 per cent, depending on the material investigated. In a large number of cases recorded, the cancer was present but was overlooked at the time of treatment. Excluding these, however, the risk of carcinoma of the body or cervix of the uterus may be higher because the woman who has premenopausal bleeding of such severity as to justify radiotherapy possibly has a special predisposition to neoplasia.
- It does not allow the definite exclusion of an organic basis for the bleeding.
- In women aged less than 40 years the sterilisation is often not permanent and they may conceive even before they menstruate again. There is then a theoretical risk of a damaged ovum transmitting abnormal genes, and established risks of abortion and of cervical dystocia in labour.

In view of these considerations, hysterectomy is generally preferable to the radiation menopause, but in a few women with severe medical problems it can sometimes be life-saving.

## SPECIAL CLINICAL TYPES OF BLEEDING

### Ovulation Bleeding

Ovulation bleeding is not strictly abnormal; it is a common, if not regular, cyclical phenomenon in all women. However, both patient and attendant may fail to distinguish it from menstruation and thus mistake what is an essentially normal cycle for polymenorrhoea.

### Clinical Features

Some individuals appear more susceptible to overt ovulation bleeding than others but even in these its occurrence is inconstant. It may be present in some months and not in others, and can disappear for years. The bleeding usually lasts only a few hours and rarely for longer than 2 or 3 days. It is small in amount, often consisting of nothing more than 'spotting' or of a red tinge in the mucoid ovulatory discharge from the cervix. It is said that all women experience this phenomenon and that most are not aware of it because the loss is literally microscopic. Ovulation bleeding may, or may not, be accompanied by ovulation pain. Its diagnosis rests on the time and character of the loss.

### Cause

The bleeding usually occurs from the endometrium and is probably the result of a temporary oestrogen deprivation during the change-over from the follicular to the luteal phase in the ovary. Normally there is a fall in the blood oestrogen level at this time. Ovulation bleeding is said to be more likely when the pelvic organs are congested. Another view is that the bloodstained discharge originates from the ovary at the time of ovulation, and is picked up by the tubes to be passed through the uterus.

### Treatment

Ovulation bleeding is a physiological phenomenon which does not ordinarily require any treatment other than explanation.

### Prepubertal Bleeding

Prepubertal bleeding is arbitrarily defined as bleeding before the age of 10 years (some say 8 or 9 years).

### Precocious Puberty

The bleeding may be menstrual and due to precocious puberty; it is then accompanied by other evidence of sexual maturation.

### Non-menstrual Bleeding

Vaginal bleeding in childhood without concomitant development of secondary sex characters always calls for careful investigation because it is probably not menstrual in type. The causes include foreign bodies in the vagina, vaginitis, and neoplasms of the vagina, cervix and uterus.

### Genital Crisis in the Newborn

Slight uterine bleeding, sometimes amounting to no more than a single bloodstained smear on a napkin, occurs in 10 per cent of female babies 2 or 3 days after birth. This is an oestrogen withdrawal phenomenon, the foetal uterus having been stimulated before birth by placental oestrogen. No treatment is necessary; the discharge ceases in a few hours or days.

### Pubertal Bleeding

This is arbitrarily defined as excessive bleeding occurring between the menarche and the age of 20 years. The first one or two periods are commonly profuse, prolonged and irregular in time of onset but such disturbance generally cures itself quickly and medical advice is usually not sought. Sometimes, however, the bleeding is so heavy as to produce anaemia and even to threaten life ('near-fatal menarche'). There may be several such episodes during the 2 or 3 years before a regular cycle is established, and any can call for blood transfusion. Extreme, alarming and persistent forms of pubertal bleeding are mostly seen in spoilt, often only children with overanxious parents. Sometimes a normal loss may be claimed to be excessive.

Pubertal bleeding is usually anovulatory in type. Polymenorrhoea, probably ovulatory in type, is also seen. The treatment of these conditions is described above.

### Perimenopausal Bleeding

Perimenopausal bleeding is the excessive bleeding which commonly occurs at the age when the menopause might be expected.

The menopause is *never* normally heralded by increasing menstrual loss and the only safe rule is to regard any bleeding which is heavier in amount, longer in duration, or acyclical, occurring in a woman more than 40 years of age, as requiring immediate and careful investigation. Essentially, this means pelvic examination, cervical and endometrial cytology, cervical biopsy and curettage, with the possibility of malignant disease ever in mind. In fact, cancer of the uterus is found in less than 5 per cent of women complaining of *premenopausal* bleeding.

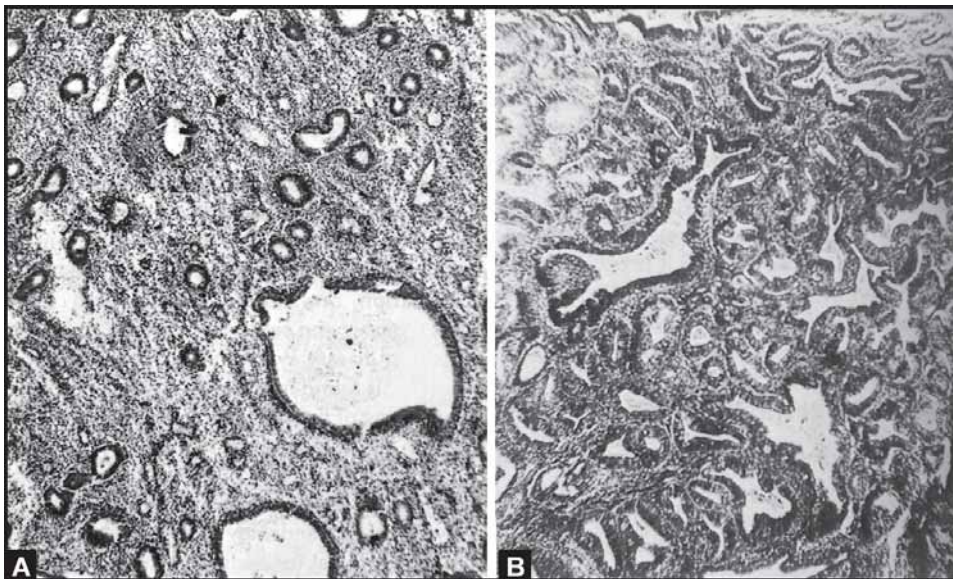
Often shortening of the menstrual cycle because of a shortened follicular phase is the first change of menopause. In some cases the bleeding proves to be dysfunctional and anovulatory in type, but often no endometrial abnormality is found. For a full list of possible causes *see* postmenopausal bleeding (*see below*).

One basis for excessive and prolonged bleeding around the time of the menopause is the injudicious use of oestrogens. These are prescribed for real or imagined climacteric symptoms, arthritis, emotional instability, pruritus vulvae and the like; they operate no matter whether they are given by injection, orally, or in the form of ointments and gels. Moreover, an admixture of an androgen does not always prevent them stimulating the endometrium. In a susceptible woman, one tube of an oestrogen ointment applied to the vulva may be enough

to cause uterine bleeding. Careful inquiry about the use of any remedies, bearing in mind that proprietary preparations containing oestrogen can be obtained by the public without a medical prescription, is essential in all cases (Figs 38.7A and B). When abnormal uterine bleeding occurs in middle-aged women taking oestrogens, how should the case be managed? Ideally, endometrial aspiration should always be carried out to exclude malignant disease. Nevertheless, this is not always practicable and the compromise solution is to exclude a gross abnormality by vaginal examination, cytology and ultrasound, and to discontinue the oestrogen. All bleeding should then clear within one month; if it does not, or if it recurs after that time, hysteroscopy and endometrial sampling are essential.

### Postmenopausal Bleeding

Bleeding from the genital tract occurring after the menopause is much more sinister than premenopausal bleeding. In defining postmenopausal bleeding, the question arises as to when the menopause can be regarded as established. An arbitrary time limit of one year's amenorrhoea is generally set but some prefer to reduce the period to 6 months. Even without amenorrhoea or irregularity, menstruation continuing after the age of 55 years should be investigated.



**Figs 38.7A and B:** Oestrogen-induced postmenopausal bleeding, (A) Cystic hyperplasia of the endometrium in a postmenopausal woman suffering from uterine bleeding following oestrogen therapy for 'flushes'. (B) Atypical endometrial hyperplasia in a postmenopausal woman who had medicated herself with oestrogens for 2 years

## Causes

Postmenopausal bleeding is more likely to be caused by pathologic disease than is bleeding in younger women, and it must always be investigated. Nongynaecologic causes must be excluded; these are also more likely to be caused by pathologic disease in older women, and the patient may be unable to determine the site of bleeding. The source of bleeding should not be assumed to be nongynaecologic unless there is good evidence or proper evaluation has excluded gynaecologic causes.

Neither normal ("functional") bleeding nor dysfunctional bleeding should occur after menopause. Although pathologic disorders are more likely, other causes may also occur. Atrophic or proliferative endometrium is not unusual. Secretory patterns should not occur unless the patient has resumed ovulation or has received progesterone therapy.

After nongynaecologic causes of bleeding are excluded, gynaecologic causes must be considered.

The commonest cause for bleeding occurring after the menopause is the *indiscriminate use of oestrogens* for HRT. If this is excluded, 10 per cent of all patients, and 30-50 per cent of those in whom the bleeding is continuous or occurs more than once, are accounted for by malignant disease of the cervix or of the body of the uterus.

The possible causes of postmenopausal bleeding are listed *below*, and, except for the senile states, they apply equally to premenopausal bleeding.

- Oestrogen therapy
- Benign and malignant neoplasms of the vulva, vagina, cervix, corpus, fallopian tubes
- Ovarian tumours oestrogen-producing tumours any tumour of large size affecting the vascularity of the uterus 'Misfit tumours' (*see above*)
- Infections
  - Vaginitis — *Trichomonas*, *Candida*, *Chlamydia*, senile
  - Endometritis - tuberculous, senile pyometra and haematometra
- Dysfunctional uterine bleeding
  - Anovulatory
  - Ovulatory
- Injuries
  - Direct trauma
  - Decubital ulceration
  - Foreign bodies such as supporting pessaries
  - Postradiation ulceration

- Diseases of the blood and the capillaries
- Bleeding from the urethra, bladder and rectum (mistaken for vaginal bleeding)
  - Urethral caruncle
  - Papilloma and carcinoma of the bladder
  - Haemorrhoids and fissure-in-ano
  - Carcinoma of the rectum
- No cause found (? vascular or psychogenic basis)

In approximately 10 per cent of cases, the bleeding proves to be either 'dysfunctional' or caused by a reawakening of ovarian function. Thus anovulatory bleeding and endometrial hyperplasia without bleeding can occur 1 and 2 years after the menopause. In these cases continued production of steroid hormones by the hilus or stromal cells is postulated. An ovarian source is suggested by the fact that oophorectomy lowers the hormone levels. Indeed, the production of oestrogens by ovarian stromal cells for as long as 25 years after the menopause is reported. Nevertheless, whenever the endometrium is found to be hyperplastic, and the vulva and vagina look under the influence of oestrogens, two questions arise: (1) Is the hormone exogenous? (2) Is there a small granulosa or theca cell tumour in the ovary? Occasionally, postmenopausal bleeding is ovulatory and is then presumably the result of the belated ripening of a stray ovum — a phenomenon which has been called 'flash in the pan' menstruation. This is usually seen soon after menopause.

Postmenopausal hyperplasia carries a stronger threat of cancer than does premenopausal hyperplasia. It is also an indication for testing the blood sugar.

In patients who have had only *one* episode of slight postmenopausal bleeding, it is common (12-50 per cent of cases) not to find any abnormality. In these, as well as in women with dysfunctional bleeding, a sudden emotional shock or other upset may be in the background. The bleeding must result from a break in endometrial blood vessels and it appears more likely in hypertensive women.

Of patients with negative findings who have bled *only once* before curettage, 70-80 per cent do not bleed again afterwards.

## Investigation and Treatment

Postmenopausal bleeding or discharge calls for immediate investigation, even though there is only a single episode. Even when there is a history of oestrogen therapy (*see above*), transvaginal ultrasonography,



endometrial aspiration and possibly hysteroscopy and colposcopy-guided cervical biopsy are necessary. This is true even if vaginal and cervical smears and endometrial aspirates are negative for cancer cells; it is true even when an adequate cause for bleeding such as a cervical polyp or senile vaginitis is found. The presence of such lesions does not exclude the presence of carcinoma of the uterus; indeed, a cervical polyp stands in the same relation to carcinoma of the body of the uterus as do haemorrhoids to carcinoma of the rectum.

If standard tests do not show the lesion, there is a case for doing a CT scan or an MRI of the pelvis to exclude a genital lesion.

When a cause is found, treatment is directed to it. When no cause is found in the genital tract, and the bleeding occurs repeatedly, its origin from another site has to be excluded. This means a full study of the urinary system and lower bowel, including cystoscopy and sigmoidoscopy. The recurrence or persistence of bleeding *per vaginam* after all investigations have given negative findings always calls for laparotomy with a view to hysterectomy. This may be the only means of detecting an early carcinoma of the uterus, the tube or the ovary.

### Menopausal Transition

Beginning at the age of 40 years, routine health maintenance should include screening for problems related to hormonal changes. Questions concerning changes in menstrual function, abnormal bleeding, hot flashes, sleep disturbances, and sexual function should be asked routinely.

### Abnormal Bleeding

Menstrual irregularity occurs in more than one-half of all women during the menopausal transition. Uterine bleeding can be irregular, heavy, or prolonged. In most cases, this bleeding is related to anovulatory cycles. This disruption of normal menstrual flow has been attributed to a gradual decrease in the number of normally functioning follicles and is reflected by a gradual increase in early follicular-phase FSH levels.

Although anovulation is one of the more common causes of abnormal uterine bleeding, pregnancy must always be considered. There are numerous reports of pregnancies in women in their late 40s who did not consider themselves fertile. In these women, abnormal bleeding may be the first indicator of an unexpected pregnancy.

Endometrial cancer should be suspected in any perimenopausal women with abnormal uterine bleeding. After menopause, the overall incidence of endometrial cancer is approximately 0.1 per cent of women per year, but in women with abnormal uterine bleeding, it is about 10 per cent. This risk is increased at least fivefold in women with a history of unopposed oestrogen use and decreased by more than two-thirds in women taking a combination of oestrogen and a progestin.

Malignant precursors such as complex endometrial hyperplasia become more common during the menopausal transition. Because early diagnosis is the most effective way to improve a woman's prognosis, perimenopausal women with abnormal uterine bleeding should undergo an endometrial biopsy to exclude a malignant condition. Other causes that should be considered when a woman experiences abnormal uterine bleeding include cervical cancer, polyps, or leiomyomata.

### Evaluation

The goal of evaluation of abnormal uterine bleeding is to achieve the greatest accuracy with the least risk and expense for the patient. In the past, when few diagnostic options were available, this condition was routinely managed with inpatient uterine curettage. However, with the development of less invasive office procedures and more accurate outpatient surgical approaches, uterine curettage without hysteroscopy is seldom done.

### Vaginal Ultrasonography

With the advent of newer diagnostic modalities, vaginal ultrasonography has become an established first step in the evaluation of perimenopausal bleeding. In premenopausal women, vaginal ultrasonography is extremely useful for identifying leiomyomata and endometrial asymmetry suggestive of endometrial polyps. When combined with saline injection, sonohysterography can accurately visualise polyps and other focal intrauterine lesions.

In postmenopausal women, vaginal ultrasonography, with or without saline injection, is even more helpful than in premenopausal women. An endometrial stripe <5 mm thick has been shown to be associated with an extremely low risk of endometrial hyperplasia or cancer. A thickened or asymmetric endometrial lining or an obvious intrauterine lesion is an indication for more thorough evaluation. Likewise, refractory abnormal uterine bleeding in a high-risk patient is an indication

for endometrial biopsy even in the presence of reassuring ultrasonographic findings.

### Endometrial Sampling

The importance of the endometrial biopsy cannot be overemphasised for the pre- or postmenopausal woman with abnormal uterine bleeding. It is well accepted that endometrial biopsy performed in the office is just as accurate as dilation and curettage and certainly more economical. Although vaginal ultrasonography has changed the way, patients with abnormal uterine bleeding are evaluated, endometrial biopsy continues to be the most accurate screening method available for these patients. Dilation and curettage in the operating room with adequate anaesthesia should be reserved for patients with abnormal endometrial biopsies or for

conditions that preclude performing an office biopsy, such as cervical stenosis.

### Hysteroscopy with Uterine Curettage

The addition of hysteroscopy to uterine curettage has greatly improved diagnostic accuracy in the evaluation of focal intrauterine lesions. It allows for visual inspection of the endometrial cavity and gives the physician the opportunity to perform directed biopsies. Endometrial polyps or submucosal leiomyomas can easily be identified by hysteroscopy. As with many high-technology approaches, however, hysteroscopy requires appropriate training and equipment to ensure patient safety. If hysteroscopy is unavailable, dilation and curettage remains an accepted method for evaluation of the endometrium.

Primary Dysmenorrhoea	617
Secondary Dysmenorrhoea	622
Membranous Dysmenorrhoea	624
Other Conditions Simulating Dysmenorrhoea	624

## INTRODUCTION

Dysmenorrhoea means difficult menstruation but the term is used to mean painful menstruation. Dysmenorrhoea is of two types:

- A pain which is of uterine origin and directly linked to menstruation but with no visible pelvic pathology. This is *primary, idiopathic or true dysmenorrhoea*.
- A pain which is associated with uterine or pelvic pathology. This is *secondary dysmenorrhoea*.

If these two groups are not to be confused, and if mistakes over diagnosis and treatment are to be avoided, every patient complaining of dysmenorrhoea must be asked: When do you feel the pain? Does it ever occur apart from menstruation? What is its relation to the first day of the period? On which days is it most intense? How long does it last? Where is the pain situated? Primary dysmenorrhoea is essentially a first-day pain (*spasmodic dysmenorrhoea*) while secondary dysmenorrhoea may continue throughout the flow or may be *congestive* in type; it is worse premenstrually and is relieved during the flow. A pain which is equally severe before, throughout and after menstruation is likely to have its origin in the psyche; no pelvic lesion can cause such a pain.

## PRIMARY DYSMENORRHOEA

Primary dysmenorrhoea refers to presence of painful menses where there is no underlying pathology that can account for pain.

### Frequency

Not less than 50 per cent of women are said to experience some discomfort in relation to menstruation, and 5-10 per cent of girls in their late teens and early twenties are incapacitated for several hours each month. Estimates vary widely because of differences in the criteria of dysmenorrhoea and because most investigations concern only one section of the community. The incidence of dysmenorrhoea is affected by social status, occupation and age, so groups of schoolgirls, college students, factory workers, and women members of the armed forces each provide different statistics.

The number of girls complaining of incapacitating true dysmenorrhoea has decreased considerably during the last 20-30 years. Indeed, it is now rare to see them in a hospital outpatient department. This may reflect a more sensible outlook and upbringing of the modern generation, or the availability of more effective over-the-counter drugs, or both.

## Aetiology

### *Behavioural and Psychological Factors*

Just before and during menstruation most women are less efficient physically and more unstable emotionally; these factors alone lower the pain threshold. Dysmenorrhoea may even be an excuse to avoid doing something which is disliked. The expectation of pain may be fostered by overanxious parents and by curtailment of normal activities during menstruation. *A dysmenorrhoeic mother usually has a dysmenorrhoeic daughter. A girl who is an only child is more likely than most to suffer from dysmenorrhoea.* It is often very difficult to separate the respective contributions of physiological and psychological factors and such factors may make dysmenorrhoea worse even if they do not cause it; these include unhappiness at home or at work, unsatisfied sex urge, fear or loss of employment, and anxiety over examinations. Marriage may cure by removing the tension of a long engagement and by providing happiness and security; on the other hand, if it proves disharmonious, it can cause dysmenorrhoea.

### **Muscular Incoordination and Uterine Hyperactivity**

Spasmodic dysmenorrhoea could be due to incoordinate muscle action of the uterus as a whole. If so, it could be explained by an imbalance in the autonomic nervous control of muscles, in which an overactive sympathetic system leads to hypertonus of the circular fibres of the isthmus and the internal os. This would fit in with the general nervous instability of many of these patients and also with the other manifestations of autonomic upset — such as bowel and bladder tenesmus — which accompany dysmenorrhoea. It does not, however, explain why dysmenorrhoea is cured by age and by childbearing.

## Hormone Imbalance

Spasmodic dysmenorrhoea has some connection with progesterone stimulus to the uterus. It only occurs in ovular cycles, and it is suggested, but not proved, that the occurrence of anovular menstruation explains the absence of dysmenorrhoea during the few years following the menarche and the occasional painless period even at a later age. Another observation is that progesterone induces high tone in the isthmus and upper cervix. An exaggeration of this could therefore be the basis of the incoordinate action of the uterus. The close relationship between dysmenorrhoea and a progesterone influence, and also the cure of the complaint by permanent dilatation of the cervix, obstetrically or surgically, can also be explained. A difference in the isthmic tone between the uteri of nulliparous and multiparous women, and between those of dysmenorrhoeic and non-dysmenorrhoeic women, has been demonstrated.

## Prostaglandins

The most favoured view is that dysmenorrhoea is associated with an excess of prostaglandin  $F_{2\alpha}$  in the uterus. It has been demonstrated that secretory endometrium contains more prostaglandins than proliferative endometrium. Prostaglandins are known to increase myometrial contractions and constrict small endometrial blood vessels to produce ischaemia and breakdown of the endometrium, bleeding and pain. Increased levels of prostaglandin  $E_2$  are seen in these patients and may increase the sensitivity of the nerve endings to pain.

Prostaglandin synthetase inhibitors relieve the symptoms in about 80 per cent of patients with dysmenorrhoea; which supports the view that excessive prostaglandin activity is a major factor in its aetiology.

## Other Factors

Circulating vasopressin levels are higher in women who have dysmenorrhoea. Vasopressin stimulates uterine contractility. Leukotrienes and endothelins also increase myometrial contractility but their role in dysmenorrhoea is unclear.

It is postulated that nerve endings in the muscle and cervix are destroyed by pregnancy and this may explain how primary dysmenorrhoea is often cured after the birth of a baby.

## Clinical Features

In primary dysmenorrhoea, the pain sensation arises in the uterus and is related to muscle contractions. It is experienced a few hours before and after the onset of menstruation and rarely lasts in a severe form for longer than 12 hours. It is colicky in type, although the patient does not always recognise the periodic exacerbations and may describe a constant ache which causes her to 'double up'. The pain is felt mainly in the hypogastrium and is often referred to the inner and front aspects of the thighs; *it never extends below the level of the knee and is never experienced in the back of the leg*. There may be some low backache as well but this is not the dominant sensation. The cutaneous areas of pain reference are innervated by the iliohypogastric and ilioinguinal nerves (T12, LI and L2).

During a severe attack the patient looks drawn and pale and may sweat; nausea and vomiting are common; there may be diarrhoea and rectal and bladder tenesmus. All these features suggest an upset in the autonomic nervous system.

In at least 50 per cent of cases the pain does not arise until 6-12 months after the menarche; in others close inquiry usually reveals that even though the initial periods were painful, *severe* dysmenorrhoea only appeared 2-4 years later. A description of intense pain dating from the menarche should raise doubts about its reality. Primary dysmenorrhoea reaches a maximum between the ages of 18 and 24 years and thereafter diminishes. It is exceptional for it to begin after the age of 25 years and it begins to decline beyond the thirtieth year. Moreover, it is nearly always cured by pregnancy, labour at term being more certain to have this effect than early abortion. One explanation is that pregnancy improves the vascularity and development of the uterus, but the dilatation of the cervix associated with delivery is probably the more important factor. Previous spasmodic dysmenorrhoea is *not* related to abnormal uterine action in labour.

## Treatment

A sympathetic approach to the patient including consideration of psychological and behavioral elements will help in a positive outcome. Flow chart 39.1 shows an approach to management of a case of dysmenorrhoea.

## Prevention

One hope of limiting the intensity of spasmodic dysmenorrhoea, or the incapacitation it causes, lies in teaching young girls a proper outlook on menstruation, sex and health in general.

### General

Unfavourable environmental factors, malnutrition, general ill health and any errors in the patient's mode of life should be corrected. Regular physical activity is to be encouraged both between and during menstruation but the value of set remedial exercises has been over-rated. While the pain is at its highest, the girl may have to lie down and obtain relief from warmth applied to the lower abdomen.

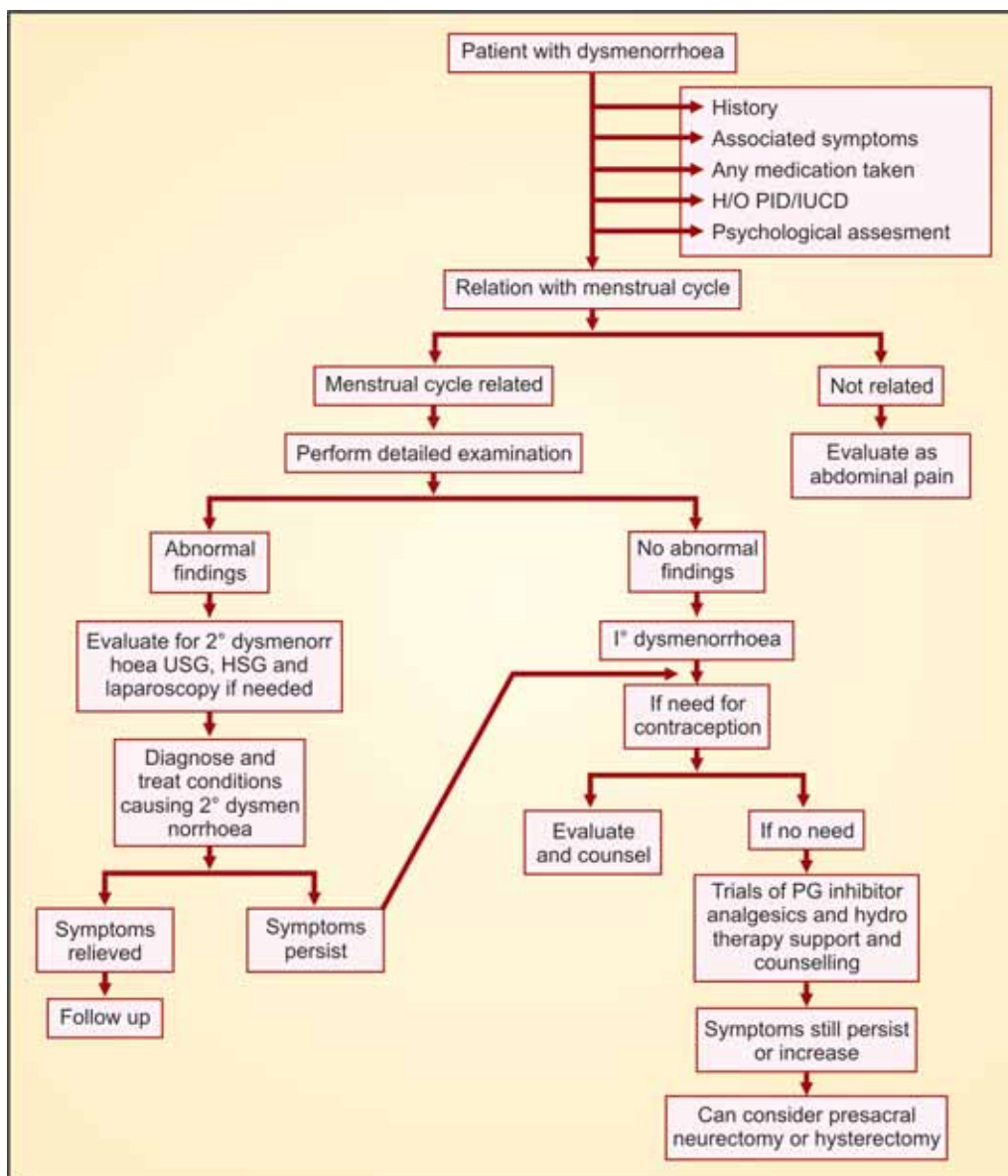
In the majority of cases nothing more than general advice, reassurance and empirical relief of pain are necessary. It is important that the girl should realise that her complaint is likely to be short-lived and that the immediate prospects of childbearing justify the deferment of drastic measures.

## Drugs

### Prostaglandin Synthetase Inhibitors

The nonsteroidal anti-inflammatory drugs (NSAIDs) which are active inhibitors of prostaglandin synthetase are very effective. They also compete for prostaglandin binding sites. Any of the following may be used: indomethacin, 25 mg three to four times daily; ibuprofen 400 mg three times daily; naproxen sodium 250 mg thrice daily; ketoprofen 50 mg thrice daily; mefenamic acid 250 or 500 mg two to four times daily; and piroxicam 20 mg once or twice daily. Patients may adjust their own dosages and timing of medication experimentally to assess the regimen most effective for themselves. The drugs are usually required for 1-3 days from the onset of a period. Continuous therapy during the period gives better results than administration on an as-needed basis. The fenamates are the most effective and are virtually free from side-effects. However, their use is contraindicated in women with gastrointestinal ulcers, bronchial asthma and hypersensitivity to aspirin. Side-effects include nausea, vomiting, diarrhoea, abdominal pain, constipation, heartburn and dizziness. Less commonly, patients may have bronchospasm, melena, hearing disturbances, drowsiness, skin rash, haematologic and renal function abnormalities.

Flow chart 39.1: Management of dysmenorrhoea



Pethidine, morphine and the newer powerful analgesics should *never* be prescribed.

### Hormone Therapy

Anovulatory cycles are always painless; so suppression of ovulation gives certain relief from primary dysmenorrhoea. This is best achieved by means of one of the oestrogen-progestogen oral contraceptive preparations. One pill is taken nightly on each of the fifth to twenty-fifth days of the cycle.

It is remarkable that despite giving progestogen, the subsequent period is always painless if ovulation is suppressed; this undermines the previously expressed views on why ovulation causes spasmodic dysmenorrhoea.

Hormone therapy is the treatment of choice for the woman who desires contraception. When prostaglandin inhibitors fail or are contraindicated, hormone therapy is the best form of treatment for the older teenager who has achieved her full stature. The relief of dysmenorrhoea

is generally limited to the cycle treated, but cyclical hormone therapy continued for 6 months sometimes appears to have a more lasting effect. Or perhaps it offers the girl relief until she is cured spontaneously. Prolonged suppression of the endometrium reduces the prostaglandin content, and over a period of time the production of a relatively atrophic, decidualised endometrium is associated with low-prostaglandin menstruation, free of pain. The combined oestrogen-progestogen pill is ideal if contraceptive measures are required in addition to relief of dysmenorrhoea.

As a temporary measure antioviulatory preparations are especially indicated in the following circumstances: to tide a patient over an important engagement which may clash with a painful period; or as a diagnostic measure in those cases where there is doubt whether the complaint of dysmenorrhoea is genuine.

#### Calcium Channel Blockers

Patients with intractable dysmenorrhoea with no demonstrable pelvic pathology often respond well to nifedipine.

### Surgical Treatment

Surgery for primary dysmenorrhoea is considered only when the pain is so severe as to be incapacitating, when medical treatment has failed, and when a significant psychological or pathological basis is excluded. It is rarely indicated, and hardly ever before the age of 18 years. Impending marriage and childbearing, as well as the hazards and poor results of surgery, justify procrastination.

#### Laparoscopy

If the patient has received adequate medical therapy over 4-6 cycles and has not shown satisfactory response, a diagnostic laparoscopy should be considered to rule out any pelvic lesions causing secondary dysmenorrhoea. If present, these can be treated simultaneously.

#### Dilatation of the Cervix

The object of this operation is to stretch the fibromuscular tissue at the level of the internal os to such an extent as to render it hypotonic. Some believe that the adjacent nerve fibres are also damaged. Usually a good deal of resistance is encountered during dilatation; if this

is absent it means that the case has been ill chosen and that a cure is unlikely. The dilatation is carried out slowly and continued up to Hegar 10. The operation can be very difficult and involves a real danger of injury to the cervix which may result in recurrent abortion in later life. Dilatation is rarely justified on its own but may be done along with laparoscopy.

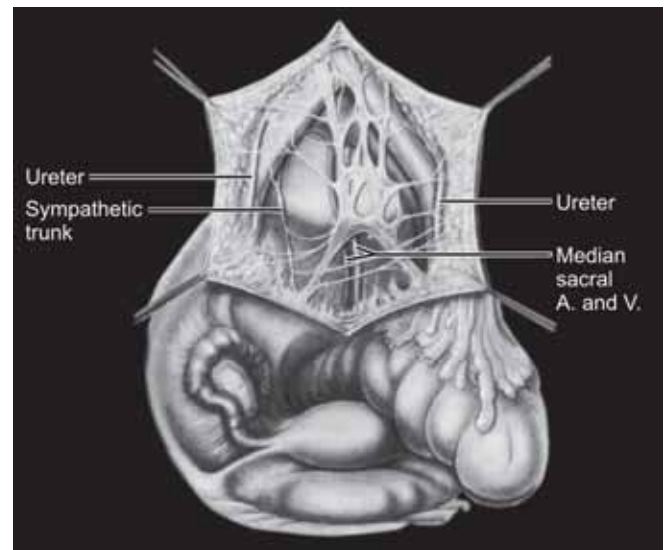
#### Injection of the Pelvic Plexus

Injection of the Lee-Frankenhauser plexus with anaesthetic agents can be combined with dilatation of the cervix, or carried out alone. The results are equivocal so the treatment has few advocates. It might have a place as a therapeutic test before resorting to sympathectomy.

#### Presacral Neurectomy (Fig. 39.1)

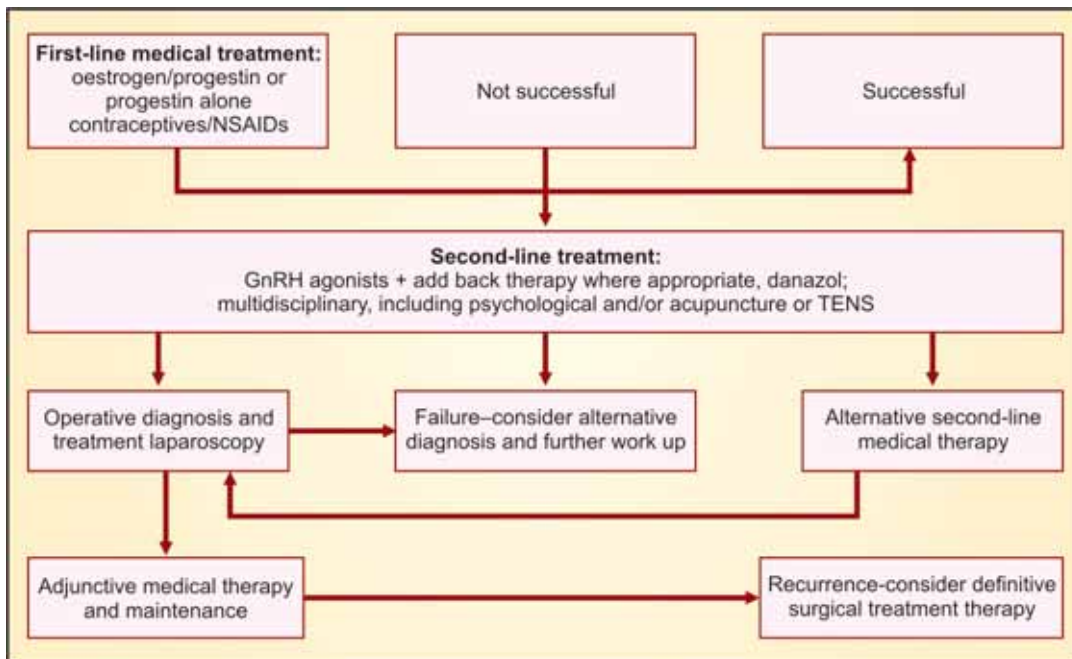
The postulated objectives of this operation are to eliminate motor impulses which may be responsible for uterine spasm; to increase the vascularity of the uterus; and to interrupt the sensory pathways from the uterus. The last is probably the main effect. Flowchart 39.2 enumerates which case are to be selected for surgical therapy.

Presacral neurectomy is never justifiable unless all the simpler procedures have failed. This means it is



**Fig. 39.1:** The presacral nerves exposed as in the operation of presacral neurectomy. The peritoneum over the bifurcation of the aorta and the promontory of the sacrum has been incised vertically to show not only the sympathetic nerves but also the other retroperitoneal structures in close relation to them

Flow chart 39.2: Management of a case of dysmenorrhoea after failed first line therapy



usually reserved for the most hopeless patients and the results in the hands of most gynaecologists are therefore very unsatisfactory. The few who practise presacral neurectomy as a primary procedure, and therefore on more promising material, claim a high cure rate and explain failures on the basis of technical errors such as omission to divide all the nerves. For this reason, some surgeons combine presacral neurectomy with lumbar and ovarian sympathectomy, and with section of the uterosacral ligaments to catch fibres going to the sacral plexus.

Under modern conditions I do not consider presacral and other forms of neurectomy to have any place in the treatment of spasmodic dysmenorrhoea. Presacral neurectomy may have a place in intractable cases associated with pelvic pathology, such as endometriosis which fails to respond to medical therapy. Currently laparoscopic ultrasound nerve ablation (LUNA) is done in such patients along with laparoscopic surgery for the endometriosis but long-term results are still awaited.

### Results

When dealing with a subjective symptom which is prone to spontaneous cure, it is difficult to assess results. Nevertheless, good medical management is effective in

80-95 per cent. Otherwise, the many forms of treatment recommended, which range from physiotherapy, psychotherapy and hypnosis to sympathectomy, give relief in 60 per cent of cases, and so do placebos.

## SECONDARY DYSMENORRHOEA

### Aetiology

Pelvic lesions at various sites can result in secondary dysmenorrhoea.

Secondary dysmenorrhoea arising after the age of 30 years always suggests the possibility of endometriosis. Some cases are deceptive in which the patient has had dysmenorrhoea in her youth and the change from one type of pain to another passes unnoticed. The pain of endometriosis varies in position with the site of the lesion. It is experienced as an increasing ache for 2 or 3 days premenstrually but reaches its climax *during or at the end of the period* when the endometriosis is menstruating into itself. Unlike spasmodic dysmenorrhoea, the pain persists for several days and only ceases completely after the period is over, when some of the menstrual exudate is absorbed.

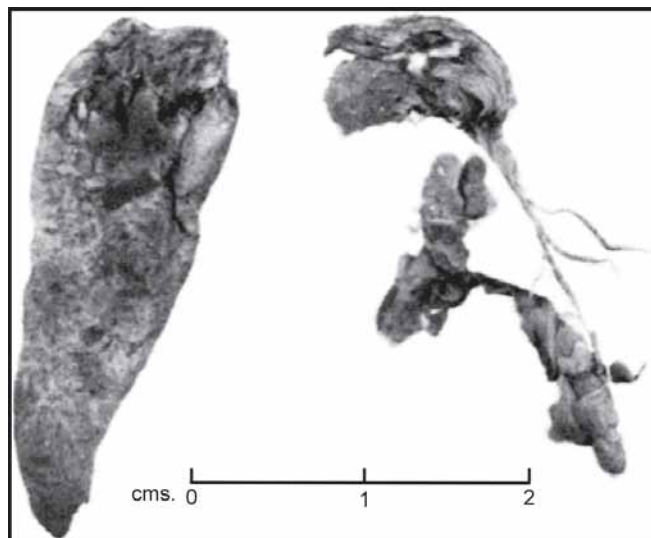
The *Allen-Master syndrome* and pelvic congestion involve the peritoneum and cause secondary dysmeno-



rrhoea. The ovary may be the seat of an endometrioma or other tumour. Acute and chronic pelvic inflammatory disease may result in pelvic congestion. A broad ligament varicocele is sometimes present. In this condition the pampiniform plexus of veins in the broad ligaments is dilated, the suggested aetiology being the same as for varices in the legs and anal canal. A varicocele can be demonstrated by colour doppler. However, it is not clear whether broad ligament varicosities are usually the result or the cause of venous stasis.

In the uterus, adenomyosis, leiomyomas, polyps and an intrauterine device can lead to secondary dysmenorrhoea. Adenomyosis of the uterine wall rarely causes dysmenorrhoea because its endometrial elements have a limited menstrual function. Leiomyomas cause dysmenorrhoea only when they are in special sites. The expulsion of large clots of blood during menstruation is rarely seen except as an accompaniment of menorrhagia (Fig. 39.2). Expulsive contractions cause miniature 'labour pains' which are only noticed immediately before the appearance of the clot. They are usually not as severe as those occurring in primary dysmenorrhoea.

Congenital malformations of the uterus are also implicated. The abnormal muscle arrangement in the septate and bicornuate uterus can give rise to intractable if not severe colic, but the unicornuate uterus and the uterus didelphys are less likely to cause trouble. Each half of the uterus gives rise to pain referred to its own side of the lower abdomen and, when only one horn is

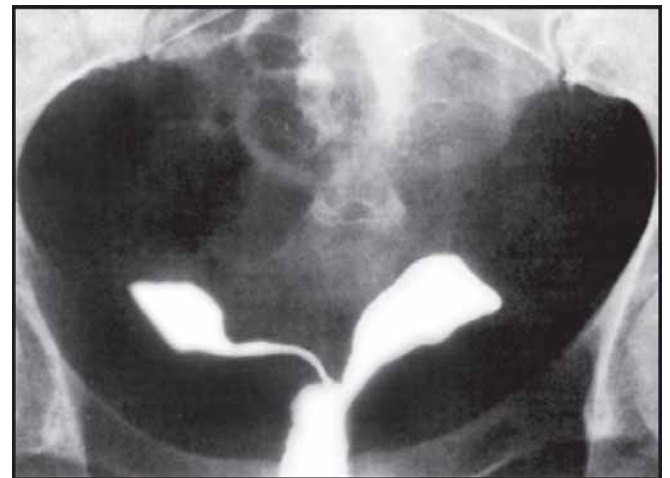


**Fig. 39.2:** Blood casts from the uterus in a case of spasmodic dysmenorrhoea associated with the passage of clots

at fault, the dysmenorrhoea is unilateral. One-sided *spasmodic* dysmenorrhoea in a young patient should always raise the possibility of a uterine malformation. When a rudimentary horn causes pain, it is usually because it does not communicate with the uterine canal and the outflow of blood from it is obstructed. In many cases, however, it is the better developed and functional horn which is the source of the pain (Fig. 39.3). Other causes of *one-sided dysmenorrhoea* experienced in the lower abdomen may be endometriosis with a unilateral distribution; a small leiomyoma at the uterotubal junction — the site of origin of uterine contractions. The last is easily the commonest. Cervical stenosis, imperforate hymen or transverse vaginal septum cause cyclical pain once a haematometra develops.

### Clinical Features

Secondary dysmenorrhoea usually develops after a phase of painless cycles and is seen at an older age. However, endometriosis can rarely occur at or shortly after menarche. History and physical examination aid in elucidating most of the aetiological factors. The pain may be spasmodic in type, or it may be congestive. Congestive dysmenorrhoea (Taylor syndrome) takes the form of a diffuse dull ache in the pelvis, often accompanied by backache, and is thought to be the result



**Fig. 39.3:** Hystero-gram showing unequal development of the two horns of a bicornuate uterus. In such a case, spasmodic dysmenorrhoea, if present, might be unilateral. But the pain would most likely arise from the better developed horn. A rudimentary horn only causes dysmenorrhoea when it fails to communicate with the cervix and becomes the seat of a haematometra. (see Fig. 13.3)

of increasing tension in the pelvic tissues associated with inflammation exacerbated by premenstrual engorgement. The pain is therefore at its height during the 2 or 3 days preceding menstruation and is slowly relieved as congestion is reduced with the onset of menstruation. It is frequently associated with menorrhagia or polymenorrhoea, and often forms part of the premenstrual syndrome. The backache element may be the result of hormone influences on the joints of the spine and pelvis but this mechanism almost certainly does not account for the pelvic discomfort. The differential diagnosis of secondary dysmenorrhoea includes primary dysmenorrhoea and chronic pelvic pain. Orthopaedic conditions affecting the lower back can cause premenstrual backache but rarely, if ever, result in a pain referred to the abdomen.

### Investigations

2° dysmenorrhoea can be easily diagnosed from the history of patient.

Important investigation to help in identifying the cause are:

- a. Laparoscopy — Single and most useful diagnostic procedure
- b. Pelvic ultrasound — will show ovarian endometriosis and demonstrate complexity of ovaries in PID
- c. Hysterosalpingogram — Useful in identifying intrauterine adhesions
- d. Microbiological cultures — From endocervix or peritoneal fluid in suspected PID
- e. MRI is best for diagnosis of congenital uterine anomalies.

### Treatment

In secondary dysmenorrhoea treatment is directed to the underlying condition; supportive measures with analgesics may be used. In IUCD users and in women with leiomyomas and endometriosis, prostaglandin synthetase inhibitors can provide relief of pain and reduce the amount of bleeding. If this is not sufficient, definitive treatment is needed as indicated in the relevant sections. IUCD users must select an alternate method of contraception. The underlying cause of menorrhagia must be explored and managed. A rudimentary horn is best excised, especially if it is the seat of a haematometra. Reconstruction operations on bicornuate uteri usually give unsatisfactory results as far as dysmenorrhoea is concerned.

### MEMBRANOUS DYSMENORRHOEA

This is a very rare condition with a familial incidence in which the endometrium, instead of being fragmented, strips off in large pieces or even as a whole cast of the uterus; the passage of these is preceded and accompanied by severe colic. Its pathogenesis is obscure. The traditional explanation is that an overmature corpus luteum induces an excessive decidual reaction to make the surface endometrium so compact that it will not easily disintegrate. Although an excessive production of progesterone in these cases has never been demonstrated, and the endometrial cast sometimes fails to show a strong decidual change, the condition has been produced experimentally with progesterone. In certain cases the fault may lie in the sensitivity of the endometrium rather than in its hormone stimulus.

Membranous dysmenorrhoea does not interfere with conception and pregnancy, nor is it cured by childbearing. Indeed it is refractory to all treatment including curettage. Suppression of ovulation by means of an oestrogen-progestogen preparation, administered cyclically for 1-2 years, is said to be effective in some cases.

### OTHER CONDITIONS SIMULATING DYSMENORRHOEA

#### Menstrual Pain of Ovarian Origin

##### *Corpus Luteum Haematoma*

A comparatively rare and isolated accident is haemorrhage into and from the corpus luteum. This may be spontaneous but can be precipitated by direct injury such as might be sustained during coitus, and possibly by physical exercise and sudden cooling of the body surface. The patient experiences an acute onset of a sharp pain, low in the abdomen to one or other side, and this may be followed by a feeling of faintness. Severe collapse can occur if there is much intraperitoneal bleeding and the picture then simulates that of ruptured ectopic pregnancy. Other similar features are a palpable small but tender swelling of one adnexum, generalised tenderness and distension of the lower abdomen. The pain is also usually followed by uterine bleeding which, in this condition, is the premature arrival of a menstrual period due to failure of corpus luteum function. Even at laparotomy the haematoma may be diagnosed as an ovarian pregnancy, the true nature of the lesion only

being recognised on histological examination. Rupture of an endometriotic cyst and torsion of a small ovarian tumour can also be confused preoperatively.

The clue to the diagnosis is that the symptoms begin during the second half of a previously regular cycle. It may be added, however, that the corpus luteum of early pregnancy can also bleed into its substance or into the peritoneal cavity. In that case it may be impossible, before operation, to distinguish the syndrome from ectopic pregnancy clinically. Ultrasound and serum (3 samples every 48 hrs)-hCG titres may help to clinch the diagnosis.

If the diagnosis of corpus luteum haematoma is made and it is clear that the haematoma is small and self-limiting, no treatment other than analgesics and continuous observation is necessary. The ovarian lesion resolves spontaneously. If, however, there are signs of significant intraperitoneal haemorrhage, then laparoscopy or laparotomy, with or without blood transfusion, is necessary. At operation the damaged ovary is preferably repaired but, rarely, may have to be removed; the peritoneal cavity is then cleared of blood.

## Ovulation Pain

### *Clinical Features*

Mid-cycle pain (*mittelschmerz*) is present from time to time during the menstrual life of almost 50 per cent of women, although it is often not recognised for what it is. The discomfort appears between the tenth and fifteenth days, is experienced in the hypogastrium or in one or other iliac fossa, and is occasionally referred to the rectum. Strangely enough, ovulation pain is nearly always on the same side and does not change from side to side according to which ovary is ovulating. It varies in severity but rarely lasts longer than 12-24 hours. It is sometimes accompanied by ovulation bleeding and may be present in one month and not in another.

### *Cause*

Ovulation pain is said to be caused by contractions of the tube or uterus; increased tension in the graafian follicle or the ovary; irritation of the peritoneum by the discharge of fluid and blood from the follicle; and muscle cramps in the caecum or pelvic colon. The timing of the pain and its relationship to daily temperature charts

suggest that it sometimes precedes ovulation and subsides before ovulation. The aetiology is uncertain because in other instances it occurs after ovulation. That it can persist when the tubes or the uterus are removed suggests that these organs are not ordinarily responsible for it. The fact that it recurs on the same side in many women suggests a bowel origin. Distension of the ovarian capsule by the developing follicle may explain some of the pain; leakage of fluid from the ruptured follicle which has been confirmed, would explain post-ovulation pain by causing local peritoneal irritation. So, it appears to have different mechanisms in different women.

### *Treatment*

Ovulation pain is rarely severe enough to merit more than reassurance and explanation. The patient is comforted if she is told that it is a sign that the ovary is working well and, in the case of right-sided pain, is particularly relieved to hear that she is not suffering from appendicitis. She may not be so relieved when she realises that the appendicectomy, previously carried out for this pain, was unnecessary.

If necessary the pain can be prevented in any one cycle by inhibiting ovulation with an oestrogen-progestogen preparation. Prostaglandin synthetase inhibitors are also effective but should be avoided if conception is desired as they interfere with the process of ovulation. I have never found it necessary to give any medical treatment for ovulation pain and a spontaneous cure is always likely.

## Orthopaedic Conditions Simulating Dysmenorrhoea

Many women alleged to have dysmenorrhoea indicate (*if asked*) that their pain takes the form of a low backache during the premenstrual phase. This symptom often dates from pregnancy. Yet careful inquiry reveals that the pain commenced *during* pregnancy, or that it dates from an injury or strain during the puerperium. Often the discomfort is situated too high to have a uterine origin, or it may be localised to one or other sacroiliac joint. It is sometimes referred to the buttock or over the course of the sciatic nerve and there is a clear relationship to posture and certain movements. All of these features exclude a pelvic cause, as does tenderness at the site of the pain.

Disc lesions and arthritic changes in the spine are possible findings but, in nearly all cases of premenstrual and menstrual backache, the patient is suffering only from a chronic muscular or ligamentary strain. The injury may well be a minor one which would quickly recover except for overwork and too many family responsibilities. The fact that symptoms are confined to, or are worse during, the premenstrual phase is explained by the softening effect of oestrogen and progesterone on all pelvic ligaments; this makes the joints less stable at that time and exaggerates any disability. The further clinical

features and treatment of these conditions are discussed elsewhere.

Pain in the knees with each menstrual period is an interesting but less well-known syndrome. It begins premenstrually, only lasts a few days, and is the result of fluid retention associated with high levels of steroid hormones. This causes swelling of the infrapatellar pads of fat which then become nipped in the joints. Apart from restricting the intake of fluid and salt, the patient should be advised to wear high-heeled shoes to prevent the nipping.

# CHAPTER 40

## Premenstrual Syndrome and Other Menstrual Phenomena

Premenstrual Syndrome	627	Pelvic Allergy	633
Menstrual Migraine	630	Vicarious Menstruation	634
Premenstrual Mastalgia	631	Cyclical Haemothorax and Pneumothorax	634
Recurrent (cyclical) Buccal and Vulvar Ulceration	631	Menstrual Epilepsy	636

### PREMENSTRUAL SYNDROME

#### Clinical Features

Most well-adjusted women experience minor psychological and somatic changes for a few days preceding menstruation. These menstrual molimina give way to a sensation of relief and well-being once menstruation is established. In some women these manifestations become exaggerated to constitute a *premenstrual syndrome (PMS)*. This is extremely common at all ages but especially in women aged 30-45 years, the reported prevalence ranging from 5 to 95 per cent. It is often wrongly attributed to an approaching menopause. The age incidence of PMS is said to be due to the fact that stresses are most severe in the third and fourth decades. The problem is a feature of modern conditions of life in Western civilised communities. It used to be rarely encountered in, or complained of, by women in Eastern countries, but with changing lifestyles this pattern is changing. It is certainly the cause of much individual misery and family disharmony, absenteeism and even criminal acts like murder and suicide.

The symptoms are any of those described elsewhere, accentuated to a pathological degree and present for as long as 7-10 days premenstrually. In some instances, the symptoms are so severe that the woman fails to cope with her ordinary day-to-day life. If the onset of a period is delayed, the symptoms become even more intense. The main complaints are headache, irritability, depression, lassitude, insomnia, emotional outbursts, intestinal distension, colonic spasm and congestive dysmenorrhoea. The patient herself is conscious of nervous tension and has a bloated feeling, often accompanied by an actual increase in girth and weight. In certain cases there is an obvious swelling of the legs caused by oedema.

Not all the various discomforts are present in each case; sometimes one is so prominent as to overshadow others and to justify it being regarded as a special clinical entity such as *menstrual migraine*, *menstrual oedema* and *premenstrual mastalgia* (see below).

The affected individual is often full of restless energy, cleaning the house when it is already spotless, fussing and nagging the children, worrying when there is no need. The husband cannot understand the periodic outbursts and moods; the resulting quarrels make the situation worse. It is the imaginative woman 'living on her nerves' who is most likely to suffer.

Examination is not usually helpful. Various questionnaires have been developed in an attempt to quantify the problem. These are designed to measure the severity of symptoms, underlying psychological dysfunction and the degree of disruption of normal functioning. Commonly used methods include visual analogue scales, psychiatric questionnaires, e.g. the General Health Questionnaire and Moos' Menstrual Distress Questionnaire.

### Aetiology

At the present time, despite intensive study, the aetiology remains unknown and there are many theories but no real explanation. There are undoubtedly physiological and psychological factors or components, which act to varying extents in different individuals.

The underlay of overanxiety and emotional instability, present in some (or, in the opinion of others, many) cases, makes it necessary to regard the condition as a psychosomatic disorder.

Neurotransmitters may play a role. The luteal phase levels of  $\beta$ -endorphins have been shown to be low in women with PMS and can lead to anxiety, food craving and physical discomfort. Low serotonin levels have also been demonstrated in RBCs and platelets. Treatment with fluoxetine, a selective serotonin re-uptake inhibitor, is effective in improving symptoms. Vitamin B<sub>6</sub> is a cofactor in the synthesis of serotonin and dopamine from tryptophan but its deficiency has not been clearly proved.

Although more than one mechanism may be concerned in the production of symptoms, an increase in extracellular fluid throughout the body is one which is often blamed. This explains why some affected women gain 1.8-2.3 kg weight just before a period. The oedema is said to be associated with sodium retention, and this in turn with high levels of both oestrogen and progesterone in circulation during the second half of the menstrual cycle. Oophorectomy, either surgically or medically (by the administration of GnRH analogues) eliminates the symptoms of PMS, whereas several

postmenopausal women who take HRT develop them, especially during the progesterone phase of the cycle. Another view is that it is the relative deficiency of progesterone which is the causal factor, but it is more likely that the swings in hormone level cause it. The subjective sensation of bloatedness may be due to gut distention.

However, most women who suffer from PMS do not put on weight. Controlled observations show that the incidence and intensity of symptoms is not related to weight gain. The tendency, therefore, is to credit the syndrome to a hypothalamic—pituitary disturbance. Such a basis would explain the cases in which fluid retention is a feature, as well as those in which it is not. It would also account for certain symptoms which have been attributed to neuro-vascular instability and hypoglycaemia.

Defective essential fatty acid or prostaglandin metabolism is postulated to result in an exaggerated response to normal ovarian hormone levels through a change in the receptor status at the cellular level.

Other theories to explain PMS include excess prolactin secretion and an increased production of aldosterone. There are no really good control-based studies due to the wide variations in the syndrome.

### Differential Diagnosis

Psychiatric problems, familial disharmony and hyperthyroidism may lead to irritability and behavioural change. A premenstrual pelvic pain may be caused by pelvic inflammatory disease or endometriosis. Underlying breast lesions should be ruled out in cyclical mastalgia.

Lethargy may be due to hypothyroidism or anaemia which must be looked for and treated.

### Treatment

#### General

The most important line of treatment is the correction of environmental causal factors. A sympathetic inquiry into personal problems and worries, and a reasonable explanation of the situation to both the patient and her husband may do more good than any specific medical remedies. Since the woman is overdriving herself, nervously if not physically, reorganisation of her life or her outlook on life is often necessary. A mid-day nap for 2 hours *every* day is particularly helpful.

All treatment should be considered on the basis of a therapeutic trial (Flow chart 40.1), for the responses of individual women vary as much as the symptoms. Some respond to one treatment and not to another.

*Pyridoxine*

Although, as discussed above, neurotransmitter abnormalities or vitamin B<sub>6</sub> deficiency has not been documented, there is improvement with pyridoxine though this could partly be placebo effect. With prolonged use of the high doses required (100 mg daily) there is concern about development of peripheral neuropathy.

*Elimination of Fluid*

In those cases in which a temporary increase in weight is a feature, the prevention of the accumulation of fluid in the tissues is the best form of symptomatic treatment. For this, the intake of fluid should be limited for 7-10 days premenstrually, and at the same time the diet

should contain as little sodium as is reasonably possible. When fluid retention is considerable, a therapeutic trial of spironolactone may be tried 10-14 days prior to the expected period. As there is no conclusive evidence that diuretics are effective in the relief of premenstrual tension, patients must be cautioned against addiction and indiscriminate use.

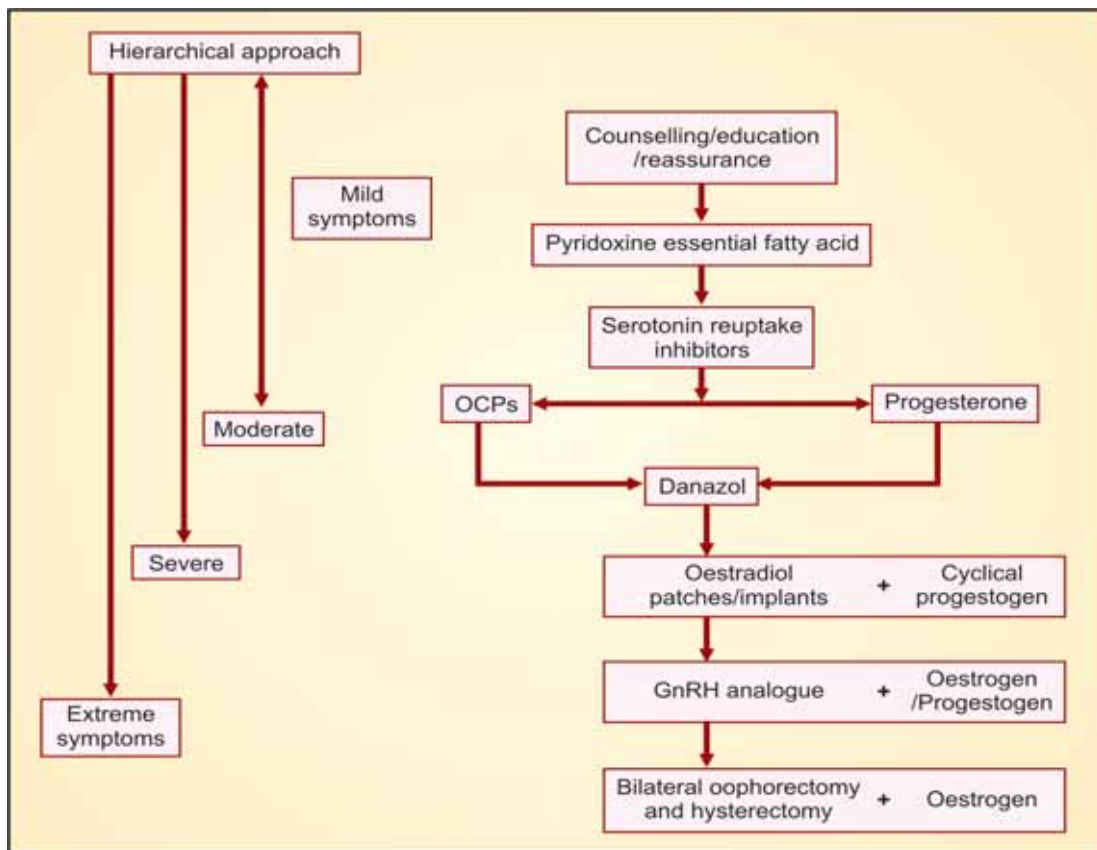
*Evening Primrose Oil*

The polyunsaturated fatty acids linoleic and gamma-linolenic acids are the dietary precursors of prostaglandin E. These are present in the oil of evening primrose.

*Serotonin Re-uptake Inhibitors*

Fluoxetine has been found to be effective with good long-term results. It is administered for 7-14 days in the luteal phase, in a dose of 20 mg daily or throughout the month. Response is seen in 2-3 months.

Flow chart 40.1: Management of premenstrual syndrome



## Hormones

Hormone therapy should only be prescribed when other measures fail. Oestrogen, progestogen and androgen have all been advised and used, the rationale depending on different theories of the causation of symptoms. However, it is probably more effective to eliminate endogenous hormone variations by the administration of daily oral contraceptive pills, or progestogens, e.g. dydrogesterone 20 mg daily, oral medroxyprogesterone acetate 10-30 mg daily or depot medroxyprogesterone acetate 150 mg i.m. every 3 months. The patient should understand that this therapy is empirical and benefits may well be due to placebo effect.

GnRH agonists have had success in 60-70 per cent of patients with PMS. This medical oophorectomy has significant side-effects. Combining it with oestrogen-progestogen add-back decreases the side-effects but also the efficacy of treatment of PMS.

## Other Drugs

Bromocriptine has been tried but it best relieves cyclical breast symptoms. While some of the other symptoms are relieved or made tolerable, the overall benefit is not significantly greater than that obtained by the combination of placebo therapy and a caring physician.

When there is emotional instability and anxiety, mild tranquillizers are beneficial. Most proprietary remedies contain mixtures of vitamins and micronutrients while others contain tranquillizers, anti-histamine stimulants, and progestogens as well.

## Surgery

In some extreme cases, relief may not be obtained with any medication. Total abdominal hysterectomy with bilateral salpingo-oophorectomy has been recommended for these women, followed by HRT with unopposed oestrogen. However, since this is an extreme step, a test with a GnRH analogue should be done to confirm that the procedure will indeed be effective. Adequate counselling is essential.

## MENSTRUAL MIGRAINE

### Clinical Features

The patient ordinarily susceptible to migraine is most liable to attacks before and at the time of menstruation, but the term *menstrual migraine* is usually restricted to

those cases in which attacks occur only at the time of menses. The condition is often familial. The headaches are localised to one area and are severe enough to be incapacitating; they are often accompanied by nausea and vomiting but are not usually preceded by visual, sensory and speech disturbances as in the case of classical migraine. Pregnancy usually brings temporary relief after the first trimester but migraine can be very troublesome during lactation. The menopause does not necessarily cure them, and headaches may continue as part of a climacteric syndrome.

### Aetiology

The aetiology of menstrual migraine is multifactorial and similar to migraine in general. An attack is more likely if the individual is overtired, overworked, or overwrought; excessive smoking is a contributory factor in some cases.

The cause of the headaches can be attributed to an allergic reaction to gonadotrophin; swelling of the pituitary gland; cerebral congestion and oedema; increased intracranial pressure; a local release of serotonin; cerebral ischaemia; and psychological factors.

In all probability, menstrual migraine is associated with changes in the cranial and cerebral vascular apparatus, or in the sodium and fluid content of cerebral tissues, and is to be regarded as part of, or a type of, PMS. Oestrogen and progesterone must be concerned with these changes because similar migraine sometimes results after the taking of the contraceptive pill. It is possible that changes in the hormonal milieu produce the setting for vascular headaches. A fall in oestrogen levels may lead to cerebral vascular spasm.

### Treatment

#### General

Attention to general health and change in lifestyle are important. Visual defects, sinusitis and dental diseases must be excluded.

#### Hormone Therapy

Since menstrual headaches occur in response to cyclic variations in circulating levels of oestrogen and progesterone, daily administration of exogenous hormones, i.e. combined oral contraceptive pill or medroxyprogesterone acetate, is effective in preventing migraine headaches in many women. Tamoxifen and danazol have also been reported to be effective. The true



severe migraine headaches with aura should not be treated with hormones and are, in fact, an indication for discontinuing oral contraception.

### *Symptomatic*

An attack may be prevented by giving drugs such as phenobarbitone, belladonna, and chlorpromazine, singly or in combination on the day before or at the onset of a period.

If, despite these and other measures described above, an attack of migraine occurs, the earlier that treatment is given, the better the result. With the patient at rest in a darkened room the drugs of first choice to relieve pain are aspirin, paracetamol or NSAIDs. The occurrence of vomiting, however, limits their usefulness.

A specific remedy is ergotamine tartrate (a serotonin agonist) with or without caffeine, which can be given orally. A 2 mg dose is followed by 1 mg every 30 minutes, if required, up to a maximum of 4-6 mg. The weekly dose should not exceed 10 mg.

Antiemetics such as metoclopramide by mouth, or if vomiting is likely, by intramuscular injection, relieve the nausea associated with migraine attacks. Phenothiazine and antihistamine antiemetics may also be used. Sumatriptan, a serotonin receptor agonist, is used in oral doses of 25-100 mg per attack. Preloaded syringes carrying 6 mg of drug are available in some countries for self-administration subcutaneously.

A safer and equally effective drug is clonidine hydrochloride, one tablet of 0.025 mg by mouth two or three times daily. It is, however, more often used to prevent attacks.

### *Artificial Menopause*

The patient sometimes demands the induction of the menopause which she believes will lead to permanent relief. This treatment should be avoided because, to be effective, ovarian function has to be destroyed and, in the type of woman under consideration, the end result may be climacteric headaches and other symptoms, which can be even more troublesome.

## PREMENSTRUAL MASTALGIA

### Clinical Features

Approximately 80 per cent of women experience slight fullness, tingling and tenderness of the breasts during the week preceding menstruation. When this is

exaggerated it becomes part of PMS and is termed *premenstrual mastalgia*. The breasts may then feel tense, knotty and tender and there is some relationship to fibroadenosis (*see* Chapter 11). Indeed, women who suffer from the latter often relate their discomfort to the premenstrual phase.

Premenstrual mastalgia is probably restricted to ovular cycles and can be used as evidence of ovulation. As in all breast conditions, and because of unequal development and activity, it is not uncommon for the pain to be unilateral, or worse on one side than the other.

### Cause

Premenstrual mastalgia in severe form is mostly seen in patients with PMS or a background of nervous tension and cancerophobia. The enlargement and discomfort can be due to congestion and oedema of the interglandular connective tissues as well as to glandular activity promoted by hormone stimuli.

### Treatment

- The patient should be reassured, especially about the absence of cancer.
- The breasts should be well supported and the patient discouraged from handling them to see if tenderness or nodules are present.
- Premenstrual restriction of fluid and salt as for PMS is worthy of trial.
- Bromocriptine and progestogens such as dydrogesterone for 7-10 days premenstrually are sometimes of value.
- Other drugs used for treatment of PMS are sometimes helpful.

## RECURRENT (CYCLICAL) BUCCAL AND VULVAR ULCERATION

### Clinical Features

Recurrent buccal ulceration ('aphthous ulcers') is sometimes cyclical and related to menstruation, the ulcers developing during the middle of the cycle or during the premenstrual phase, and healing during and after menstruation. In the typical case, occurring in a woman during active reproductive life the ulcers disappear during pregnancy and lactation but return afterwards. There may be simultaneous ulceration of the vulva, lower vagina and anus; or genital ulceration can occur without oral lesions.

Aphthous ulcers of the mouth are common; on the vulva they are not uncommon. They may first appear in adolescence but rarely become really troublesome until early adult life.

In the majority of cases of alleged cyclical ulceration, the lesions have no relationship to menstruation and *are not cyclical*. They appear intermittently, last for a few days or weeks, and then slowly heal. The dissociation of this syndrome from menstruation is emphasised by the fact that it is seen in men as well as in women, though less commonly.

The lesions in the mouth and on the genitalia usually take the form of extremely painful small shallow ulcers which have a central yellow slough surrounded by a scarlet rim. These occur singly or in crops and are roughly circular with a diameter up to 1 cm in size. They represent the breakdown of an initial papule and, in appearance, are similar to herpetic ulcers (Figs 40.1A and B).

In the mouth the two forms of the disease are sometimes termed, 'minor' and 'major' aphthous ulcers. The lesions develop on the insides of the lips and cheeks, on the tongue, the floor of the buccal cavity and the fauces.

Recurrent oral and genital ulceration can be accompanied or followed by recurrent iridocyclitis to form *Behcet's syndrome*. The interval before the

appearance of iridocyclitis may be as long as 10 years. Rare additional manifestations of this syndrome are other skin lesions such as pyoderma, thrombophlebitis, joint pains, hepatomegaly, splenomegaly and degenerative changes in the central nervous system. The last, which appear late, are serious; they are mostly found in the midbrain, cerebellum and brainstem. Erythema nodosum is also a recognised association. Most of the manifestations of this syndrome appear to have vasculitis as a basis.

### Aetiology

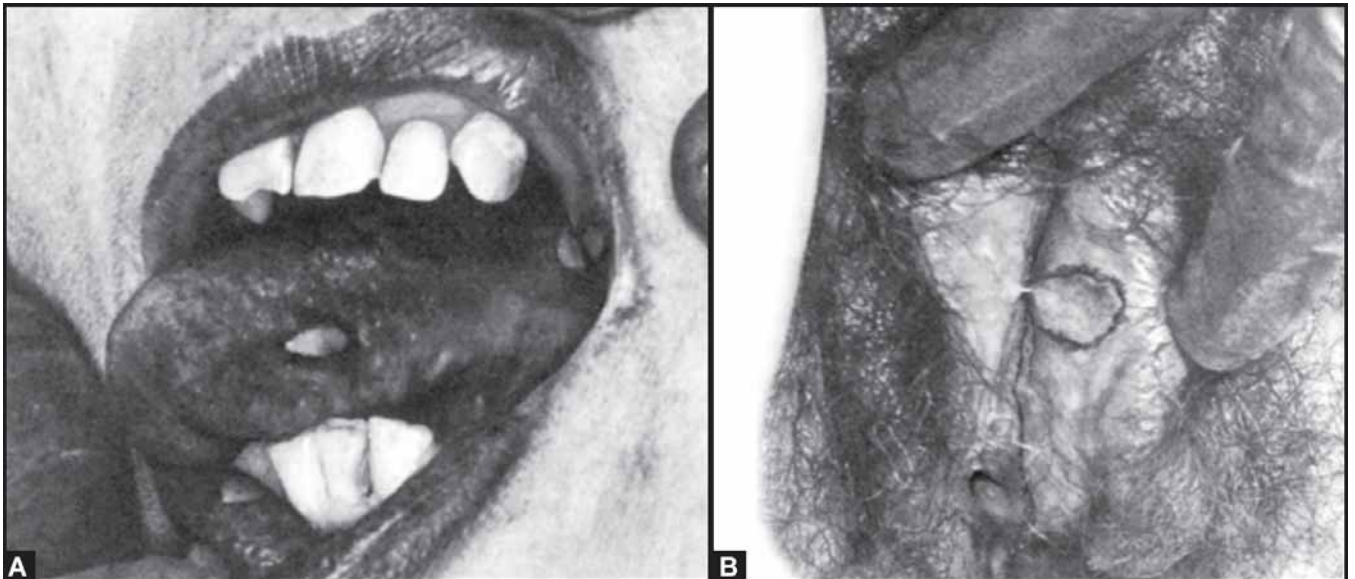
The cause of this extraordinarily trying condition is unknown but there are several theories postulated and certain aetiological factors established.

#### Genetic Factors

The operation of these is suggested by the fact that the disease can have a familial incidence. Genes encoding tumour necrosis factor have been implicated.

#### Allergy

A personal or family history of asthma, hay fever and other allergic states is often seen. Among the possible antigens are foodstuffs.



**Figs 40.1A and B:** Recurrent buccal and vulvar ulceration. In this case the lesions appeared simultaneously in the two sites and were mostly cyclical in that they developed premenstrually and commenced to heal during menstruation, (A) Two superficial ulcers can be seen on the tongue and one on each of the upper and lower lips, (B) An ulcer on the inner aspect of the left labium minus with a streak of pus running from it to the opposite labium. There is a second ulcer near the fourchette but this is not easily seen. (By permission of the Editors and Publishers of *Br Obstet Gynaecol Practise*)

An immunological disorder is also favoured by the finding of histiocytes, plasma cells and eosinophils in the tissues adjacent to the ulcer, and by the generally good response to treatment with corticosteroids and immunosuppressives.

#### *Virus Infection*

The herpetic appearance of one form of the ulceration raises this possibility but a specific virus has never been demonstrated.

#### *Hormonal Influences*

Some connection with sex hormones is suggested by the occasional relationship between ulceration and menstruation, and by its disappearance during pregnancy. It has been postulated that the various hormones can act as antigens but the evidence for this is lacking. The relationship to menstruation and pregnancy can have another explanation (*see below*).

#### *Psychological Factors*

These are the most important of all the known associations. Whatever other agents may be involved, a background of nervous stress, unhappiness, sexual misadventures and marital unhappiness is a frequent finding. An attack of ulceration is often precipitated by an emotional crisis and this can be clearly established in at least one-third of cases. For such reasons, the oral lesions were once (100 years ago) called 'neurotic ulcers of the mouth'.

The part played by the psyche and nervous stress could well explain the cyclical occurrence of ulceration premenstrually, when tension is at a height, and the disappearance of ulceration during pregnancy when most women are placid and content.

### Treatment

This is generally unsatisfactory only because it is empirical. Measures which have been and are used include the following:

- Attention to general health, mental as much as physical. This, together with correction of background factors and the giving of sympathetic psychological support, is more important than anything else in preventing relapses.
- Tranquillizers given regularly at night.

- Dental and oral hygiene.
- Local antiseptics and astringents. These include hydrogen peroxide mouthwashes and lotions, and applications of 1 per cent silver nitrate, salicylate gels, or tincture benzoin compound to the ulcers wherever they may be. They sometimes relieve local discomfort.
- *Hormones*: All the sex hormones have been tried and, if any are of value, it is oestrogens. These cornify the buccal mucosa and correct neutropenia. When given cyclically, preferably with progestogens, they sometimes appear to help.
- *Corticosteroids*: Given systemically these are of little value in preventing or curing the ulcers but, when applied locally as early as possible in an outbreak, they constitute the best available means of reducing tissue reaction, relieving pain and encouraging healing of the lesions. It is said that after several courses of treatment relapse is less common but this is certainly not always true.

For genital ulcers, regular applications of hydrocortisone ointment is best; for buccal ulcers pellets of hydrocortisone hemisuccinate sodium are held against them until the pellets dissolve. Tablets of 0.4 mg betamethasone are also given for sublingual absorption but these depress adrenal function.

- *Colchicine and azathioprine*: These have been used singly or in combination with corticosteroids.
- Newer therapeutic approaches include the use of cyclosporine, interferon, acyclovir, cyclophosphamide pulse therapy and thalidomide. Thalidomide has now been recognised as a potent anti-inflammatory drug but its teratogenicity necessitates the use of effective contraception when used in women in the childbearing age group.
- Antihistamine preparations, given orally or parenterally, rarely help.
- *Antibiotics*: These are generally useless except when applied locally to clear up secondarily infected ulcers.

### PELVIC ALLERGY

Allergic reactions described in relation to menstruation are herpetic eruptions on the lips, skin rashes, menstrual coryza, cyclical conjunctivitis and menstrual asthma. Some asthmatic subjects are especially liable to attacks premenstrually and these may not always be precipitated by nervous tension at the time. Oestrogens induce an attack in some subjects at any time, in others they are

curative. Cyclical conjunctivitis (*menstrual red eye*) may be related to menstrual coryza, in that swelling of the nasal mucosa in response to oestrogens could be a cause of both.

The treatment of the cyclically occurring allergic states is generally unsatisfactory. Some treat them as they would the PMS, others use tranquillizers, antihistamines and corticosteroids.

## VICARIOUS MENSTRUATION

### Clinical Features

This is a rare condition in which *extragenital* bleeding occurs at regular intervals corresponding to the menstrual period. If the bleeding replaces normal menstruation it is *substitutional*; this is reported to have occurred sometimes after hysterectomy with conservation of the ovaries. Usually extragenital bleeding accompanies a uterine flow and is *supplementary*. Vicarious menstruation occurs most often at the extremes of menstrual life and in individuals with nervous and vascular instability. It ceases with the menopause.

The commonest form of vicarious bleeding is epistaxis and this is a feature of at least 30 per cent of cases. Other sites affected are the alimentary tract, lungs, breasts, gums, lips, kidney, rectum, retina and conjunctiva. Older writers described 'bloody sweat' and 'bloody tears'.

### Cause

In many cases the bleeding is not exactly cyclical and a local lesion is ultimately found to account for it. Indeed, with increasing facilities for investigation, the diagnosis of vicarious menstruation is made much less frequently than in the past. Nevertheless, the phenomenon does occur and is the result of a vascular or cellular response of certain tissues to ovarian hormones. The epithelium over the inferior turbinate bones is readily influenced by oestrogen, hence the frequency of epistaxis. Extragenital endometriosis should always be considered as a possible basis. Cyclical haemoptysis, for example, can be a manifestation of pulmonary endometriosis.

### Treatment

A primary blood disorder and an organic lesion in the affected organ must be excluded as far as possible. When this has been done, no special treatment is necessary

unless the bleeding is heavy and uncontrollable. Accessible bleeding points, as in the nose, can be cauterised. Empirical remedies of unproven merit include calcium and vitamins C and K.

In very exceptional cases, as for example when retinal haemorrhages threaten sight, suppression of ovarian function may have to be considered.

## CYCLICAL HAEMOTHORAX AND PNEUMOTHORAX

### Cyclical Haemothorax

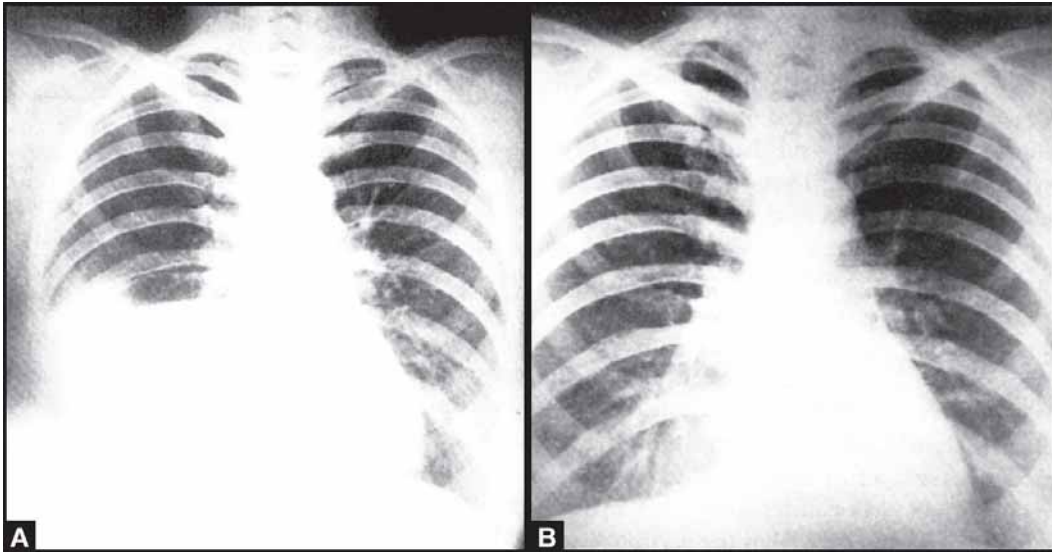
A rarity of great interest is the sudden development of haemothorax during menstruation, with resolution between each period (Figs 40.2A and B). This causes chest pain, faintness, respiratory embarrassment, pyrexia and constitutional upset – clinical features which gradually subside when the period is over. Although cyclical haemothorax can be suspected as being a form of vicarious menstruation, it is probably always a manifestation of endometriosis. Moreover, the haemothorax is invariably right-sided and is associated with pelvic endometriosis. It therefore seems likely that the blood does not arise from ectopic endometrium in the pleura but tracks from the abdominal cavity. Removal of pelvic endometriosis is followed by cure of the haemothorax. The right-sidedness probably has the same anatomical basis as has the hydrothorax seen in Meigs' syndrome.

Cyclical haemothorax can be controlled temporarily by suppressing menstruation with large doses of progestogen or danazol. Its cure rests on the treatment of the associated pelvic endometriosis. In this a radical approach of bilateral oophorectomy, rather than hormone therapy alone, is often required.

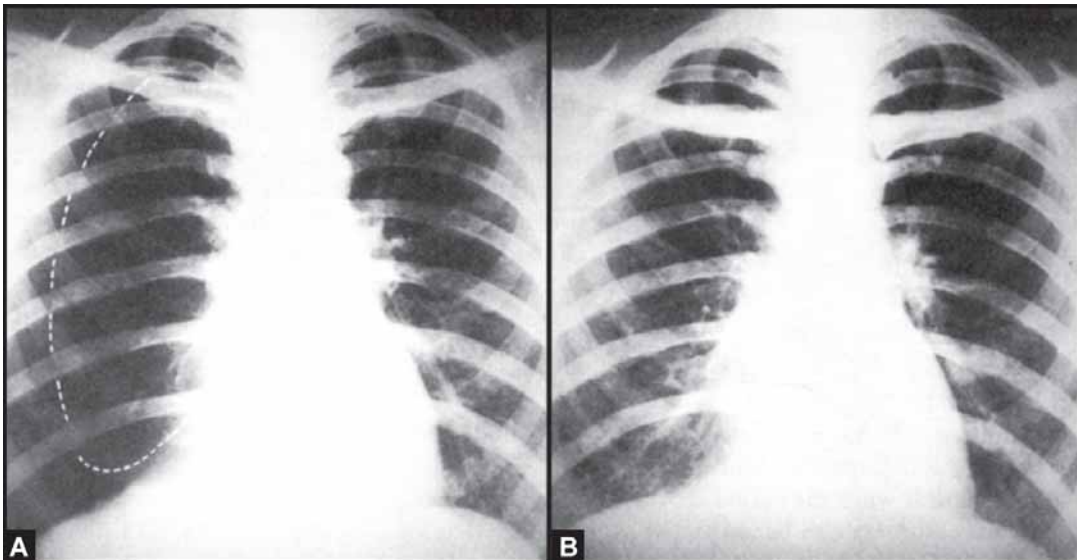
### Cyclical Pneumothorax

An even rarer and more mysterious condition is the sudden development of pneumothorax with collapse of the lung with each period. This resolves in the intermenstrual interval (Figs 40.3A and B). The patient complains of acute chest pain followed by dyspnoea at the onset of each menstrual period and the discomfort only subsides during the ensuing 14 days.

The explanation of this phenomenon is uncertain. Professor Jeffcoate reported one case in whom the pneumothorax was right-sided and occurred in every menstrual cycle during 13 months of observation. The



**Figs 40.2A and B:** Cyclical haemothorax. The patient in this case was aged 35 years and suffered an acute onset of right-sided haemothorax with each menstrual period for several months. She was found to have multiple uterine leiomyomas and widespread pelvic endometriosis. The occurrence of the haemothorax could be prevented by administering progestogens in doses large enough to suppress menstruation. The patient was ultimately treated by total hysterectomy with removal of both ovaries and the haemothorax did not recur thereafter, (A) Radiograph of the chest at the end of menstruation showing the opacity in the base of the right pleural cavity, (B) Radiograph taken in the intermenstrual phase when the blood was always reabsorbed



**Figs 40.3A and B:** Cyclical (menstrual) pneumothorax. In this case a right-sided pneumothorax developed spontaneously with each of 13 successive menstrual periods during which the patient was under observation, (A) Radiograph taken during a menstrual period showing collapse of the right lung (outlined in white) with air in the pleural cavity, (B) Radiograph taken during the intermenstrual phase showing complete re-expansion of the lung and normal appearances

patient was treated by thoracotomy (repeated) to obliterate the space between the two layers of pleura. She remained well and free from symptoms 10 years later.

In this case, rupture of emphysematous bullae was certainly not responsible for the recurrent pneumothorax (a theory which has been put forward). It is probably significant that in most of the other recorded cases, as in Professor Jeffcoate's, the pneumothorax was right-sided. This raises the possibility of air tracking from the peritoneal cavity through a defect in the diaphragm (*see* Meigs' syndrome), having gained access to the former via the genital tract at the onset of menstruation.

Unfortunately, in Professor Jeffcoate's case, radiographs never showed any evidence of pneumoperitoneum.

### MENSTRUAL EPILEPSY

#### Clinical Features

Less is heard of this condition now than in the past—when *hysterepilepsy* was recognised as a special form of epilepsy in which the uterus (or at least the activity of the pelvic organs) was said to be the cause. It mostly affected girls and young women and the fits were said to occur only at menstrual periods. It was even treated by hysterectomy and oophorectomy in the first quarter of this century.

It is now clear that classical idiopathic epilepsy often makes its first appearance at puberty and that its manifestations are much more likely about the time of menstruation and also at the mid-cycle coinciding with the oestrogen peak. Oestrogen has been shown to increase seizure activity in animals whereas progesterone decreases it. The correlation with menstruation may also be because phases of stress reveal an underlying predisposition. In nearly all cases of 'menstrual epilepsy' it will be found on careful inquiry that fits do occur occasionally apart from menstruation. In the very few cases where attacks occur *only* at the time of menstruation there is probably confusion between hysteria and petit mal.

#### Treatment

The treatment is that of epilepsy, although the premenstrual restriction of salt and fluid intake may make an attack during menstruation less likely.

Progesterone has a sedative effect on the central nervous system. Depot medroxyprogesterone acetate 150 mg administered every 1-2 months intramuscularly decreases the frequency of seizures by up to 50 per cent. High doses are needed because antiepileptic drugs cause induction of hepatic enzymes and enhance metabolic clearance. Therefore oral medroxyprogesterone acetate is not as effective.

# CHAPTER 41

## Hormone Therapy in Gynaecology

Oestrogens	637	Antiandrogens	650
Anti-oestrogens	644	Types of Gonadotrophins	650
Progestogens	644	Antigonadotrophins	652
Antiprogestogens	647	Hypothalamic Hormones	654
Androgens	647		

### OESTROGENS

An oestrogen is any substance having properties similar to oestradiol, the follicular hormone of the ovary.

#### Natural Oestrogens

Oestradiol, oestrone and oestriol are C-18 steroids synthesised in the ovary, adrenal cortex and placenta of women (*see* Chapters 3 and 7). They have in common an unsaturated A ring and a hydroxyl group at position 3, and are subject to considerable interconversion at their sites of production and in the liver. The liver is all-important to the metabolism and inactivation of these oestrogens.

Before excretion, oestradiol (the most potent of the three) is mostly converted to oestrone and oestriol, and these are found in the urine and faeces in the form of biologically inactive conjugates with glucuronide and sulphate groups. The many other metabolites identified in the urine are unimportant.

Oestriol is too feebly oestrogenic to be of significant therapeutic value. Medicinally, both oestradiol and oestrone are used, mainly in the form of benzoate, propionate, sulphate and other esters. Esterification makes them more efficient in that their absorption and action are more prolonged.

#### Synthetic Oestrogens

These fall into two groups: semisynthetic derivatives of oestradiol, such as ethinyl oestradiol and mestranol; and non-steroidal wholly synthetic preparations, such as diethylstilboestrol (Fig. 41.1).

Both groups of synthetic oestrogens are metabolised slowly and this makes them valuable therapeutically. Moreover, they are as effective when administered orally as by any other route.

#### Potency

Comparison of potencies is not easy or accurate because biological activity varies according to esterification, route of administration, spacing of doses and the vehicle used for the hormone.

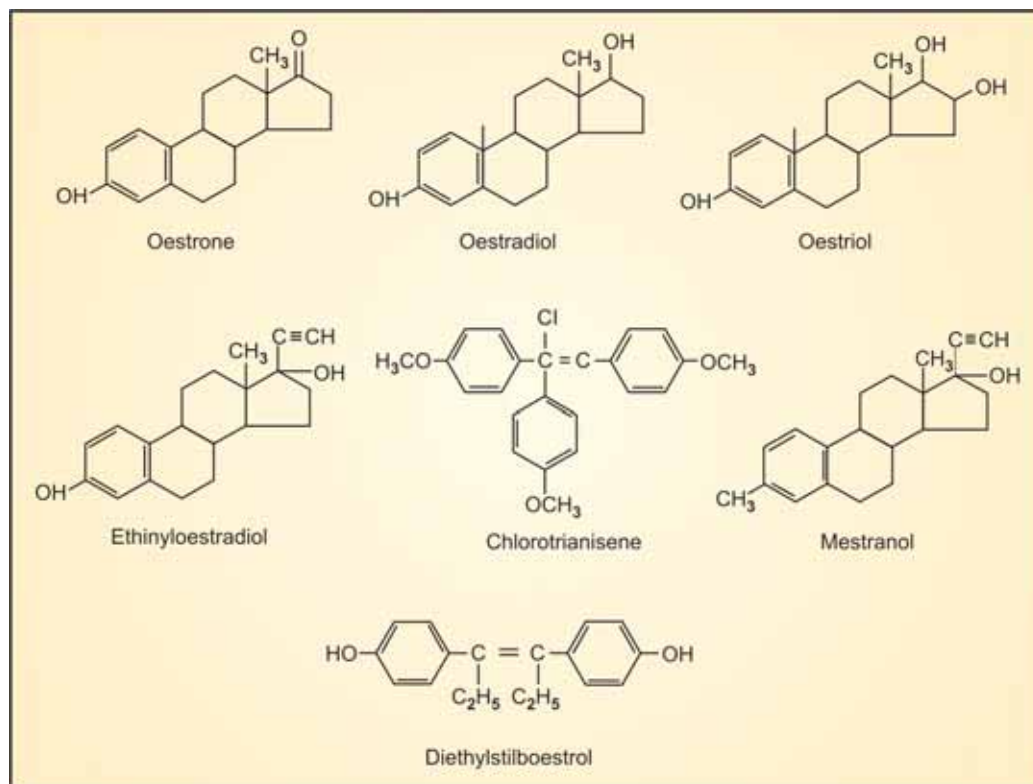


Fig. 41.1: The chemical structures of certain oestrogens

In practice, ethinyl oestradiol, is mainly used because it is highly potent by the oral route and cheap. When a weakly oestrogenic effect is required, as for the relief of menopausal symptoms, preparations of oestrone sulphate including conjugated equine oestrogens, can be given orally. Oestriol creams have been used vaginally.

All oestrogens act on all target organs. Differences in response are essentially due to the difference in their relative potency.

### Actions

The actions of all oestrogens are similar in principle and are described in Chapter 3.

### Therapeutic Applications

#### General Principles

- The effect of oestrogens is not seen immediately. Even if they are given intravenously no change is manifest in less than 12 hours, and a full effect requires continuous treatment for 4-5 days.

- The action of oestrogens is short-lived and begins to pass off within 24-48 hours of withdrawal.
- Oestrogens can be administered by mouth, by regularly spaced injections, or by establishing a reservoir in the body.
- The smallest possible dose should be used to achieve its objective. It is generally best to give oestrogens intermittently, 3 weeks on and 1 week off, thus simulating the natural production by the ovary and allowing the hypothalamus and pituitary periodic relief from their inhibitory effect.
- Oestrogens are valueless if the target organs are unresponsive.
- To avoid potential carcinogenic effects, all long-term therapy should be associated with the cyclical administration of a progestogen if the uterus is intact.

### Methods of Administration

#### Oral

Ethinyl oestradiol tablets are available in strengths of 20 µg, 50 µg, 500 µg, 1 mg and 2 mg. Oral formulations



are available in combination with norethindrone, levonorgestrel, norgestrel, desogestrel, gestodene and norgestimate for contraception. The strength of ethinyl oestradiol in these preparations varies from 20 to 50 µg. Ethinyl oestradiol is also available in combination with cyproterone acetate. Oestradiol valerate is available alone and in combination with levonorgestrel for hormone replacement therapy (HRT).

This route should be used if possible and is nearly always the best when synthetic preparations are given. Natural oestrogens are destroyed by gastric juices or are inactivated by the liver on absorption from the stomach, so they are only one-fifth as active by mouth as by injection.

### *Percutaneous*

Oestrogens are absorbed through the skin and can be given in the form of ointments to the vagina, vulva and other areas with the idea of concentrating their action locally and limiting their general effects. Proprietary preparations contain 3-5 per cent oestrogen and must be thoroughly rubbed in. Vaginal pessaries containing 25 mg oestradiol are also available and are used mainly for vaginitis. Some contain lactic acid in addition to one of the oestrogens. It is extremely doubtful, however, whether administering an oestrogen percutaneously or intravaginally does localise its action. In fact, oestradiol gels (0.06%) are available for transdermal application for HRT. Each measure contains 1.25 g of the gel and 750 mg of oestradiol. Two measures are the recommended as starting dose.

Self-adhesive patches of oestradiol are available in several countries for use in HRT. They can be applied on any part of the body except over the breasts and require to be changed twice a week. Oestradiol is released at the rate of 25, 50 or 100 µg per 24 hours. The standard dose is 50 µg. Combination patches with norethindrone acetate and dydrogesterone are available in some countries.

Vaginal rings made of silicone elastomer contain a drug reservoir of 2 mg oestradiol hemihydrate. Oestradiol is released at a rate of 7.5 µg per 24 hours for at least 90 days.

### *Implants and Depots*

Tablets containing 25, 50 and 100 mg of fused crystalline oestradiol are available for subcutaneous or subfascial implantation.

They produce a continuous but gradually waning effect for long periods (100 mg oestradiol is said to act for 2 years, but is very variable and usually much less long-lasting). In clinical practice 25-50 mg implants are inserted at 6-monthly intervals.

Although useful for certain conditions, they should *never* be used in women who have not had hysterectomy carried out. Their effect on the uterus cannot be foreseen and, if severe bleeding does result, it is usually impossible to find and remove the tablet. Cases are recorded where hysterectomy has had to be carried out for this complication.

### *Injectable*

Conjugated equine oestrogens in doses of 12.5 mg are available for use i.v. or i.m. They are useful for arresting the bleeding in patients with very severe uterine haemorrhage.

Long-acting oestrogens act for 2 to 4 weeks (oestradiol valerate 5-20 mg i.m., oestradiol cypionate 1-5 mg) or for as long as 8 weeks (oestradiol undecanoate 100 mg for carcinoma prostate).

Oestradiol benzoate and dipropionate are available in combination with testosterone esters but these should not be used.

### **Indications**

Oestrogens are administered for many conditions, which are summarised here.

#### *Vulvovaginitis of Infancy*

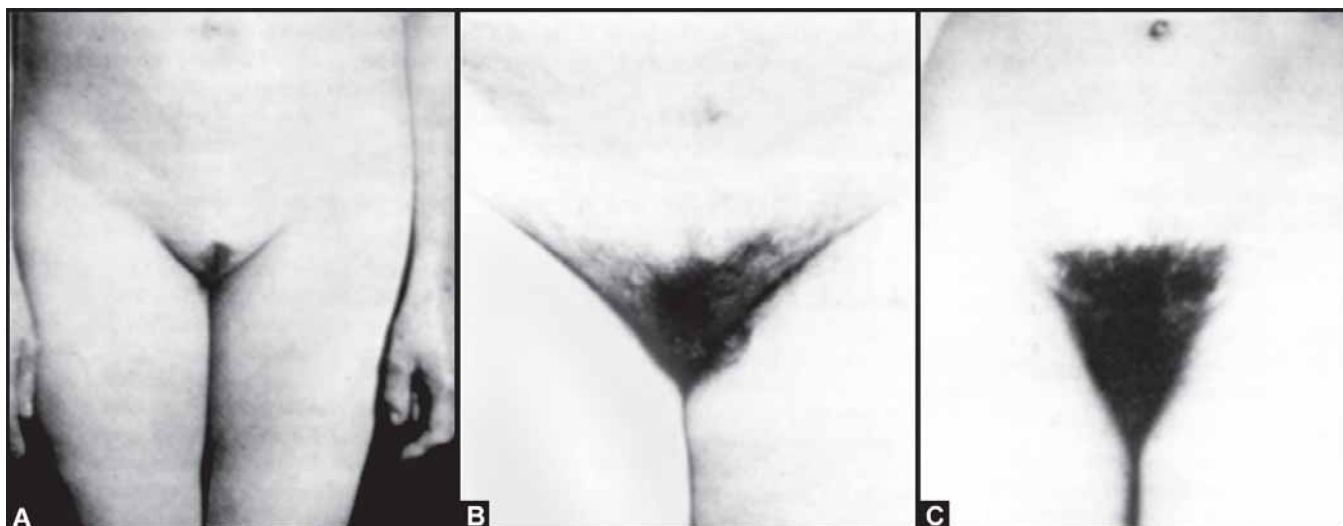
Described in Chapter 20.

#### *Secondary Sex Characters*

Oestrogens help in the development of female sex characteristics in girls with gonadal dysgenesis but certain features, such as axillary and pubic hair, require androgenic hormones, usually of adrenal origin, in addition (Figs 41.2A to C). They are of little value in counteracting the effects of androgens in women and do not lessen the growth of facial and body hair.

#### *To Decrease Excessive Growth*

Predicted excessive tall stature (more than 183 cm) in girls growing excessively at the age of 11-13 years with no organic pathology may be limited by administering 0.3 mg ethinyl oestradiol daily with norethindrone 10 mg daily for 5-7 days every 4 weeks. Treatment may



**Figs 41.2A to C:** These photographs illustrate that the growth of pubic hair is controlled by the adrenals rather than by the ovaries, and by androgens rather than by oestrogens. (A) A case of Sheehan's syndrome treated for several months with oestrogens without effect on the baldness of the pubes. (B) A similar case treated with methyltestosterone alone showing the resulting good growth of pubic hair. This, moreover, has a 'female' distribution despite the administration of an androgen. (C) The pubic hair remains luxuriant in a 44-year-old woman from whom both ovaries had been removed 5 years previously and who had not had any replacement therapy

require to be continued for 1-3 years. The 50 µg dose does not cause epiphyseal closure.

#### *Menopausal Symptoms and Changes*

Oestrogens relieve true climacteric symptoms, that is, those believed to be caused by an increased output of gonadotrophins or oestrogen deficiency. Short-term treatment is useful in the treatment of atrophic symptoms of the genitourinary tract (Figs 41.3A and B) and of vasomotor symptoms. On a long-term basis, they are of value for prevention of osteoporosis, apart from benefits on skin, body fat distribution, lipid profile and a possible benefit against coronary artery disease and Alzheimer's disease. If the uterus is present, and in certain special situations even after hysterectomy, they must be combined with a progestogen to prevent harmful effects.

#### *To Improve Healing*

Oestrogens are sometimes given 4-6 weeks before and after vaginal operations in the elderly to promote healing of senile tissues.

#### *Vulvar Epithelial Disorders*

Pruritus vulvae associated with these or other skin conditions is not benefited by oestrogen therapy of any

kind. But, in old women, scratch lesions with secondary infection are encouraged to heal (Figs 41.4A and B). In a lesion showing epithelial overactivity, oestrogens might, in theory at least, determine malignant change.

#### *Disorders of Ovulation and Menstruation*

*Amenorrhoea:* See Chapter 37.

*Dysfunctional uterine bleeding:* Oestrogens are used as endometrial haemostatics to arrest an episode of heavy or prolonged bleeding but are then combined with progestogen therapy from day 15 to build up a secretory endometrium.

*Dysmenorrhoea:* Oestrogens only relieve dysmenorrhoea when they are given in such a way as to suppress ovulation.

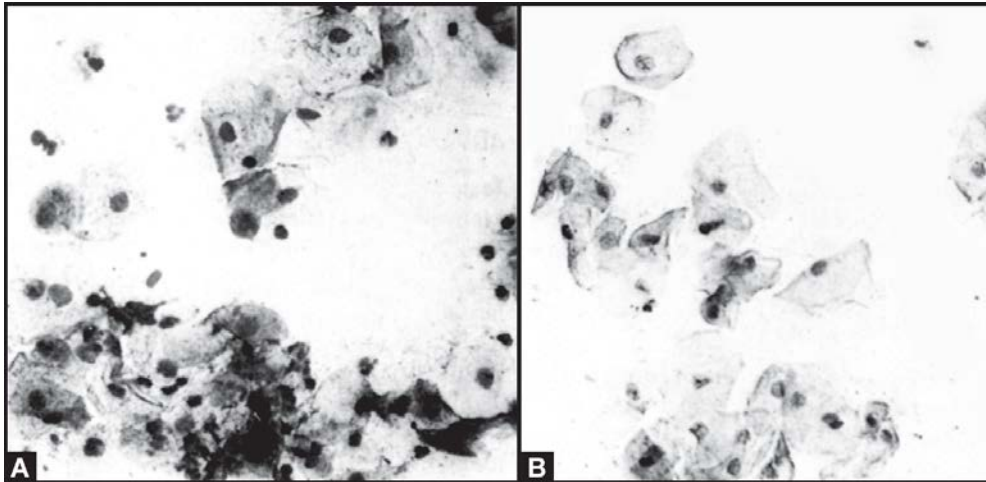
*Ovulation pain and bleeding:* See Chapter 39.

*Postponement or advancement of a menstrual period:* See Chapter 5.

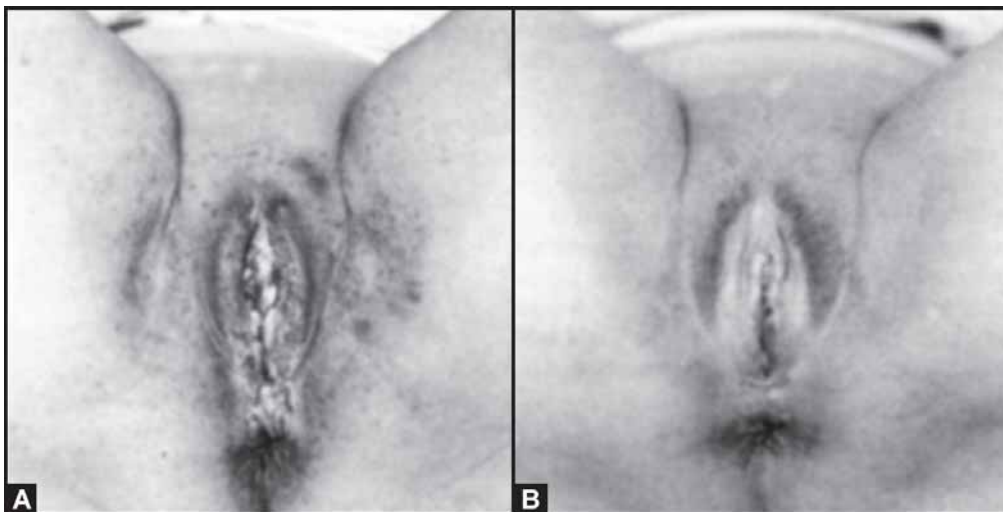
#### *Coitus and Conception*

*Frigidity:* Oestrogens only help in those cases where the condition is clearly caused by hypo-oestrogenism.

*Contraception:* Their antioviulatory property gives oestrogens a dominant place in oral contraception. But



**Figs 41.3A and B:** Senile vaginitis treated with oestrogen, (A) A vaginal smear from a 56-year-old woman suffering from vaginitis; it contains prekeratinised squames, pus cells and debris, (B) A smear obtained from the same patient 6 days later after she had taken a total of 50 mg stilboestrol; all evidence of infection has gone and healthy cornified squames now predominate. (By permission of the Editor, *BMJ*)



**Figs 41.4A and B:** A chronic vulvar epithelial disorder in a woman aged 72 years treated with oestrogens. (A) Before treatment, (B) After 2 months' treatment. Although the secondary infection has been eradicated, the oestrogen has had no good effect on the hyperkeratotic abnormality itself. (By permission of the Editor, *BMJ*)

they must be combined with a progestogen so that unwanted side-effects are counteracted.

**In pregnancy:** There is presently no role for oestrogens in pregnancy. As a clinical test for pregnancy, with or without progestogens, they are unreliable and harmful to the foetus. They are valueless for the induction of abortion and labour, even when the foetus is dead *in utero*; prostaglandins give better results.

### *Breast Conditions*

**Inhibition of lactation; relief of breast engorgement:** This is contraindicated because of the risk of thromboembolism.

**Development of the breast and nipples:** Oestrogens, given systemically, are useful provided that the breast tissues are sensitive to them. This is true for women and intersexes. The effect tends to be temporary so far as the

gland elements are concerned but, because of deposition of fat, the bust measurement does not reduce much when administration is discontinued.

### *Conditions in the Male*

The main indication is carcinoma of the prostate and its metastases. Oestrogens act mainly by depressing testicular function—by 'temporary hormone castration'.

### **Adverse Effects**

#### *Toxicity*

Many non-pregnant women cannot tolerate oestrogens and, except when very small doses are given, 20 per cent react by nausea, vomiting, weight gain, headache, dizziness and malaise. These side-effects usually subside within a few weeks or months if treatment is continued. They are less likely to occur with natural than with powerful synthetic oestrogens, their incidence being mostly determined by the biological activity of the preparation given.

#### *Metabolic*

Oestrogens tend to cause sodium and fluid retention and this can be accompanied by oedema, increase in weight and slight hypertension at the beginning of treatment. They raise the plasma levels of thyroxine-binding protein, corticosteroid-binding protein, sex hormone binding globulin, renin substrate and sometimes that of cholesterol. In certain women at least, they cause hyperlipidaemia.

Glucose tolerance is reduced, possibly more by mestranol than by ethinyl oestradiol.

As revealed by the most sensitive liver function tests, oestrogens alter the blood flow and function of the liver, but this is usually of little consequence. Susceptible women can, however, develop cholestatic jaundice. Impaired liver function always contraindicates oestrogen therapy.

#### *Inhibition of the Hypothalamus, Pituitary, Ovaries and Testes*

This results from continuous oestrogen administration. Stilboestrol, 1 mg daily, is enough to have this effect; 5 mg daily results in the disappearance of all demonstrable gonadotrophins in both men and women.

The comparable doses of ethinyl oestradiol are 30-50 µg and 200 µg.

Amenorrhoea *persisting* after suspension of treatment is a rare sequel to the inhibition.

#### *Genital Tract*

Oestrogens, unless counteracted by progestogens given simultaneously, cause endometrial hyperplasia at any age, even after the menopause and in childhood (*see* Figs 38.10 and 41.5A and B). This can result in irregular and heavy threshold or withdrawal haemorrhage. Uterine leiomyomas may increase in size. Cervical ectropion may develop or fail to resolve and there may be an increased tendency to vaginal candidiasis.

#### *Thromboembolism*

Oestrogens increase the coagulation Factors V, VIII, X and fibrinogen in the blood. However, the risk of superficial and deep venous thrombosis, pulmonary embolism and cerebral arterial thrombosis occurring is statistically very small, especially in younger women without other predisposing factors. However, women with decreased levels of protein C, protein S, anti-thrombin C and smokers are at a higher risk. It is rare for natural oestrogens to cause thromboembolism.

#### *Breasts*

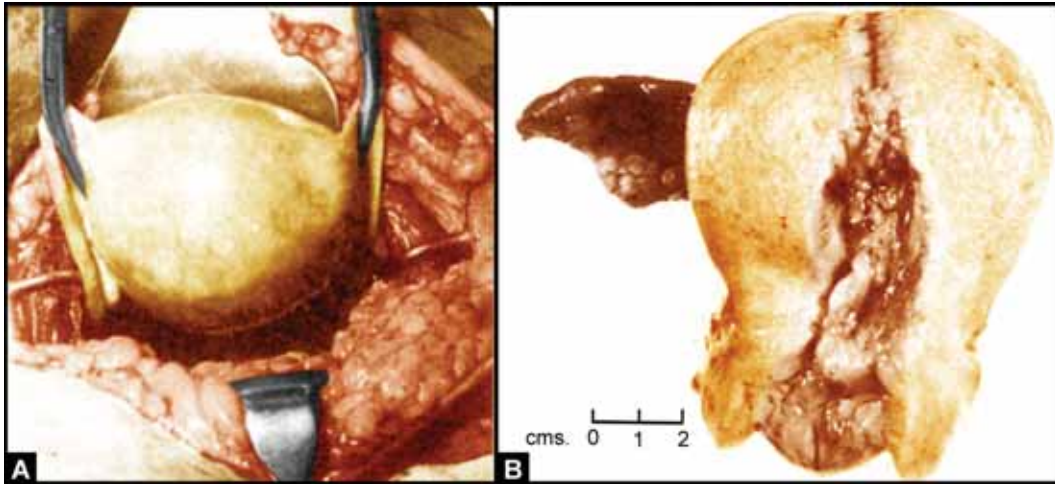
The breasts respond by enlargement, and may become painful and tender; this may be undesirable in children, old women and men. Areas of chronic mastitis react by forming cysts; an adenoma may increase in size.

#### *Skin*

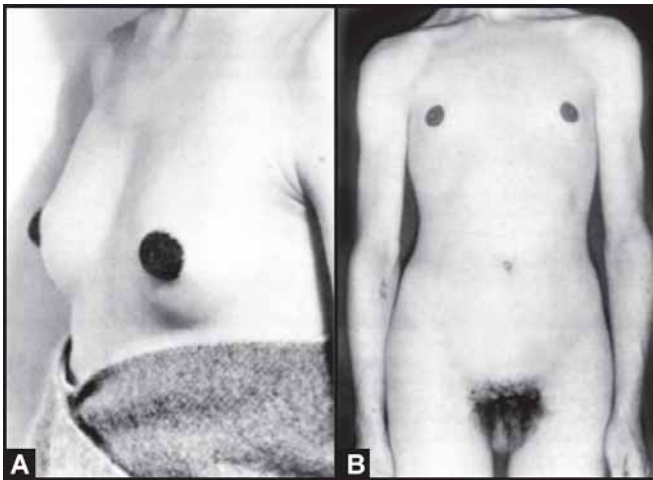
Pigmentation of the breast areolae and production of a linea nigra on the abdominal wall are common sequels to oestrogen therapy (Figs 41.6A and B). Chloasma is also not uncommon. The pigmentation fades in time but can take years to disappear completely. Haemorrhagic skin eruptions, erythema multiforme and erythema nodosum have been reported. Some women may have loss of scalp hair; rarely, hirsutism may develop.

#### *Libido*

Libido in men is decreased, but can be awakened or increased in young girls and old women, by oestrogen therapy.



**Figs 41.5A and B:** The effect of prolonged oestrogen therapy on the human uterus, (A) The uterus at laparotomy on a woman aged 56 years who had taken oestrogens for 3 years. It is symmetrically enlarged to the size of a 10-weeks pregnant uterus, (B) After removal the same uterus shows not only diffuse thickening of the myometrium but also endometrial cancer



**Figs 41.6A and B:** Pigmentation of the areolae and enlargement of the breasts caused by oestrogens. (A) The effect of 3 months' treatment with oestrogen in the case of a girl aged 20 years suffering from primary amenorrhoea and absence of breast development (cause not investigated), (B) A man aged 18 years who was given an oestrogen as the treatment of acne vulgaris. The breast areolae are almost black, although there is not much gynaecomastia.

### Cancer

Oestrogens are such powerful epithelial stimulants that there is reason to fear that they may encourage the development of cancer in their target organs—the breasts, uterus, vagina and vulva. Local applications have caused skin cancer in certain animals.

Oestrogens also favour the development of cancer of the breast in strains of mice which are ordinarily resistant to it. So far as the human being is concerned any carcinogenic effect is related to unopposed oestrogen therapy and endometrial carcinoma, and the knowledge that exposure of the *foetal* vagina to oestrogens can sometimes determine the occurrence of a clear cell carcinoma in adolescence.

### Miscellaneous

With high doses of oestrogens there may be changes in the corneal curvature leading to intolerance of contact lenses. Chloasma and cholestatic jaundice are rare adverse effects. Sick cell crisis, exacerbation of symptoms of porphyria and chorea have been reported.

### Contraindications

Oestrogen therapy is contraindicated in pregnancy, undiagnosed abnormal vaginal bleeding, in the presence of oestrogen-dependent cancers, e.g. those of the breast, endometrium and melanoma and in severe systemic lupus erythematosus. Previous endometrial hyperplasia, endometriosis, active liver disease, gallstones, leiomyomas, deep vein thrombosis, severe diabetes mellitus, hypertension, migraine and otosclerosis are relative contraindications.

## ANTI-OESTROGENS

A number of compounds appear to have a limited ability to inhibit the action of certain oestrogens but the concept of an anti-oestrogen is not simple. Antagonists may be short-acting, long-acting or physiological and may be pure or may have mixed agonistic-antagonistic actions.

Androgens can be considered anti-oestrogenic, but only because they act differently on the same target organs; this antagonism is physiological.

Some oestrogens have anti-oestrogenic properties; thus diethylstilboestrol can prevent the effects which other oestrogens have on the rodent vagina. Oestriol competes with oestradiol for nuclear receptors in short-acting antagonism, therefore short-term responses are obtained but not long-term.

The two anti-oestrogens which have so far attracted most attention are clomiphene and tamoxifen which are mixed oestrogen agonists-antagonists of the long-acting variety. Clomiphene, a member of the triphenylethylene series, is a derivative of chlorotrianisene which is itself an oestrogen. Tamoxifen is also a member of the triphenylethylene series. The endometrium is sensitive to the agonistic response, whereas the breast is more sensitive to the antagonistic behaviour due to the differences in type of oestrogen receptor at the two sites. The antagonistic response is essentially mediated through the depletion of hormone receptors consequent to nuclear receptor binding. Both clomiphene and tamoxifen are powerful stimulants of ovulation in selected cases.

Tamoxifen, 20 mg per day, is the adjuvant treatment of choice for breast cancer and has been shown to prolong disease-free survival. Best results are achieved in oestrogen receptor-positive tumours, but it is also effective in oestrogen receptor-negative tumours through cellular mechanisms in breast cells, fibroblasts and stromal cells. In any case, the oestrogen receptor status of breast tumours is known to change over a period of time. Currently, tamoxifen use is limited to a period of 5 years. Long-term use has been shown to be associated with endometrial agonist adverse effects, i.e. endometrial hyperplasia, endometrial polyps, endometrial cancer and flare-up of endometriosis. It has a positive action on bone in postmenopausal women, though less than oestrogen or bisphosphonates, but causes bone loss in premenopausal women. Other adverse effects include hot flushes, vaginal changes, irregular menstruation and thromboembolism. Other tri-phenylethylene derivatives

being studied for use in breast cancer include droloxifene, idoxifene and toremifene.

Raloxifene is a benzothiophene derivative which is also a mixed oestrogen agonist-antagonist with selective oestrogen receptor modulator (SERM) properties. It has minimal uterotopic properties; in the breast it has a beneficial or neutral profile; it has beneficial effects on bones and lipids. In the bone it inhibits IL-6 stimulated differentiation of osteoclasts and thus prevents osteoporosis. It is a promising agent for HRT. T-588 is an agent from this group which may be useful in the prevention of Alzheimer's disease.

The benzopyran centchroman is also a SERM. Originally developed in India as a non-steroidal oral contraceptive, it was initially proposed as a once-a-week pill but this was associated with unacceptable failure rates. The dose was therefore revised to twice-weekly for the first three months, followed by weekly doses. It has also been tried for postcoital contraception. It inhibits osteoclast activity.

Phytoestrogens are plant-derived chemicals with oestrogenic and anti-oestrogenic activity. They inhibit the enzymatic conversion of endogenous oestrone to oestradiol and also possess intrinsic oestrogen activity. The isoflavones have the greatest potency; along with genisterin and daidzein these are found in soy-based diets. Ginseng has also been found to have oestrogenic, anti-oestrogenic and androgenic properties.

Pure anti-oestrogens are being developed which are derivatives of oestradiol with long hydrophobic side-chains. These have been termed ICI164, 384 and ICI 182, 780. They inhibit breast cancer cells and cause uterine involution. They may be useful in women with tamoxifen-resistant tumours. The whole field of anti-oestrogens is being actively explored.

## PROGESTOGENS

### Types and Sources

A progestogen is a substance which produces progestational changes in an oestrogen-primed endometrium. Not all the synthetic progesterone substitutes are strongly active in this respect and few simulate progesterone in *all* its effects. For example, their thermogenic, androgenic, oestrogenic and other biological properties, such as the maintenance of pregnancy in animals and the support of the endometrium in women, vary widely from one to another.

### Natural Progestogens

The natural product is progesterone. This is a steroid, derived from cholesterol via  $17\alpha$ -hydroxyprogesterone, and secreted by the corpus luteum, placenta and the adrenal cortex. In the last site progesterone is an intermediate product in the formation of cortisol. In both the adrenal cortex and the ovary, progesterone can be converted to androgens and oestrogens (*see* Chapters 3 and 7).

Progesterone is rapidly metabolised by the liver and approximately 20 per cent is excreted in the urine as sodium pregnanediol glucuronide. The fate of the remainder is uncertain.

### Synthetic Progestogens

For therapeutic purposes, progesterone is generally prepared synthetically. The synthetic progesterone substitutes which are best known and are in common usage are as follows.

- *Progesterone derivatives* such as  $17\alpha$ -hydroxyprogesterone caproate, medroxyprogesterone acetate, megestrol acetate and chlormadinone acetate.
- *Stereoisomers of progesterone* such as dydrogesterone.
- *Testosterone derivatives* such as ethisterone and dimethisterone.
- *19-norsteroids* (nortestosterone derivatives) such as norethisterone, norethisterone acetate, norethynodrel, allyloestrenol, ethynodiol diacetate and the 'newer' progestogens — desogestrel, gestodene and norgestimate — which are 'lipid-friendly'.

Norgestrel is often included in this group but, although closely related, is not strictly a steroid. It is the strongest of known progestogens, except cyproterone, but this is mainly used as an anti-androgen (*see below*).

Of the above, dydrogesterone and norethisterone, at least, are non-thermogenic; the testosterone and 19-nortestosterone derivatives are slightly androgenic. However, little is known about the metabolism of these progestogens. In some cases it may resemble that of testosterone but dydrogesterone, allyl-oestrenol, norethisterone (acetate) and norethynodrel are in part metabolised to ethinyl oestradiol in the body to have mildly oestrogenic effects. The status of ethynodiol acetate is uncertain. None is excreted as pregnanediol.

### Actions

The actions of progesterone are described in Chapter 3. Those of the oral progestogens are basically similar but,

as already noted, vary in detail and emphasis. This, as well as different methods of administration and of assessment, makes it impossible to compare relative potencies.

## Therapeutic Applications

### General Principles

- Progestogens, like oestrogens, take several days to produce their maximum tissue effects, although certain responses, such as a rise in temperature, occur within a few hours of their administration.
- The action of progestogens is short lived and begins to subside within 24-48 hours of suspending treatment.
- Divided and regularly spaced doses, or continuous absorption from a depot, are necessary for efficient use. This is especially true of progesterone itself which, in the blood, has a half-life of only a few minutes.
- Progestogens are ineffective unless the target organ is previously or simultaneously primed with oestrogen.

### Methods of Administration

Progesterone itself is ineffective by mouth except in the newer micronised preparation which is available as 100 mg tablets to be used orally or vaginally. It may be administered by deep intramuscular injections containing 25-50 mg/ml.

Suppositories, each containing 25 mg progesterone, are available for inserting into the vagina or rectum. In some countries, progesterone is available in a gel which adheres to the vaginal mucosa. Progestasert IUCD contains progesterone; levonorgestrel is available in an IUCD as well as in subdermal implants (Norplant) and intravaginal rings.

All the progesterone substitutes except  $17\alpha$ -hydroxyprogesterone caproate are usually given orally. The details of dosage are given in the appropriate chapters.

## Indications

### Disorders of Menstruation and Ovulation

*Amenorrhoea:* Progestogens may be given alone for secondary amenorrhoea but are usually combined with oestrogen. In primary amenorrhoea, priming with oestrogen is essential.

**Dysfunctional uterine bleeding:** Although used for all types of dysfunctional bleeding, progestogens are chiefly indicated for anovulatory bleeding and correction of endometrial hyperplasia.

**Spasmodic dysmenorrhoea:** Progestogens relieve true dysmenorrhoea when they are combined with oestrogen and given in such a way as to inhibit ovulation. Progestogens alone also decrease production of PGF<sub>2α</sub> and vasopressin and relieve primary dysmenorrhoea.

**Premenstrual syndrome:** Progestogens are widely used for this and allied conditions but their value is debated.

**Postponement or advancement of a menstrual period:** See Chapter 5.

### Conception and Pregnancy

**Contraception:** Mainly because they make cervical mucus hostile to spermatozoa and the endometrium unreceptive to a fertilised ovum, progestogens, with or without oestrogens, are valuable contraceptives. They can also inhibit ovulation.

**Infertility:** Progesterone is used in cases of luteal phase defect in the secretory phase of the cycle. The empirical use of progesterone in the postovulatory phase to assist the implantation of a hypothetical early pregnancy is without proven merit. However, they have been used successfully in assisted reproduction techniques to establish a secretory endometrium.

**Threatened and recurrent abortion:** Here again progestogens are used, sometimes empirically, sometimes when a low level of progesterone suggests deficiency. Their value remains unproven by controlled observations when used empirically. However in cases of proven deficiency, progesterone therapy improves pregnancy outcome. However, the possibility of producing virilising effects in the foetus has thrown this treatment into disrepute. There are also reports that female foetuses exposed to progestogens *in utero* may exhibit a 'tomboyish' behaviour.

### Endometriosis

For this condition progestogens, alone or in conjunction with oestrogens, are given continuously in large doses to produce a state of pseudopregnancy. Treatment is continuous for 6-12 months.

### Hormone Replacement Therapy

In postmenopausal women with an intact uterus, the administration of oestrogen for climacteric symptoms or long-term benefit must be accompanied by the administration of progestogens to prevent the development of endometrial hyperplasia and cancer. In some cases the administration of progestogens is recommended even in hysterectomised women. The addition of 19-norsteroids to oestrogen may also potentiate its effect in correcting osteoporosis.

### Pelvic Cancer

Probably because they lead to glandular exhaustion, progestogens in large doses have an arresting effect on endometrial carcinoma and its metastases and are valuable adjuncts to surgery for this condition, especially for recurrent disease.

They are also used, with less certain action, for adenocarcinoma of the vagina, tube and ovary, and for other types of malignant disease of the uterine corpus. They do not appear to influence squamous cell carcinoma of the cervix and lower genital tract.

### Breast Conditions

Progestogens are sometimes recommended for fibrocystic disease and premenstrual mastalgia when other measures have failed.

### Adverse Effects

#### Toxicity

Progesterone itself rarely has any immediate side-effects except to cause a slight rise in body temperature. The synthetic oral progestogens, being more potent in some respects and longer acting, can produce systemic upsets such as nausea, vomiting, headache, depression, lassitude and pyrexia. The nausea is likened by the patient to that of pregnancy. Oral micronised progesterone causes somnolence and other central nervous system effects.

Jaundice is described as a complication of giving nortestosterone and testosterone derivatives but is very rare. These and other 19-norsteroids can, like oestrogens, modify hepatic handling of normal metabolic products and may reflect a competitive effect for a common excretory pathway.



### *Uterus*

Progestogens, especially when combined with a small dose of oestrogen, cause generalised enlargement of the uterus by myometrial hyperplasia and hypertrophy. They can also result in a rapid increase in the size of leiomyomas, possibly due to degenerative changes.

### *Menstrual Disturbance*

Progestogen-only pills do not regulate the cycle as well as combined pills. They cause irregular bleeding and they may result in scanty menstruation and amenorrhoea.

### *Breasts*

These respond by enlargement, increased vascularity, pain and tenderness.

### *Libido; coitus*

Progestogens tend to decrease libido, inspissate cervical mucus and make the vagina drier.

### *Virilism*

Progesterone itself is very mildly androgenic but many of the synthetic preparations are more so. This probably does not apply to  $17\alpha$ -hydroxyprogesterone, dydrogesterone and those which are partly converted to an oestrogen.

With any preparation the virilism induced amounts to no more than acne, a greasy scalp and slight facial hirsutism. However, if given in large doses during pregnancy, all except progesterone and its derivatives can masculinise the external genitalia of the female foetus.

### *Hypertension*

The hypertension which occasionally follows administration of the combined pill is mainly an oestrogen effect but there are reports suggesting that levonorgestrel can raise the blood pressure.

### *Thromboembolism*

When this complicates the taking of antioviulatory oral contraceptives it is mostly attributable to oestrogen. But progestogens cannot be completely exonerated.

### *Metabolism*

Most progestogens are mildly anabolic. When they cause an increase in weight it is probably by way of increasing the appetite, which is comparable to a pregnancy reaction. Indeed, progestogens induce a state of pseudopregnancy.

## ANTIPROGESTOGENS

RU 486 (mifepristone) and ZK 98299 (onapristone) are antiprogestins. RU 486 is a  $19\text{-nortestosterone}$  derivative with a dimethyl side chain at C-11 which gives it its antiprogestogen action. It has a very strong binding affinity for the progesterone receptor. It has some agonistic effect but the main effect is antagonistic and it has proved to be an efficient and convenient abortifacient used in combination with prostaglandins in the first trimester. It is also used in emergency contraception. Its role in contraception, induction of labour, etc. is still to be fully elucidated. RU486 binds to the glucocorticoid receptor and may be useful in the treatment of Cushing's syndrome.

Antiprogestogens in combination with an anti-oestrogen may be of benefit in progesterone receptor-positive breast cancer. Progesterone receptors have been found in the meninges and mifepristone has been used in the management of unresectable meningiomas.

Org 31710 and Org 31806 are newer antiprogestogens under trial. The most potent is Org 33628 with potent abortifacient, antitumour and ovulation suppressant effects.

## ANDROGENS

### Types and Sources

An androgen is a substance having the capacity to produce masculinity. There are many of these, some occurring naturally and some produced artificially. All tend to be anabolics as well as sex determinants and there is a tendency to group them according to the dominant action.

### *Natural Androgens*

Several of these are produced in the female as well as in the male. They vary in their androgenic potential and, from this standpoint, testosterone is the one of major

importance. In the blood it is bound to a specific protein and in its target tissues its effect is probably mediated by an even more active substance — dihydrotestosterone, the conversion taking place in the target organ.

Testosterone is metabolised in the liver extremely rapidly, being degraded mainly to aetiocholanolone and androsterone; these are excreted in the urine in the form of their glucuronide and sulphate esters.

In the male, testosterone is secreted mainly by the interstitial cells of the testis under the influence of LH, but a little is formed in the zona reticularis of the adrenal cortex. Other weak androgens such as androstenedione and dehydroepiandrosterone are also produced in both these sites, these as well as testosterone being synthesised from progesterone.

In the female, identical androgens are produced in the adrenal cortex and, in amounts relatively very small as compared with the testis, by the ovary.

The only naturally occurring androgen employed therapeutically is testosterone. It is administered intramuscularly. For sustained response it is administered in the form of a subfascial tablet implant, manufactured synthetically.

### *Synthetic Androgens*

Synthetic preparations with a mainly androgenic action are almost all derivatives of testosterone. They include its propionate and oenanthate esters for parenteral use, and methyltestosterone, fluoxymesterone and mesterolone (derived from dihydrotestosterone) for oral and sublingual administration.

Preparations which are only weakly androgenic and anabolic include the synthetic progestogens.

Those which are mainly anabolic include methyl androstenediol, oxymetholone, methyl androstano-lone and norethandrolone. Although these are alleged to be free from masculinising actions in women, their use is sometimes followed by hirsutism and voice changes.

Little is known about the metabolism of any of the synthetic androgens and androgenic anabolics.

### **Biological Actions**

#### *Metabolic Effects in Both Sexes*

Androgens conserve nitrogen and assist in the build-up of proteins. They also favour potassium, phosphorus and sulphur retention and for these reasons are important to

the development of muscle and the growth of bone. They therefore bring about an increase in weight, promote muscular strength and energy, and give a sensation of well-being. Androgens accelerate epiphyseal closure and ultimately limit stature; they also cause retention of sodium, chloride and fluid.

### **Actions in The Male**

The effects of androgens in the male are comparable to those of oestrogens in the female. They are responsible for the development and maintenance of secondary sex organs such as the penis, prostate, vasa, seminal vesicles and characters such as hair on the face, limbs and trunk, baldness, masculine figure, deep voice, and axillary sweating. Like oestrogens in the female they are not too important for sex drive.

Testosterone may play a direct role in spermatogenesis but testosterone in physiological amounts does *not* inhibit the gonadotrophic activity of the pituitary; otherwise men would be sterile or only cyclically fertile. Any depressant effect on the hypothalamic-pituitary system and the testes requires massive and continuous dosage. Androgens can cause prostatic hypertrophy and, surprisingly, occasionally result in gynaecomastia in youths. The latter effect probably arises when the hormone administered is metabolised into an oestrogen.

### **Actions in The Female**

#### *Sex Organs*

*Atrophy of the tubes, vagina, vulva and breasts:* Androgens directly depress the activity of all the tissues of the female genital tract and induce atrophy and secretory quiescence of the lining epithelia. The breasts shrink, cervical secretion dries up and menstruation ceases. In the embryo, androgens interfere with the development of the external genitalia, encourage persistence of the wolffian ducts and their derivatives, and thus cause a state of intersex in the female.

*Suppression of uterine and tubal contractions:* These decrease both in frequency and in amplitude.

*Ovaries:* The ovarian cycle is arrested and ovulation and menstruation cease. This is a direct effect rather than one exerted through the hypothalamic-pituitary system. As in the male, only massive doses can possibly inhibit that system.

### Secondary Sex Characters

Androgens are *normally* responsible for certain female sex characters — notably the axillary and pubic hair, axillary sweating and the activity of apocrine glands.

### Therapeutic Applications

#### Methods of Administration

**Intramuscular injection:** This is the route by which the *esters* of testosterone are administered. Their vehicle is oily so they create depots which are effective for 7-10 days. The usual dose of the chosen preparation is of the order of 5-25 mg once weekly.

**Orally (sublingually):** Methyltestosterone, fluoxymesterone and anabolic androgens are available in 5 mg and 10 mg pellets; these have a maximum effect if they are allowed to dissolve in the mouth. If they are swallowed their action is restricted by the detoxicating action of the liver.

Mesterolone is dispensed in 25 mg tablets. For oral substitution therapy in the male, the dose is 75-100 mg daily for a few months followed by a maintenance dose of 50 mg daily.

#### Implants

Pellets of 100 mg testosterone are available for subcutaneous or subfascial implant but have largely been abandoned. They were employed for the purpose of substitution therapy in the male and are never to be used in the female.

#### Indications

##### **In the female**

Presently, there is very little place for androgen therapy in the female. Androgens have now largely been replaced by synthetic progestogens.

**Dysfunctional uterine bleeding:** Androgens can control excessive uterine bleeding by decreasing the blood supply to the uterus, by causing it and its endometrium to atrophy, and by depressing ovarian function. But progestogens, with or without oestrogens, are better and safer uterine haemostatics.

**Premenstrual mastalgia and fibroadenosis:** Small doses of androgens given premenstrually may suppress breast activity and limit discomfort, but they are rarely indicated.

**Vulvar epithelial disorders:** The symptoms of pruritus vulvae which occur in some cases of benign vulvar epithelial change are sometimes completely relieved by local applications of methyltestosterone solution or testosterone propionate in arachis oil. It is difficult to explain how and why this gives symptomatic relief but it does.

##### **Uterine Leiomyomas**

The menorrhagia of leiomyomas can sometimes be controlled temporarily by androgens if, for some reason, the operation has to be postponed but, again, progestogens are to be preferred for such a purpose. Androgens do not cause leiomyomas to atrophy.

**Endometriosis:** Androgens suppress the activity of ectopic endometrium and control the pain and bleeding associated with endometriosis. In order to produce some improvement in symptoms the dose does not necessarily have to be large enough to suppress ovulation and menstruation. The effect is temporary and the endometriosis usually becomes active again when treatment is suspended.

**Sexual unresponsiveness:** Small doses of methyltestosterone appear sometimes to increase heterosexual libido in women and are alleged to intensify orgasm. The action of androgen in this respect is not understood but it is suggested that it promotes a feeling of well-being, increases susceptibility to psychic stimuli and makes the genitalia more sensitive. Tibolone produces this effect through its androgenic metabolites.

**Metabolic errors:** The less virilising androgens can be used for their anabolic effects in circumstances such as the following:

- Emaciation associated with anorexia nervosa and chronic illnesses of any kind.
- To speed recovery after surgery and accidents.
- Delayed physical growth in children and adolescents in constitutional delayed puberty.
- States of adrenal failure.
- Acute and chronic renal failure.
- They are often employed, unethically, by women (and men) athletes who engage in lifting and throwing events, to increase their muscular strength.

##### **In the male**

When the endocrine function of the testes is definitely subnormal, androgen can be used to develop secondary male characters and to relieve frigidity. Impotence in the

male *with normal testes*, however, never responds to androgen therapy unless the effect is psychological. Androgens may be of help in the treatment of gynaecomastia.

The anabolic androgens can be indicated for their metabolic effects in the circumstances listed for the female above.

### Adverse Effects in The Female

#### Toxicity

Cholestatic jaundice occasionally complicates the use of androgens with an alkyl group substituted at position 17, e.g. methyltestosterone and is an indication for discontinuing treatment immediately. The jaundice is dose-related and reversible.

#### Fluid Retention

Oedema, swelling of the joints and other manifestations of electrolyte upset are sometimes seen during treatment.

#### Epiphyseal Closure

Testosterone and its derivatives not only encourage physical growth in the young, they limit it by promoting epiphyseal closure. How far this applies to the synthetic, mainly anabolic androgens, is uncertain.

#### Virilism

Large doses of androgens nearly always induce virilism; small doses can do so in susceptible women. Tolerance to androgens generally increases after the age of 40 years but, before that time, varies enormously from one individual to another.

The common virilising effects of androgen therapy are deepening of the voice; acne; growth of hair on the face; increased muscular development with a decrease in subcutaneous fat; atrophy of the breasts; loss of frontal hair; and enlargement of the clitoris. The last two, and deepening of the voice, are usually permanent; but the others are reversible and disappear or become less obvious when treatment is suspended.

These adverse effects are clearly undesirable and make the following guiding rules necessary:

- Never prescribe androgens for a woman without first informing the patient of the possible adverse effects.
- Do not use androgens in women especially under the age of 40 years unless there is a very strong indication.

### ANTIANDROGENS

Cyproterone acetate is a very powerful antiandrogen and it seems that its antiandrogenic effects are reversible. In doses of 50 mg twice daily, it is used in the treatment of severe hypersexuality and sexual deviation in the male, as it inhibits spermatogenesis and produces reversible infertility. Consideration must be given to the risks and benefits, as hepatic tumours have been produced in animals using large doses.

Cyproterone, 2 mg, with ethinyl oestradiol, 50 µg, has been used for the treatment of severe acne refractory to other therapy. Some women with mild to moderate idiopathic hirsutism and polycystic ovary syndrome (PCOS) may benefit, as hair growth is also androgen-dependent. Cyproterone with ethinyl oestradiol is also an effective contraceptive measure for these women or for women with androgen-dependent skin conditions.

Spironolactone similarly binds to the androgen receptor and exerts mixed agonism—antagonism but in hyperandrogenic states only the antagonistic effect is seen.

Flutamide, a non-steroidal pure antiandrogen has been developed. Finasteride, a 5 $\alpha$ -reductase inhibitor, is under clinical evaluation.

### TYPES OF GONADOTROPHINS

#### Pituitary Gonadotrophins

The gonadotrophins secreted by the pituitary under the influence of the hypothalamus are described in Chapter 3.

Pituitary gonadotrophins were initially extracted from lyophilised human glands removed at autopsy, the products being termed human placental gonadotrophin (hPG), but 10 glands are required to obtain enough material to induce one ovulatory cycle in a woman. Moreover, these preparations carry the risk of contamination with the Creutzfeldt-Jacob virus.

Pituitary gonadotrophins presently available for use (human menopausal gonadotrophin, hMG) are extracted from the urine of postmenopausal women. Preparations from this source contain both follicle stimulating hormone (FSH) and luteinising hormone (LH). Their potencies may vary from one batch to another but usually contain 75 IU of each.

Preparations of pure FSH isolated from urine are also available (urofollitropin or uFSH) which are especially useful in the induction of ovulation in those women who

have elevated levels of endogenous LH, as is seen in cases of PCOS.

### Chorionic Gonadotrophins

Chorionic gonadotrophins are similar, but not identical, to LH in chemical structure and action. They are complex glycoproteins found in the placenta, blood and urine of women throughout pregnancy. Their overall action is a luteinising one. Commercial preparations are made from the urine of pregnant women or from placentas.

### Recombinant Gonadotrophins

Recombinant technology has been used to clone genes for both the alpha and beta subunits of human FSH and transfect these into Chinese Hamster Ovary (CHO) cells. A CHO clone has been isolated that is capable of secreting intact glycosylated FSH (Follitropin) which is further purified by immunochromatography to yield an amino acid combination and sequence identical to natural FSH.

Recombinant LH and hCG have also been developed. The recombinant gonadotrophins have the advantage of higher purity and specific activity, batch-to-batch consistency and complete absence of contamination by other gonadotrophins. Their pharmacokinetics are very similar to the natural gonadotrophins.

### Therapeutic Applications

All gonadotrophins are standardised in international units, by comparison of their biological activities with that of standard reference preparations. They are unstable in solution, and are quickly destroyed by warmth and ultraviolet light.

#### *Methods of Administration*

Gonadotrophins are inactive by mouth and can only be employed parenterally. The injection is made *intramuscularly*. Being protein preparations, gonadotrophins can produce local and general anaphylactic reactions. For this reason, subcutaneous and intravenous injections should be avoided and a preliminary small test dose is desirable. The administration of gonadotrophins always calls for careful monitoring.

#### *Indications*

##### ***In the female***

The only indication for gonadotrophin therapy with FSH and LH in the female is to induce ovulation when the complaint is infertility. Amenorrhoea alone does *not* justify the treatment. Moreover, the only cases in which gonadotrophins can possibly be effective are those in which the ovaries contain ova, and when failure in ovulation is the result of absent or disturbed gonadotrophic function of the pituitary.

Thus gonadotrophins are used for induction of ovulation and superovulation in women unresponsive to clomiphene and tamoxifen; in IVF and other techniques of assisted reproduction; and in hypogonadotrophic women who may have normal follicular growth but impaired oestrogen synthesis. They may be used alone or in combination with GnRH agonists.

When the dominant follicle has formed, human chorionic gonadotrophin (hCG) is used to mimic the LH surge to release the ovum. It is used in women with documented evidence of poor luteal function to provide luteal support in the second half of the cycle and through the first trimester of pregnancy.

##### ***In the male***

*Oligozoospermia*: Except when failure in spermatogenesis by potentially normal testes is caused by established pituitary failure, the value of gonadotrophins for this condition is doubtful.

*Cryptorchidism*: Boys aged 5-14 years in whom neither testis has descended can be given hCG. However, 80 per cent of supposed undescended testes are merely retractile and many authorities take the view that in those cases in which the treatment encourages descent it is unnecessary because spontaneous cure would have occurred in time. Moreover, in most cases where spontaneous cure will not take place there is some local anatomical error which will always require surgery.

Nevertheless, hormone therapy may lengthen the spermatic cord and enable the testes to descend before they become too large for the canals. It is worth trying as a preliminary measure or as an adjunct to surgery. Although there is much dispute, some authorities claim that, after excluding retractile testes, a cure is obtained without surgery in 33 per cent of cases.

Gonadotrophin therapy in boys can cause troublesome, albeit temporary, precocious development and frequent erection of the phallus.

### Adverse Effects

- Local reactions at the site of injection
- General anaphylactic protein reactions
- The production of antihormone antibodies
- Multiple ovulation with multiple pregnancy
- Ovarian hyperstimulation syndrome resulting in pain, cystic change, enlargement, haemorrhage into the ovary and peritoneal cavity, peritoneal and pleural effusions. Death and arterial thrombosis with loss of limb are recorded as rarities.

### Contraindications

The use of gonadotrophins is contraindicated in the presence of tumours of the ovary, breast, uterus, pituitary, and hypothalamus; in pregnancy (except the therapeutic administration of hCG for luteal phase defects), lactation, or with undiagnosed vaginal bleeding; if there is hypersensitivity to the gonadotrophins or excipients in the formulation; if there is primary ovarian failure; if there are ovarian cysts; or if the sexual organs are malformed such that pregnancy cannot occur.

### ANTIGONADOTROPHINS

A variety of agents can be regarded as acting as antagonotrophins. These include oestrogens which depress the gonadotrophic function of the hypothalamic-pituitary system. Certain progestogens and androgens may, in large doses, have a similar effect and so lower the levels of gonadotrophins in circulation.

*Danazol* is a synthetic steroid derivative of ethisterone which is devoid of progestogenic and oestrogenic properties, except that it lowers the levels of FSH and LH in circulation — presumably by inhibiting the production of these hormones. The antagonotrophic action of danazol is so strong that it can suppress ovulation and menstruation; the drug is therefore of value in the treatment of endometriosis. It is administered by mouth, the dose being 200-800 mg daily, depending on the indications. It has also been used for the treatment of menorrhagia, mammary dysplasia and gynaecomastia. It is mildly androgenic and anabolic and can also produce systemic side-effects similar to those caused by progestogens and androgens.

*Gestrinone* is a 19-nortestosterone derivative which also decreases FSH and LH secretion but requires only twice-weekly administration. Indications and side-effects are similar to danazol.

The isolation and synthesis of GnRH and analogues of GnRH, agonistic and antagonistic, resulted in another group of antagonotrophin agents.

### GnRH Antagonists

GnRH antagonists act immediately to suppress gonadotrophin secretion. The antagonists are difficult to prepare and expensive. Many of them have severe adverse effects because they cause degranulation of mast cells. The histamine-releasing activities of Nal-Arg, Nal-Glu and SB-75 are high. Ganirelix and A7599/8 also have relatively high histamine-releasing activity. Azaline B and antide have low histamine-releasing activities; antide forms a gel with normal saline.

Antagonists have largely been superseded by GnRH agonists in clinical practice. However, their potential role in contraception, e.g. in combination with testosterone for long-acting male contraception, is being investigated. Nal-Glu administered for 3 weeks inhibits spermatogenesis.

### GnRH Agonists

Various GnRH agonists and superagonists are now available which include buserelin, leuprorelin, nafarelin, goserelin, triptorelin, histrelin and deslorelin. They are produced by a modification of the amino acid residues at positions 6 and 10 which makes them resistant to the action of pituitary amidases and increases their receptor binding affinity.

### Actions

GnRH agonists bind to the GnRH receptor in the pituitary and provide competitive inhibition of endogenous GnRH. Initially, a supraphysiological release of FSH and LH from the pituitary occurs ('flare'). Repeated administration produces the paradoxical effect of decreasing the synthesis and release of both FSH and LH and therefore of the gonadal steroid hormones, along with a loss of receptors, resulting in downregulation and a state of hypogonadism. The FSH and LH levels are thus increased on day 2-3 of administration and are down to castration levels by the second to third week.

**Therapeutic Applications**

*General Principles*

- GnRH agonists have a short half life of 2-6 hours.
- They are not active orally and have to be administered intramuscularly, subcutaneously, or intranasally.
- Administration of GnRH agonists can be on a daily basis but depot preparations are administered on a monthly basis; the interval depends on the indication. Intranasal administration is done 2-5 times per day.
- Depending on the phase of the cycle in which treatment is started and the duration for which it is continued, various protocols can be used, e.g. ultra-long, long, short and ultra-short.

**Methods of Administration**

Orally, GnRH agonists are not effective. They are administered by subcutaneous or intramuscular injections, as a nasal spray, sustained release implants or injections of biodegradable microspheres. The routes of administration, dosages and relative potencies of different agents are shown in Table 41.1.

**Indications**

*In the female*

GnRH agonists cause a ‘medical oophorectomy’ which has revolutionised the treatment of many conditions.

*Precocious puberty:* In true idiopathic GnRH-dependent precocious puberty, GnRH agonists are the drugs of choice, producing amenorrhoea, a rapid and substantial regression of pubertal characteristics and a reduction in

growth velocity, with increase in the final bone height if treatment is started early.

*Endometriosis and adenomyosis:* GnRH agonists suppress the disease effectively and produce significant symptomatic relief, reduce the size of deposits and, in infertile women, have a pregnancy rate comparable with danazol but with lesser side-effects. Adenomyosis has also been successfully treated with GnRH agonists.

*Leiomyomas:* Uterine size decreases by 30 to 64 per cent after 3 months of treatment with GnRH agonists, the decrease being both in the size of the leiomyomas and of the uterus itself. Symptomatic relief is also obtained. GnRH agonists are used preoperatively to facilitate myomectomy, especially hysteroscopic, by bringing about decrease in size, endometrial atrophy and decreased vascularity and intraoperative blood loss. When hysterectomy is planned, the decrease in size may make vaginal hysterectomy feasible. Unoperated, leiomyomas regain their size 3-4 months after stopping treatment. Very large submucous myomas can undergo degeneration and necrosis 5-10 weeks after starting therapy which may be symptomatic and cause significant vaginal bleeding.

Regression of leiomyomatosis peritonealis disseminata can also be achieved with GnRH agonist treatment.

*Dysfunctional uterine bleeding:* GnRH agonists are used in this condition when short-term relief is required as in a patient with renal failure awaiting transplantation, post-transplantation, or with blood dyscrasias.

*Infertility:* The role of GnRH agonists in endometriosis and in leiomyomas has been discussed above. GnRH

**Table 41.1: Route of administration, dosage, potency and chief indications of GnRH agonists**

GnRH agonist	Route of administration	Dosage	Relative potency*	Chief Indication
Buserelin (Suprefact)	Intranasal	900–1200 µg/day	100	Endometriosis, ART, Ca prostate
Leuprorelin (Lupron, Lucrin)	Subcutaneous	200 µg/day	100	Endometriosis, infertility, Ca prostate, hirsutism
Naferelin (Synarel, Nasarel)	Subcutaneous	0.1–1.0 mg/day	10-100	Endometriosis, infertility, Ca prostate, hirsutism
Goserelin (Zoladex)	Intramuscular	3.75 mg/month	200	Endometriosis, infertility, precocious puberty
Triptorelin (Decapeptyl)	Intranasal	400–800 µg/day	200	Endometriosis, infertility, precocious puberty
Histreltin (Supprelin)	Subcutaneous	3.6 mg/month	230	Endometriosis, pre-TCRE, Ca breast, myoma
	Intramuscular	2–4 mg/month	100	Endometriosis, Ca prostate, infertility, precocious puberty
	Subcutaneous	0.1 mg/day	100	Endometriosis, Ca prostate, infertility, precocious puberty
		10 µg/kg/day	100	Central precocious puberty

\*Potency of GnRH=1

agonists have revolutionised protocols for induction of ovulation. The use of GnRH in assisted reproduction techniques for downregulation of the hypothalamic—pituitary axis is one of the important reasons for the improved outcomes following IVF and other procedures.

In the induction of ovulation, administration of 0.1 mg leuporelin or triptorelin stimulates the LH surge, unlike hCG which mimics it.

**Premenstrual syndrome:** GnRH agonists are effective in treatment but long-term treatment is not possible because of side-effects. Introducing add-back therapy decreases the effect on PMS symptoms as well.

**Hirsutism:** GnRH agonist treatment improves hirsutism because ovarian androgen production is LH-dependent, but requires a greater dose. Results are improved when an oral contraceptive is added and it is more effective in severe hirsutism. Again, long-term therapy is difficult.

**Carcinoma breast:** The addition of GnRH agonists to tamoxifen as adjunctive therapy in breast cancer is found to improve the outcome and is now becoming the routine practice at some centres.

**Irritable bowel syndrome:** The use of GnRH agonists for this indication is under trial.

### **In the male**

**Cryptorchidism:** Short-term intranasal nafarelin is successful where cryptorchidism is not due to anatomical blockage. It stimulates the release of gonadotrophins, thereby stimulating secretion of gonadal steroids which mediate the descent of the testes – 30 per cent respond in 4 weeks.

**Carcinoma prostate:** GnRH agonists are as effective as orchidectomy in patients with carcinoma prostate. However, if there are neurological symptoms or life-threatening metastatic disease, antiandrogens should be started first. GnRH agonists are combined with antiandrogens (flutamide or nilutamide) to counter the effect of testosterone of adrenal origin.

**Benign prostatic hypertrophy:** Daily administration of leuporelin or nafarelin decreases obstructive urinary symptoms in 1 month although in some cases it may take up to 6 months. Regrowth occurs within 6 months after stopping therapy.

### **Adverse Effects**

In about 10 per cent of patients, a local allergic reaction may be seen at the injection site. Rarely, anaphylaxis may occur.

GnRH agonist use is associated with menopausal symptoms. Within 3-4 weeks of starting treatment hot flushes, vaginal dryness, headache, joint and muscle stiffness and depression occur. One-third of women experience irregular vaginal bleeding.

Osteoporosis occurs in a large proportion of patients who receive therapy for longer than 6 months and contrary to previous belief, may not be totally reversed after stopping treatment. Add-back treatment with combination oestrogen—progestogen or with tibolone as in standard HRT regimens decreases these side-effects without affecting the success of therapy. This allows prolongation of therapy beyond 6 months.

The diagnosis of a leiomyosarcoma can be delayed; if the myoma is either not shrinking or is growing, it should be operated immediately.

Pregnancy can occur during therapy if there is escape of suppression but no adverse effects on the foetus have been reported.

## **HYPOTHALAMIC HORMONES**

It has long been known that what were once regarded as posterior pituitary hormones, notably oxytocin and vasopressin, are in fact secreted by the hypothalamus and travel from there to the pituitary gland, by way of the axons of neurons. These are mainly concerned with stimulating the contractions of certain smooth muscles and with water balance and are not considered in this chapter.

The hypothalamus is now known to control chemically the secretion of the hormones of the anterior pituitary. It governs the functions of the pituitary by actively secreting specific and independent hormones. Several of these qualify for inclusion as sex hormones in so far that, via the pituitary, they are intimately concerned with the activity of the gonads, breasts and other glands.

### **Types and Sources**

The secretion of hypothalamic releasing hormones is controlled either by direct feedback mechanisms or by influences from environmental factors which act via the higher cortical centres. Feedback control is usually negative or inhibitory, thus depressing both production of the hypothalamic releasing hormone and secretion of trophic hormone from the anterior pituitary. A positive feedback mechanism is less common but is involved in the secretion of LH. Feedback is indirect if it operates



mainly upon the pituitary gland via the hypothalamus and direct if the effect is at the adenohypophysis itself. When pituitary hormones themselves inhibit secretion of releasing hormones a short or internal negative feedback mechanism exists.

The hypothalamic regulatory releasing hormones are thyrotrophin releasing hormone (TRH), gonado-trophin releasing hormone (GnRH), growth hormone releasing hormone (GHRH) and corticotrophin releasing hormone (CRH). Various substances including TRH and vasoactive intestinal peptide (VIP) are thought to act as prolactin releasing hormone. The release-inhibiting hormones are prolactin inhibiting factor (PIF) which is probably dopamine, growth hormone release-inhibiting hormone (GHRH) and possibly an MSH release-inhibiting hormone (MSHRH).

Some of the hormone-releasing hormones have been synthesised and have been found to be low molecular-weight peptides.

### Actions

Within the central nervous system, control of the hypothalamic releasing factors is mediated by the local synthesis of neurotransmitters — dopamine, serotonin and noradrenaline. Apart from controlling hypothalamic neurohormone secretion, these neuro-transmitters are also concerned with the regulation of sexual function, behaviour and mood. The response to the neurotransmitters may be modified by drugs. Dopamine is now considered to be a PIF. Bromocriptine is a dopamine agonist and its effect is typically seen in suppression of prolactin secretion. Also, it augments GH secretion in the normal individual but suppresses it in acromegaly. Similarly, methyldopa suppresses prolactin production and augments GH production. Beta-blocking agents augment GH responses to stress, whilst alpha-blocking agents have a reverse effect, although in anorexia nervosa hormonal responses show quicker recovery under the effect of alpha blockade.

The actions of the hypothalamic hormones are not entirely specific to their respective pituitary hormones. For example, TSHRH not only releases TSH; it causes a significant rise in the output of prolactin. In men, but not in women, it also stimulates the release of LH. There are many interactions in this complex system which are still not understood but it is known that GHRH inhibits the LH response to TSHRH. It should not be forgotten

that the hypothalamus also controls other important activities such as appetite, thirst and control of body temperature, through nervous mechanisms alone.

### Diagnostic Applications

#### *Thyrotrophin Releasing Hormone*

TRH is a useful diagnostic agent in difficult cases of hyperthyroidism: when injected into normal individuals it leads to a rapid rise in thyrotrophin; in patients with thyrotoxicosis it does not rise because of the feedback mechanism of excess circulatory thyroid hormone; many patients with hypopituitarism show a reduced or delayed rise in TSH; a normal TSH response to TRH rules out hyperthyroidism. With the introduction of extremely sensitive assays from TSH, this test is now seldom required.

#### *Gonadotrophin Releasing Hormone*

When injected intravenously into normal individuals, GnRH leads to a rapid rise in plasma LH and FSH concentrations. This is useful in evaluating cases of precocious puberty. Cases of true precocious puberty respond to GnRH with a rise in LH levels within the 2 hours following injection. Similarly, gonadotrophin deficiency can also be evaluated. The administration of GnRH should elicit a normal LH response in hypogonadotropic patients with hypothalamic lesions and a weak or non-existent response in pituitary disease.

Synthetic GnRH (Fertiral, Gonadorelin) is available as a 500 µg/ml ampoule. Pulsatile subcutaneous administration can induce both follicular maturation and ovulation in amenorrhoeic women with hypogonadotropic hypogonadism. However, its administration is both difficult and expensive, and it is not used in routine clinical practice. Relefact® is available as a 100 µg ampoule for the assessment of pituitary function.

The therapeutic applications of the GnRH analogues have been discussed above.

#### *Corticotrophin Releasing Hormone*

The normal rise in plasma cortisol concentration which follows the administration of CRH does not occur in adrenocortical insufficiency. In cases of congenital adrenal hyperplasia with normal 17-OH progesterone (17-OHP) levels, the administration of CRH will produce a rise in the 17-OHP level.

General Considerations	656
Types and Causes	657
Investigation of Vaginal Discharge	660
Treatment	661
Syndromic Approach to Vaginal Discharge	661

### GENERAL CONSIDERATIONS

Vaginal discharge may be bloodstained or otherwise. Here we are only concerned with a white, cream, yellow or greenish discharge which is often loosely and wrongly called 'leucorrhoea' - a term which should be reserved for only one type (*see below*).

The complaint of discharge depends very much on the ideas, powers of observation and fastidiousness of individual women. The vulva and vagina are normally moistened by secretion. Women who are overanxious, introspective, or suffering from fears of venereal disease and cancer tend to exaggerate this into something pathological. On the other hand, it is not uncommon to find women denying the existence of an obviously pathological discharge found during examination.

A woman sometimes complains of discharge when she really means *vulvar odour*. Vulvar odour is a normal secondary sex character arising partly from the secretion of Bartholin's glands but mainly as a result of the action of bacteria on the secretion of apocrine glands. Provided a reasonable standard of cleanliness is maintained, vulvar odour is never apparent to bystanders, and those women who complain of it have a disorder of the mind rather than the body. The idea usually arises from a misinterpretation of some innocent remark of an acquaintance, and thereafter becomes an obsession difficult to eradicate. The complainants adopt all possible means to ensure cleanliness yet still interpret every look or movement on the part of their fellow workers or social contacts as evidence that 'they smell'. Those women who have cause to complain of odour do not do so because they are as insensitive as they are dirty.

Despite the fact that nothing more than regular washing is necessary for hygienic purposes, women's magazines and those that advertise in them now advocate deodorant powders to be sprayed on the vulva and within the vagina in order to promote sexual attractiveness! They have the opposite effect if they destroy natural odour and, moreover, they are as harmful as they are unnecessary. Apart from inculcating a wrong mental outlook amongst girls and women, they are extremely likely to promote gross and painful local reactions, even ulceration of the vulva and vagina.

## TYPES AND CAUSES

### Physiological Discharges

#### Composition

The slight discharge normally seen at the vulva and in the vagina is a mixture of the following, all of which vary in amount and character with ovarian function.

- Vulvar secretions from Bartholin's, sebaceous, sweat and apocrine glands
- Vaginal discharge
- Cervical secretion
- Uterine secretion
- Fallopian tube secretion

This may also contain a contribution from peritoneal fluid.

#### Amount

The amount of vaginal discharge ordinarily present in the adult is such that the introitus feels comfortably moist but there is not enough to stain the under-clothing. It is *normally* increased to the extent of becoming noticeable in the following circumstances: at the time of ovulation when there is the 'ovulation cascade' from the cervix; during a few days premenstrually when there is increased secretion from all parts of the genital tract; during pregnancy when there is an increase in vaginal and cervical discharges; and during sexual excitement when there is an outpouring of Bartholin's secretion onto the vulva.

### Pathological Discharges

#### Leucorrhoea

Leucorrhoea means 'a running of white substance' and the term should be restricted to mean an excessive amount of the normal discharge. Leucorrhoea consists mainly of the cervical component. It is characteristic of the normal discharge that, although white or cream when fresh, it dries to leave a *brownish yellow stain on clothing*. The patient with leucorrhoea, therefore, nearly always talks of a 'brown discharge' and may deceive the medical attendant into thinking that it is blood stained.

Microscopically, the discharge contains mucus, epithelial debris, organisms of various kinds and, in the second half of the cycle, some leucocytes.

Leucorrhoea is a nuisance in that it stains clothing and, if the patient fails to bathe and change frequently,

causes excoriation and soreness of the vulva. *But it never causes pruritus* and is never offensive. It is more troublesome premenstrually, midcyclically and during pregnancy and can give rise to fears of cancer and of sexually transmitted diseases.

The causes of leucorrhoea are as follows:

#### At Birth

Newborn babies may have mucoid vaginal discharge for 1-10 days. This is due to stimulation of the uterus and vagina by placental oestrogens.

#### Puberty

Leucorrhoea is not uncommonly seen in young girls during the few years before and after the menarche. Behaving like a fussy mother does not make the child introspective, this is a temporary phenomenon which corrects itself.

#### Active or Passive Congestion of the Pelvic Organs, Especially of the Cervix

This results in increased secretory activity by the glands and is the mechanism whereby prolonged ill health, anxiety states and neurosis, sedentary occupation and standing for long periods in hot atmospheres cause leucorrhoea.

#### An Increase in the Glandular Elements in the Cervix

Such an increase occurs in the case of cervical erosion or ectopy, leading to a profuse, clear discharge.

#### Vaginal Adenosis

An excessive amount of clear discharge may be the first indication of the presence of areas of adenosis in the vagina.

#### Oestrogen-progestogen Oral Contraceptives

Some women who are taking combined oral contraceptives develop leucorrhoea. This is usually caused by the development of an ectopy on the cervix.

#### Regular Douching

Some women still harbour the misconception that regular douching improves genital hygiene. However, washing away of natural secretions encourages the cervix

to secrete more, particularly if irritant antiseptic solutions are used. It also predisposes to infection by washing away naturally protective lactobacilli and by altering the pH and is to be discouraged as a routine practice.

## Inflammatory Discharge

### Infections

Discharge caused by infection is mucopurulent or frankly purulent; its colour therefore varies from cream to yellow or green. It is often offensive, especially when coliform bacilli are present as primary or secondary invaders. Its chief microscopic characteristic is the presence of pus cells. The commonest lesions causing a discharge of this kind are as follows:

- *Vulvovaginitis*: This may be due to infection with the gonococcus, *Trichomonas vaginalis*, *Candida albicans* or bacterial vaginosis in the adult, and with non-specific organisms in childhood and old age
- *Cervicitis* gonococcal, chlamydial, anaerobic or puerperal; secondary infection of an erosion
- *Endometritis*, puerperal or senile
- *Secondary infection* of wounds, abrasions (including those caused by foreign bodies), burns, chemical injuries and neoplasms, sited in any part of the genital tract.

## Bacterial Vaginosis

Bacterial vaginosis (BV) has previously been referred to as nonspecific vaginitis or Gardnerella vaginitis. It is an alteration of normal vaginal bacterial flora that results in the loss of hydrogen peroxide-producing lactobacilli and an overgrowth of predominantly anaerobic bacteria. Lactobacilli are usually absent. It is not known what triggers the disturbance of normal vaginal flora. It has been postulated that repeated alkalisation of the vagina, which occurs with frequent sexual intercourse or use of douches, plays a role. Women with BV are at increased risk for pelvic inflammatory disease (PID), postabortal PID, postoperative cuff infections after hysterectomy, and abnormal cervical cytology. Pregnant women with BV are at risk for premature rupture of the membranes, preterm labour and delivery, chorioamnionitis, and postcaesarean endometritis. It is not known whether screening for, and treatment of, BV will decrease the risk for these adverse sequelae.

*Diagnosis*: Bacterial vaginosis is diagnosed on the basis of the following findings :

- a. A fishy vaginal odour, which is particularly noticeable following coitus, and vaginal discharge are present.
- b. Vaginal secretions are gray and thinly coat the vaginal walls.
- c. The pH of these secretions is higher than 4.5 (usually 4.7 to 5.7).
- d. Microscopy of the vaginal secretions reveals an increased number of clue cells, and leucocytes are conspicuously absent.
- e. The addition of KOH to the vaginal secretions (the "whiff" test) releases a fishy, amine-like odour.  
Culture of *G. vaginalis* is not recommended as a diagnostic tool because of its lack of specificity.

### Treatment

Ideally, treatment of BV should inhibit anaerobes but not vaginal lactobacilli. The following treatments are effective.

Metronidazole, an antibiotic with excellent activity against anaerobes but poor activity against lactobacilli, is the drug of choice for the treatment of BV. A dose of 500 mg administered orally twice a day for 7 days should be used or the same can be given as gel if available. An alternative regimen uses a single, 2 g oral dose of metronidazole. The overall cure rates range from 75 to 84 per cent for the above regimens. Clindamycin in the following regimens also is effective: Clindamycin cream, 2 per cent, one applicator full (5 g) intravaginally at bedtime for 7 days or Clindamycin, 300 mg, orally twice daily for 7 days. Alternatively Clindamycin ovules, 100 mg, intravaginally once at bedtime for 3 days.

*Trichomonal Vaginitis*: This is a sexually transmitted disease caused by a flagellated parasite. The parasite is an anaerobe that has the ability to generate hydrogen to combine with oxygen to create an anaerobic environment. It exists only in trophozoite form. Trichomonal vaginitis often accompanies BV, which can be diagnosed in up to 60 per cent of patients with trichomonal vaginitis.

*Clinical features*: Trichomonal vaginitis is associated with a profuse, purulent, malodorous vaginal discharge that may be accompanied by vulvar pruritus. It may be greenish yellow in colour. On examination of the vagina a patchy vaginal erythema and colpitis macularis ("strawberry" cervix) may be observed.

If a drop of saline is added to a drop of discharge motile organisms are seen in Trichomoniasis infection.

Metronidazole is the drug of choice for treatment of vaginal trichomoniasis. Both a single-dose (2 g orally) and a multidose (500 mg twice daily for 7 days) regimen are highly effective and have cure rates of about 95 per cent.

The sexual partner should also be treated.

**Vulvovaginal Candidiasis (Moniliasis):** This is frequently seen in a woman's life. The extensive areas of pruritus and inflammation often associated with minimal invasion of the lower genital tract epithelial cells suggest this infection. Factors that predispose antibiotic use, pregnancy, and diabetes.

**Diagnosis:** Curdy white discharge is typical of candidiasis. The vagina may be erythematous with an adherent, whitish discharge. The cervix appears normal. By adding 1 per cent KOH to a drop of discharge the vaginal epithelium gets dissolved and the hyphae will be seen in candidiasis.

#### Treatment

Topically applied drugs are the most commonly available treatment like nystatin. Symptoms usually take 2 to 3 days to resolve. There is a trend to shorten the duration of therapy to 1 to 3 days. Although the shorter period of therapy implies a shortened duration of treatment, because the short-course formulations have higher concentrations of the antifungal agent, they cause an inhibitory concentration in the vagina that persists for several days. An oral antifungal agent, fluconazole, used in a single 150 mg dose, has been approved for the treatment.

### Inflammatory Vaginitis

Desquamative inflammatory vaginitis is a clinical syndrome characterised by diffuse exudative vaginitis, epithelial cell exfoliation, and a profuse purulent vaginal discharge. The cause of inflammatory vaginitis is unknown, but Gram stain findings reveal a relative absence of normal long gram-positive bacilli (lactobacilli) and their replacement with gram-positive cocci, usually streptococci. Women with this disorder have a purulent vaginal discharge, vulvovaginal burning or irritation, and dyspareunia. Initial therapy is the use of 2 per cent clindamycin cream, one applicator full (5 g) intravaginally once daily for 7 days. Relapse occurs in about 30 per cent of patients, who should be retreated with

intravaginal 2 per cent clindamycin cream for 2 weeks. Alternatively pessary of clindamycin can be used.

### Chronic Cervicitis

In chronic cervicitis, leucorrhoea may be the chief symptom. Although it may not be as profuse as in acute cervicitis, this discharge may also cause vulvar irritation. The discharge may be frankly purulent and variable in colour, or it may present simply as thick, tenacious, turbid mucus. Intermenstrual bleeding may occur. Associated eversion (cervical erosion) or ectopy may present as a velvety to granular redness or as patchy erythema due to scattered squamous metaplasia (epithelialisation or epidermisation). Nabothian cysts in the area of the so-called transformation zone often occur. The Schiller test may show poorly staining or non staining areas. There is often some tenderness and thickening in the region of the uterosacral ligaments on pelvic examination, and motion of the cervix may be painful.

Lower abdominal pain, lumbosacral backache, dysmenorrhoea, or dyspareunia may occur occasionally related to an associated parametritis. Colposcopy and a pap smear is needed to rule out progressive lesions and treated later by a cryosurgery.

### Neoplasms

Neoplasms could be benign or malignant. Benign are the polyps from the cervix or uterus.

#### Cervical Polyps

Cervical polyps are small pedunculated, often sessile neoplasms of the cervix. Most originate from the endocervix; a few arise from the portio. They are composed of a vascular connective tissue stroma and covered by columnar, squamocolumnar, or squamous epithelium.

Asymptomatic polyps often are discovered on routine pelvic examination. Most are benign, but all should be removed and submitted for pathologic examination because malignant change may occur. Moreover, some cervical cancers present as a polypoid mass. Polyps arise as a result of focal hyperplasia of the endocervix. It is not known whether this is due to chronic inflammation, an abnormal local responsiveness to hormonal stimulation, or a localised vascular congestion of cervical blood vessels. Endocervical polyps are usually

red, flame-shaped, fragile growths and may vary in size from a few millimeters in length and diameter to larger tumours 2–3 cm in diameter and several centimeters long. These polyps are usually attached to the endocervical mucosa near the external os by a narrow pedicle, but occasionally the base is broad. On microscopic examination, the stroma of a polyp is composed of fibrous connective tissue containing numerous small vessels in the centre. Most polyps can be removed in the physician's office. This is done with little bleeding by grasping the pedicle with a haemostat or long grasping instrument and twisting it until the growth is avulsed. Large polyps and those with sessile attachments may require excision in an operating room setting. This will allow for anaesthesia to be administered for further visualisation and treatment using the hysteroscope and control of any haemorrhage.

If the cervix is soft, patulous, or definitely dilated, and the polyp is large, hysteroscopy should be performed, especially if the pedicle is not readily visible. Exploration of the cervical and uterine cavities with the hysteroscope allows for further identification of other polyps. All tissue must be sent to a pathologist to be examined for possible underlying malignant or premalignant conditions.

### Prognosis

Simple removal of cervical polyps is usually curative.

Any growth which is exposed to the lumen of the genital tract can cause a continuous discharge which is *at first white or cream and non-offensive*. Soon, however, the growth becomes ulcerated and infected as the necrotic tissue is exposed to the large number of organisms present in the vagina. The discharge then become purulent, offensive and blood-stained. Often the odour is so marked that it can be appreciated as soon as the woman enters the room. Such symptoms are characteristic of a malignant neoplasm but they may also be caused by benign lesions such as a cervical polyp or a sloughing submucous leiomyoma.

### Urinary and Faeculent Discharges

The causes of urinary incontinence, a condition which can be confused with a vaginal discharge, are described in Chapter 52. A vaginal escape of faeces betokens the presence of a fistula.

A urinary or faeculent discharge is usually recognised easily by its smell and colour but difficulty can arise in distinguishing a slight faecal escape from, say, the discharge of a senile pyometra.

### Rarities

These include the intermittent emptying of a hydro-salpinx and the discharge of ascitic fluid through the fallopian tubes and uterus. Intermittent, profuse vaginal discharge may occur in carcinoma of the fallopian tube.

## INVESTIGATION OF VAGINAL DISCHARGE

### Clinical History

A good idea of the type and cause of the discharge can be obtained from the following observations:

- Age of the patient
- Amount of discharge as judged by the need to wear a sanitary pad and by the staining of underclothing
- *Onset*: Leucorrhoea has a gradual onset. A sudden onset of discharge nearly always means infection or a chemical or physical insult. There may be a history of exposure to the risk of venereal infection or, in the case of candidiasis, a history of recent treatment with antibiotics.
- Relationship to menstruation, ovulation and pregnancy. Discharge alleged to date from pregnancy, and which might, therefore, at first be thought to be caused by puerperal infection of the cervix or other tissues, will often be found to have commenced *during* pregnancy and to be due to *Candida* infection. The symptoms of *Trichomonas* infection often begin during or after menstruation and tend to be worse for a few days after each subsequent period.
- *The use of toilet preparations*: These include douching and the application of antiseptics or deodorants.
- *Colour of discharge*: Care is necessary to distinguish between a brown or bloodstained discharge and the normal creamy discharge which dries leaving a brown or yellow stain on clothing.
- *Offensiveness*: If the discharge is offensive it is usually caused by a foreign body, infection, or neoplasm.
- *Pruritus*: Any discharge can cause excoriation of the vulva but none except those caused by infection with *Trichomonas vaginalis* or *Candida albicans* causes itching.

## Examination

After inspection of the vulva and of the openings of the vagina and urethra, a speculum is inserted to determine the nature and amount of the discharge, and to study the vaginal wall and cervix. Specimens are then obtained from the vagina, taking care not to contaminate them with lubricant. *These are examined primarily for pus cells.*

*If pus is not found*, then, irrespective of any organism present, it can be concluded that the discharge is a true leucorrhoea and not due to an infection. The finding of *non-specific* bacteria on cultures taken from the vagina, the discharge from which does not contain pus, *never* justifies the administration of antiseptics or antibiotics.

*If pus cells are found*, and unless an obvious cause such as cancer or a foreign body is revealed, the nature of organisms present must then be determined by study of fresh preparations, stained smears and cultures. The full investigation from the standpoint of gonorrhoea, bacterial vaginosis, candidiasis and trichomoniasis is described in Chapters 19 and 20.

## TREATMENT

The treatment of vaginal discharge varies with its cause. Foreign bodies must be removed, while infections and neoplasms are treated as described elsewhere (*see* Chapters 20 and 28).

Here we are concerned only with the treatment of *true leucorrhoea*. For this, little more than explanation and reassurance are usually necessary, especially when the discharge is noticed only premenstrually, at the time of ovulation, during pregnancy and in the course of taking oral contraceptives. Local remedies should be avoided as far as possible. Medicated pessaries are useless; douches tend to aggravate matters. Cleanliness is ensured by bathing and by changes of underclothing. General health should receive attention and anxiety states be corrected as far as possible.

The only local treatment necessary for leucorrhoea is that of a cervical erosion by cryotherapy, laser cautery or diathermy when it becomes reasonably certain that this is the cause of a persistent and resistant discharge after evaluation to rule out cervical dysplasia or malignancy (*see* Chapter 25). Except as a diagnostic procedure when there is a doubt of underlying malignancy, curettage has no place in the management of vaginal discharge.

## SYNDROMIC APPROACH TO VAGINAL DISCHARGE

The importance of reproductive tract infections (RTIs) in causing morbidity and long-term sequelae has been recognised by the World Health Organisation (WHO), which has recommended the syndromic approach to RTIs at the community level. In most cases, several different infections are found to coexist with RTIs; the availability of facilities for accurate laboratory diagnosis in peripheral centres is lacking, especially in developing countries; and patients are thus denied the benefit of prompt therapy in preventing sequelae.

The management of a patient presenting with vaginal discharge depends on the availability of a speculum and/or laboratory facilities. If a woman presents with a complaint of vaginal discharge to a health facility where even a speculum is not available, she and her partner are treated empirically for gonorrhoea, chlamydia, candidiasis, trichomoniasis and bacterial vaginosis if her partner has a genital ulcer or discharge. In the absence of a lesion in the partner, treatment for gonorrhoea is omitted from the above protocol.

If speculum examination is feasible, treatment is given according to the nature of discharge:

- mucopus — treat for gonorrhoea and chlamydia
- profuse discharge — treat for trichomoniasis and bacterial vaginosis
- clumped discharge — treat for candidiasis. If the partner has a lesion, the couple are given treatment for gonorrhoea and chlamydia as well.

If a microscope is available, a wet mount examination (with saline and KOH) is carried out to look for trichomonads, yeast cells and clue cells, and treatment given accordingly (*see* Chapter 20). Once again, treatment for gonorrhoea and chlamydia is added in all cases where the partner has a lesion.

If the problem persists after this primary management, the patient is referred to a higher care centre. A similar approach is being tried in the case of urethral discharge and genital ulcers.

Many gynaecologists are averse to this form of management as they find it contrary to scientific principles. However, due to the magnitude of the problem and the reasons cited above, evaluation and validation of this strategy as a public health measure is currently underway.

# Pruritus Vulvae and Vulvodynia

Pruritus Associated with Vaginal Discharge	663
Pruritus without Vaginal Discharge	666
Vulvodynia	669

## Definition and Incidence

Pruritus vulvae is a symptom which is experienced by not less than 10 per cent of women attending gynaecological clinics, although it is not always their primary complaint. It presents a clinical problem of unusual difficulty because it has many possible causes and, unless the cause is found, the treatment is usually unsatisfactory. Moreover, the sufferer from intractable pruritus is in a worse plight than one who experiences pain because itching is not relieved by the simple expedient of giving analgesics. There is no complaint which deserves more conscientious and sympathetic study.

Pruritus means *a sensation of itching* and it is important to restrict the term to this. When a woman complains of 'irritation' she often means that the vulva is painful, burning or tender - symptoms which differ from pruritus, not only in their nature but also in their underlying causes. It is therefore always necessary to make certain of the sensation by asking if it arouses a desire to scratch. It is equally important to determine accurately the site of the pruritus, and especially if it is vaginal, vulvar or anal. It is also necessary to know if other areas of the body are affected because the vulvar lesion may be merely one part of a widespread dermatological problem.

It is said that the sensation of pruritus is carried by somatic pain fibres and that it is a variant of pain. It is often regarded as a minimal pain sensation but clinical observation makes this difficult to accept. So far as the vulva is concerned, the causes of pruritus are different from those of pain; a diminishing degree of pain or soreness does not become an itch and, no matter how intense the itch, it does not develop into pain. Ultimately scratch lesions become painful, but even then the patient can distinguish between this sensation and the underlying itch.

Itching can arise from central as well as from peripheral stimuli. To read, write and think of pruritus, or to see another person scratching, is enough to start an itch. Moreover, the habit of scratching a particular part of the body is quickly acquired.

Irrespective of its aetiology, pruritus vulvae is generally more troublesome at night when the woman is in bed. This is partly because of local warmth and partly because there are fewer distractions.



### Natural Defence Mechanisms

The vagina has an acidic pH (around 4 – 4.5) where only Doderlein's bacilli can survive. The presence of these bacilli is associated with the production of lactic acid, which makes the vagina naturally self-sterilising. This hostile acidic pH may be raised at certain times, such as during menstruation (cervical and endometrial discharge is alkaline), after abortion or labor (lochia is alkaline) or with excessive cervical discharge. As the pH rises and becomes alkaline, non-resident pathogens are able to grow. Apart from the acidic medium, the vagina has a tough stratified squamous epithelium that presents a smooth surface against pathogens; there are no crypts unlike the endocervix where organisms can multiply.

The proximity of the urethral opening to the vaginal orifice and also to the anal orifice predisposes the potentially pathogenic organisms (PPMs) to invade the urogenital tract and cause infections (Fig. 43.1).

### Causes

*Common Causes should be ruled out first like Vulvovaginitis, Food and Drug Allergies and Contact Dermatitis*

The chemical substances found in the body which are known to induce a sensation of itching include potassium, histamine, 5-hydroxytryptamine and plasma kinins. Hence the release of such substances into the tissues of the vulva is probably the mechanism whereby

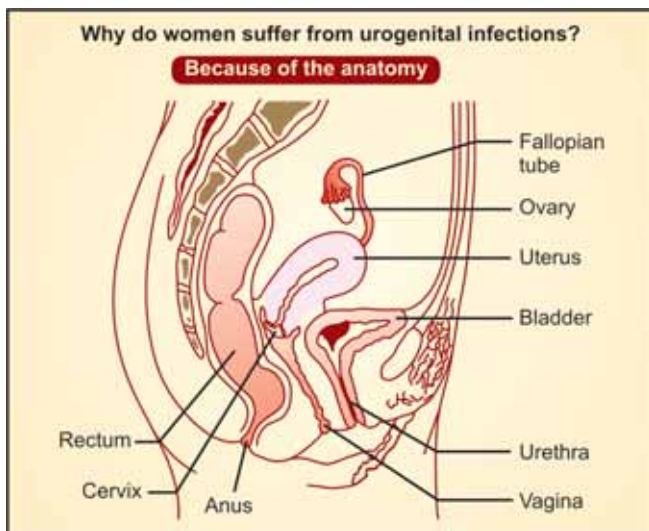


Fig. 43.1: Normal female urogenital anatomy

the factors causing itching operate. Their release may be mediated by some vascular change (*see below*).

### PRURITUS ASSOCIATED WITH VAGINAL DISCHARGE(LEUCORRHOEA)

The term leucorrhoea should be used to denote the normal vaginal secretions that are increased in amount. An increase in the normal vaginal secretions develops physiologically at puberty, during pregnancy, at ovulation and sometimes in the premenstrual phase. Some clinicians use the word leucorrhoea to describe any white or yellowish white discharge from the vagina. Non-pathological leucorrhoea can be classified as cervical and vaginal. Any vaginal discharge that is frankly purulent and contains pus cells should be considered to be due to a specific vaginal infection.

### Vaginal Discharge

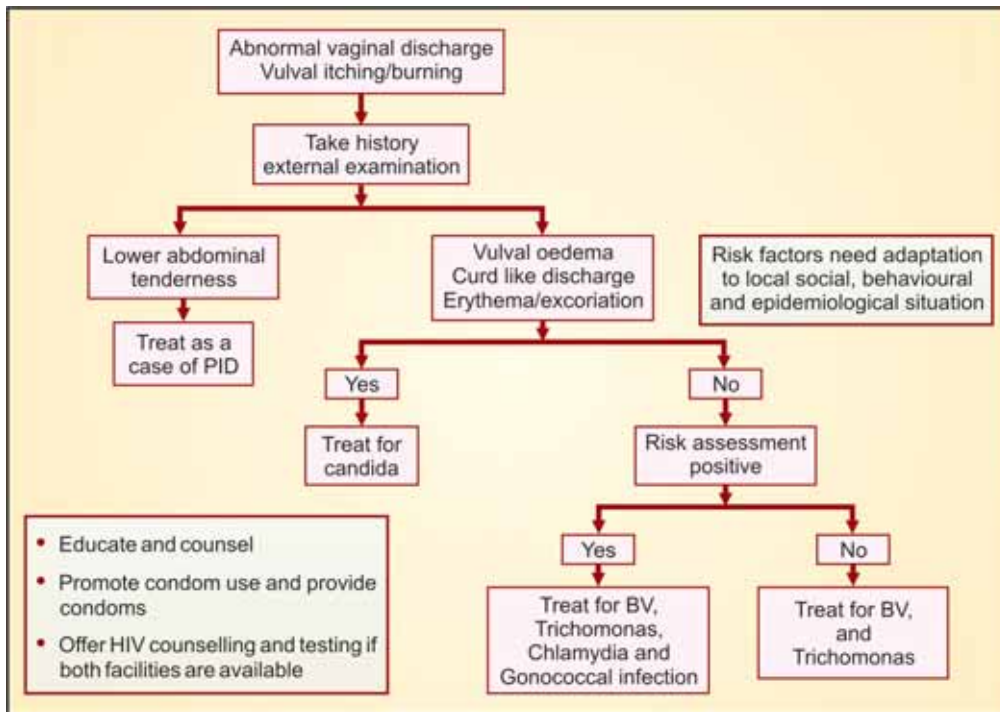
Infection is the commonest cause of vaginal discharge. Vaginal discharge can result from vaginitis, cervicitis or both. Cervicitis can be present without symptoms. Vaginal discharge can be due to STIs like chlamydia and gonococci or more commonly due to non-sexually transmitted infections like candida, trichomonas or bacterial vaginosis (RTIs) (Flow chart 43.1).

### Vaginal Yeast Infection (Candidiasis, Moniliasis)

Vaginal yeast infection is an RTI and not an STI. It is caused by gram-positive fungus *Candida albicans* that flourishes in the acidic vagina. Normal vaginal flora is dominated by lactobacilli. Candidiasis occurs when the normal environment in the vagina changes. This can occur after administration of broad-spectrum antibiotics, oral contraceptives or other steroids. A woman can develop a candidial infection if she is immuno compromised, such as diabetes, HIV infection.

Classically, candida causes intense vulval and vaginal pruritus with profuse curdy discharge. Some women may complain of superficial dyspareunia. On examination, there may be inflammation of the vulva, especially the labia minora and introitus, with excoriation. The discharge is thick, white and has appearance of "cottage cheese". The discharge often adheres to the vagina in the form of white patches or plaques, and when removed, multiple petechial haemorrhagic areas are left behind. Vulvar candidiasis may produce erythema and oedema as well as satellite lesions. Other than extreme discomfort

Flow chart 43.1: Vaginal discharge



from skin irritation in severe infections, there are no complications from vaginal yeast infections. A wet saline mount with 10 per cent KOH is diagnostic of candida.

### Trichomonas Infection

In clinical practice, trichomoniasis is the most common and important vaginal infection in women. Trichomonas infection is an STI caused by the flagellate protozoan, *Trichomonas vaginalis*. Trichomonas is an actively motile anaerobe; three types are known, namely, *T. buccalis*, *T. hominis* and *T. vaginalis*. Only *T. vaginalis* can survive in the vagina. Trichomoniasis is almost always seen in women in the reproductive age, and though the commonest mode of transmission is sexual, it may be acquired through improper hygiene. It may occur in conjunction with gonococcal infection. In pregnant women, trichomonas infection can cause preterm labour and delivery.

Up to 50 per cent of women who are infected are asymptomatic, but they can still pass the infection to their partners. Patients characteristically present with malodorous vaginal discharge and pruritus. The discharge is profuse, thin, creamy or slightly green in

colour and frothy. Pruritus and inflammation of the vulva is present. Multiple small punctate strawberry spots may be seen on the vagina and portio vaginalis. Associated symptoms like dysuria, dyspareunia, lower abdominal pain and backache may also be present. Secondary infection may sometimes be seen, usually with *E. coli* or pathogenic cocci. A fresh wet film preparation showing actively motile flagellates of *T. vaginalis* or cytological smear is diagnostic.

### Bacterial Vaginosis (BV)

BV is an RTI but not an STI, although it is more common among sexually active women. Bacterial vaginosis produces a disturbance of the normal vaginal flora. The normally predominant lactobacilli are reduced and replaced by a number of organisms including *Gardnerella*, *Ureaplasma*, *Bacteroids* and other anaerobes. Classically bacterial vaginosis presents with white or grey fishy smelling vaginal discharge.

Bacterial vaginosis can lead to serious complications after invasive procedures such as curettage or endometrial biopsy. In pregnant women, BV can cause premature rupture of membranes, preterm labour and

delivery, chorioamnionitis, and delivery of a low birth weight baby.

Besides these vaginal infections, leucorrhoea can occur because of cervicitis caused by chlamydia and gonococci.

### Chlamydia Trachomatis

It is the most common of all bacterial STIs, with more than 3 million new cases occurring each year. Symptoms include abnormal vaginal discharge and burning during urination. If untreated, chlamydial infection may lead to pelvic inflammatory disease, ectopic pregnancy and infertility.

### Neisseria Gonorrhoeae

Another cause for cervicitis is infection with *N. gonorrhoeae*, which is a major STI in both men and women. Green or yellow vaginal discharge, abnormal vaginal bleeding or pelvic pain, burning micturation and genital lesions may be present.

It is commonly stated that any type of vaginal discharge can cause pruritus vulvae; this is not true. Purulent and mucopurulent discharges cause pain and tenderness when the vulva gets chafed but they never induce *itching*. *The only discharges* associated with pruritus are those caused by vaginal infestation with either *Trichomonas vaginalis* or *Candida albicans*; these account for at least 80 per cent of all cases of pruritus vulvae. In these the itch tends to be situated within the introitus as well as on the vulva; it may be out of all proportion to the amount of discharge, so the diagnosis is easily missed. Whenever an itchy discharge is reported free from *T. vaginalis* or *C. albicans* it requires re-examination; if a sufficiently thorough search and culture of several specimens is made, these organisms will always be found.

When there is little discharge to collect, specimens should be obtained on a swab previously moistened with Feinberg-Whittington medium. This technique is also the best for taking specimens from the urethra and from the vulvar skin, in which sites *Candida* and *Trichomonas* organisms can sometimes be found, even when they are not demonstrable in the vagina.

Sexually transmitted infections (STIs) are infections that are primarily passed from person to person by sexual contact, and STIs are part of a broader group of infections known as reproductive tract infections (RTIs) that include all infections of the reproductive tract, including

those not caused by sexual contact. The common vaginal and cervical infections that cause leucorrhoea can be classified as STIs and RTIs.

Sexually transmitted infections (STIs) are a major public health problem in both developed and developing countries, but prevalence rate is apparently higher in developing countries, where STI treatment is less accessible. The WHO has advocated the syndromic approach for the management of STIs as many health care providers lack time or equipment to diagnose them. This approach which bases diagnosis on a group of symptoms and signs and treating all diseases that could cause the syndrome, makes diagnosis more accurate without extensive laboratory tests and allows treatment with a single approach.

Infection with an STI might lead to symptoms in the reproductive organs themselves, in the skin around the genitals or anus, or in the throat or mouth. Some STIs may lead to systemic symptoms and complications, while others may be asymptomatic.

### Why Should Reproductive Health Services Focus On STIs/ RTIs?

STIs and other RTIs are a rapidly growing problem throughout the world. Although the impact of STIs is serious in both developed and developing countries, it is most profound in the developing world. In some developing countries, STI prevalence rates of 5 to 52 per cent have been reported among women attending antenatal and family planning clinics. Today, STIs and other RTIs are among the most common problems for which women in the developing world seek health care services.

### Symptomatology of Vaginal Discharge

The following symptoms may be used to diagnose specific organisms:

- *Unusual vaginal discharge*: Bacterial vaginosis, chlamydia, gonorrhoea, trichomoniasis, candidiasis
- *Genital itching*: Bacterial vaginosis, trichomonas infection, candidiasis
- *Abnormal and/ or heavy vaginal bleeding*: Chlamydia, gonorrhoea (*This symptom is often caused by factors other than STIs*).
- *Post coital bleeding*: Chlamydia, gonorrhoea
- *Lower abdominal pain*: Chlamydia, gonorrhoea
- *Persistent vaginal yeast infections*: HIV / AIDS

## PRURITUS WITHOUT VAGINAL DISCHARGE

The remaining 15-20 per cent of cases of pruritus vulvae come under this heading and are difficult clinical problems. In this group, some of the causes are clearly defined and beyond dispute but some remain hypothetical or unknown.

### Generalised Pruritus

Occasionally pruritus vulvae is only part of generalised pruritus, such as is seen in lymphoma, jaundice, uraemia and other toxic states. This possibility is merely one to be kept in mind, as is that of a drug-induced condition. These emphasise the need to ascertain the exact site or sites of the discomfort in every case.

### Skin Diseases Not Specific To The Vulva

Examples which fall under this heading are *psoriasis*, *seborrhoeic dermatitis* and *scabies*. The vulvar lesion may be more obvious than those elsewhere and the latter need to be looked for carefully.

Psoriasis of the vulva can occur without any extragenital lesions. The lesion is characteristically red to the naked eye but is often atypical in appearance. Fortunately, it has well-defined histological features and these permit a firm diagnosis by biopsy.

*Apocrine miliaria* (Fox-Fordyce disease), comparable to prickly heat, is another cause of pruritus vulvae. It presents as multiple, small, discrete, skin-coloured or red papules which are considered to be the result of obstruction of the ducts, or of changes in function of the apocrine glands. This disease also occurs in the axilla and on the areola of the breast. Attacks can be precipitated by emotional upsets including sexual excitement.

*Squamous cell carcinoma* of the vulva causes itching in its early stage. *Carcinoma in situ* and *Paget's disease* of the vulva can cause pruritus of long standing.

### Animal and Fungal Parasitic Infections

*Pediculosis* causes pruritus pubis rather than pruritus vulvae. *Candidiasis* of the vulva is a not uncommon cause and is demonstrated as described above. There may be simultaneous infections of the nail beds on the hands and feet (*see* Chapter 20 for details).

### Diseases of the Anus and Rectum

Faecal incontinence, fissure *in ano* and haemorrhoids, even if they cause pruritus ani, can be dismissed as causes

of pruritus vulvae. Threadworms (*Enterobius*) only rarely migrate forward enough to cause *vulvar* itching.

Pruritus ani in the adult appears mostly to be caused by a fungus, usually *Candida*, or to be directly or indirectly associated with a fungal infection of the hands and feet. This sort of basis should be suspected whenever pruritus ani and pruritus vulvae occur together. In perianal candidiasis the focus of infection is often in the bowel.

### Conditions of the Urinary Tract

Bacilluria, pyuria, highly acid urine, incontinence of urine, and haematuria *never* cause pruritus vulvae, although they may cause chafing and soreness.

The only urinary condition associated with pruritus vulvae is *glycosuria* and this operates no matter whether it is a manifestation of diabetes or of a lowered renal threshold. The characteristic features of the lesion are its distribution according to the area of contamination with carbohydrate, and its colour, which resembles that of raw beef. In long-standing cases, a hyperkeratotic epithelial disorder can develop.

In making the diagnosis of diabetes, examination of the urine should not be relied upon; this may be sugar-free if the patient has not eaten for several hours at the time of examination. The only safe rule is to carry out a glucose tolerance test in every case in which the explanation of pruritus vulvae is not clear. Another reason for this is that *hyperglycaemia without glycosuria* can cause pruritus.

In the early days of oestrogen therapy a post-menopausal woman was referred to Professor Jeffcoate on account of pruritus vulvae. No obvious cause was found and the then much-acclaimed new treatment was applied. Secondary infection of the vulva cleared and the itching improved but was not cured. The patient then had a small uterine bleed which was credited to the hormone therapy. On her return from abroad 1½ years later, she reported that on medical advice she had continued the oestrogens intermittently with temporary benefit and had had one or more episodes of uterine bleeding. The situation appeared unchanged and Professor Jeffcoate prescribed further courses of oestrogen. Three years from the time of her first visit this patient reported parasthesiae of the hands and feet. The urine was still sugar-free, as it had been when tested on six previous occasions. However, the fasting blood sugar was 350 mg/dl and the cause of the pruritus was

at last clear. Just about the time that mystery was solved a nodule of carcinoma was found in the vaginal wall — a metastasis from carcinoma of the body of the uterus which had probably been present for 3 years and whose symptoms had been dismissed as being due to oestrogen therapy.

### Allergy and Drug Sensitivity

Skin sensitivity to various chemical constituents of toilet preparations such as soaps, bath salts, deodorants and antiseptics containing phenols or cresols, occasionally explains pruritus. Contact dermatitis from all sorts of cosmetics, even varnish on the patient's nails, is also a possibility.

The modern fashion of girls and women to wear close-fitting undergarments made of man-made fibres, is a common cause of pruritus vulvae. The abrasions which such clothing sometimes cause are not, however, responsible for the itch. This is the result of skin sensitivity to nylon or similar material or, more often, to the soaps and detergents used in washing the articles, these not being thoroughly rinsed afterwards. Women not prepared to abandon fashion have therefore only to wear cotton pants beneath the tights, or to be careful to wash them only with bland soaps and to rinse meticulously, to have their symptom relieved.

Sometimes antiseptic preparations used in the treatment of vaginitis are the cause of pruritus, or lead to its continuance after the original causal infection is under control. Preparations containing benzocaine or other local anaesthetics are especially liable to produce skin reactions and should never be applied to the vulva or vagina (Fig. 43.2).

A relationship between pruritus and coitus can often be traced to an idiosyncrasy to chemical or rubber constituents of contraceptives.

Urticarial conditions of the vulva maybe associated with a general skin reaction, and occasionally they form the predominant manifestation of sensitivity to medicaments of various types.

The more cases one sees of pruritus vulvae, the more importance one is inclined to attach to allergy as a cause. Moreover, in many cases in which another cause for pruritus is found, there is often an allergic factor operating as well; dermatographia is a common finding in sufferers from pruritus vulvae but the significance of this is doubtful.

Autoimmunity as a possible basis deserves study.

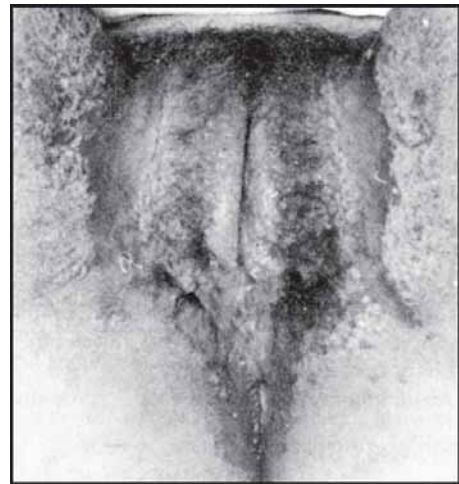
### Deficiency States

The part played by various deficiency states in causing pruritus vulvae is now generally recognised. Attention tends to be focused on avitaminosis A and B<sub>2</sub> but other agents operate and among these may be mentioned iron, folic acid and vitamin B<sub>12</sub>. Pruritus vulvae is therefore not uncommonly a manifestation of hypochromic or macrocytic anaemias and its investigation sometimes leads to their diagnosis. In such cases it responds quite dramatically to the treatment appropriate to the particular type of anaemia.

The vulvar lesions found in deficiency states vary from slight reddening, or pallor and oedema, to a vulvar hyperkeratotic epithelial disorder (*see* Chapter 26 and Fig. 43.3). As might be expected, they are often associated with glossitis, cheilosis and angular stomatitis (Fig. 43.4).

In the developed countries, deficiency states rarely arise as a result of gross dietetic errors but these should be looked for, especially in elderly women living alone who do not trouble to prepare proper meals. More often they are due to some disturbance of the alimentary tract which interferes with biosynthesis or with absorption. They occur, for example, in *chronic diarrhoea*, *malabsorption syndromes* and also as part of the *postgastrectomy syndrome*.

An important factor in this respect is *achlorhydria*, and a test for gastric acidity is advisable in the investigation of intractable pruritus vulvae. If hypochromic anaemia is present, iron is given in addition.



**Fig. 43.2:** Exfoliative dermatitis of the vulva occurring as an acute reaction to the application of a local anaesthetic ointment for pruritus vulvae. The ointment was prescribed empirically for itching which proved to be caused by candidal vaginitis and not only caused this skin change but made the pruritus worse

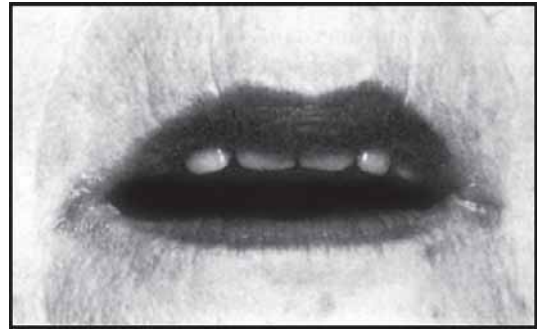


**Fig. 43.3:** A hyperkeratotic vulvar epithelial disorder which would formerly have been labelled leucoplakia. The patient in this case, who complained of pruritus, also had a histamine-fast achlorhydria but was not cured by the administration of hydrochloric acid. Once the skin changes reach this stage they may be irreversible

### Psychological Factors

A close relationship between the mind and the skin, and the part played by psychological upsets in causing skin disease, are recognised by all. Moreover, many mental disturbances have a sexual basis. So it is not surprising that the skin of the vulva can become the site for manifestations of psychoneuroses. Even when there is a local stimulus to cause pruritus, the state of the central nervous system remains important so far as the interpretation of the sensation is concerned. Under conditions of nervous fatigue, rough clothing or other surface irritants will cause itching when they would not otherwise do so. Tiredness explains in part why pruritus vulvae is always worse at night-time. It then interferes with sleep and leads to further nervous exhaustion so that a vicious circle is created.

Again, a scratch habit is easily developed and may be started off by some fleeting minor lesion which, although it heals quickly, leaves the habit behind. In such a case the pruritus is often limited to one area of one labium, the skin of which becomes thickened and hard as a result of scratching to give rise to the lesions called *neurodermatitis*.



**Fig. 43.4:** Angular stomatitis associated with pruritus vulvae and indicative of a deficiency state

### Epithelial Disorders of the Vulva

The most intense and persistent pruritus is associated with benign epithelial disorders of the vulvar skin. These are described in Chapter 25. Often their underlying cause is obscure; sometimes they appear to be the result of one or more of the various aetiological factors described above. Thus they are not infrequently found in proved cases of deficiency states, diabetes, and fungus infection.

One observation which makes it difficult to accept this concept is that hyperkeratotic epithelial changes cannot always be cured by treatment of what is thought to be the cause (Fig. 43.3). As noted elsewhere this evidence is not conclusive because the lesion may represent a stage at which the skin change has become irreversible. This suggestion is in keeping with observations to the effect that in ariboflavinosis the essential pathology is capillary damage, and that the vascular disturbance ultimately leads to permanent skin changes.

### Chronic Vascular Changes

In line with the above concept it is relevant to point out that nearly all lesions which cause itching in any part of the body have a vascular change as a basis; urticaria, nettle stings, insect bites and varicose veins are good examples. Is the same true of vulvar states associated with pruritus? Examination of the known causal factors suggests that it may well be so.

### Investigation

The more careful the investigation, the more likely is the cause of the pruritus to be found and the treatment to be successful. The special points in clinical examination, and

the particular tests to be applied, follow rationally from consideration of possible causes, and are mentioned elsewhere. Whatever their aetiology, however, chronic epithelial changes necessitate skin biopsy to exclude cancer or a cancer threat.

### Treatment

When a specific and clear cause is found and treatment directed to it, the pruritus is invariably cured or controlled. Parasitic and fungal infections can be eliminated, glycosuria can be controlled and deficiency states corrected. Antigens can be avoided.

When an underlying cause cannot be discovered or is doubtful, treatment has to be tentative or empirical and the results are less than satisfactory.

In such cases, general measures include advice on the wearing of loose-fitting cotton underclothing which is regularly and properly washed, and on keeping the vulva well-aerated by day and night. Sleep is promoted by giving appropriate drugs, if required.

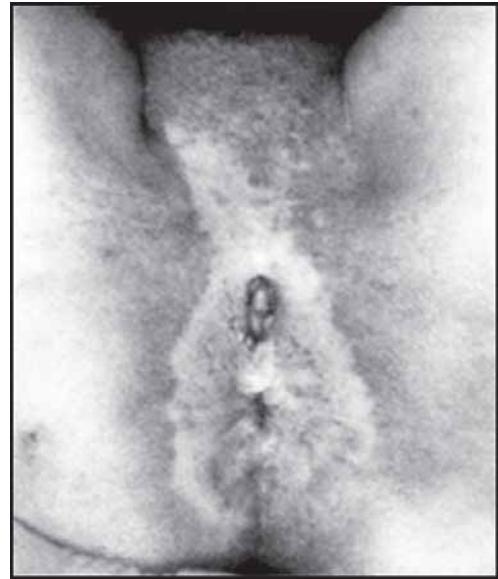
Otherwise, the lines of possible treatment are as described in detail in Chapter 25. In summary, the best of these are antihistamines (systemically, *not* locally); various fungicides (even when a fungal infection is not proven); and hydrocortisone or other corticosteroid preparations locally. A combination of fungicide and corticosteroids in ointment form can be particularly helpful.

When the pruritus is perianal as well as vulvar, a course of treatment with oral fungicides, as well as local applications, is indicated. The patient should also be instructed to *wash* the affected area after each act of defaecation, for an indefinite period in the future and even when apparently cured, if she is in the habit of using toilet paper.

All remedies have to be applied regularly and pertinaciously for months if not years. Empirical treatments to be avoided are local anaesthetics applied superficially or by injection and vulvectomy (unless the epithelium is shown to be unruly) (Chapter 25 and Fig. 43.5). Local applications of yoghurt or proprietary preparations containing lactobacilli have not been established to be beneficial.

### Results

The difficult and intractable case of pruritus vulvae leaves such an impression that it is easy to become



**Fig. 43.5:** The common, if not usual, end result of empirical vulvectomy for 'leucoplakia'. In this case a woman aged 72 years had had vulvectomy carried out several years previously but her pruritus quickly recurred and became even more troublesome. There is a recurrence of a hyperkeratotic lesion, and skin depigmentation, around the introitus and the anus. Investigation showed infestation with *Candida* organisms but these might represent a secondary infection

pessimistic and to overlook the cures. It should be emphasised therefore that, provided a proper investigation to find aetiological factors is carried out, a cure or considerable relief can be achieved by one means or another in 90 per cent of *all* cases.

### VULVODYNIA

Chronic painful vulvar discomfort as distinguished from pruritus vulvae is seen in up to 15 per cent of patients. Various sensations like burning, rawness, stinging or aching are described. These may or may not be associated with surface changes.

This complex condition has been divided into 5 categories - vulvar vestibulitis syndrome, dysaesthetic vulvodynia, vulvar dermatoses and dermatitis, vaginismus and cyclic vulvovaginitis.

The vulvar vestibulitis syndrome is most commonly seen in the reproductive age group, usually in women who are sexually active. Diagnostic criteria are: severe pain on vestibular touch or attempted vaginal entry; tenderness to pressure localised within the vulvar

vestibule; and physical findings confined to vestibular erythema of various degrees. All other causes of vulvodynia and vaginitis must be excluded by microscopy, culture and vulvoscopy.

### Three Approaches to STI/ RTI Diagnosis

The management of sexually transmitted infections (STIs) and reproductive tract infections (RTIs) can be difficult. Testing is often not available in low-resource settings, so diagnosis must be made based on symptoms and signs. Three clinical, aetiological and syndromic approaches have been devised to aid management of these cases.

#### The Clinical Approach

Clinical management is the least reliable of the three approaches. Using the clinical approach, a health care provider relies on his or her own experiences to arrive at a specific diagnosis based on the symptoms reported by the client and the clinical signs observed during physical examination. Clinical diagnosis can be problematic because:

- STIs often vary in the way they appear upon examination (i.e., they do not appear as a “textbook” case)
- A patient may have more than one infection at a time, making clinical diagnosis more difficult
- Previous self-treatment or previous treatment by another provider (or a traditional healer) may alter the signs and symptoms by the time the patient comes to the clinic
- Some infections are impossible to differentiate, even by highly trained providers, based solely on their signs and symptoms

Studies have shown that even highly experienced STI specialists using clinical diagnosis will fail to make the correct diagnosis and will miss concurrent infections in a significant number of cases. Even though the clinical approach is the least reliable of the three approaches and often results in misdiagnosis, it is the most common in many low- resource settings where laboratory services are not available or where providers are not trained in or do not recognise the effectiveness of the syndromic approach.

#### The Aetiological Approach

The aetiological approach, the most traditional and accurate of the three, is based on the results of laboratory

tests. These tests identify the specific infectious agent, which then determines the treatment to be administered. Although this approach is the most reliable and desirable for management of STIs/ RTIs, it is often not available to health providers in the developing world because it depends on trained laboratory technicians, availability of laboratory supplies, and in some cases expensive, specialised equipment. Additionally, this method may require the client to return for a second visit in order to collect laboratory results and receive treatment. This method may thus not be effective for vaginal infections.

#### The Syndromic Approach

Because of the unavailability of laboratory tests in many low-resource settings and the potential for inaccuracy when providers rely on the clinical approach alone, **syndromic management** is often the best approach in low-resource settings.

#### Syndromic Approach

In this approach, diagnosis is based on the identification of **syndromes**, which are combinations of the symptoms the patient reports and the signs the health care provider observes. The recommended treatments are effective for *all* the diseases that could cause the identified syndrome. However, syndromic management cannot address the widespread problem of **asymptomatic infections**, in which clients do not experience any symptoms at all. The syndromic approach, which has been recommended since 1990 by the World Health Organisation (WHO) for use with clients who present with symptoms of STIs, consists of four elements:

1. **Classification by syndrome:** Classifying the main causal pathogens by the syndromes they produce
2. **Use of algorithms:** Using flowcharts to guide the management of a given syndrome
3. **Treatment and counselling:** Using often more than one treatment that addresses all the pathogens with potential to cause a given syndrome
4. **Treatment of partners:** Promoting treatment of sex partners.

To be most effective, the syndromic approach should be backed by scientific data on the local prevalence of STIs and drug susceptibility of the infectious agents and must be supported by appropriate health education. Although syndromic management may be more appropriate than laboratory-based approaches in many



settings, this approach is of limited usefulness when applied to vaginal discharge, which is more often related to non-sexually transmitted RTIs than STIs. For the syndromic approach to be more effective, the risk of a client for STI should be assessed.

### STI Risk Assessment For Women

STI risk assessment involves using clients' responses to questions about symptoms of STIs, demographic characteristics, and behaviours to gauge their risk of exposure to infection, and to help them perceive their own risk. Risk assessment can be done in various ways and used for various purposes. It can be used as part of prevention counselling, as a way to determine who should be tested or treated for STIs, or as an adjunct to syndromic management algorithms.

Questions about risk often focus on various factors including: age, marital status, current or past STI symptoms, number of sexual partners, nature of relationships, the possibility of partners having other sexual partners, and current symptoms in partners. Risk assessment can be done using a brief checklist, which is more appropriate for screening purposes. Providing information about risks and asking clients to self-assess whether or not they are at risk without revealing specific information can also be done. This approach is often used where it is deemed culturally inappropriate to probe for more specific information. More often, information about specific practices and circumstances of the individual client is sought as part of an interactive, exploratory counselling process.

For example, during counselling, a provider can help clients to determine and perceive their individual risk of acquiring an STI/ HIV, as well as becoming pregnant. This requires not only providing information about transmission and risks in general, but also exploring the clients' and partners' particular sexual practices and history, as well as contextual factors of their lives that may make them vulnerable to infection. Providers should keep in mind the many factors that may influence a woman's perception of her risk, including the fact that she may see herself as safe if she is monogamous, without recognising the risks posed by her partner's behaviour. Likewise, young people often do not perceive their risk of infection due to feelings of invulnerability and lack of future focus.

### Use of Risk Assessment in the Vaginal Discharge Algorithm

STI risk assessment has been promoted for use in conjunction with the vaginal discharge algorithm as a way to determine appropriate treatment and, thus, improve the effectiveness of syndromic management. The idea is that vaginal discharge in women who are determined to be at high risk for STIs would be more likely related to cervical infections (gonorrhoea and chlamydia) than to vaginal infections.

However, risk assessment has not been found to be very precise in these instances (i.e., women without cervical infection often appear as high risk on assessments and vice versa) and provides only marginal improvement in the vaginal discharge algorithm compared to when it is not used.

More research is needed to better understand the purpose of risk assessment, its limitations, and its appropriate use. For example, in settings where chlamydia testing is available, risk assessment might be useful to decide who should have a chlamydia test. Chlamydia testing following risk assessment has been successful in decreasing chlamydia prevalence in some parts of the United States.

### Classification By Syndromes

In this approach, STIs are classified by syndrome. Each syndrome is made up of a combination of symptoms and clinical signs identified upon examination. The four main syndromes are:

- *Urethral discharge*: men
- *Lower abdominal pain*: women
- *Vaginal discharge*: women
- *Genital ulcer*: men or women

### Vaginal Discharge Syndromes

Vaginal discharge can result from vaginitis or cervicitis or both. It is very important to remember that cervicitis can be present without symptoms, or with symptoms so mild that the woman may not seek medical care.

#### *Sign*

Discharge from the vaginal or cervical opening which may vary from thin to thick and from clear, colourless to yellow, green or white.

**Symptoms**

- Vulvo-vaginal irritation
- Vaginal soreness
- Pain on intercourse

**Causes**

*Vaginitis* may be caused by:

- *Trichomonas vaginalis*
- *Candida albicans*
- Bacterial vaginosis

*Cervicitis* may be caused by:

- *Neisseria gonorrhoeae*
- *Chlamydia trachomatis*

**Flow chart**

There are three flow charts 43.1, 43.2 and 43.3 for vaginal discharge depending on whether speculum examination is possible or not and whether microscope is available. Conditions where a speculum examination may not be feasible are:

- The client refuses to be examined
- Lack of private space, gloves, a table, or sufficient light
- Lack of vaginal speculum

Following are the conditions where vaginal speculum examination is feasible:

- Sterile speculum is available
- There are gloves and a table with a good light
- The health worker has the expertise
- The client agrees

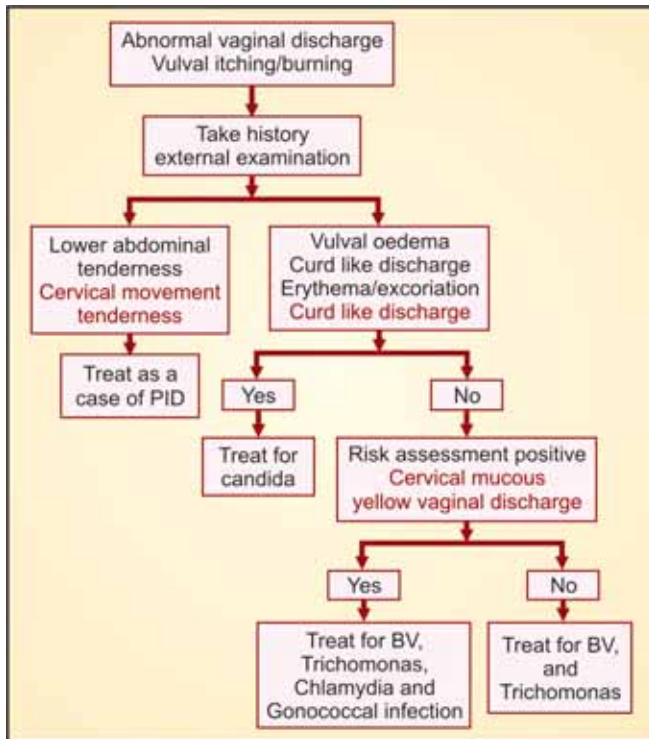
(Examination with speculum can distinguish between vaginitis only and those with vaginitis and cervicitis).

This examination requires a degree of clinical experience and acumen. The clinician must be able to introduce a speculum, expose the cervix and decide whether evidence of cervicitis is present. The best indication of this is white or yellowish discharge coming out of the cervix. It is often difficult to be sure that any discharge is arising from the cervix and not from the vagina. To ascertain this, the cervix should be cleaned and one should see if discharge is coming from the actual opening of the cervix. If speculum is available use Flowchart 43.2. If microscope and trained personnel are available use flow chart 43.3 for management.

**Treatment**

- The syndromic treatment for vaginal discharge will be in all cases — treat for vaginitis (trichomoniasis and BV plus candidiasis)
- In some cases — if the risk assessment is positive and/or discharge from the cervix is detected, give treatment for cervicitis (gonorrhoea and chlamydial infection)

**Flow chart 43.2:** Speculum and bimanual



**Treatment Guidelines**

*For Gonorrhoea (gonococcal urethritis/cervicitis):* Cefixine 400 mg. orally single dose or Ceftriaxone 250 mg. IM single dose plus treatment for non-gonococcal urethritis or cervicitis.

*For Chlamydia (non-gonococcal urethritis or cervicitis):* Azithromycin 1 gram, orally single dose or Doxycycline 100 mg. orally twice a day for 7 days or Tetracycline 500 mg. orally four times a day for 7 days.

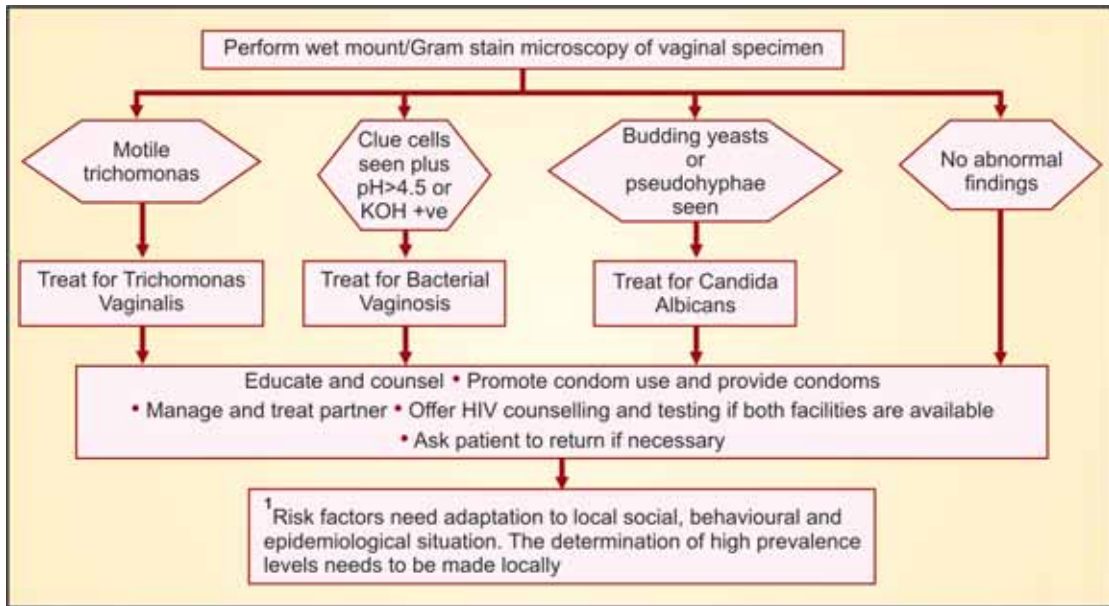
*If pregnant:* Erythromycin 500 mg. orally four times a day for 7 days.

*For Trichomoniasis:* Metronidazole 2 grams orally single dose Metronidazole 500 mg orally twice a day for 7 days.

*Note:* Do not use in the first trimester of pregnancy

*For symptomatic relief:* Clotrimazole 100mg Vaginal Suppository for 7 days.

Flow chart 43.3: Vaginal discharge bimanual, speculum and microscope



## Bacterial Vaginosis

*Metronidazole*: 500 mg. orally twice a day for 7 days or Metronidazole 2 grams, orally single dose.

*First trimester of pregnancy*: Clindamycin 300 mg orally twice a day for 7 days.

*For Candidiasis*

- Clotrimazole 500 mg per vagina single dose or
- Miconazole 400 mg per vaginum each night for 3 days.

4Cs i.e. Counselling, Condom, Contact tracing and Compliance with treatment are an important part of the syndromic approach. Syndromic management can be used only with people who have symptoms and signs of an STI/ RTI. It is not an appropriate screening tool for people who are asymptomatic. If there are no symptoms or signs, there is no syndrome on which to base diagnosis and treatment.

## Advantages and Limitations of Syndromic Management

*Advantages of Syndromic Management*

- *Immediate treatment*: Clients receive diagnosis and treatment in a single visit

- *Effectiveness*: Clients are treated for a potential mixed infection. The use of flowcharts with appropriate treatment recommendations reduces the chance of ineffective treatment. This approach helps to prevent incorrect diagnoses in settings where clinical diagnosis is common
- *Ease of use*: It is easy to teach and learn, so all levels of health care providers and facilities can use it. It requires good training, but not specialised knowledge about RTIs
- *Low costs*: There are cost savings since expensive laboratory tests are not used.

*Limitations and Concerns*

- *Limitations in diagnosing vaginal discharge*: Vaginal discharge poses a particular challenge since the syndrome might not be related to an STI. Because of the potential for negative reactions from clients and partners when the infection may not even be caused by an STI, it is important to consider each case on an individual basis. Women who do not have STIs but who have non-sexually transmitted RTIs that cause vaginal discharge may be told they should have their partners come for treatment; this can lead to relationship problems, including violence.

- *Potential for over treatment:* Clients are treated for multiple infections, although some will have no infection or only one. This is costly in terms of unnecessary drug use, waste of drugs that could be used to treat other clients, and the potential for microorganisms to develop resistance to antimicrobial drugs.
- *Ineffectiveness against asymptomatic infections:* This approach cannot be used with clients who are infected but show no signs and symptoms.
- *Need for data:* Algorithms, risk assessment tools, and treatment protocols should be based on information that is difficult to collect in many settings, including disease surveillance data, studies of risk factors, and microbial resistance tracking in the geographic location where the syndromic approach is being used.

### When Should Syndromic Management Be Used?

Syndromic management is effective and recommended for use in:

- Men with urethral discharge
- Women with lower abdominal pain
- Men and women with genital ulcers

Advantages outweigh disadvantages for these three syndromes.

### Role of Syndromic Management in Vaginal Discharge

Several problems with syndromic management limit its utility in women with vaginal discharge since this syndrome may be related to either vaginitis or cervicitis. Studies have shown that syndromic management is only slightly better than random treatment in predicting cervical infection (infection with chlamydia, gonorrhoea, or both). Because gonorrhoea and chlamydia are so often asymptomatic, syndromic management will not have a significant impact on their prevalence. Vaginal discharge is much more often due to vaginal infections than the more serious cervical infections caused by STIs; therefore, using the syndromic approach results in over treatment for many women who do not have an STI. In addition, telling a woman she is being treated for an STI when she may not have one raises serious concerns in terms of partner management and potential relationship problems, including domestic violence.

However, despite the concerns and disadvantages of syndromic management for vaginal discharge, in settings

where appropriate laboratory diagnostic services are not available, some form of syndromic management is the only option for women who present with this syndrome. This is a major unresolved issue in the field.

In settings where the prevalence of gonorrhoea and chlamydia is low, algorithms may be modified to treat for vaginal infections only. In settings where clients are likely to be able to return to the clinic for repeat visits, a two-step process to address vaginal discharge can be tried. Women are first treated for vaginitis, and then if the symptoms do not resolve, they are treated for cervical infections.

### Syndromic Approach: India

#### *Prevalence and Effectiveness of Syndromic Approach*

Thakur *et al* studied all women in the reproductive age in a rural setting in Chandigarh, and found a prevalence of 17.6 per cent for vaginal discharge. This prevalence rate is comparable to a study of slum women in Chandigarh. In a study among commercial sex workers in Calcutta, vaginal discharge was found in 48 per cent cases, which may be due to high-risk behaviour. Majority of women tolerate vaginal discharge of varying degrees for a long time before they consult a doctor; overall consultation rate for RTIs is quite low. A consultation rate of 45 per cent was reported for slum women of Chandigarh. Reasons for low consultations were illiteracy, simply ignoring the symptoms due to lack of concern and awareness for the problem, or shyness regarding a symptom pertaining to private parts. Bang *et al* reported that 92 per cent women in their study had one or more gynaecological or sexual disease but only 8 per cent of them had a gynaecological examination in the past even though 55 per cent were aware of having some gynaecological disorder.

Treatment using the WHO syndromic approach was advised to all patients in Thakur's study, but only 65.9 per cent came forward despite two home visits. Only 65.9 per cent took complete treatment and 83.4 per cent of them were cured of their symptoms, which is comparable to results from two Rwandan towns. The main reason for partial treatment was financial cost (58%) and perceived side effects (29%). Only 30 per cent spouses came forward for treatment.

Ranjan *et al* evaluated the WHO diagnostic algorithm for RTIs in 300 married women. The prevalence of RTIs was 37.0 per cent by syndromic approach based on

symptoms, 51.7 per cent by clinical examination and 36.7 per cent by microbiological laboratory investigations. The overall prevalence of RTIs by laboratory investigations was 36.7 per cent. Prevalence of candidiasis was highest (26.3%) among all infections diagnosed, followed by vaginitis (18.0%), trichomoniasis (15.7%) and bacterial vaginosis (14.3%). They found the sensitivity and specificity of syndromic approach to diagnose any RTI was 53.6 per cent and 72.6 per cent respectively while clinical examination had 68.2 per cent sensitivity and 60.5 per cent specificity. Overall clinical examination had relatively high sensitivity but low specificity. For trichomoniasis and bacterial vaginosis the clinical examination had low sensitivity but a high specificity.

Vishwanath *et al* found the algorithm based on risk assessment and speculum examination was not helpful in predicting cervical infections associated with *C. trachomatis* (sensitivity 5% and PPV 9%). This algorithm was sensitive (95%) though not specific (22%) in diagnosing bacterial vaginosis or trichomoniasis and over treatment was a problem (PPV 38%). The sensitivity, specificity and PPV of this algorithm for the diagnosis of candidiasis were 48 per cent, 98 per cent and 88 per cent respectively. A study by Nandan *et al* observed an improvement in the sensitivity (81.8%) and a predictive accuracy (74.1%) in the diagnosis of RTI by clinical examination as compared to the syndromic approach.

### Operational Aspects

The management services for RTIs/STIs as vertical programmes have been implemented in India and are variably effective. These services must be delivered through the primary healthcare system, building whenever possible on the existing resources, health providers, and programmes. Existing facilities require privacy, instruments, and logistics for consultation and examination of RTIs. A study on operational aspects in Bangladesh showed that doctors were more inclined to clinical diagnosis and treatment, while the paramedics always followed the recommended steps of syndromic management. The providers did not mention any specific

problem in adopting the syndromic management flowcharts, but often the line of treatment was not as per the flowcharts. The paramedics expressed the need of job aids in relation to diagnosis and treatment, which they can instantly go through even in the presence of a client. In 22 per cent of the cases, the providers did not prescribe drugs according to the technical standard guidelines they followed. Hence, training for healthcare providers is usually required when providing RTI clinical care through a syndromic- based approach. Such training should be targeted at medical officers, nurses (paramedics) and medical assistants.

### Vestibulitis

This may be primary or secondary, depending on whether the woman always had the introital discomfort on intercourse or insertion of a tampon, or whether it started after a period of pain-free intercourse. Some women have discomfort at rest. Urinary symptoms of incontinence, urethral syndrome, interstitial cystitis or symptoms of the irritable bowel syndrome may be present.

The aetiology is unclear. All organisms which cause vaginitis have been implicated but none has been proved to be causative, including *Candida* and human papillomavirus (HPV), though many patients date their problem to an attack of one of these. Calcium oxalate crystals in the urine may aggravate the condition in some. Neural hyperplasia has been demonstrated but can be present in other chronic inflammatory conditions as well.

Treatment is essentially symptomatic. The patient is advised to avoid the use of soaps, creams, and other irritants and to wash the area with water after voiding. Local application of non-irritating emollients such as vegetable oils is soothing. Zinc oxide also protects the vulva. Surgical treatment may be essential in some patients. Total vestibulectomy (perineoplasty), vestibuloplasty and local excision have all been used with long-term success rates of about 80 per cent. Simple disruption of innervation by incision or undercutting without excision of painful tissue or increasing the size of the introitus is ineffective.

# CHAPTER 44

## Low Backache and Chronic Pelvic Pain

General Considerations	676
Causes in the Genital Tract	676
Extragenital Causes	677
Management and Treatment	678

### GENERAL CONSIDERATIONS

Low backache more often affects women than men and this leads to the assumption that its cause lies in the female genitalia. The sex difference incidence, however, is mainly explained by the fact that the female muscular and ligamentary supports are not as strong as those of the male and, under conditions of civilisation, are disused or ill used, yet are still exposed to the stresses imposed by pregnancy and by the poor posture associated with many occupations favoured by women. So common is the symptom that when a woman complains of backache it is all too easy to assume that it is at the lumbosacral level. In fact, if a proper enquiry is made, it will not infrequently be found that the pain is in the dorsal region or over the coccyx. Coccydynia can follow injury sustained during the second stage of labour. The idea that low backache is often caused by a gynaecological lesion is encouraged by the fact that it is invariably worse before menstruation and it often dates from pregnancy, labour or the puerperium. During pregnancy the mobility of the pelvic girdle exposes the muscles and ligaments to unusual strains and, in the later weeks, they also have to maintain the physiological lordosis. After delivery, some time elapses before the joints become stable and before the stretched ligaments and muscles involute. Meanwhile, the woman is exposed to additional physical work, including prolonged bending over the sink, lifting the baby and struggling with a pram or stroller. Not only has she not recovered from the physical strain of pregnancy; she is subject to the considerable nervous and emotional stresses of motherhood and has inadequate rest and sleep. An anxiety state is therefore likely to exaggerate symptoms of physical disability.

### CAUSES IN THE GENITAL TRACT

Any backache caused by a gynaecological lesion is always diffuse. It is situated in the midline or has a bilateral distribution. Its level is sacral or lumbosacral and never higher than the fourth lumbar vertebra. Any backache which can be indicated with a finger point, or which is associated with local tenderness, is not due to an intrapelvic lesion.

Gynaecological conditions which *may* cause backache are the following:

### Prolapse and Retroversion

*Vaginal* prolapse never causes backache; *uterine* prolapse and retroversion *may* on rare occasions do so by dragging on the uterosacral and cardinal ligaments. Backache caused by uterine prolapse is immediately relieved by lying down, a crucial point in diagnosis.

### Chronic Cervicitis

This is a debatable cause of backache. It probably only operates when there is associated gross scarring and chronic cellulitis in the adjacent ligaments. Backache with such a basis is improved but is not completely relieved by rest. A cervical erosion *never* causes backache.

### Tumours

A large abdominal tumour may cause backache because the muscles of the trunk have to support the added burden, as well as maintain the lordosis necessary for the patient's balance. A tumour impacted in the pelvis can cause a sacral ache associated with deep pelvic discomfort. Sacrococcygeal teratomas may present with low backache.

Infiltration of the uterosacral ligaments by endometriosis, by a malignant extension from the cervix or any other site, causes low backache; when the sacral plexus becomes involved the pain is referred down the back of the leg.

### Pelvic Congestion; Pelvic Varicocele; Premenstrual Syndrome

Slight discomfort low in the back is so common premenstrually that it is regarded as one of the normal menstrual molimina; it becomes exaggerated with pelvic congestion and in the premenstrual syndrome.

### Uterine Contractions

Expulsive uterine contractions, or cervical resistance to them, can cause pain over the area of the sacrum. This can occur, for example, during labour, abortion and attempts to expel polypoid growths, pus and blood from the uterine cavity. It is also a feature of spasmodic dysmenorrhoea. Nevertheless, this type of discomfort is subsidiary to the accompanying abdominal pain and does not come under the heading of what is usually meant by 'low backache'.

### Gynaecological Operations

Gynaecological operations not infrequently cause sacroiliac strain or other forms of low backache. These complaints follow the use of the lithotomy position or prolonged lying on a flat table with relaxed muscles. To avoid injuries in the first position, it is important to raise and lower *both* legs at the same time; in the second position the lumbar curve should be maintained by a special pillow.

Postoperatively, lying in a sagging bed can result in backache of muscular or ligamentary origin.

The conclusion is that, contrary to what was formerly believed, and still is in some quarters, pelvic lesions are rare and unimportant *direct* causes of low backache in women, accounting for only 0.2 per cent of such complaints. The fact that operative treatment for pelvic conditions is sometimes followed by the relief of backache does not establish a cause-and-effect relationship (*see below*). Indeed, the only reasonably certain gynaecological causes of low backache are malignant, inflammatory and endometriotic infiltration of pelvic cellular tissue and uterosacral ligaments, together with spinal metastases from pelvic cancer.

The woman who complains of backache nearly always has something wrong with her back.

## EXTRAGENITAL CAUSES

### Muscular and Ligamentary Lesions

The possibilities under this heading are numerous but many are merely names without proven pathology. Those deserving mention are lumbago, fibrositis, myositis, acute or chronic strains of the attachments of muscles and ligaments, rheumatic conditions and sacroiliac strain. In all cases the pain tends to be localised and accompanied by tenderness; sometimes it is one-sided and often it extends higher than the lumbosacral region. It is worse premenstrually and during pregnancy, and shows a definite relationship to exercise, rest, position, and movement of the trunk. Sacroiliac strain and 'fibrositis' are often worse in bed; the former is related especially to lying flat on the back and to rotatory movements of the trunk.

Sometimes there is a history of injury or strain but often there is not. Minor repeated trauma is commonly accounted for by obesity, bending and lifting, poor posture, pendulous abdomen, visceroptosis, flat feet,

badly designed shoes with high heels (which increase the already relatively high angle of inclination of the pelvis), and long hours at the wheel of a car or an office desk.

Many of the above conditions are characterised by spasm of muscles, or groups of muscles, and it is suggested that the spasm may be the cause rather than the effect. This is one of the justifications for treatment by the injection of local anaesthetics at the site of the pain.

Lumbago and other pains are sometimes caused by disc prolapse rather than by a disorder of the muscles and ligaments.

### Bone and Joint Lesions

Deep-seated causes of backache include arthritic conditions of the spine, disc lesions, tuberculosis of bones and joints, primary and metastatic growths, ankylosing spondylitis, osteitis deformans, bone injuries, spondylolisthesis, spondylitis, sacralisation of the fifth lumbar vertebra, scoliosis, kyphosis and degenerative changes associated with ageing. Many of these lesions involve nerve roots and cause pain referred down the back of the leg. Otherwise pain and tenderness tend to be localised and often they are worse immediately after rest, easing as the joint works loose with movement.

### Diseases of The Kidney and The Ureter

Renal pain is usually unilateral and its characteristic site and distribution make it comparatively easy to identify.

### Diseases of The Rectum

Carcinoma or any condition of the rectum producing spasm can cause sacral discomfort or a sensation which the patient calls backache.

### Psychological Factors

In the majority of cases of low backache in women a gross lesion is not found and an obvious cause is not demonstrated. Patients tend therefore to be handed from physician to gynaecologist to orthopaedic surgeon, and back again. No one is willing or anxious to take responsibility for the case and, sooner or later, the complaint is ascribed to anxiety neurosis or other psychological disturbance. It is undoubtedly true that many of the sufferers from chronic backache are of over-anxious and complaining disposition. Nevertheless, even

in these there is likely to be an organic basis for the localisation of their complaint.

### MANAGEMENT AND TREATMENT

The essential step in the management of low backache is to determine its cause by meticulous enquiry into the features of the pain (Flow chart 44.1). These include its mode and date of onset, its exact site and spread, and its relation to rest, lifting, bending and other movements of the trunk. The discovery of local tenderness over a joint or muscle attachment during examination is also significant.

Apart from pelvic examination, radiography of the spine and pelvis is required in all cases, with the object of excluding major disease of bone rather than providing the diagnosis. In most cases, sometimes even when there is a disc lesion, the radiological findings are negative. Magnetic resonance imaging (MRI) is useful in evaluating such cases.

The treatment depends on the cause but, when a definite lesion is not found, the main requirements are reassurance and understanding, correction of posture, a well-fitting corset, abdominal and spinal exercises, appropriate footwear and advice about organising life to provide interest and periods of rest. In the more serious cases an orthopaedic surgeon may decide to give local injections of anaesthetic solutions, to manipulate joints or to give other forms of treatment.

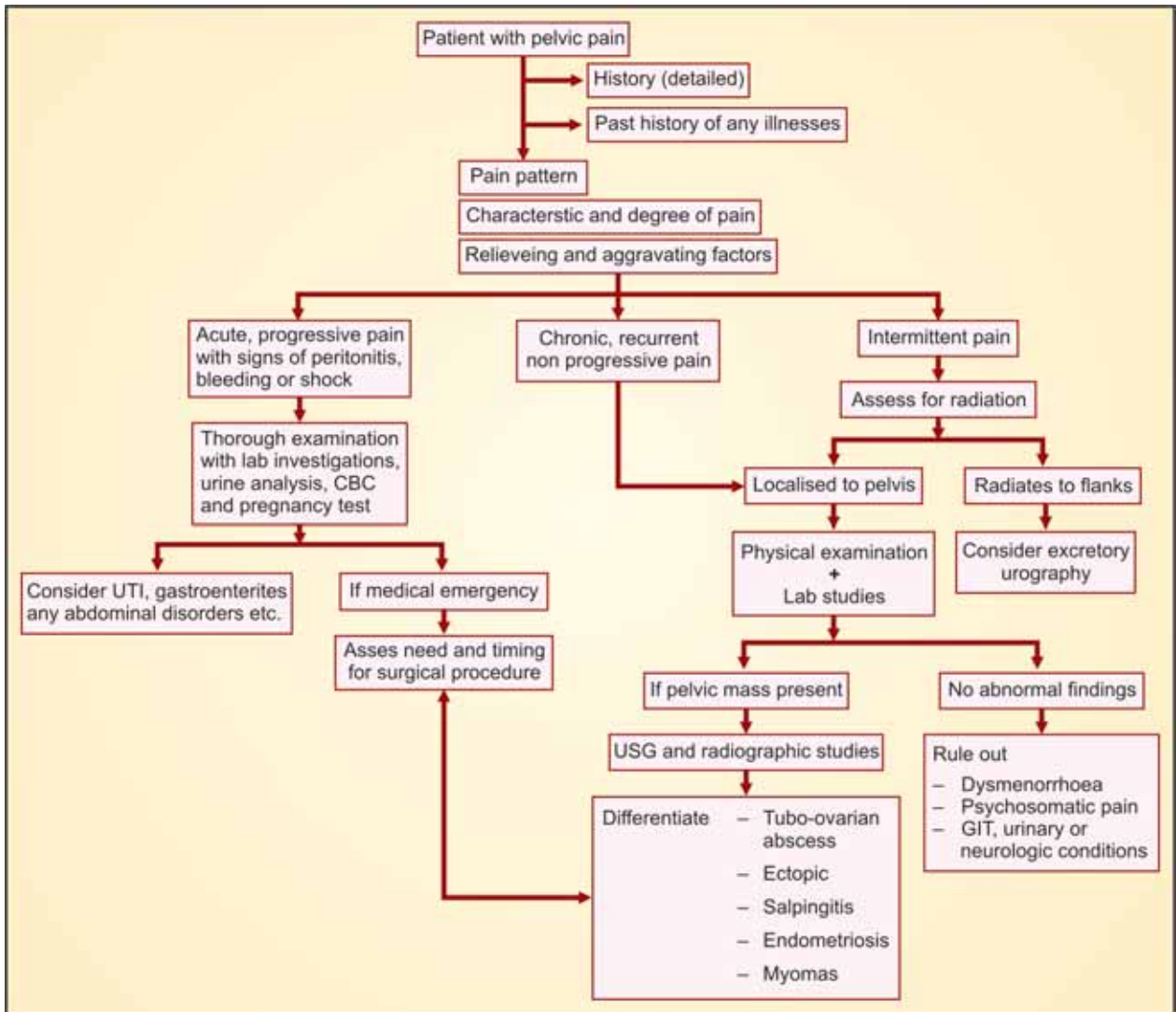
The response to treatment in any case can easily lead to false conclusions. For example, a woman may be treated surgically for prolapse or for an erosion of the cervix and thereafter be cured of her backache — for some time at least. It is then tempting to conclude that the backache was caused by the pelvic condition. More careful observations will, however, often make it clear that the operation cured only because it ensured that the woman had a period of prolonged rest, care, sympathy and relief from domestic duties.

### Chronic Pelvic Pain

About 10 -15 per cent of women have chronic pelvic pain with or without back ache. Patients with chronic pelvic pain are frequently anxious and depressed. Anywhere from 20 to 80 per cent of patients undergoing laparoscopy for chronic pelvic pain have no intraperitoneal pathology or have tissue distortion that does not correlate with the pain, certain types of prevalent intraperitoneal



Flow chart 44.1: Stepwise assessment



pathology, such as endometriosis, adhesions, or venous congestion. Non-gynecologic causes of pain, such as irritable bowel syndrome, interstitial cystitis, abdominal wall or pelvic floor myofascial syndrome, or nerve entrapment, are frequently overlooked but common causes of chronic pelvic pain.

*Evaluation*

The patient should be questioned about symptoms specific to the types of pathology:

1. Genital (abnormal vaginal bleeding, discharge, dysmenorrhoea, dyspareunia, infertility)

2. Enterocolic (constipation, diarrhoea, flatulence, haematochezia, and relationship of pain to bowel movements)
3. Musculoskeletal (trauma, exacerbation with exercise, or postural changes)
4. Urologic (urgency, frequency, nocturia, dysuria, incontinence, haematuria)

A complete physical examination should be performed, with particular attention directed to the abdominal, lumbosacral, external genital, vaginal, bimanual, and rectovaginal examination.

A thorough patient history is one of the most helpful tools in the evaluation of patients with CPP. The **COLDERR acronym** may be used to gain a general understanding of the patient's history of present illness.

**Character**—What does the pain feel like? (sharp, dull, crampy)

**Onset**—Does the pain come on suddenly or gradually? Is it cyclic or constant?

**Location**—Is the pain localised or diffuse?

**Duration**—How long has the pain been present and how has it changed over time?

**Exacerbation**—What activities or movements make it worse?

**Relief**—What medication, activities, and positions make it better?

**Radiation**—Does the pain radiate anywhere (back, groin, flank)?

Investigations needed may be ultrasound, diagnostic laparoscopy, Doppler ultrasound for pelvic congestion, radiography of joints, IVP in accordance with history and examination.

If ultrasound is not showing any abnormality then a diagnostic laparoscopy is recommended if other somatic

causes are ruled out and the results of the psychological evaluation are negative.

### *Management*

A multidisciplinary therapy by gynaecologist, psychologist and an anaesthetist is usually preferable in patients with no obvious pathology. The overall effect seems to be good with a low dose of a tricyclic antidepressant which is combined with behavioural therapy directed towards reducing reliance on pain medication. Psychotherapy is indicated for women who have pronounced depression, sexual difficulties, or indications of past trauma.

Antioestrogens reduce blood flow and suppress ovulation so pain due to dilatation of pelvic vessels is reduced. Medroxyprogesterone acetate can be given for 9 to 12 months. Micronised progesterone is a natural progesterone available as oral and vaginal tablet.

It can be given once a day in premenstrual phase. Other drug under trial is — Diethylergotamine which has shown to reduce the severity of pelvic pain in 48 hours of IV injection.

If drug therapy fails then hysterectomy may be resorted with bilateral salpingo-oophorectomy.

# Problems of Sex and Marriage

Physical Sex-coitus	682	Coital Difficulties in the Male	692
Masturbation	685	Homosexuality	695
Apareunia and Dyspareunia	685	Transvestism and Trans-sexuality	696
Female Frigidity	688	Premarital Chastity and	
Premature Orgasm	691	Faithfulness in Marriage	697
Nymphomania	691		

## INTRODUCTION

Sex is one of the three basic human instincts and is therefore strongly developed in the normal individual. Its influence on behaviour is controlled to a large extent by environment, and especially by the laws, customs and outlook of a particular community which determine celibacy, promiscuity, marriage, monogamy, polygamy, polyandry and the like. The rules of society governing sexual conduct change from time to time.

In the human being, sex is an emotional as well as a physical experience and is evident to some extent in early childhood; baby girls, for example, soon show an interest in appearance and dress, and in boys. Later childhood is generally a mainly asexual phase although homosexual and heterosexual love play is not uncommon at this age. Adolescence normally reveals a homosexual urge such as the violent affection which one girl has for another girl or woman, and the hero worship exhibited by a boy for an older boy or man. This is quickly replaced by heterosexual impulses which become deeper and more serious as maturity is reached and which usually culminate in marriage, home-building and child-bearing.

The ages at which these events occur are changing, being determined by a tendency to earlier maturation and by a desire to conform to group behaviour. In western communities, at least, girls aged 12-13 years now often have strongly developed heterosexual interests. By the age of 15 years, and if only as a status symbol, many are 'going steady' with a particular boyfriend. While a large percentage are married by the age of 20 years, there is also an increasing number of premarital and *de facto* relationships.

In India, the legal age of marriage is 18 years. In rural communities, the majority of women have had arranged marriages and possibly borne children by this age, but in the urban upper classes, with the benefit of education, marriage is often postponed till the age of 23-25 years, or until the woman is professionally established.

There are some who regard companionship as the basis of marriage. The majority, however, accept marriage as essentially a sexual partnership with

reproduction and a stable family life as its main objectives. It is, however, a partnership in which sexual acts are a demonstration of lasting affection rather than the satisfaction of a passing lust. The important feature of marriage is its permanence and this in itself gives a sexual satisfaction which is not usually obtained from a fleeting *affaire*. Moreover, good sexual adjustment between the partners ensures permanence because it is strong enough to override the tiffs and quarrels which are inevitable between even the closest companions.

Unfortunately, sexual disorders and maladjustments are common and are the cause of much marital disharmony and divorce. On the other hand, it must be recognised that these difficulties are sometimes the result rather than the cause of incompatibility. The successful medical handling of disorders pertaining to sex cannot be taught by precept; it is largely dependent on experience of life and comes with age and personal observation. The family doctor is usually the best placed for dealing with sexual and marital problems, but some patients find it easier to tell these troubles to someone less well known to them. Whoever it is should generally interview both husband and wife but should see them separately as well. The manner which encourages confidence and removes embarrassment is neither shy nor hearty; it is scientific, dispassionate and uncritical.

### PHYSICAL SEX - COITUS

#### The Art of Coitus

The object of heterosexual attraction in the adult is to bring the male and female into pleasurable physical contact which leads ultimately to sexual intercourse and to reproduction. The human sexual response has three major components — desire, arousal and orgasm. A woman attracts by facial appearance, curved figure, behaviour, stance, walk, voice, adornments and by mental qualities. The male's attractions are less easy to define but manliness in manner and behaviour takes precedence over looks, figure, intelligence, and economic and social status. An important feature of sexual desire in the man is the urge to dominate the woman and subjugate her to his will; in the woman acquiescence to the masterful still takes a high place, although this is now debatable in some western countries. Choice of a mate in human society is not governed by hormones so much as by the brain which is selective according to mental as well as physical attributes. Indeed, although it may not

be obvious, the mind usually rules the heart, and it does so by impulses arising mainly in the temporal lobes and transmitted through the hypothalamus. Coitus is the culmination of various forms of sexual contact. Many areas of the body are erogenous, that is, capable of giving rise to a pleasurable erotic sensation when stimulated by touch. In the woman these include the lips, tongue, back of the neck, shoulders, breasts, buttocks and thighs as well as the genitalia. Kissing, fondling, petting and love play are natural preludes to coitus. In the female they stimulate the secretions of Bartholin's glands and bring about relaxation of the introitus; in the male they cause erection of the phallus. In both, if carried to extremes, they can themselves result in orgasm. Orgasm is the all-possessing physical pleasure which represents the climax of physical love. In the man it is accompanied by emission of semen, in the woman by rhythmic contractions of the muscles around the vagina. It does not cause dilatation of the cervix as is sometimes alleged. Orgasm is followed by immediate relief of nervous and physical tension with pleasurable lethargy and sleepiness.

In the woman, sexual feelings are dormant as compared to those in the man and develop with experience. Extragenital erotic sensations come easily but the desire for coitus and pleasure from it are acquired later. Orgasm from stimulation of the external genitalia (*clitoridal orgasm*) usually appears before *vaginal orgasm*, but the latter is more intense. This natural evolution is reproduced in each sexual act and, unless the male guards against it, he experiences orgasm more quickly than his mate. Indeed, it is the male who ordinarily teaches the female the art of coitus and he does so by making it merely one part of the act of making love. With increasing experience a couple quickly adapt themselves to each other so that orgasm is achieved simultaneously. Moreover, they increase their mutual pleasure by variations in technique and by postural changes.

Some women never achieve vaginal orgasm and always depend on stimulation of the clitoris, vulva and extragenital erogenous areas for satisfaction. Indeed, one view denies the existence of the phenomenon of vaginal orgasm and postulates that female orgasm is always 'clitoridal' in type. This argument is in line with the established relative insensitivity of the vagina to physical stimuli but most women with satisfactory sex lives have no doubt that vaginal orgasm is real and much more powerful than that induced by superficial stimulation.

This is thought to be related to a G spot which has been identified inside the vagina and which is extremely sensitive to deep pressure. It lies in the anterior wall about midway between the symphysis and the cervix, near the bladder neck.

The above views, long established and confirmed by the experience of nearly all normal women, are an anathema to pressure groups agitating for the liberation of women and equality of the sexes in all matters. They protest that the concepts of masculine initiation of sexual activity, and of the need for the female to be aroused by her mate, reflect the prejudice of males in general and of male gynaecologists in particular. Such protagonists maintain that sex drive and desire are spontaneously just as strong in girls and women as they are in boys and men, being motivated by personal pleasure rather than by a procreational instinct or anxiety to satisfy their lover. Sex equality in many respects is desirable; but the value of sexual differences should not be underrated.

### The Consummation of Marriage

A marriage is not consummated until sexual intercourse has taken place. If the partners are virginal, the 'first night' generally proves a great disappointment. After the excitements and tension of the wedding day, and after much hard work in preparing for it, both are emotionally if not physically exhausted. Add to this embarrassment, nervousness and inexperience and a common result is premature ejaculation or impotence on the part of the male. If this does not occur, the entrance to the vagina proves narrower than expected, or the hymen is tough, or nervousness causes vaginismus, so penetration rarely takes place on the first attempt. The experience provides more pain than pleasure. If the bridegroom realises these problems and avoids pressing his attentions on the first night, as some books advise, the bride is offended that he can resist her attractions; if he suffers impotence, she concludes that he does not love her and he finds his self-confidence shattered.

The normal couple surmount these difficulties quickly, especially if they are prepared for them. Within a few days they find that partial coitus is possible, although 3 or 4 weeks may elapse before intercourse is complete and satisfactory. Indeed, it may be 1 or 2 years before the wife *regularly* experiences full orgasm.

After the first attempt at coitus the hymeneal edges and the introitus are usually bruised and sore; this is an

indication to wait a few days before renewing the attempts. So is the development of *honeymoon cystitis* which, contrary to some statements, is rarely a manifestation of infection of the female urinary tract with gonococci or *Trichomonas vaginalis* organisms. The frequency and dysuria which characterise this syndrome are nearly always the consequence of traumatic urethritis, this being caused by injury to the vestibule and external urethral meatus during attempts to make the penis enter the vagina. The symptoms subside of their own accord within a few days but a bacterial urethritis and/or cystitis can occur.

### Frequency of Coitus

The young healthy couple practise coitus once every 24 hours during the early weeks of marriage but, within 1 or 2 years, the frequency falls to the standard 'normal' of two to three times a week. After many years, and with advancing age and increasing responsibilities, coitus may be practised only once a week. Thereafter it varies with individuals and with circumstances but many couples aged 60-70 years practise coitus occasionally if not regularly. In all these matters the partners should follow their natural inclinations.

Ordinarily, sexual desire in the female shows no special relationship to the menstrual cycle.

### Coitus During Menstruation

Discussed in Chapter 5.

### Coitus During and After Pregnancy

Although it is often suggested that coitus be discontinued during the first 3 months and during the last 2 months of pregnancy, there is no contraindication to coitus if it is mutually desired at any stage in normal pregnancy. The alleged risks are abortion, premature labour and the introduction of bacteria to cause subsequent puerperal sepsis. These are theoretical and few women come to harm, provided that gentleness is observed. Coitus need therefore only be banned for a period of time when the woman has threatened to abort or has a history of habitual abortion or preterm labour.

During pregnancy, however, the woman rarely has much sexual desire because the fundamental object of coitus has been achieved and her mind is centred on the foetus *in utero*; a dominant progesterone influence may

also play a part, although a minor one. During later months, the husband too usually loses his libido.

The possible dangers of coitus too soon *after* delivery are puerperal infection, and injury to the soft and vascular vaginal walls. If the couple is desirous, coitus can be resumed 4 weeks after delivery — provided that the lochial discharge has ceased, and that vaginal and perineal tears have healed and are not tender, but the usual recommendation is to wait until 6 weeks.

### Continence

Many individuals, especially males, have the impression that continence is harmful physically; this is used as an excuse for premarital and extramarital contacts. All the evidence goes to show that continence in either sex has no ill effect whatsoever. In fact, healthy male adults who do not practise coitus usually experience nocturnal emissions; these are to be regarded as physiological outlets for a sex urge.

### The Annulment of Marriage

If a marriage has not been consummated it can be annulled by legal procedure. According to English law, the principles of which apply in most English-speaking countries, consummation requires 'ordinary and complete intercourse' but this has been variously interpreted by the courts. Emission of semen is not generally regarded as being essential to complete intercourse, but there have been isolated cases in which regular cohabitation over a long period has not been accepted as consummation because the male phallus was always covered with a condom or because coitus interruptus was invariably practised. The occurrence of pregnancy has been held not to be incompatible with non-consummation when it resulted from semen being deposited on the vulva or from artificial insemination (intrauterine insemination or donor insemination).

The grounds for annulment on the basis of non-consummation are male impotence; a physical or mental bar to coitus in either partner which cannot be corrected without unreasonable risk — in practice there is no compulsion to have even a minor corrective operation; and wilful refusal by one partner. The court of law may call for medical evidence and often appoints its own inspectors to examine one or both parties. Any medical report should concern itself primarily with an account of the physical condition as evidence of coitus having

taken place. When male impotence is alleged the findings are usually negative. They are often equivocal when it comes to the assessment of virginity in the woman, if only because she has probably used menstrual tampons or has already had treatment such as dilatation of the introitus in the hope of correcting the *apareunia*. The presence or absence of a hymen, *vaginismus* or a stretched vagina should, nevertheless, be recorded.

Other grounds for annulment of marriage which are of medical interest are when one partner suffers from a communicable form of sexually transmitted disease at the time of marriage; when, at the time of the contract, the woman is already pregnant by another man; and when one or other partner is unfit for marriage and procreation by reason of suffering from mental disease.

In these circumstances it is necessary to show that the innocent party was unaware of the facts at the time of marriage, and that marital relations ceased as soon as they came to light. Moreover, proceedings under these headings must be taken within a specified duration, usually one year of marriage.

### Rape

According to law, rape is defined as 'the unlawful carnal knowledge of a woman without her consent by force, fear or fraud'. Moreover, consent is no defence when the woman is an imbecile or when she is less than 16 years of age ("age of consent"). Carnal knowledge is usually interpreted as any penetration of the external genitalia, even the vulva, by the male phallus. Emission of semen is not a criterion. Rape is a legal diagnosis, not a medical one, but medical evidence may be of value to the courts. A doctor consulted by a woman alleging rape should examine her *as soon as possible* after the occurrence but only with her written consent and in the presence of a third party.

All observations made should be recorded clearly and legibly. A detailed history, including her previous medical history, should be taken and complete physical examination done. Evidence which may help to substantiate or refute her allegation include the following:

- The patient's detailed account of the happening
- Her emotional state
- The state of her clothing - whether it is torn, muddy or bloodstained
- The presence of bruises and other injuries in any site—special attention should be paid to the genitalia,

breasts, face and limbs. Marks of ligatures may be present on the limbs.

- The state of her finger nails
- The condition of the vulva, hymen, vagina and anus — haemorrhages may be present on the vulva, the posterior fourchette may be split, the vagina, hymen and perineum may be torn or bruised and the anus may be gaping, or show bruises or fissures
- Matting of the pubic hair, or staining of the clothing, with semen
- The presence of loose hairs which can be shown to be similar to those on the pubes of the accused man
- The microscopic demonstration of semen on the vulva, on clothing or on vaginal swabs
- The transmission of sexually transmitted disease.

With these points in mind appropriate specimens of clothing and hair, and material for histological and bacteriological studies from the vulva and vagina should be taken, labelled and submitted for expert examination. Spermatozoa have been found in vaginal swabs up to 6 days after the event, in the anus up to 65 hours, in the mouth up to 21 hours and in clothing or bedclothes until washed.

If the accused man is examined, the evidence to look for is the presence or absence of injuries and bruises, especially scratch marks, at any site; semen or spermatozoa on the phallus, urethral meatus and clothing; loose hairs around the genitalia which may prove to match those on the pubes of the woman; venereal infection.

## MASTURBATION

Young children of both sexes tend to handle their external genitalia, presumably finding it pleasurable.

In adolescence, sometimes even before the age of 10 years, the majority discover that manipulation of the phallus and surrounding parts arouses erotic sensations to the extent of producing orgasm. Ninety-five per cent of boys masturbate in this way at some time in their life and failure to do so indicates abnormality, or a rigid upbringing or religious education. Girls are rather less inclined but it is estimated that 60 per cent masturbate to the extent of producing orgasm; this is nearly always clitoridal or vulvar, rather than vaginal.

Although the practice of mutual masturbation as part of normal heterosexual love play continues, 'self-abuse' by individuals of either sex tends to disappear with advancing years, and especially when marriage offers a

more satisfactory outlet for the sex urge. Occasionally, maladjusted adults find they can achieve orgasm by masturbation when they fail to do so during coitus; this is sometimes true even for impotent men.

Masturbation conveys a sense of guilt and shame although there is no clear reason why it should. Except for this emotional reaction it is harmless, although folklore credits it with causing infertility, premature old age and all manner of evils. As a result of such ideas, many adults in later years worry over its youthful practise and require reassurance. Even medical authorities say that masturbation causes hypertrophy of the clitoris and of the nymphae, and congestion of the pelvic organs. Hence, it is blamed for menorrhagia and congestive dysmenorrhoea. There is no evidence to support such statements.

## APAREUNIA AND DYSPAREUNIA

### Definition

*Apareunia* is the inability to practise coitus; *dyspareunia* means that the act is difficult and painful or that penetration is incomplete. The difference is mainly one of degree and the term dyspareunia is often used to cover apareunia. Sexual unresponsiveness and dyspareunia are closely allied and one can result in the other. Indeed, it is sometimes difficult to decide which is the cause and which the effect.

Both partners are concerned in dyspareunia and, although the complainant is usually the wife, it can be the husband. This happens if he suffers from phimosis, or if the wife has a foreign body in the vagina or projecting from the cervix. Moreover, it is not uncommon for the wife to be blamed when the real trouble is male impotence. Even when the initial fault is one-sided, both partners ultimately become emotionally disturbed. Disparity in size between the male phallus and the vagina is often alleged by the woman; this is only a theoretical possibility because the normal introitus and vagina can always adapt themselves.

Some women who suffer dyspareunia omit, through embarrassment, to mention it unless asked a leading question. Ignorance, too, can result in failure to disclose apareunia, and one may see patients who have been married for many years without either partner realising that they have never had coitus other than coitus interfemora.

## Male Causes

### *Impotence*

This is failure to obtain or maintain erection of the phallus.

### *Anatomical Defects of The Phallus*

These may be developmental or acquired.

### *Extreme Obesity*

Obesity has to be very gross to prevent genital contact.

### *Ignorance*

Ignorance, clumsiness, lack of consideration and inexperience on the part of the male play a part in causing female errors such as vaginismus.

Too much consideration and lack of manliness are equally, if not more, important causes of such troubles.

## Female Causes

### *Physiological*

Unless preceded by gradual stretching of the hymen and introitus, or the regular use of menstrual tampons, the initial attempts at coitus are nearly always painful and difficult.

### *Inaccessibility of The Vulva*

This might result from extreme obesity and from a severe bilateral adduction deformity associated with diseases of the hips or legs. It is remarkable how these and similar handicaps are usually overcome by modifications of coital posture.

## Obstruction at The Introitus

### *A Thick and Tough Hymen*

This resists stretching or tearing (Fig. 45.1).

### *Inherent Narrowness and Inelasticity of the Vaginal Orifice*

This is more likely in women marrying late; it is seen particularly when ovarian function is absent and in lichen sclerosus of the vulva.

### *Scarring and Contracture*

These can result from operations, obstetrical injuries and burns. Perineorrhaphy and prolapse operation, in general, are common causes of dyspareunia. Dyspareunia is also reported after hysterectomy in some women, especially when a vaginal cuff has been removed.

### *Vaginismus*

This is the commonest and most important cause of dyspareunia. It is a condition of spasm affecting the sphincter vaginae and levatores ani muscles, especially the latter. The spasm may be so great that the lower vagina is practically closed and both husband and wife have the impression that there is an organic obstruction. It is a protective mechanism and, in severe form, is accompanied by spasm of the adductor muscles of the thighs so that even the vulva becomes inaccessible.

Vaginismus can affect parous as well as nulliparous women and is not always cured by pregnancy. It may be accompanied by sexual unresponsiveness although sometimes sexual desire is quite strong. It occurs whenever there is a tender organic lesion in the pelvis, but is generally a functional disorder seen in

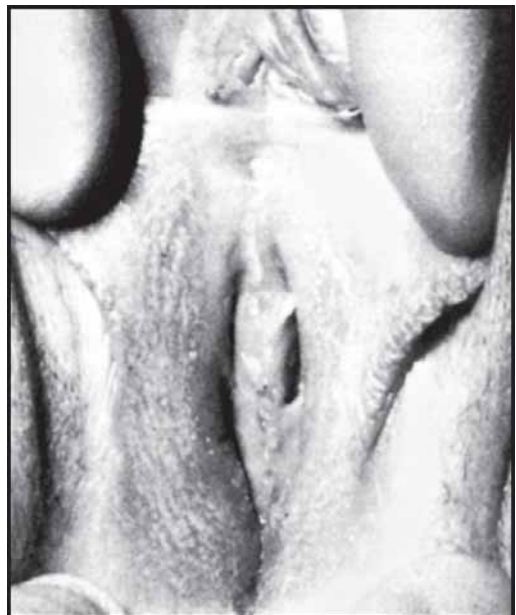


Fig. 45.1: A tough hymen with only a small eccentric opening which caused apareunia



the highly strung and overanxious woman who may be physically attractive but spoilt. Often her husband is over-considerate and lacking in virility. Other factors in its causation are faulty sex education; ignorance; initial painful and clumsy attempts at coitus; an unfortunate experience such as criminal assault; hysterical hyperaesthesia of the vulva and thighs; fear of pregnancy; fear of childbirth; and the use of contraceptives.

#### *Dryness of the Introitus*

Failure of Bartholin's glands to lubricate the vulva causes difficulty of entry and discomfort during coitus. This is a manifestation of sexual unresponsiveness, fear, or lack of oestrogen (that is, ovarian failure).

#### *Large Tumours of the Vulva and Lower Vagina*

These cause physical obstruction.

#### *Obstructions in the Vagina*

These include the following:

- Hypoplasia, including absence of the vagina
- Septa and membranes
- Shortness of the vagina. A deficiency in length can be developmental, or can result from plastic operations and from total hysterectomy. This cause of dyspareunia is subject to much dispute because it is incompatible with the generally accepted stretching capacity of the vagina.
- Adhesions and strictures following injuries, operations, vaginitis and senile change
- Large tumours.

#### *Superficial Painful Lesions*

- Tender scars in the vulva and vagina
- Infections: vulvitis, bartholinitis and infection of the lower vagina
- Haemorrhoids and fissure *in ano*
- Urethral conditions: caruncle, urethritis and acute urethral prolapse.

#### *Deep-seated Painful Lesions*

Except in its lowermost part, where its innervation is somatic, the vagina is insensitive so that vaginitis, ulceration and other lesions only cause dyspareunia when they involve the lower canal and the introitus.

Deep-seated dyspareunia never arises from the vagina itself but from paravaginal tissues and adjacent organs. This is true even of vaginismus in which the pain is the result of spasm in the paravaginal muscles. Such painful lesions are caused by:

- Cervicitis and fixation of the cervix by scars in the vaginal fornix
- Chronic cellulitis
- Salpingo-oophoritis
- Endometriosis, especially when it is situated in the rectovaginal septum and in the uterosacral ligaments
- *Retroversion*: The pain is caused by direct pressure on the tender uterus. It is more likely if the displacement is acquired than if it is developmental, and if it is fixed.
- *Prolapsed ovary*: If an ovary is pinned against some other structure during coitus it causes a sharp momentary pain with a sickening sensation afterwards.
- Tender lesions of the bowel, including spastic colon and even faecal masses in the rectum.

#### Diagnosis

The most important points in the investigation of a case are as follows:

- Exclude impotence or other errors in the male partner.
- Ascertain if the pain or difficulty is experienced at the introitus or whether it is high in the vagina. In this respect vaginismus is often described by the patient as a deep-seated obstruction.
- Ask if the pain is momentary or sustained and whether it is experienced at the time of coitus or later. If it persists for, or occurs, several hours later, its basic cause is always psychogenic. The patient is consciously or unconsciously finding an excuse to avoid coitus. 'Next day dyspareunia' is usually mediated by colonic and rectal spasm, although uterine spasm is also postulated. Backache occurring late after coitus has a postural explanation.
- Determine whether the dyspareunia is primary or secondary, and whether it dates from an operation, illness or childbirth.
- Look for a background of emotional factors and trace their origin if possible. Inquire particularly about sex education and experiences, the woman's attitude towards her husband and towards pregnancy, and the husband's attitude towards her and her

complaint. Nevertheless, psychogenic dyspareunia should not be diagnosed too readily.

- Pay attention to associated symptoms, especially those indicative of pelvic infection or endometriosis if the dyspareunia is deep seated.

### Treatment

The treatment of dyspareunia depends on the cause. Often nothing more than sex education of *both* partners is necessary. Fear of pregnancy may call for instruction in conception. Local organic disease is dealt with according to its nature. Occasional dyspareunia resulting from uterine retroflexion or a prolapsed ovary may be circumvented by advising the couple to alter their coital posture; only rarely is an operation needed for such conditions. Tender scars may need to be excised or stretched under anaesthesia. Sexual unresponsiveness demands attention, and it is reasonable to advise a water-soluble jelly when lubrication is defective.

In women without ovarian function the resilience of the vulva and vagina can be improved with oestrogens.

The common problem, however, is vaginismus associated with fear and hysteria; the treatment of this deserves detailed comment. The situation is first assessed by studying the patient's nervous make-up, her outlook on the problem and her reaction to a gentle attempt to make a one-finger vaginal examination. If it is clear that the patient is unlikely to cooperate, it is best to desist at once, to allay her fears and to explain that the entrance to the vagina is so narrow that it requires dilatation under anaesthesia. This operation is carried out to such an extent that the vagina will admit three fingers. As soon as the local tenderness has subsided, usually at the end of 48 hours, graduated glass or plastic vaginal dilators are passed by an experienced nurse or by the medical attendant. On the first occasion only the smallest size is used and the approach must be cautious. The real purpose of these instruments is not to dilate the vagina further but to convince the patient that her trouble is corrected and to give her confidence. Treatment is continued once or twice daily and the dilator left in position for 10-15 minutes on each occasion. When the largest-size dilator can be passed with reasonable ease, the patient is instructed to carry out the treatment herself and only when she can do this is she discharged from medical care. Even then she must continue using the

largest dilator regularly for 2-3 weeks before attempting coitus again. Instruction of the husband as to his approach at this stage is also important.

In many cases sexual counselling of the couple by an expert may be of more benefit than this mechanical approach. This may also be the case even if the woman and her partner are able to cope with dilators, since a psychological barrier to coitus may also be present. Each couple therefore has to be considered carefully and the most appropriate guidance or advice given. The success of any treatment depends almost entirely on the skill with which the patient is handled and, in this, persuasion, explanation, firmness and kindness all find a place.

In many cases the patient is less nervous, more reasonable and prepared to cooperate as an out-patient but time and patience are required. The woman is instructed first in sex anatomy and secondly in how to relax the pelvic floor muscles. A one-finger vaginal examination is then usually possible. Graduated vaginal dilators, well lubricated, are then passed and the patient is taught to use them herself until she is fully confident.

It is now fashionable to decry vaginal dilators as relics of the past and even to suggest that they may intensify unfavourable reactions to coitus. When skillfully used, however, they offer one of the simplest and most efficient means of overcoming a woman's fears and inhibitions, and of making her realise that any vaginal obstruction is of her own making.

As mentioned earlier, psychosexual counselling may also be used. One technique employed is to take the emphasis off coitus itself and to very gradually expand non-coital physical contact, only attempting coitus when all the previous stages are successful and enjoyable.

One method of dealing with introital difficulties is to enlarge the entrance to the vagina by making a median episiotomy, and then suturing it at right angles to the line of the incision (Fenton's operation). This is suited to the case in which the introitus is narrowed by scar tissue but is never necessary for functional dyspareunia.

### FEMALE FRIGIDITY

Frigidity means *absence of sexual desire (libido)* but the term is also used for failure to achieve orgasm. Although they often occur together, the two conditions are different.

## True Frigidity—Absence of Libido

### Aetiology

Understanding of the causes of frigidity depends on recognising the following:

- The psyche is the seat of libido.
- Ovarian function plays some part but is not essential to sex urge in the human being.
- Sexual desire is often not as strong in women as in men, and has to be aroused.
- Except when frigidity is secondary to dyspareunia it is *never* accounted for by an organic lesion in the pelvis.
- Frigidity is *nearly always* explained by constitutional, psychological and environmental factors, such as the following:

### Physiological

#### Age

Frigidity is normal in youth before arousal, and in later life when it is part of the ageing process. In 60 per cent of women sexual desire *begins* to wane before the menopause and in another 20 per cent soon afterwards; but this does not mean that it disappears; the majority of married women are still practising coitus regularly, if less frequently, at the age of 60 years.

#### After Pregnancy

For a variable period after childbirth, nearly all women lose sexual desire. This is partly because they are overtired and harassed, but mainly because the primary objective of coitus is achieved and their interests and affection are concentrated on the newly born baby. There is also an endocrine effect, particularly if the woman is breastfeeding and amenorrhoeic. Maternal instinct temporarily overrides the sex instinct. As the baby grows and shows signs of independence, and as the mother's general well-being improves, libido returns. There may also be psychological factors present, related to self-perception of being less attractive if weight increase, scars or striae are present. Most men, although delighted with the baby, are subconsciously jealous of it, especially when it is the first. They realise they are no longer the sole object of their wife's affections and that their physical comforts are of secondary importance. Secondly, at the same time, a husband's advances are repulsed, he is first

puzzled and then hurt; the wife, on the other hand, accuses him of lack of interest in the baby and turns to her mother. Thus are set the seeds for marital breakdown. To avoid this, explanation and masculine patience are necessary during the few months which it takes for the family unit to readjust itself.

### Constitutional

A wide variation in the inherent strength of the sex instinct, which may vary with time and circumstances, must be accepted; individuals have different appetites for coitus as they have for food, music and games, and nothing can alter this. It may be that some are inherently devoid of any sexual feeling but these are rare; in most women, libido of some degree can be aroused given the proper circumstances and the right man. Some women with weak sex drives choose or have to accept circumstances which depress rather than stimulate any urge which they may have. They either marry an undersexed man who gives them little stimulus and encouragement, or they remain unmarried and direct their interests into other channels.

Most of the following aetiological factors may be important in those who appear to have a weak sex drive or libido. *A strong instinct or change of circumstance may surmount them.*

### Early Impressions

Frigidity can reflect a puritanical upbringing and inculcation with ideas that men are hateful, that sex is sinful and that coitus is merely a wifely duty. The widowed or divorced mother of an only child sometimes wilfully or subconsciously conditions her daughter against sex and men in order not to lose her by marriage. Childish and adolescent experiences of an unhappy household, of interference with the genitalia and lower bowel, of masturbation and of homosexual practices, can induce a subsequent inhibition of the sex urge.

### Lack of Deep Affection for Husband

Causes under this heading are closely allied to those mentioned above. The only daughter acquires a father fixation, the only child sometimes a mother fixation, and they may find it impossible to transfer any deep affection. Some women who are physically attractive, smartly dressed and spoiled by attention have too much love for

themselves. The beautiful coquettish woman can make a singularly disappointing lover. There may be more obvious reasons for loss of the sex urge — love for another man, disquiet over the husband's unfaithfulness or other misdemeanours, or homosexuality.

### Fear

A common cause of frigidity is fear of pregnancy and childbirth, instilled either by horrific stories or by personal experience. Other possibilities are a dread of sexually transmitted diseases and a guilty conscience over premarital sex experiences. Above all, however, is the fear of being hurt by coitus. This again can be inculcated by stories heard in adolescence or by actual initial personal experience. *All the causes of dyspareunia are causes of frigidity.*

### Contraception

Some women are inhibited by the practise of contraception, especially those with an underlying conscientious objection to it. Certain oral contraceptives, possibly because of their progestogen content, are said to decrease libido.

### Infertility

Long-standing infertility can result in a woman giving up all hope of conceiving; coitus can then become, for her, a frustrating, purposeless and disappointing affair; so any zest for it is lost.

Sterilisation of either the male or female partner can also cause the woman to lose desire, presumably because, subconsciously, this is always linked with the possible chance of conceiving—a strong impetus even when another child is not wanted. Conversely, if fear of pregnancy previously inhibited sexual desire, sterilisation improves it.

### Prolonged Separation from her Mate

This not infrequently causes female frigidity. In her husband's absence the wife deliberately stifles the instinct previously aroused and diverts her urge into other channels, one of these being her children. Having learned to live without him she may find it difficult to remove the inhibition on her husband's return.

## III Health, Physical Fatigue and other Interests

Any sort of ill health, acute or chronic, dampens sexual ardour, the reproductive function being sacrificed to conserve others. Notable exceptions to this rule are certain pyrexial illnesses, which sometimes increase libido.

Overtiredness is a common cause of apathy to coitus and is seen in women who attempt the dual task of running a home and undertaking a business or profession. Indeed, preoccupation of mind and body is one of the best ways to quieten sex drive, as is well known to those who have charge of organised groups of young people.

### Systemic Disease

Although cessation of ovarian function does not ordinarily cause frigidity, it can do so. Even more important, however, is adrenal failure, primary or secondary to pituitary hypofunction, with a consequent deficiency of androgens and corticosteroids in circulation. Thyroid dysfunction, diabetes mellitus and, indeed, any gross endocrine disorder can operate. Autonomic neuropathy in diabetes mellitus or demyelination in multiple sclerosis can affect the sexual response. Severe spinal cord injury can affect the ejaculatory response in men.

### Treatment

Elucidation of the cause and explanation of it to the woman and her partner is often enough to put matters right. Correction of long-established faulty outlooks can take time and patience but gives rewarding results. When the trouble is constitutional, however, little can be done except to see that the couple accept the situation philosophically. None of the alleged aphrodisiacs are of any value except possibly a small dose of alcohol which may temporarily remove inhibitions. Hormone therapy is singularly disappointing unless there is clear evidence of endocrine disease, when appropriate substitutional therapy is indicated. Methyltestosterone, 5 mg once or twice daily for a few weeks, used empirically, may be effective for female frigidity.

The psychosexual programme mentioned earlier has a role to play, for it temporarily removes the emphasis from the coital act itself, concentrating on evolution and other patterns of physical relationships.

## Failure to Achieve Orgasm

### Aetiology

*All the causes of sexual unresponsiveness:* Here again the emphasis is on constitutional, psychological and environmental factors. Failure to achieve orgasm is most often a deep-rooted inhibition; the woman is 'looking back over her shoulder' and is subconsciously afraid to 'let herself go'.

*Asynchronous orgasm:* There is considerable variation from time to time and person to person regarding the timing of orgasm, which often occurs earlier in the man than in the woman. The woman must learn to achieve orgasm and the man must learn whether it can be produced by vaginal or clitoral stimulation. The number of women who do not experience orgasm lessens with time but about 10 per cent of women may never achieve full sexual satisfaction or perhaps they do not achieve what they personally expect or believe they should. In some women there is satisfactory arousal initially but then there is a fall off in response with a decline in 'passion' over the years.

A basis of ritual circumcision in certain races is the belief that making the glans penis less sensitive prolongs coitus and makes the man a better lover. This is traditional rather than proved. Success as a lover depends on artistry rather than anatomy. Some authorities say that given the right man, every woman is capable of orgasm. Some women believe this too and have been known to resort to promiscuity in the hope of one day finding a partner who can satisfy them. This view would accept that many of the 10 per cent of women who never experience orgasm probably have not realised it is due to one or more of the listed aetiological, generally psychological factors. In other words, all women have the potential, but for one reason or another a climax is never achieved.

*Relaxed vaginal walls:* An overstretched vagina with lax pelvic muscles interferes with close sexual contact and sometimes makes it difficult for the woman to achieve orgasm.

### Treatment

This is similar to that described for sexual unresponsiveness, with the emphasis on explanation, education and attention to coital techniques. The temptation to blame the husband is to be resisted unless

there is clear evidence that he is at fault. Otherwise, it is not only unjustifiable, but can cause marital disharmony.

The couple should be advised to experiment with different coital techniques and postures. *Coitus a tergo* can induce vaginal orgasm when other approaches fail. There are also available proprietary 'sex aids'—gadgets which, fitted to the male phallus, can, according to their type, provide additional vaginal or clitoral stimulation.

Colpoperineorrhaphy in cases with relaxed vaginal walls can make coitus more satisfying.

When the woman never, or rarely, achieves orgasm despite full counselling, little can be done except to explain the situation. This is important lest the marriage suffer from the wife feeling that she is abnormal, and from the husband feeling that his wife is lacking in love for him. Failure to achieve orgasm in these cases is not usually harmful to the wife because her erotic status is such that she will not feel frustrated. Many women, even without reaching orgasm, still derive pleasure from intercourse; perhaps this is because it demonstrates a mutual deep affection.

## PREMATURE ORGASM

The occurrence of orgasm before penetration of the phallus, or very prematurely, is extremely rare in the woman. It can be simulated and is then used as a cloak to avoid coitus. It can also reflect male impotence. In genuine cases treatment is by advice to omit all love play before coitus.

## NYPHOMANIA

This is the opposite condition to frigidity and is one in which the woman has an incessant and over-powering desire for coitus. Nymphomania can become an obsession and even leads to soliciting in public.

### Aetiology

#### *Constitutional*

Just as some women have a minimal libido, others have an excess libido.

#### *Frustration and Orgasmal Incapacity*

Failure to achieve orgasm may be the force which drives a woman to seek coitus; indeed many nymphomaniacs are incapable of orgasm.

### *Psychoses and Neuroses*

Nymphomania can be evidence of a frank psychosis (generally in the manic phase of a manic depressive psychosis). Many subjects are women past the menopause and afflicted by a mild psychosis. These complain of an incessant urge which can never be satisfied, even temporarily. Coitus sometimes proves so frustrating that they avoid it despite the desire. Nymphomania can also be a manifestation of inner conflicts or of an unhappy home life going back to childhood. It may represent an urge to get the better of men and to satisfy self-esteem by many conquests and popularity.

### *Menopause*

An excessive sex urge is sometimes seen as a temporary reaction to the menopause; it probably arises from fear that attractiveness is passing and that only a short time remains in which to make the most of life.

### *Treatment*

The plight of the woman who complains of nymphomania is a serious one. She can offend against the law despite herself. The symptom is, however, difficult to treat unless the cause can be found and eradicated. She needs good contraceptive advice and regular checks for sexually transmitted diseases, as well as treatment for any underlying psychiatric condition. The most important general advice is that the patient should occupy both mind and body with other interests, and should avoid alcohol. Hormones are useless although progestogens are sometimes advised. A request by the patient for removal of the ovaries should be resisted, it is most unlikely to affect her symptoms.

## **COITAL DIFFICULTIES IN THE MALE**

### **Impotence and Male Frigidity**

As in the female, these are two separate conditions, commonly associated but not necessarily so. They constitute two of the most distressing marital difficulties, exasperating both parties and difficult to cure.

Male impotence is much more common than is generally supposed, male (and female) pride suppressing its mention. Its onset may be gradual or, in the case of a precipitating emotional upset, sudden. It may be constant or occasional and is seen in varying degrees.

Some men find themselves impotent with one woman and not with another. Most impotent men have good spermatogenesis and are potentially fertile.

### *Clinical Types*

- *Absence of sexual desire* and consequently of erection
- *Failure to obtain an erection of the phallus* despite libido. Men so affected may still have nocturnal erections and emissions and can masturbate.
- *Weak and fleeting erection* which subsides before penetration is complete
- *Normal erection and penetration but failure to emit semen* and to experience orgasm. This condition of 'partial impotence' is difficult to diagnose and the couple are often unaware of it themselves. It may only be revealed by finding no semen in a condom, or in the vagina, after what is regarded as complete coitus, and can be confused with retrograde ejaculation into the bladder. The latter is accompanied by orgasm.

### **Aetiology**

Male frigidity and impotence resemble female frigidity in that they are nearly always constitutional or psychogenic in origin - although the patient is reluctant to accept this. Often there is more than one factor operating and in nearly all cases a vicious circle is quickly established. Impotence results in loss of self-esteem and this in turn causes impotence. The more a man fails, the more likely he is to fail.

Slightly low levels of testosterone in the plasma are recorded by a few observers with constitutional, but not with psychogenic, impotence but these are of doubtful significance. Such a finding is more likely to be the result of sexual apathy and testicular disuse than to reflect a causal mechanism for the complaint. The administration of testosterone in such a case never restores potency so another postulate is an error in the metabolism of testosterone. There is little evidence to support this or the idea that a hormone deficiency plays any part in impotence which is not caused by a gross endocrine disorder (*see below*).

### *Physiological*

Impotence is physiological before puberty and with advancing years. Too frequent coitus at any age temporarily diminishes desire and capacity. Sexual capacity in the male is usually quite strong up to the age

of 50 years but thereafter slowly weakens. In old age the will sometimes remains stronger than the flesh but men of 80 years and more can be surprisingly potent.

#### *Constitutional*

Some men have minimal sex drive and some may even be completely unresponsive sexually. They have no interest in sex and marry for convenience or companionship. Such types often give a history of never having masturbated or experienced sex dreams; this in itself is strong evidence of abnormality and makes a cure unlikely. A man with minimal or no sex drive is not necessarily timid and undersized. On the contrary, he is often physically well built and handsome and sometimes is outstandingly athletic. This kind of man can be too self-interested and conceited to make a good lover.

#### *Early Impressions*

A history of a strict and religious upbringing, and of inculcation with ideas that sex is wicked, is common. The fond mother sometimes warns her only son against all women.

#### *Occupation*

Certain occupations such as those of a clerk or parson appear to be associated with impotence. The occupation may, however, merely reflect an unworldly or docile character and the upbringing of the individual. Preoccupation with work or hobby, overtiredness and business worries all reduce sex drive and can cause or exacerbate impotence.

#### *Lack of Affection for Wife*

Some men are incapable of deep affection for any woman; some have a mother fixation from childhood and cannot transfer their affection; others have an extramarital attachment.

#### *Homosexuality*

*See below.*

#### *Nervousness and Fear*

Overexcitement and anxiety lest coitus may fail explain, why impotence so often frustrates the first attempts at coitus. They are also the basis for failure after long separation of a couple.

Some men are over-considerate to their wives and are deterred from consummating marriage by fear lest they cause hurt or a pregnancy. They too have heard horrific tales of what parturition involves, or they may not want an interloper in the family. A subconscious desire to avoid the wife becoming pregnant is particularly important in the inhibition which prevents ejaculation despite normal penetration. Fear of transmitting reproductive tract infection and guilt over extramarital experiences are other possible causes of male impotence.

#### *Other Problems of Coitus and Conception*

Failure of the woman to respond to his advances can deter the husband and, if she takes amiss his early inadequacy, she may convert temporary into permanent impotence. Failure to realise the orgasmal capacity in the woman is also inhibitory to the man. Contraception by means of condom weakens the penile stimulus and can account for failure in a man who is not strongly sexed by reason of constitution or age. After a sterilisation operation impotence only occurs if the man expects it to.

#### *Organic Causes*

These account for only 5 per cent of cases of male frigidity and impotence and include the following:

- General ill health, debility, physical and mental exhaustion
- Complete testicular failure including that seen in the Klinefelter syndrome
- A defect in the output of hormones by the hypothalamic-pituitary system as a result of disease in that area can cause impotence by depressing adrenal and gonadal functions.
- Other frank endocrine disease of any kind and particularly diabetes mellitus
- Disease of the central nervous system, especially if it involves the anterior temporal lobes
- Depressive psychoses
- Generalised vascular disease
- *Castration:* Contrary to what is generally supposed, this does not always cause impotence and, when it does, probably acts psychologically as much as by deprivation of testosterone.
- Hypoplasia of the testes, cryptorchidism and orchitis do *not* usually affect either the hormone production by the interstitial cells or potency.

### *Drugs and Other Toxic Agents*

Drugs which sometimes destroy libido and encourage impotence include certain hypotensive agents and narcotics, depressants and tranquillizers; also oestrogens. Often it is impossible to say whether it is the drug, or the disease for which it is administered, which is operative.

Impotence is described in men handling pesticides and other chemical toxins. It is not uncommon in chronic alcoholics.

### **Treatment**

This must be preceded by diagnosis, and this means first a full clinical history, examination, and investigation to exclude an organic cause. There are devices in use to monitor nocturnal tumescence by plethysmography; if nocturnal erections occur an organic cause is excluded and a psychosexual history of both partners, interviewed separately, is essential. If an organic cause is found the treatment is clear. It is a mistake to overinvestigate constitutional and psychogenic impotence by way of hormone assays and the like. These are unprofitable and merely encourage the man to believe that his problem is an endocrine one and not a psychological or personality one.

The treatment of male impotence without an organic basis is as follows:

#### *General*

Little can be done to alter an inherent constitutional asexuality. In other cases the elucidation and explanation of psychogenic and environmental causes can give good results. This requires much time and patience, and the attitude must always be one of sympathetic encouragement. The man is helped if he knows that impotence is a common problem and that he is not unique.

The female partner has an important role to play in treatment. She must be made aware that, even if the fault is not hers, her full cooperation and active assistance are essential to a cure. Amongst other things she should be warned that no matter how exasperating the situation may become, recriminations can only do harm. Her man needs his self-confidence raised and if ever his manliness is questioned, or she makes him feel that he is failing her, the cure is inevitably postponed. By calculated word and deed, the wife may secure her husband's arousal.

Erotic films and literature, as well as group sex education and demonstration classes, are currently advocated by some 'counsellors'. Such therapy is unlikely to be of any benefit in cases of genuine frigidity and impotence in either sex.

#### *Specialist Psychiatric Treatment and Support*

This is recommended for those patients who do not improve with the general methods described above.

#### *Hormone Therapy*

Androgens by mouth, by injection or by implant are indicated only when there is clear evidence of hormone deficiency and are sometimes useful in ageing men. One also has to be aware that it may have an adverse effect by suppressing the hypothalamic-pituitary-gonadal axis. Otherwise they always fail except when they act psychologically. Impotence (and azoospermia) resulting from proven hypothalamic disease responds well to GnRH.

#### *Vasoactive Agents*

The intraurethral and intracavernous injection of a vasoactive agent is useful in men with neurological problems or with performance anxiety. Papaverine was used earlier. Apoprostadil, a prostaglandin-E preparation, has better results. The main side-effects, if not supervised properly, can lead to priapism.

Sildenafil (Viagra), a selective phosphodiesterase-5 inhibitor, enhances the effects of nitric oxide on nerve endings and endothelium. This causes relaxation of smooth muscle in the corpus cavernosum and blood vessels during sexual stimulation leading to cavernosal engorgement and penile erection. Minor side-effects include headache, nasal congestion, dizziness, visual disturbances and loose motions. The major complication is a precipitous fall in blood pressure and even myocardial infarction, seen especially in elderly men with coronary heart disease and those taking nitrates, as it potentiates their vasodilatory action. In fact, more than 30 deaths were reported within 4 months of its introduction. It should be used with caution in men with liver, kidney or bleeding disorders or with peptic ulcer disease. Sildenafil does not have any effect in the absence of sexual activity and does not cause priapism.



### Sex Aids

Plastic splints for the penis have been devised. The idea is to permit penetration; thereafter the stimulation by the vaginal wall may cause emission if not erection. Other mechanical sex aids are also advertised.

### Artificial Insemination

If the husband can produce semen by masturbation, intravaginal insemination of the wife is a valuable treatment in resistant cases. Great care must be taken in selecting the cases. It should only be done where a pregnancy is the highest priority and the couple are well adjusted to their non-coital sexual relationship. The occurrence of pregnancy removes the very important atmosphere of tension and urgency; the husband feels that he is no longer letting down his wife, and his self confidence is raised by the knowledge that he is responsible for the pregnancy. When the complaint no longer matters, its cure is spontaneous. Donor insemination (DI) is *not* advisable.

### Premature Ejaculation

In this condition erection may be either strong or weak; but it is always fleeting and emission takes place before, or immediately after, penetration. The wife therefore fails to experience orgasm. This problem may date from adolescence or only arise later in life after a period of normality.

Some regard premature ejaculation as evidence of oversex, an inability to control the urge; others classify it as a form of impotence.

### Aetiology

These include:

- All the causes of impotence
- Attempts at coitus before the erection is strong
- Overexcitement and inexperience in the early days or weeks of marriage
- Infrequent coitus.

### Treatment

- As for impotence
- If premature ejaculation is regarded as a manifestation of sexual *overexcitement*, instruct the couple to practise coitus frequently and to repeat it after very short intervals. Alternatively, the man may use a condom to reduce phallic stimulation.

- Pelvic floor exercises involving the deliberate contraction of the muscles used to interrupt micturition may allow the man to gain control over the emission.
- Monoamine oxidase inhibitors, e.g. clomipramine, delay ejaculation by interfering with conduction in the sympathetic nervous system. However, they should rarely be used for this purpose as serious side-effects may occur as a result of food or alcohol interactions and may be fatal.
- *The squeeze technique*: At the first suggestion of overexcitement, the penis is withdrawn and firm but gentle digital pressure is applied by the man or his partner to the glans penis until excess arousal subsides, and then coitus is recommenced.

## HOMOSEXUALITY

All individuals, male and female, have a potential for homosexual as well as heterosexual feelings and behaviour. Adolescent homosexual drive usually disappears with maturity or is readily resisted. Nevertheless, adult homosexuality is common in varying degrees and always has been throughout the history of the human race. Indeed, in some communities it is accepted without disapproval. In others the habit is regarded as antisocial and its practice is subject to legal controls. But law, opinion and discussion generally centre on male homosexuality; female homosexuality is less discussed, possibly because any adverse effect on society is minimal.

Although usually regarded as an acquired mental illness, homosexuality may be a genetic trait. It is sometimes classified as a type of psychological intersex but the sex chromosomes and hormone levels of affected individuals are always normal; and female homosexuals ovulate and menstruate regularly. Some combine homosexual with heterosexual activity; others do not. One could alternatively view sexual behaviour as a continuum, with pure homosexuality a polarised extreme and pure heterosexuality as the norm, and with various degrees of bisexuality in between.

Female homosexuality in an emotional form is common but in a physical form, with a recognised sexual purpose (*lesbianism*), is less prevalent. Nevertheless approximately 25 per cent of women are said to have had experience of it in some form at some time during life, but in only 3 per cent does it become a persistent and regular practice.

Female homosexual activity involves passionate kissing, general body contacts, mutual masturbation and genital contacts. Intravaginal stimulation is exceptional and the orgasm induced is usually clitoral. One partner may be consistently active or passive; sometimes roles are exchanged.

Lesbianism is generally harmless except for nervous reactions centred round feelings of guilt and degradation. It can, however, arouse intense jealousy if one partner marries; and it can lead to refractory heterosexual frigidity.

The practice exists mostly among unmarried girls, spinsters and widows, and is exceptional in married women. It is rife where girls are segregated in prisons and other corrective institutions. It is inherent in some girls but only acquired by others who come under the influence of a ringleader. The management of innocent puberty associations is therefore important lest they become permanent and pernicious.

An established lesbian who *wants* to remain such cannot be cured. The situation should therefore be accepted sympathetically and management directed to ensuring that her outlook and behaviour do not cause her to feel guilty or ashamed.

### TRANVESTISM AND TRANS-SEXUALITY

#### Definition and Clinical Features

Also sometimes regarded as forms of psychological intersex, and probably genetically (or possibly environmentally) determined in many cases, are the conditions of transvestism and trans-sexuality. These have been known throughout the history of the human race. The Roman emperor Nero is said to have been a transvestite. These differ from homosexuality in that the homosexual, whilst indulging in perverted sexual behaviour, does not wish to change his or her sex. *Transvestism* is a condition in which the individual has an urgent desire to dress in the clothes of the opposite sex. *Trans-sexuality* is a compelling urge to change sex, and cross-dressing is merely a part of this urge.

Cross-dressing in both transvestites and trans-sexuals usually begins in childhood and is a well-established practice by adolescence. By this time, too, other behavioural abnormalities may be evident. Some transvestites only cross-dress in private and may do so as a masturbating ritual; otherwise they can lead reasonably normal, although not very stable, married

lives. Neither transvestites nor trans-sexuals necessarily engage in active homosexual practices.

It is sometimes said that trans-sexuality is only seen in men. It is certainly more common in the male but it also occurs in regularly menstruating women.

Trans-sexuals often have a strong conviction that their sexual identity is misrepresented by their anatomy. They have an extreme revulsion for their genitalia. Women demand to have their uterus, ovaries and breasts removed; men demand removal of the phallus and the gonads. The innate psychological error behind trans-sexuality is also evidenced by an aggressive manner which shows even by abuse of the surgeon who refuses to undertake plastic surgery. Both transvestism and trans-sexuality may be evidence of frank psychoses but often the affected individual is not grossly mentally abnormal. The sex chromosomes and hormone levels of affected individuals are always normal, and so is the sex apparatus. Isolated findings of sex chromosome aberrations such as 45,XO/46,XY and 47,XXY are reported but are probably fortuitous and without cause-and-effect significance.

#### Treatment

Male trans-sexuals have sometimes been treated by removal of the phallus and testes, and by development of the breasts with oestrogens; creation of an artificial vagina to permit them to marry as women is also described. Female trans-sexuals have been subjected to bilateral mastectomy and excision of the internal genitalia including ovaries, supplemented by androgen therapy. These are the cases reported in the lay press as examples of a 'change in sex'.

Although this sort of plastic surgery has a few advocates amongst gynaecologists and psychiatrists, it is rarely justified. If it gave good results, any qualms about the ethics of removing normal functional genitalia merely on request might be quelled.

The prerequisites for consideration of surgery are to have lived for a defined period of time, usually 2 years, as a member of the *chosen* sex; psychiatric assessment of suitability; and, in the case of the male requesting to change to female (the more usual request), long-term oestrogen therapy before proceeding to the surgical stage of treatment.

In fact the results are generally unsatisfactory. The underlying psychological disturbance remains, and postoperative reactions include demands for more

surgery or for replacement of the excised sexual apparatus, and threats of legal action. Some men are reported to have died from cancer of the breast following the oestrogen therapy.

The treatment of tranvestism and trans-sexuality is therefore essentially psychiatric, but unless this is started in childhood, failure to cure is the rule. Indeed, whatever is done, medically or surgically, affected individuals usually continue as unhappy social misfits.

### PREMARITAL CHASTITY AND FAITHFULNESS IN MARRIAGE

The desirability of chastity before, and faithfulness after, marriage in both men and women are matters of morals and ethics rather than medicine. Medical practice nevertheless quickly reveals that the sex impulse is so strong that community codes of conduct are often broken if not flouted. In this respect it has to be recognised that morality is not absolute or static but relative to the general behaviour or opinion of any particular society at any given epoch. Throughout the centuries there have been alternating phases of sexual freedom and puritanism and, in the last three decades, there has been a sharp swing towards the former in many, although not all, countries and social groups.

The medical profession must view this trend with some concern because it is scientifically and statistically established that sexual licence and promiscuity affect not only the stability of family life and therefore the welfare of the community, they also affect the health of individuals. Promiscuity leads to a high incidence of sexually transmitted diseases including AIDS, of induced abortion with its attendant hazards, and of the social and welfare implications of single-parent families. Indirectly it leads to infertility and childlessness and directly to a risk of cancer of the cervix at an early age.

Being aware of these facts, doctors and especially gynaecologists have a duty to make them known; not to impose their own moral standards but to guide society in its thinking on sexual behaviour.

In many communities it has long been accepted that engaged couples may practise coitus, being faithful to each other before as after marriage. This is often a custom dating back to a time when it was economically important for a woman to prove her fertility before entering a legally recognised partnership. Even if such considerations are no longer important, it is clear that premarital intercourse as between a couple who have

every intention of marriage in the future is common. So, in many countries a high proportion of 'legitimate' babies are conceived before marriage.

However undesirable this practice may appear to some, such regular unions outside marriage rank differently from light-hearted *affaires* and open promiscuity. These last are much more likely to affect adversely the health and happiness of the individual and the security of subsequent marriage. In such circumstances, and without faith in the permanence of the relationship, coitus is not the anticipated glorious experience.

Irregular and haphazard sexual activity to the extent of intercourse is mostly influenced by considerations other than personal desire and gratification. Some acquiesce merely to show their affection for a man who makes selfish demands; some confuse sexual experience with love; some women partake to prove their emancipation. Above all, however, many women feel it imperative to conform to what they believe is fashion and to what is the 'done thing' by their contemporaries. In this respect, in recent years and in many countries, young and old of both sexes have been deliberately misled by literature, by the press, and by other mass media, into believing that sexual licence is the order of the day. Yet, except amongst certain groups and in large cities, this is not true.

If sex is advertised then, like any commodity, it finds ready buyers, even amongst those who do not really want it; and, simultaneously, public tolerance is lowered.

How can this trend be reversed or controlled to protect health? Marriage at an early age may take care of the passions of adolescence or steer them into the right paths but it is clearly established that the outcome is a very high divorce rate. So most authorities, sociologists and committees of enquiry reach the conclusion that the answer to sex, as to most other social problems, is education. The emphasis is therefore placed on the formal education at school, and at a relatively early age, of both boys and girls, in the physiology of sex and reproduction, and in sexual intercourse itself. In the hope of discouraging the latter except in proper circumstances, the education must, it is said, be extended to cover personal relationships and a sense of responsibility. But, in case this fails, the teaching must also include contraception and information about sexually transmitted diseases. These areas are now most important in the light of current teenage sexual behaviour.

It is remarkable that in these countries and societies where sexual behaviour still conforms to the pattern which has long proved best for organised society, sex education does not exist as a formal exercise; indeed, sex is still taboo. The control is by way of discipline imposed from childhood onwards and of fear of the consequences of departing from the accepted code.

Irrespective of one's personal views on sexual behaviour, one should never condemn or condone individual acts of which one has learnt in confidence. The medical attendant's duty is to accept the situation and, if consulted, to give such advice as one considers in the best interests of the physical and mental health of the patient. The following questions may arise.

### What to Tell the Partner in Marriage

In the past it was the rule that unless a child resulted, or unless it was inevitable that the information would leak from another source, neither man nor woman should reveal any premarital sex experience to the other partner. The basis for this was that no matter how understanding each may be, and how much one may dislike withholding secrets from the other, human nature is such that jealousy is inevitable — even though it be hidden for many years. At the present time, I believe that if it is discussed with the patient the final decision should be hers or his (as the case may be). I would err on the side of advising honesty at the outset, for deception is a shaky foundation for a marriage, but the decision must be theirs.

### The Unmarried Mother

The medical attendant is often the first to know when an unmarried girl is pregnant. Once the diagnosis is certain it is indicated to the patient gently, sympathetically and without actual or implied criticism. There is

less of a stigma attached to pregnancy outside marriage these days, although there is still the problem of how to manage it. In the case of a young girl I make it a general rule to advise the girl to confide in her mother. The normal mother will react by giving the girl every possible help whereas the normal father will often react sharply and critically; the mother can usually handle him best.

The first impulse of an unmarried woman may be to find someone who will induce abortion illegally and she must be warned against this, even frightened, lest she imperil her life, her future health and fertility. In countries where abortion on demand or request is legal, termination of the pregnancy under the best conditions will often need to be considered. This operation is only justified if it is clearly established to be in the best interests of the physical and mental health of the woman, and when it is reasonably certain that induction of abortion is less of a hazard to life and health than what is likely to be a completely normal pregnancy and labour. In the case of an unmarried girl it is often the parents who tend to override the wishes of the patient, and to disregard risks in order to protect the family's reputation.

It is necessary to present and discuss the options that are available to the patient (and to her mother or parents if appropriate). These are:

- to continue with the pregnancy
- to marry; this solution is only wise if the couple would have married anyway
- to have the baby adopted
- to have a legal abortion (if there are grounds and legal abortions are allowed).

The decision will ultimately depend on the social milieu of the patient which varies from country to country, the attitude of the mother and her economic status. In developed countries the first two options are more commonly exercised, in developing countries, the last two.

# CHAPTER 46

## Infertility and Assisted Reproductive Technology

Infertility	699	Assisted Reproductive Technology	721
Frequency	699	Results of Treating Infertility	728
A Concept of Fertility	700	Dangers of Investigating	
Causes of Infertility	700	and Treating Infertility	728
The Investigation of Infertility	703	Adoption	729
Treatment	715		

### INFERTILITY

Infertility is defined as the inability of a couple to achieve conception after one year of unprotected coitus. Sterility is an absolute state of inability to conceive. *Secondary infertility or sterility* are the same states developing after an initial phase of fertility. All these conditions can affect either the male or female partner of a marriage. Fecundability is the probability of achieving pregnancy within a single menstrual cycle, and fecundity is the probability of achieving a live birth within a single cycle. The fecundability of a normal couple has been estimated at 20 to 25 per cent. On the basis of this estimate, about 90 per cent of couples should conceive after 12 months of unprotected intercourse.

The desire of women for children is usually stronger than self-interest in beauty and figure, and may be stronger than the claims of a career. In men it is usually less intense. Childlessness may be a tragedy to the married woman, and can be a cause of marital upset as well as of personal unhappiness and ill health. The having of children cements a marriage and, when a breakdown of the partnership is threatened—as it is at some stage in many if not most marriages—the future welfare of their offspring may deter man and wife from separating.

Childlessness may result from recurrent abortion and stillbirth but the commonest cause is a failure to conceive; it is the latter problem which forms the subject of this chapter.

### FREQUENCY

Ten to fifteen per cent of marriages prove to be childless. The incidence of infertility does not appear to be increasing, but more couples are seeking advice because of increased publicity. Couples do not hesitate, as they did in former times, to reveal their problem.

Since the beginning of time human infertility has been a source of personal misery, and even of national crises. It was once, and still is in some communities, regarded as a disgrace, as a mark of Divine displeasure, as grounds for divorce and

even for compulsory suicide (on the part of the woman only!). The Egyptians, Greeks and earlier civilisations all had empirical treatments — love potions, amulets, prayers, sacrifices and the like. Although the female partner was generally blamed, the Greeks at least were aware of male infertility.

### A CONCEPT OF FERTILITY

Fertility is a relative rather than an absolute state, and comparatively few individuals are fully sterile or fully fertile. The majority fall somewhere in between these two extremes, and the fertility of a marriage is a sum of the fertilities of the two partners. Low fertility in one can to some extent be balanced by high fertility in the other, whereas low fertility in both partners may result in infertility. This explains why some couples fail to reproduce yet, when they separate and each takes a new mate, they both proceed to have children. Incompatibility in the sense in which it was formerly envisaged has not been demonstrated so far, although the parts played by various combinations of blood group and possible immunological reactions of the woman to a particular semen have been, and are being, studied intensively.

Fertility also varies from time to time in the same individual. In the male these are not obvious except during childhood and, less absolutely, in old age, but in the female, physiological infertility is seen:

- Before puberty
- After puberty and before maturation. Although menstruation may be occurring regularly, fertility is usually low until the age of 16–17 years. The explanation of this is unknown although it is sometimes assumed that it is because a higher percentage of menstrual cycles are anovular in the earlier years.
- During pregnancy, when ovulation is suppressed
- During lactation
- Before the menopause. After the age of 34 years, fertility falls; there is a gradual decline in conception rates with age. Conception rates also depend on many factors including, in many countries, the tendency for smaller families.
- After the menopause

### CAUSES OF INFERTILITY

There are still some cases of unexplained infertility, despite the increased sophistication of tests now

available. The proportion of cases of unexplained infertility seen in any clinic depends on the facilities available, varying from 6 to 60 per cent, but is usually seen in about 10–20 per cent. There are some factors which have still not been identified. In many cases, however, several adverse factors are operative and if these are distributed between the partners it may be impossible, even if it were desirable, to apportion the 'blame'. The diversity and multiplicity of possible aetiological factors emphasises the need for meticulous investigation to reveal them.

In any series of infertile marriages, the main aetiological factor is found in the female in about 40 per cent of cases; about 35 per cent of the husbands concerned have some degree of infertility. In 10–20 per cent of cases, a combination of factors operates and the rest have unexplained infertility.

### Failure to Produce Spermatozoa in Sufficient Numbers and With the Capacity to Fertilize

In most cases of azoospermia and oligospermia the underlying cause is not clear, although it is now accepted that motility and abnormal forms are at least as important as the number of spermatozoa. Established and postulated causes include the following:

- Incomplete development of the testes. The frequency of sex chromosomal aberrations among men with aplastic testes and azoospermia is probably high.
- Late descent, or non-descent, of the testes which may or may not be the result of the former cause. In either case, the spermatogenetic function of the testis depends on its extra-abdominal site, probably because of the ill-effect of heat on the seminiferous tubules. The tissue temperature of the scrotal testis is 2°C lower than that of the rest of the body.
- Previous orchitis due to mumps or other severe infectious fevers (including influenza), or chlamydial infection occurring after the age of 14 years. Orchitis complicates 25–50 per cent of cases of adult mumps.
- Damage to the testes resulting from operation, accident or exposure to X-rays. The injury may be to its blood supply rather than to the gonad itself.
- Exposure of the testes to heat impairs spermatogenesis, at least temporarily; frequent hot baths or the wearing of non-porous nylon underwear and suspensory garments may have this effect. Varicocele is not uncommonly found in infertile men; if its association is causal it may be because it raises the

scrotal temperature or leads to anoxia of the testicular tissues. Workers in foundries or welders may similarly be exposed to high temperature.

- Diseases of the testes such as tumours, tuberculosis and syphilis
- Depression of testicular activity by disease of other endocrine glands (especially the hypothalamic-pituitary system, e.g. hypogonadism as in the Lawrence-Moon-Biedl or Frolich syndrome, thyrotoxicosis, diabetes mellitus), by general ill health and by drugs and poisons. Steroids in high doses, antiandrogens e.g. cyproterone, spironolactone, cimetidine and cannabis depress the hypothalamic-pituitary-testicular axis. Methotrexate, colchicine, nitrofurantoin, sulfasalazine, cocaine and alcohol act directly on the testis. Nifedipine, allopurinol and nicotine impair the fertilising capacity of the sperm, while sperm motility is impaired by lignocaine, procaine, propranolol, quinine, chlorpromazine, minocycline and tetracycline.
- **Age:** Male fertility tends to diminish after the age of 40 years although spermatogenesis usually continues to some extent until old age. Octogenarian fathers are by no means rare.
- **Spermagglutinins and antibodies:** In some infertile men, or following operations for reversal of vasectomy, spermagglutinins are demonstrable in circulation, which may damage seminiferous tubules as well as cause spermatozoa to agglutinate after ejaculation. Other local and circulatory antibodies to testes as well as to spermatozoa are described in the male.

### Bilateral Obstruction of the Epididymis, the Vas or the Ejaculatory Ducts

These may be caused by the following:

- Accident or operation, especially herniorrhaphy
- Infections, of which gonorrhoea and tuberculosis are the most important; the lesion is usually an epididymitis
- Congenital absence or gross hypoplasia of the vas
- Congenital or developmental obstruction of the epididymis which is usually associated with congenital cystic disease of the lungs to form a definite syndrome.

### Failure to Deposit Spermatozoa in the Vagina

- Impotence (including the type in which erection and penetration take place but there is no emission)

- Premature ejaculation
- Abnormalities of the penis such as hypospadias and phimosis
- Retrograde ejaculation into the bladder. This happens after prostatectomy and certain nerve resection operations. It can also occur in apparently normal men.
- Drugs which affect ejaculation include  $\alpha$ -blockers, ganglion blockers, the tricyclic antidepressants, MAO inhibitors, phenothiazines,  $\beta$ -blockers and thiazides.

### Abnormal Semen Quality

- An unusually high or small volume of ejaculation
- Other physicochemical anomalies which may or may not be significant are low fructose or high prostaglandin content, and undue viscosity
- **Oligozoospermia:** Less than 20 million sperm/ml
- **Asthenozoospermia:** Less than 50 per cent sperm with forward progression or less than 25 per cent with rapid progression
- **Teratozoospermia:** Less than 30 per cent morphologically normal forms
- **Asthenoterato-oligozoospermia:** Combinations of the above
- **Azoospermia:** Absence of sperm in the seminal fluid; aspermia is the absence of ejaculate.

### Female

#### Ovarian Factors

In women menstruating regularly this is a cause operating in about 15 per cent of cases of infertility. Regular anovulation in menstruating women can be a feature of hypothalamic anovulation, hyperprolactinaemia (due to drugs, pituitary adenoma or primary hypothyroidism), polycystic ovaries (Fig 46.1), subclinical adrenal failure and diabetes mellitus, luteinised unruptured follicles and luteal phase deficiency. However it is not clear whether the last two can cause infertility.

Generally, failure to ovulate is associated with amenorrhoea or oligomenorrhoea and has the same causes (*see* Chapter 37). These include sex chromosome anomalies. Premature ovarian failure due to premature menopause or resistant ovary syndrome is also seen. Anovulation is also a feature of luteal phase deficiency and the luteinised unruptured follicle.

Luteal phase defect can be short or long, but is more often the latter. There is decreased hormone production



Fig. 46.1: Polycystic ovary on a TVS scan

by the corpus luteum as well as decreased levels of follicle stimulating hormone (FSH) and luteinising hormone (LH). Some women have hyperprolactinaemia and hypothyroidism; others have unexplained infertility with normal cycles; or are habitual aborters.

#### Peritoneal Factors

Pelvic adhesions may operate by preventing the tube performing its 'octopus' function at the time of ovulation or by creating a mechanical barrier between the ovary and the tubal ostium. They result from pelvic peritonitis of any kind but especially that seen in association with appendicitis, and postabortal or puerperal infections. Endometriosis is seen in at least 15 per cent of women investigated for infertility, if all grades are considered.

#### Tubal Factors

Peritoneal and tubal factors may account for up to 35 per cent of all cases of infertility. Partial or complete bilateral tubal obstruction results from previous salpingitis. Most commonly this is postabortal, puerperal, gonococcal, chlamydial or tuberculous in nature.

#### Uterine Factors

- Uterine absence, atrophy or hypoplasia of a degree sufficient to bar the ascent of spermatozoa causes amenorrhoea as well as infertility.
- Tuberculous endometritis

- Intrauterine adhesions (Asherman's syndrome) due to previous overzealous curettage or previous surgery on the uterus
- Submucous polyp
- Uterine leiomyomas. The mechanisms that apply here are discussed in Chapter 30.

#### Cervical Factors

- Impenetrable cervical mucus or poorly penetrable mucus due to the presence of local sperm antibodies or due to low pH of the mucus at midcycle are a definite entity, the aetiology of which at present remains obscure.
- Loss of mucus due to amputation of the cervix, cone biopsies or overenthusiastic cervical diathermy.
- Faulty direction of the cervix such as is found in retroversion or severe prolapse.
- *Cervical stenosis*: Some of the women have a tight internal os which may be found during procedures and needs dilatation.

#### Vaginal Factors

- *Purulent discharge*: This is a doubtful cause of infertility because spermatozoa can thrive in pus under *in vitro* conditions. Moreover, clinical observations go to show that many women with chronic cervicitis and *Trichomonas* vaginitis conceive repeatedly without difficulty; some contract gonorrhoea and pregnancy simultaneously!
- Vaginal tumours, septa and membranes preventing the spermatozoa reaching the cervix.

#### Coital Errors

##### *Apareunia and Dyspareunia*

Of those women seeking advice on account of infertility, 1-2 per cent are found not to have consummated their marriage. Many of these do not realize the fact; nor do their husbands.

##### *Frequency and Timing of Coitus*

Coitus has to take place every 48 hours during the fertile period to offer the optimum chance of conception. Too frequent coitus rarely, if ever, accounts for infertility.

Infrequency of coitus and attempts to limit it to the day of ovulation are much more important causes for failure to conceive.



### *Lubricants*

When coitus is difficult due to a dry vagina, many couples resort to using lubricants of one type or another without realising that these have a contraceptive action. Proprietary jellies are often acidic and therefore spermicidal, while greases such as soft paraffin and lanolin bring spermatozoa to a standstill.

### **Other Factors**

Among the many factors popularly believed or alleged to lower fertility, the following deserve mention.

#### *Orgasm*

It is unnecessary for the woman to experience orgasm in order to conceive; if it were otherwise pregnancy would never result from rape.

#### *Effluvium Seminis*

Immediately after coitus most of the semen escapes from the vagina and patients often think this is the reason for infertility. *Effluvium seminis* is normal and is never a cause for infertility; there is always enough semen left behind for fertilisation. Only the spermatozoa which enter the cervical mucus are capable of fertilising an ovum, so the loss of the remainder is irrelevant. Spermatozoa only account for about 10 per cent of the seminal fluid volume.

#### *Anxiety and Apprehension*

It is commonly believed that a nervous temperament, particularly extreme anxiety to conceive, lowers fertility. It is therefore often stated that when a couple adopt a baby they are likely to have one of their own soon afterwards: this, however, has not been confirmed by statistics.

#### *Familial Disposition; Genetic and Constitutional Factors*

Some families appear to have a high, and others a low, conception rate but the explanation is generally not clear. The infertility which goes with obesity, heavy build and masculine traits is merely one other manifestation of an underlying constitutional abnormality; weight (although it can affect the hypothalamic-pituitary-ovarian axis) and shape are not the direct causes of childlessness. Athletic prowess and pursuits are now recognised to lower fertility by virtue of anovulation and amenorrhoea.

### *Occupation and Environment*

Fertility *appears* to be higher among rural than among urban dwellers, and amongst those who live by manual labour than amongst those whose work depends mostly on mental activity. Many factors may be responsible for this including differences in the ages at which marriage takes place and in the practice of contraception in the various social classes. Statistics suggest that fertility does *not* vary *directly* with social class. However, various conditions do have a predilection for certain classes, for example, endometriosis in higher socioeconomic classes and pelvic inflammatory disease in lower socioeconomic classes; these relationships are reflected in statistics. There is also a trend in professional couples to defer pregnancy until careers are established. Attempts to conceive during the years of natural decline in fertility, and a possible increase in gynaecological pathology (endometriosis for example) may distort the statistical analysis in future.

#### *Diet*

The diet should not be so deficient or unbalanced as to interfere with ovarian function, as in cases of anorexia nervosa. There is increasing evidence of the role of micronutrients in fertility. Deficiency of zinc and folate are implicated in decreased spermatogenesis possibly through defective DNA and RNA synthesis. Deficiency of dietary antioxidant micronutrients, e.g. beta-carotene, lycopene, retinol and  $\alpha$ -tocopherol may decrease genital tract secretions in men, leading to infertility especially through immunological mechanisms.

#### *Contraception*

Hormonal contraceptives may sometimes result in a delay in the return of ovulation or in persisting anovulation, while intrauterine devices can cause salpingitis and tubal damage.

Postponement of childbearing by any means does, however, mean that time is passing, so even when contraception is discontinued the age factor may be operating.

## **THE INVESTIGATION OF INFERTILITY**

### **When Should Infertility be Investigated**

A highly fertile couple practising coitus regularly take an average of 6-7 months to achieve a pregnancy, and

four out of five women conceive within one year of commencing regular coitus without contraception. Failure to conceive during 12-18 months despite adequate opportunity is therefore always acceptable as justifying full investigation. A strong case can be made for investigating infertility of only one year's duration — especially if the woman is aged over 30 years or the man is aged over 40 years. A clinical examination of both partners, and possibly semen analysis is indicated as soon as any couple becomes worried.

An important preliminary to the investigation of infertility is to make certain that the woman is not suffering from a disability which might contraindicate pregnancy or make it undesirable. These conditions are present in 1 per cent of women patients seeking advice and it is poor practice to encourage a pregnancy which has to be terminated.

### Clinical Assessment of Both Partners

#### History

The man and wife ideally should be questioned separately and then together, partly to have their evidence corroborated but mainly because either may have something to reveal confidentially. The special points on which information is required are as follows:

- Ages, occupations, previous marriages
- Duration of marriage and the period of time during which contraception has been practised
- Are the partners separated for significant periods of time?
- Previous illnesses and operations. Has the woman had appendicitis, peritonitis, tuberculosis in any site, or any operation on or near the genital tract? Has the man had orchitis, renal disease, bronchiectasis or any operation on or near the genital tract? Has either suffered from gonorrhoea or *Chlamydia* infection or symptoms suggesting them? Severe head injury, meningitis and encephalitis can affect the function of the hypothalamic-pituitary axis.
- The family medical history of each, looking especially for tuberculosis on the woman's side
- Has the woman ever been pregnant by her husband or by another man?
- Has the husband been responsible for pregnancy in another woman?
- Is coitus normal and painless, how frequently is it practised and at what time in the cycle? Some couples

have a wrong idea about the fertile period. More specific questions may be asked about their relationship and details regarding coitus, including erection, ejaculation and penetration.

- Details of menstrual function including factors which favour an ovulatory cycle
- Has the woman any other symptoms referred to the genital tract?
- Drugs, e.g. mefenamic acid taken for mittelschmerz pain, may interfere with ovulation. Drugs used for treating hypertension (e.g. guanethidine) may cause impotence and salazopyrine (for ulcerative colitis), cytotoxic drugs, immunosuppressives and nitrofurantoin reduce the sperm count.
- Alcohol intake may reduce the potency and frequency of coitus.

#### Examination

This should cover all systems with particular attention to the reproductive systems where abnormalities of the penis; cryptorchidism; the size and consistency of the testes and epididymis; the presence of the vasa; a varicocele and any prostatic abnormality in the man; assessment of the vagina; the size, position and mobility of the uterus; and any enlargement or fixation of the adnexa in the woman should be looked for.

In all women with infertility, special attention must be paid to the body habitus, weight, thyroid, breast and note made of the presence of galactorrhoea, acne or hirsutism.

### Assessment of Male Fertility

#### Clinical

Paternity is probably the best proof of male fertility, yet it can be misleading. The wide variation in results of semen analysis in fertile and infertile men at different times makes reassessment essential if a couple requests advice regarding their ability to conceive. Responsibility for two or more pregnancies, however, usually means good fertility, provided the effects of advancing years and of intercurrent disease can be excluded. There are however, very few cases of infertile partnerships in which investigation of the male partner is not essential. Careful inquiry into past illnesses and examination of the genitalia usually reveal some abnormal finding in approximately 20-30 per cent of infertile men. In others it is disclosed only by semen analysis. Physical

examination of the male is mandatory if semen analysis is abnormal.

### *Semen Analysis*

The demonstration of spermatozoa in material removed from the vagina or cervix after coitus is *inadequate* for the purpose of assessing male fertility. Whatever be the findings on a postcoital test, full semen analysis is also essential.

For this purpose, semen collected in a condom during coitus is unsatisfactory because the rubber and its preservative powder are spermicidal. The specimen is best collected after 3 days of abstinence, masturbating directly into a dry and clean wide-mouthed glass container. It is kept as close as possible to body temperature (by carrying it in a hip pocket), and its examination carried out as soon as possible after it has liquefied (this takes half an hour), preferably within 1 hour, as motility declines progressively with time. Collection under home conditions is generally preferred by the 'patient' but for optimal results it is best carried out near the laboratory. Semen analysis should be carried out on *at least two different occasions if the first test suggests impaired fertility*.

Of all the characteristics of semen which can be studied, the essential ones are volume of fluid; number, motility and morphology of spermatozoa.

There is no such thing as a 'normal' semen because of the wide fluctuations present in any one individual, but according to the WHO criteria, the volume should be 2-6 ml; liquefaction should be complete in 30 minutes; the sperm count should be 20 million/ml or more; 60 per cent should have forward progressive motility or 25 per cent or more should show rapid progression within 60 minutes of ejaculation and 70 per cent or more must be morphologically normal. Fewer than 1 million white blood cells per ml should be present.

Computer assisted semen analysis (CASA) was introduced to remove inconsistencies in sperm counts with traditional methods. However, errors still occur especially with low counts when other cells can be miscounted as sperm. The CASA systems can also provide information on sperm velocity which is suggestive.

Immature forms of spermatozoa are ranked as morphologically abnormal. Any one specimen is assessed by considering these features *in relation to each other*. For example, a low percentage of morphological abnormalities may compensate for a poor sperm count

while a small volume detracts from a high sperm density. A very high volume with resulting dilution can be a disadvantage.

Caution is necessary in interpreting the significance of motility of spermatozoa because this varies so much with the conditions of collection and storage of the specimen. When the number and morphology of spermatozoa are good, the finding of poor motility should be taken seriously for it may be due to anti-sperm antibodies. True absence of motility (*necrospemia*) in a fresh and *otherwise normal* specimen is an extremely rare finding. Usually 70-80 per cent of spermatozoa are motile when the specimen is collected.

The presence of pus cells indicates an inflammatory lesion, usually in the prostate, but is not necessarily significant so far as fertility is concerned. Semen culture should be done. Urethral swabs are required for chlamydial culture. Most men with pyospermia prove fertile without treatment; nevertheless pyospermia in an infertile man is best treated.

Fructose is secreted by the seminal vesicles and is essential to the metabolism of spermatozoa as it provides energy for their movements. At the time of ejaculation, semen contains 200-300 mg/dl fructose but this falls to 100 mg/dl in 4-8 hours. When azoospermia is the result of an obstructive lesion, absence of both fructose and spermatozoa indicates that the block is at or below the level of the ejaculatory ducts. Infection of the seminal vesicles also decreases the ejaculate volume resulting in low fructose levels. Prostate infection can lead to obstructive oligo- or azoospermia and a lowered zinc concentration.

When semen is not emitted and retrograde ejaculation is suspected, the urine collected immediately after orgasm should be examined for spermatozoa.

Low male fertility, as found on semen analysis, should be *understated* to the couple concerned because it is impossible to interpret the results except in very general terms. An analysis from the infertility clinic in Liverpool showed that 33 per cent of women complaining of primary infertility of not less than 2 years' duration, and whose husbands' sperm counts were less than 10 million per ml in average volume, subsequently conceived, without the male being treated or taking into consideration any female infertility factors which may also be present. However, the success rate as judged by conception in such cases is usually only about 10 per cent.

**Trial Wash:** It is now found that all semen samples should have sperm wash done to evaluate the motile sperm counts and this is called as trial wash.

- Performed during semen analysis
- Evaluation of semen for various assisted conception procedures
- Helps to select suitable sperm wash methods and helps to plan treatment

Number of motile spermatozoa inseminated (NMSI) and morphology on the success of intrauterine insemination has been studied. When the NMSI was more than 5 million postwash with a normal morphology of more than 30 per cent the pregnancy rate per cycle was 18.42 per cent, whereas if NMSI was less than 5 million postwash and morphology of less than 30 per cent the pregnancy rates per cycle was 5.43 per cent. Hence, postwash sample with more than 5 million sperm count per ml of the total number of motile sperm inseminated (NMSI) lead to better pregnancy rates. However, in those who yield less NMSI, if few cycles intrauterine insemination (IUI) fails should be considered for Assisted Reproductive Techniques (ART).

### Sperm Function Tests

The lack of correlation between the various aspects of the semen analysis and fertility outcomes led to the development of tests for sperm function. However, these are also of limited utility because each of them tests only one aspect of sperm function. With the development of intracytoplasmic sperm injection (ICSI) (*see below*) their importance in clinical practice is doubtful.

Sperm function tests vary in their ability to detect defects in the complex processes leading to fertilisation, and are of limited use from a practical point of view (The ESHRE Capri Workshop 1996). Unless there is azoospermia, the predictive value of subnormal semen variables is limited. No functional test has yet been established that can unequivocally predict the fertilising capacity of spermatozoa.

### Sperm Penetration Assay

Healthy sperm penetrate most, specially processed hamster ova from which the zona has been removed, and produce a significant degree of polyspermy per egg. The unhealthy sperm penetrate a lower number of ova and produce less polyspermy. A minimum of 10-30 per cent ova are normally penetrated. The results of the test

vary from time to time in the same individual and do not correlate with eventual fertility. However, this helps in early identification of patients who may be better suited for ICSI or donor insemination, especially in cases of unexplained infertility.

### In vitro Sperm Penetration Tests

If the postcoital test (*see below*) is poor, an alternative test is to place a drop of sperm on a glass slide alongside commercially available bovine mucus and to microscopically study its invasion by the spermatozoa (sperm penetration test). A modification of this type of test is to use an *in vitro* cross-over sperm-cervical mucus contact test (SCMCT), that is, to use mid-cycle mucus and semen of the couple under question and compare it with donor sperm and donor mucus (Kremer test). However, these are of little practical value as couples with poor postcoital tests or unexplained infertility will be treated with intrauterine insemination (IUI).

### Other Tests

The CASA systems can provide information on the number of spermatozoa in a hyperactivated motility state which is suggestive of *capacitation* and on the *hypo-osmotic swelling* test which assesses the tail membrane function. Non-motile sperm with a positive hypo-osmotic test are reported to do better with ICSI than non-motile and negative hypo-osmotic test sperm.

The *hemizona* assay tests the ability of the sperm to pass through the zona of the human egg. This test is no longer done following the development of ICSI.

### Sperm Antibodies

Semen is known to be highly antigenic and sperm antibodies are a known cause of infertility. Agglutination is the sticking together of sperm in variable patterns, e.g. head-to-head, tail-to-tail, mixed agglutination. It is caused by anti-sperm antibodies which are usually IgA or IgG. Further tests like the immunobead or mixed antiglobulin reaction (MAR) test can be done for the detection of these antibodies in semen. The immunobead test can also be used to detect antibodies in serum or cervical mucus. With this test, less than 20 per cent of sperms should be covered with adherent particles or beads. These tests are indicated when the semen analysis shows oligo-or azoospermia; spontaneous sperm agglutination or low motility; an abnormal postcoital test;

in the presence of infection; if there is failure of conception after vasectomy and in cases of unexplained infertility.

### Hormonal Assessment

Up to 10 per cent of sub-fertile males have endocrine abnormalities. Routine testing for endocrine dysfunction is not indicated; but should be carried out in those men found to have oligospermia or azoo-spermia. Follicle stimulating hormone, LH, prolactin and testosterone levels are helpful in this assessment.

A raised FSH level reflects failure of spermatogenesis. Low levels of FSH and LH are diagnostic of hypogonadotropic hypogonadism. Normal FSH levels with normal testes but azoospermia suggest obstruction. Raised LH levels with low testosterone levels indicate Leydig cell dysfunction. A low testosterone level warrants replacement therapy.

Prolactin levels are not done routinely. Rarely, in cases of impotence or decreased libido, hyperprolactinaemia is seen without evidence of hypogonadism.

Thyroid dysfunction is so rarely a factor in men that it is not necessary to assess thyroid stimulating hormone (TSH) levels unless clinical features indicate it.

### Testicular Biopsy

Testicular biopsy is generally not recommended as the disruption of the blood-testes barrier can lead to the development of autoimmunity against spermatozoa. It is indicated in cases of azoospermia with normal FSH and inconclusive seminal markers to distinguish between a failure in spermatogenesis and an obstruction to the outflow of spermatozoa. It also reveals whether the tubules are basically normal but unstimulated or whether they are incapable of function. Examination of the material obtained requires a histologist with special experience.

### Varicocele Assessment and Significance

A varicocele is a collection of dilated veins in the spermatic cord and is a common physical anomaly. Varicoceles are found in 11.7 per cent of men with normal semen and 25.4 per cent of men with abnormal semen (WHO 1992). The mechanism by which varicoceles might impair fertility and spermatogenesis is not clear. Varicoceles may be associated with decreased ipsilateral testicular volume, elevated scrotal temperature and pain,

as well as impaired semen quality (WHO 1992). Review of several randomised controlled trials showed that varicocele repair did not improve pregnancy rates. Some studies on varicocele are contrary. It was found that following varicocele surgery a rise of sperm count was seen in 31 per cent when it was < 5 million/ml prior to surgery. Hence, if there are gross varicoceles in an individual who has fluctuating levels of sperm count and motility varicocele surgery may be worth a try. If there is an improvement in the count and motility following varicocele surgery then the couple may benefit by IUI in some cases rather than having the only option *in vitro* fertilisation (IVF) or Intracytoplasmic sperm injection (ICSI).

### Other Tests

Vasography is used in cases of proximal vas deferens obstruction before microsurgical repair. Transrectal ultrasonography is combined with seminal vesiculography to demonstrate ejaculatory duct obstruction. Chromosomal analysis is indicated in men with eunuchoid features and oligozoospermia, who may have the 47,XXY complement of Klinefelter's syndrome (seen in 2 per cent of men with oligo-zoospermia). A high prevalence of Y chromosome submicroscopic deletions is also reported in oligo-zoospermic men.

### Assessment of Female Infertility

#### Importance of Body Mass Index (BMI) and Obesity

##### Effect of fat on hormones:

- Effects not only gonadotropin secretion but also 17- $\beta$  oestradiol metabolism.
- It metabolises to weaker oestrogen-oestriol.
- There is also conversion of androstenedione to oestrone in peripheral adipose tissue.

##### BMI (Body mass index):

Obesity > 30 kg/m<sup>2</sup>

Average = 25 kg/m<sup>2</sup>

Requires

treatment > 28 kg/m<sup>2</sup>.

##### Significance of Basal Hormonal Evaluation

An elevated basal day-three FSH is correlated with diminished ovarian reserve in women aged over 35 years and is associated with poor pregnancy rates after treatment of ovulation induction.

Basal levels less than 10 mIU/ml is considered as normal for a normal ovarian reserve. It has been reported that pregnancy rates decline significantly as day-three FSH rises above 15 mIU/ml. Very few pregnancies were reported when FSH exceeded 25 mIU/ml. Basal LH values of more than 10 IU/L is not a good value as this high LH will deteriorate the quality of oocytes.

#### *Estimation of the Time and Frequency of Ovulation*

After the basic work-up has been done, it may be wise, even in regularly menstruating women, to look for presumptive evidence of ovulation or luteinisation. The methods for assessment are described in Chapter 5 but the one which has been overemphasised in recent years is the daily temperature record. This method has the advantage of indicating the approximate time of ovulation, and therefore the time when coitus is most likely to be fruitful. Its disadvantages are that it is a daily reminder of childlessness; it tends to make couples time their acts of intercourse with a mathematical precision and changes married love into a coldly calculated duty. When temperature recording is considered necessary, it should never be continued for longer than 3–4 months, by which time it should be possible to assess the ovulation habit. Ovulation pain (Mittelschmerz) is also an indication of ovulation.

### Ultrasonography

#### *Baseline Transvaginal Ultrasound Scan*

This is done to identify uterine abnormalities such as endometrial polyps, submucosal fibroids, or congenital defects. The findings of a thin endometrium (<4 mm) and quiescent ovaries on the baseline scan reflect the hypo-oestrogenic state of the early follicular phase, which provide the optimal conditions with which to commence treatment. Conversely, a thick endometrium represents endogenous hormonal stimulation above normal basal levels and indicates that the patient should not initiate the cycle.

Unilocular, clear cysts may represent functional cysts or unruptured luteinised cysts. Complex ovarian cysts detected at baseline usually reflect old haemorrhagic corpus luteae and are commonly seen if the patient has been treated with gonadotropins in the previous cycle. Nevertheless, the differential diagnoses, including endometrioma (Fig. 46.2), benign ovarian tumour, or malignancy, must be considered. The management of

ovarian cysts present at baseline is controversial. More importantly, these ovarian cysts tend to resolve spontaneously within 1 to 2 months. Low-dose oral contraceptive has a lower efficacy than older, high-dose oral contraceptive in preventing the formation of new cysts. Since oral contraceptives do not affect the speed of resolution of old cysts, they are not necessary in this scenario. Evidence of ovarian endometriomas can be made out.

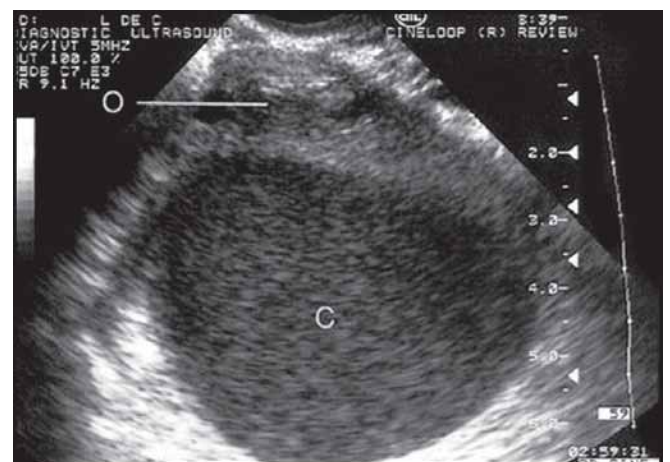
Ultrasound is commonly used to track follicle development and is better observed with transvaginal than with abdominal ultrasound. The follicle size at ovulation is very variable but usually the dominant follicle is 17 mm in diameter. Follicles are larger in stimulated cycles, being 18–20 mm in diameter and larger with clomiphene than with human menopausal gonadotrophin (hMG).

The endometrium increases in thickness from a thin broken line in the early follicular phase to double its size; in the peri-ovulatory period it appears sonographically as a triple layer in the long axis of the uterus and is usually about 10–12 mm in diameter. The luteal endometrium loses both the hyperechogenicity and the triple-layered appearance.

The diagnosis of luteinised unruptured follicle is made on ultrasound when the follicle does not rupture, although serum progesterone rises to postovulatory levels.

#### *Hormone Assays*

Serum progesterone level measured during the mid-luteal phase is the most reliable method of confirming



**Fig. 46.2:** Chocolate cyst

ovulation, the minimum level being 6.5 ng/ml and preferably over 10 ng/ml. A single low progesterone level is insufficient to judge the adequacy of the luteal phase.

Detection of the preovulatory LH surge has also been used to predict ovulation. Urinary LH kits and salivary progesterone have been used as discussed in Chapter 5. However, hormone tests are expensive and not universally available.

Other hormones which may need to be assessed are free T3, T4 and TSH, serum FSH and LH in the immediate postmenstrual phase, and serum prolactin.

### Endometrial Biopsy

There is no consensus of opinion about the diagnosis or effective treatment of luteal-phase defect, and its role as a cause of infertility has been questioned. The benefit of treatment for luteal-phase defect on pregnancy rates has not been established. Women should not be offered an endometrial biopsy to evaluate the luteal phase as part of the investigation of fertility problems because there is no evidence that medical treatment of luteal-phase defect improves pregnancy rates. However, in a developing country when tuberculosis is suspected when a thin endometrium is seen there is a role for endometrial curettage in selected cases.

Endometrial aspiration or biopsy taken in the premenstrual phase can be histologically dated. This procedure is still one of the initial outpatient

investigations in developing countries where genital tuberculosis is a significant problem. Alternatively, it can be carried out in conjunction with laparoscopy under general anaesthesia. If the endometrium in the second half of the menstrual cycle is found to be in a secretory phase, it can be presumed that, during that cycle at least, the woman ovulated. A diagnosis of luteal phase defect can be made if the endometrium is 2–3 days out of phase from the day of cycle on repeated biopsy but this is not always accurate. Cured material is also sent for bacteriological evaluation for acid-fast bacilli. Polymerase chain reaction (PCR) for *M. tuberculosis* can be done in selected cases depending on the clinical profile.

### Tubal Patency Tests

These are best carried out between the seventh to tenth day of the cycle. At that time there is practically no risk of disturbing a fertilised ovum. The risk of embolism and of retrograde dissemination of infection and endometriosis makes it imperative not to carry out the tests while any uterine bleeding is taking place and for 2 days afterwards.

### Hysterosalpingography (HSG) (Figs 46.3 to 46.5)

This entails injecting a non-irritant radio-opaque material through the cervix into the uterus and tubes without general anaesthesia in a radiological department.

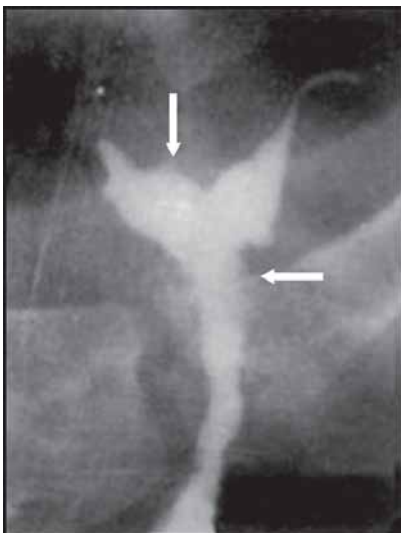


Fig. 46.3: HSG cornual block



Fig. 46.4: HSG mid tubal block



**Fig. 46.5:** HSG unicornuate uterus with patent tube

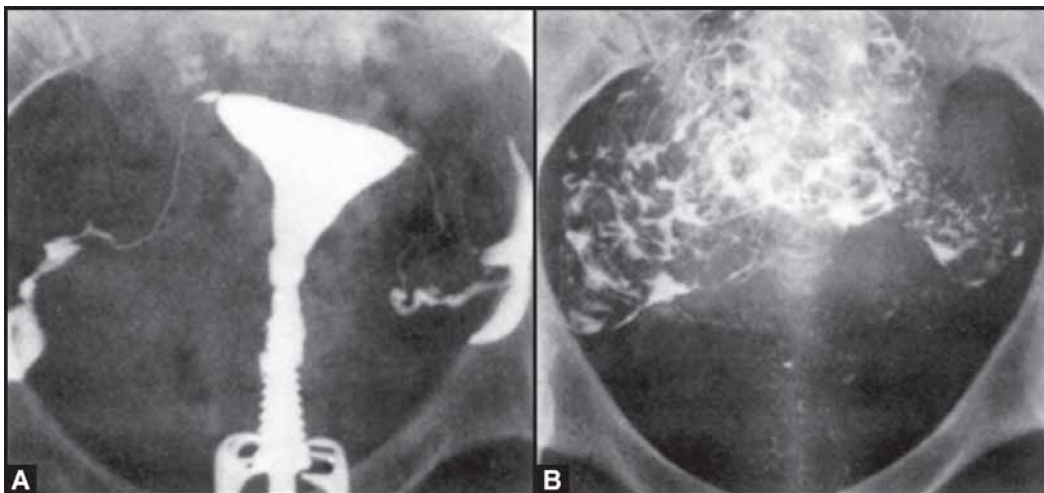
With the cannula in place and the patient lying in the lithotomy position, the radio-opaque material is injected slowly from a syringe, the amount required varying from 2 to 20 ml. The flow through the uterus and tubes is observed by screening, films being exposed at suitable intervals. This relatively simple procedure requires skill and experience to obtain the most instructive radiographs. In not less than 15 per cent of cases in which salpingography shows apparent bilateral tubal obstruction, subsequent events and findings prove the tubes to be normal. False-positive radiographs are

rare but can result if the tubes are unusually long with dilated closed extremities. Administration of atropine or nonsteroidal anti-inflammatory drugs (NSAIDs) before the procedure decreases false-positive results caused by cornual spasm.

It must be kept in mind that screening of the patient and the taking of no more than two radiographs involves some radiation exposure to the ovaries. To reduce this risk to a minimum, an image intensifier should be connected to a closed-circuit television screen.

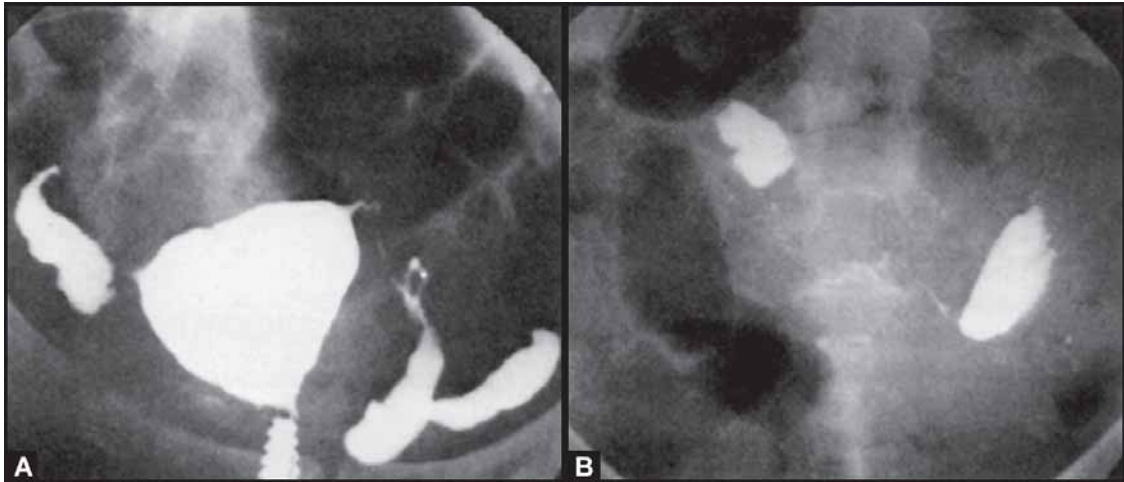
The media presently used for injection are usually water-soluble, e.g. diatrizoate (Hypaque 60) or iothalamate (Conray 60). These are the least dangerous but they are quickly absorbed and are of less value in diagnosing peritubal adhesions than the older oily preparations, e.g. ethiodal. After screening, a film is taken; this and a repeat film 20–30 minutes later reveal all the necessary information (with oily preparations, delayed films were also taken). Sometimes the medium is seen to loculate in the pelvis; this is a valuable pointer to a diagnosis of peritubal adhesions which interfere with the tubo-ovarian pathway (Figs 46.6 to 46.9).

Hysterosalpingography not only indicates the state of each tube and reveals the site of any obstruction (Figs 46.9C and D), it also provides information about the uterine cavity (Fig. 46.9E). There may be some therapeutic benefit in the first few cycles following the procedure but this is seen more often with oil-based dyes which can displace the debris.

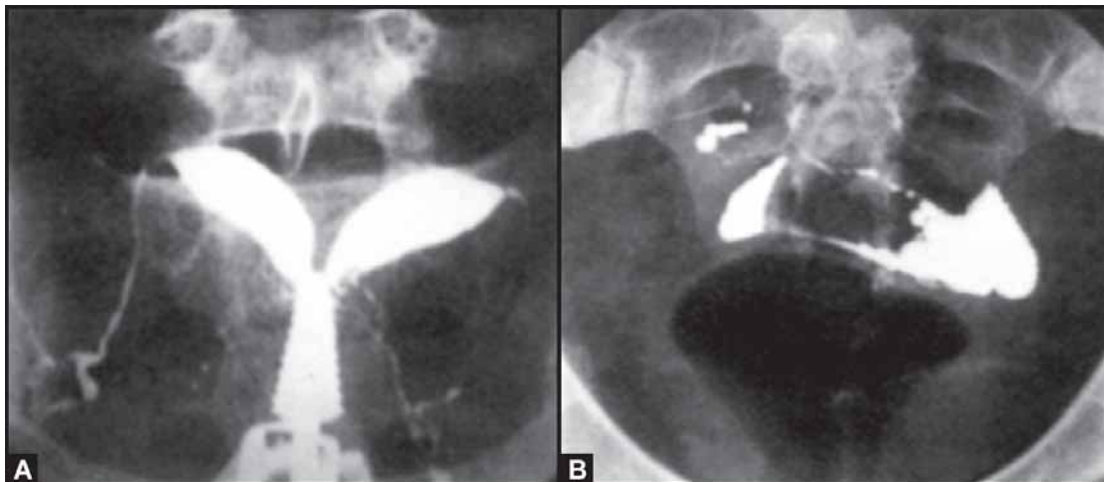


**Figs 46.6A and B:** Hysterosalpingography showing normal tubal patency. An oily radio-opaque dye was used, (A) The initial injection shows a normal uterus except for a poor isthmic constriction. Each outer tubal junction shows a ring of muscle spasm which is a common and insignificant finding. Both tubes are patent and the medium is escaping into the peritoneal cavity, (B) A straight radiograph taken 24 hours later shows that the medium is freely disseminated in the pelvis





**Figs 46.7A and B:** Hysterosalpingography showing both tubes obstructed at their outer ends and a uterine cavity which is slightly enlarged and irregular in shape as a result of small leiomyomas. The patient in this case complained of infertility and gave a history of contact with tuberculosis in adolescence. Tubal patency tests were therefore avoided until the endometrium was proved bacteriologically negative for this disease. Ultimately, however, tubercle bacilli were cultured from the tubes, (A) Radiograph at the time of injection shows dilated and closed outer ends of the tubes, (B) The medium is retained in the tubes 24 hours later

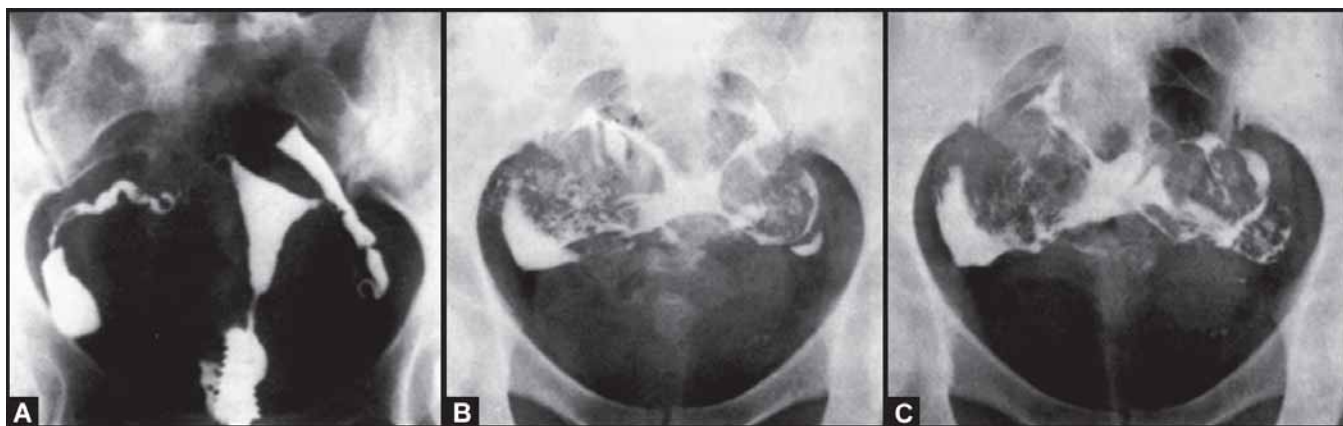


**Figs 46.8A and B:** Hysterosalpingography in the case of a woman aged 28 years who complained of infertility following the birth of her first child 4 years previously. The labour was complicated by adherence of the placenta which had to be removed manually, (A) This radiograph shows the uterus to be bicornuate (hence the trouble with the third stage of labour), and the right tube closed at its outer end which is the site of a small hydrosalpinx. The left tube is doubtfully patent, (B) This radiograph taken 24 hours later shows the small hydrosalpinx on the right with loculation in the pelvis of medium which passed through the left tube. This means peritubal adhesions dating from puerperal infection

*Hysterocontrastsonography (HyCoSy)*

In this technique, a combination of air and saline or contrast medium (Echovist-200) is introduced into the uterus transcervically. The flow of the medium seen in some unanaesthetised women is more through the

uterus and tubes, and its spill into the pelvis with water-soluble than with oily or non-ionic media is monitored by ultrasound. This procedure may have certain complication like immediate pain, vomiting and may have hypotension and shock due to manipulation with instruments leading to vasovagal problems.



**Figs 46.9A to C:** The diagnosis of intrapelvic adhesions by hystero-salpingography. (A) An apparently normal hysterosalpingogram showing both tubes patent, (B) A film exposed 24 hours later shows some spread, but an unusual distribution, of the medium in the pelvis, (C) A radiograph taken 8 days later shows an almost identical distribution of the medium, strongly suggesting that its dissemination is impeded by adhesions

**Embolism, intravasation:** The frequency of gas embolism is unknown because it is usually subclinical and passes unrecognised. It presumably equals that of intravasation of radio-opaque material, which occurs in 1-2 per cent of women subjected to hysterosalpingography (Figs 46.10A to E). In this respect oily preparations are more dangerous than aqueous ones because they cause embolism. While screening, entry of the medium into the veins can be visualised during injection and an embolism recognised at once; the injection can then be discontinued.

The occurrence of intravasation should always raise the possibility of endometrial tuberculosis and, if the tubes are also obstructed, it is almost diagnostic of this disease.

Intravasation is sometimes into lymphatics and not blood vessels (Fig. 46.10E). The resulting picture is typical and, if radiographs are taken 24 hours later, collection of the medium in the pelvic lymph nodes is often demonstrable. This accident is of interest but not serious. The same is true when, at the time of laparoscopy, dye injected through the cervix enters the circulation to produce a blue uterus and subsequently blue urine.

**Peritoneal reaction and infection:** Pelvic peritonitis and salpingitis follow hysterosalpingography in 0.5-1.0 per cent of cases. The infection is not usually introduced at the time of the injection but represents an exacerbation of a previously dormant salpingitis. Prophylactic antibiotics should be administered if tubal disease is discovered.

**Generalised sensitivity reaction:** Reactions can occur to chemicals such as iodine which may be in the medium. The new non-ionic materials are safer in this respect but are more expensive.

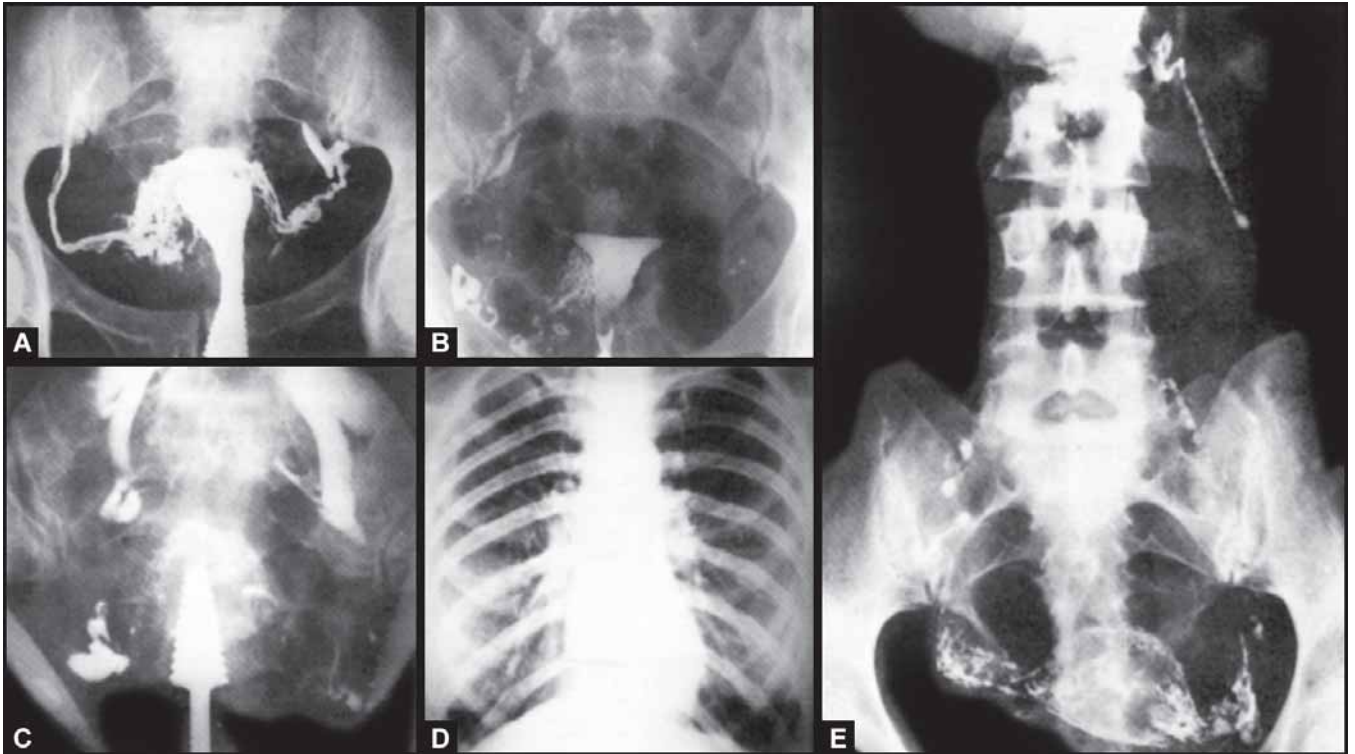
**Abortion:** Unless care is taken, and especially when the patient has an irregular menstrual cycle, it is easy to carry out a tubal patency test in the presence of an early pregnancy. This is the reason that the 10-day rule (no X-rays after day 10 of the cycle) should be rigidly applied in infertility investigations.

#### *Contraindications to Tubal Patency Tests*

In view of the above considerations, tubal patency tests are to be avoided during and immediately before menstruation, after curettage, when there is a history of recently active salpingitis, if there is any reason to suspect the presence of active tuberculosis of the genital tract, and when there is evidence of infection of the lower genital tract, such as a purulent discharge.

#### *Hysteroscopy and Laparoscopy*

In many centres, hysteroscopy and laparoscopy are now used as the principal methods of assessment of the pelvic organs and of tubal patency. Instillation of a dye, e.g. methylene blue through a balloon catheter or cannula in the cervix (chromopertubation) permits direct visualisation of its path through the tube and the exact site of block, if any. The fimbriae can be visualised directly and spill of the dye from each side confirmed.



**Figs 46.10A to E:** Some examples of extravasation of the medium during hysterosalpingography, which happens in at least 1 per cent of cases despite all precautions. It rarely has serious consequences if screening is employed because this allows the injection to be stopped immediately. In any case safety is provided by the fact that no more than one ampoule of the radio-opaque fluid (20 ml) is injected. Intravasation with gas during insufflation is potentially more dangerous because the volume is often not controlled or restricted, (A) The medium enters the wall of the fundus of the uterus and drains into the ovarian veins, (B) Medium entering the pampiniform plexus and draining via the internal and common iliac veins. Its oily nature is illustrated by its forming globules in the blood, (C) Medium diffused through the vessels of the cervix and draining into the internal iliac veins, (D) The same case as (C) showing evidence of oil emboli in the lungs several hours later; the patient remained asymptomatic, (E) Lymphatic intravasation. This radiograph was taken 24 hours after salpingography and shows the medium diffused through the lymphatics of the uterine wall and broad ligament; it is also in the main trunks leading to the para-aortic nodes. The medium is slow to clear from lymphatics but clears from veins within seconds or minutes

As the procedure is done under anaesthesia, cornual spasm as a cause of false tubal blockage is excluded. Intrauterine lesions and peritoneal and pelvic factors are better demonstrated by the simultaneous use of hysteroscopy and laparoscopy; in many cases operative correction can be carried out at the same time.

The expense and limited availability of these techniques does not permit their universal use for initial evaluation.

Hysteroscopy should, however, be considered *mandatory* if the following are suspected on HSG or on transvaginal sonography: an intrauterine lesion, e.g. leiomyoma or endometrial polyp; a congenital uterine anomaly; intrauterine adhesions because of past history

of uterine curettage, complicated forceps delivery, severe pelvic inflammatory disease, puerperal sepsis or recurrent miscarriage; and, in women undergoing *in vitro* fertilisation (IVF), failure of implantation of embryos after 3 cycles.

Similarly, *laparoscopy is warranted where* history or physical examination suggests the presence of pelvic disease, endometriosis, in cases of unexplained infertility or where HSG suggests tubal block or peritubal adhesions. However, neither hysteroscopy nor laparoscopy can provide information about internal tubal architecture and hysterosalpingography is indicated if, for example, salpingitis isthmica nodosa is suspected.

Salpingoscopy can evaluate internal tubal anatomy but is not widely available as a clinical service. The falloposcope can be introduced through the laparoscope as well as transcervically.

On laparoscopy, an infertility factor will be found in 30–50 per cent of women previously regarded as having normal genitalia. The unexpected findings are commonly peritubal or periovarian adhesions, and endometriosis. Laparoscopy should be delayed unless symptoms indicate pelvic pathology, as many couples conceive with preliminary reassurance and simple investigations within 6 months of being seen for advice and investigation. Premature diagnosis of minimal endometriosis, for example, may hinder fertility prospects rather than aid them by resulting in 6–9 months' 'contraceptive' hormone treatment being given.

At the time of laparoscopy the patency of the tubes is confirmed by injecting dye through the cervix and watching its passage along the tubes and through the abdominal ostia (Fig. 46.11).

The dye used in laparoscopy may produce a chemical peritonitis, but this is transient and settles as the dye disperses. Therapeutic procedures like division of adhesions, salpingostomy, ovarian cystectomy or fulguration of endometrial deposits can be undertaken at the same time. This may necessitate the use of additional puncture sites or ports. Detailed documentation of all the laparoscopic findings and the procedure executed is important for proper management subsequently. Video recordings can also be made and provided to the patients.



Fig. 46.11: Blocked tubes

### The Postcoital Test

The postcoital test is a simple clinical test of the sperm-cervical mucus interaction.

Mucus is removed from the *cervix* with a nasal polyp forceps, a pipette or a tuberculin syringe and examined at various times after coitus (*Sim's test*, *Huhner's test*), to see if the mucus is invaded by spermatozoa and whether they retain their activity. The test must be carried out at the time of ovulation because at other times the cervical mucus is normally unreceptive. The pre-ovulatory cervical mucus is normally thin, clear, abundant and stretchable (spinnbarkeit >8–10 cm) with good tertiary ferning and low cellularity.

There is no agreement as to the criteria for a satisfactory result. Examinations are advised within 2–8 hours of coitus; the number of spermatozoa and the extent of their motility which should be found in the mucus at those times are matters of opinion. Some authorities say that normally, 2–8 hours after coitus, 15 spermatozoa are found in each high-power field and that these show progressive, not rotatory, activity. However, the results of the postcoital test correlate poorly with the pregnancy rates. Any purposeful forward progression should be regarded as a positive test, whereas the finding of no sperm, all dead sperm, less than 3 motile sperm per high power field and sperm shaking without progression should suggest the presence of an immunological factor (or the use of vaginal lubricants). These patients can be evaluated by sperm function tests (*see above*).

The value of postcoital testing of cervical mucus for the presence of motile sperm is controversial and is a subject of continuing debate. The routine use of postcoital testing of cervical mucus in the investigation of fertility problems is not recommended because it has no predictive value on pregnancy rate.

### Screening for Chlamydia Trachomatis

*Chlamydia trachomatis* is present in 11 per cent of the sexually active population aged 19 years or less. It is a major cause of pelvic inflammatory disease, leading to chronic abdominal pain, ectopic pregnancy and tubal factor infertility. Asymptomatic chlamydial infection may go unrecognised and untreated. Both doxycycline and azithromycin are effective prophylaxis and treatment for chlamydia. There is evidence that screening for and treating cervical chlamydial infection can reduce

the incidence of pelvic inflammatory disease in women at increased risk of chlamydia. Prophylactic antibiotics should be considered before uterine instrumentation if screening has not been carried out. Tubal disease includes tubal obstruction and pelvic adhesions due to infection, endometriosis and previous surgery. Endometriosis accounts for about 5 per cent of female infertility. The diagnosis and severity of endometriosis are established by laparoscopy. However, disease severity has not been shown to predict the chance of pregnancy. It has been found that the women with positive chlamydia have more of distal tubal problems and hence it may be worth while considering a diagnostic laparoscopy for those women who have positive chlamydia testing so that delay in the management is not present. Elevated titres of chlamydial antibodies in women are significantly associated with tubal disease.

### TREATMENT

The object of treatment is to eliminate as far as possible, any infertility factors found in either husband or wife. Systemic diseases and other obvious diseases in the genital tracts are treated. The benefits of treatment for minimal endometriosis must be justifiable. In fact, anovulation is the only condition where one can give a good prognosis statistically. In many other instances an explanation of the findings and a defined period of waiting are often more appropriate. Both partners should be considered together because incurable infertility in one can sometimes be cancelled out by raising the fertility of the other.

In about 10–20 per cent of couples, basic investigations are normal and this is the group labelled as unexplained infertility. Sixty to seventy per cent of this group are found to conceive within 3 years without any further treatment.

### Both Partners

#### *Reassurance*

Reassurance may be all that is necessary when couples complain of infertility too soon. They appreciate a simple account of the physiology of conception and an explanation of the fact that the mathematical chances of conception are not as high as they imagined. In all cases *optimism should be the keynote*, tempered with realism, even when the investigations suggest that the prospects for pregnancy are poor.

### *Correction of Coital Difficulties*

Some couples require instruction on the difficulties of coitus, on its timing and spacing. They should *not* be advised to try to time coitus to coincide with ovulation and to conserve their energies at other times. They should follow their natural inclinations but keep in mind that conception is most likely between the tenth and eighteenth days of a 28-day cycle, at which time coitus should be practised at 48-hour intervals.

Change in coital position can be tried in case of mechanical difficulty. Immediately after coitus the wife should rest quietly for 10 minutes to ensure that some semen remains in contact with the cervix though it is doubtful whether this is further encouraged by elevating the buttocks on a pillow.

### *Correction of General Ill Health*

Under this heading are attention to matters such as overwork, anxiety, obesity and intemperance in smoking and drinking. A long carefree holiday may sometimes be the answer.

### The Husband

#### *Impotence and Premature Ejaculation*

*See Chapter 45.*

#### *Defective Spermatogenesis*

The treatment of faulty spermatogenesis is not very satisfactory and the outlook is poor. Attention to general health, obesity and mode of existence offers the best hope. Suspensory bandages and warm tight under-clothing should be avoided, and cold baths encouraged. Any infection in the prostate or other part of the urinary tract should be eradicated. Alcohol and smoking are restricted.

There is no consensus of opinion regarding the treatment of varicocele although this is often done in the absence of other obvious causes of infertility. If treated surgically, care should be taken not to injure the arterial supply to the testes because this makes matters worse; the best technique is to ligate the spermatic vein in the inguinal canal and this can give apparently good results. Laparoscopic surgery and embolisation techniques have also been used. Sperm density is said to continue to rise for 2 years in 80 per cent of cases after surgery for varicocele, and pregnancy rates of 30 per cent

(uncontrolled figures) are reported. Empirical measures designed to improve spermatogenesis include the administration of vitamins E and C which are free radical scavengers, and the administration of doxycycline or erythromycin for subclinical chlamydial infection.

Clomiphene, in a dose of 25 mg daily for 3 months, has been tried in cases of oligozoospermia but without convincing results. The most rational treatment for defective spermatogenesis in proven hypogonadotropic hypogonadism is with gonadotrophins. FSH treatment is specific to the seminiferous tubules. Human chorionic gonadotrophin (hCG) 2000 IU i.m. once or twice weekly is useful in patients with acquired or partial gonadotrophin deficiency. If there is no sperm in the ejaculate after 6-12 months of therapy, hMG is added, starting with 37.5 IU intramuscularly thrice weekly and increasing to 75 IU thrice weekly after 6 months, if required.

Treatment with gonadotrophins or gonadotrophin releasing hormone (GnRH) can stimulate spermatogenesis in cases where the testes are essentially normal and there is clear evidence of a hypothalamic-pituitary failure. Unfortunately, azoospermia and oligozoospermia are usually manifestations of poor testicular function and the tubules are refractory to gonadotrophins.

Most claims on the effectiveness of any sort of medical (and sometimes surgical) treatment are questionable as the quality of semen varies spontaneously from time to time in the same man. So any increase in sperm density is often to be credited to Nature rather than a particular remedy. Glucocorticoids and condoms have been used in men with antisperm antibodies but are of doubtful value.

### *Azoospermia: Classification and Treatment*

Azoospermia is the absence of spermatozoa in the ejaculate. Azoospermia is found on semen analysis in about 5 per cent of all couples being investigated for infertility, and its incidence is 10 to 20 per cent among infertile men who have abnormal semen analysis. Traditionally, azoospermia has been classified as obstructive or nonobstructive. However, an increased understanding of the various aetiologies of azoospermia and treatment advances using surgical sperm retrieval and ART have prompted a reclassification. The classification system, advocated by Sharif and others, may better reflect the aetiology, prognosis, and treatment

of azoospermia. It separates azoospermic patients into those with pre-testicular, testicular, and post-testicular causes.

### *Pre-testicular Azoospermia*

Pre-testicular azoospermia represents those conditions in which the hypothalamic-pituitary axis fails to stimulate spermatogenesis within the testis. Congenital, acquired, and idiopathic aetiologies of hypogonadotropic hypogonadism are included in this category. A full endocrine history, including information on puberty and growth and a review of endocrine systems, should guide the physician in the evaluation of the hypogonadotropic hypogonadal patient. Laboratory investigations of particular benefit in this population include measurement of serum LH, FSH, testosterone, and prolactin levels and imaging of the pituitary gland. Low levels of gonadotropins (LH and FSH) and low serum levels of testosterone are characteristic.

Hormonal treatment of hypogonadotropic hypogonadism has been conclusively demonstrated to be efficacious. In fact, pulsatile gonadotropin-releasing hormone (GnRH) therapy is both conceptually indicated and effective in infertile men with hypothalamic dysfunction, including those patients with Kallmann's syndrome. Infertile males with hypogonadotropic hypogonadism secondary to panhypopituitarism also may respond to GnRH therapy. An alternative treatment uses human chorionic gonadotropin (hCG), 1,000 to 2,500 IU twice a week, with the dose titrated to maintain serum testosterone and oestradiol levels within the normal range. Treatment with hCG is then combined with human menopausal gonadotropin (hMG), which is given at a dose of 150 IU three times weekly. Spermatogenesis and pregnancy can be achieved in up to 80 to 88 per cent of patients after 1 year of therapy.

### *Testicular Azoospermia*

Gonadal failure is the hallmark of testicular azoospermia. Causes of this condition may be congenital or genetic (e.g., Klinefelter's syndrome, microdeletion of Y chromosome), acquired (e.g., radiation therapy, chemotherapy, testicular torsion, or mumps orchitis), or developmental (e.g., testicular maldescent). The latter disorder may be associated most closely with male factor infertility in the absence of complete testicular azoospermia. A large observational cohort study suggested that infertility

was, in fact, associated with congenital bilaterally maldescended testes, but that men with congenital unilaterally maldescended testes did not have decreased fertility when compared with controls.

Men with hypergonadotropic hypogonadism (elevated levels of LH and FSH with low serum levels of testosterone) generally have primary gonadal failure. A karyotype should be obtained in such cases to detect chromosomal abnormalities such as Klinefelter's syndrome (47, XXY). Acquired causes of primary gonadal failure are usually evident on history, but they should be confirmed by assessment of the serum hormonal profile and biopsy. If the diagnosis of gonadal failure is confirmed on biopsy, endocrine therapy is contraindicated.

It is becoming increasingly evident that some cases of male factor infertility that have previously been categorised as idiopathic are actually the result of genetic defects on the Y chromosome. The two most commonly implicated candidate gene families are the RNA-binding motif (RBM) and the "deleted in azoospermia" (DAZ) families, but microdeletions at various loci on the Y chromosome have been described. For example, microdeletions in Yq11.23 have been found in 10 to 20 per cent of men with idiopathic azoospermia or severe oligospermia. Interestingly, 2 per cent of fertile men also have microdeletions in the Y chromosome. These microdeletions can be transmitted to the male offspring, who may then also suffer from infertility. Therefore, screening for genetic causes is indicated in nonacquired cases of testicular azoospermia so that proper genetic counselling can be provided before treatment. Treatment is focused on surgical retrieval of spermatozoa with subsequent fertilisation of the oocyte by ICSI. These approaches have made fertility possible for some men with testicular azoospermia.

#### *Post-testicular Azoospermia*

In post-testicular azoospermia, the hypothalamic-pituitary axis and spermatogenesis are normal. No sperm appear in the ejaculate secondary to congenital absence or obstruction of the vas deferens or ejaculatory ducts, acquired obstruction of these ducts, or ductal dysfunctions, including retrograde ejaculation. Although low seminal pH or low seminal fructose may signal the congenital absence or obstruction of the vas deferens,

the diagnosis is confirmed by vasography. In some cases, testicular biopsy may be indicated to differentiate between primary testicular damage and outflow obstruction. Congenital bilateral absence of the vas deferens (CABVD) is found in 1 to 2 per cent of infertile men and 95 per cent of men with cystic fibrosis. Common mutations of the cystic fibrosis transmembrane conductance regulator gene (CFTR), which encodes a cyclic adenosine monophosphate (cAMP)-regulated chloride channel, can be found in some infertile men with CABVD, despite the absence of clinical symptoms of cystic fibrosis. Therefore, screening for mutations in the CFTR gene is indicated if men with CABVD plan to undergo sperm retrieval and ICSI in order to conceive using their own sperm. One cost-effective screening method addressing this problem involves screening the female partner for the three most common mutations in the CFTR gene. If negative, the couple has a risk of less than 1 in 1,500 for conceiving a child with cystic fibrosis, regardless of the paternal genotype.

#### *Azoospermia Caused by Obstruction of the Epididymis or vas*

The outlook in these cases is not completely hopeless and operations, e.g. vasovasostomy and transurethral resection of ejaculatory ducts (TURED), if carried out by an experienced surgeon using microsurgical technique, are occasionally successful. TURED is an outpatient procedure for ejaculatory duct obstruction. Intrauterine insemination of spermatozoa obtained by aspiration of the testis always fails because their maturation is incomplete until after they have left the gonad. Intracytoplasmic sperm injection may offer some hope to these patients (*see below*).

#### *Prevention of Male Infertility*

In this respect two matters deserve mention: the efficient and early treatment of cryptorchidism; and the treatment of orchitis complicating mumps and other virus infections. If tension in the testis is reduced by incision of its capsule *early* in the course of orchitis, the ischaemia which causes tubular necrosis may be prevented. Treatment with massive doses of hydro-cortisone is less likely to be effective. Vaccination against mumps in childhood may protect against postpubertal mumps orchitis.

## The Wife

### Medical Treatment

**Hormone therapy:** The only clear indication for hormone therapy is a proven failure of ovulation. In practice this generally means infertility which is associated with amenorrhoea or oligomenorrhoea. Even in such cases ovulation can never be induced unless the ovaries contain ova capable of being stimulated. In such cases, the appropriate treatment is with clomiphene or similar preparations, bromocriptine, human gonadotrophins or GnRH. The details of these treatments are described in Chapter 5. Gonadotrophin therapy requires detailed investigation to establish that the treatment is indicated followed by strict ultrasound and laboratory control if complications, including multiple pregnancy, are to be avoided. All treatments to induce ovulation should usually be limited to six to nine proven ovulations, since the majority of successful conceptions occur within this time.

In general, women under the age of 25 years who fail to conceive within 6 cycles and women over the age of 25 years who do not do so in 12 cycles should be offered assisted reproduction (usually IVF).

The empirical administration of clomiphene to women in whom there is no reason to suppose a failure in ovulation is justified only in cases of unexplained infertility. Some of these patients may have mild alterations in hormone levels commensurate with decreased ovarian reserve. Super-ovulation achieved by the use of gonadotrophins and GnRH analogues coupled with IUI of washed sperm have been shown to achieve a cumulative pregnancy rate of 40 per cent in 6 cycles and is a cheaper alternative to IVF. However, there are reports of a possible increase in the incidence of ovarian cancer in women who received ovulation induction for more than 12 cycles; the relative risk is reportedly higher in cases of unexplained infertility than of anovulation. Patients should be made aware of these reports, and, for this reason also, ovulation induction should be restricted usually to 6 cycles. However, the reports of a possible increase in the ovarian cancer in women who received ovulation induction for more than 12 cycles is controversial but needs to be taken into consideration. Hence the induction of ovulation should not be done for a long periods.

The empirical use of sex hormones is useless. Oestrogens in the first half of the cycle do not overcome

*supposed* uterine hypoplasia nor do they make cervical mucus more receptive; progestogens premenstrually cannot prevent an early abortion or improve an unreceptive endometrium or poor corpus luteum function. None of these conditions is a proven cause of infertility and there is no scientific evidence to show that such remedies do any more than give the patient hope. Patients receiving clomiphene who have poor luteal function may benefit from hCG support started in the second half of the cycle and continued through the first trimester.

The administration of an oestrogen-progestogen antiovarian preparation for a few months, in the hope that the subsequent rebound activity of the hypophysis and the ovaries will favour conception, is also to be deprecated. It is not only unscientific and clearly proven to be followed by no more pregnancies than can be expected by chance, it also often delays the search for the real cause of infertility and may permanently depress hypothalamic—pituitary function.

### Bromocriptine

See Chapter 5.

## Operative Treatment

### *Dilatation of the Cervix, Tubal Insufflation, Hysterosalpingography and Laparoscopy*

These procedures, although primarily diagnostic, are often said to have a definite if small therapeutic value. Some women conceive within a few months of having them carried out. Caution is necessary in assessing the results, for in the absence of abnormalities conception would be expected to occur anyway and the successes almost certainly reflect an ongoing cumulative pregnancy rate. In all cases the use of invasive tests which have the risk of introducing infection, apart from any risk associated with general anaesthesia, should be balanced against the need for establishing a diagnosis. As conception may occur without the need for detailed investigation, a waiting time for laparoscopy and chromotubation of 6-9 months from the time of the couple's first visit is usually reasonable if the couple is young and newly married.

### *Reconstruction Operations on the Tubes*

When both fallopian tubes are found closed, the prognosis is poor but not hopeless; it depends on the



site and extent of the obstruction, and on the lesion causing it. Disorganisation of the lumen for a long distance, and multiple obstructions, offer little hope. Treatment is not based on the causative agent, which is often unknown or not determined, but on the end result of the infection, namely the appearance of the tubes. Salpingostomy often gives disappointing results because the endosalpinx is usually so damaged that, even if the artificial stoma remains open, the tube is devoid of ciliary and peristaltic function.

The cases most suitable for reconstruction operations are those in which the blockage is caused by previous pelvic peritonitis of appendicular or puerperal origin; a mild gonococcal or chlamydial infection with only a tiny hydrosalpinx; peritubal adhesions; obstruction at the isthmus by endosalpingiosis or localised salpingitis; and surgical injury (including sterilisation operations). Careful choice of cases, analysis and evaluation is therefore essential to obtain even moderately good results with microsurgery. Many of the surgical procedures can now be done laparoscopically. Although it is not clear whether pregnancy rates are better with the laparoscopic techniques, they do reduce hospital stay and recovery time resulting in fewer postoperative adhesions with better healing.

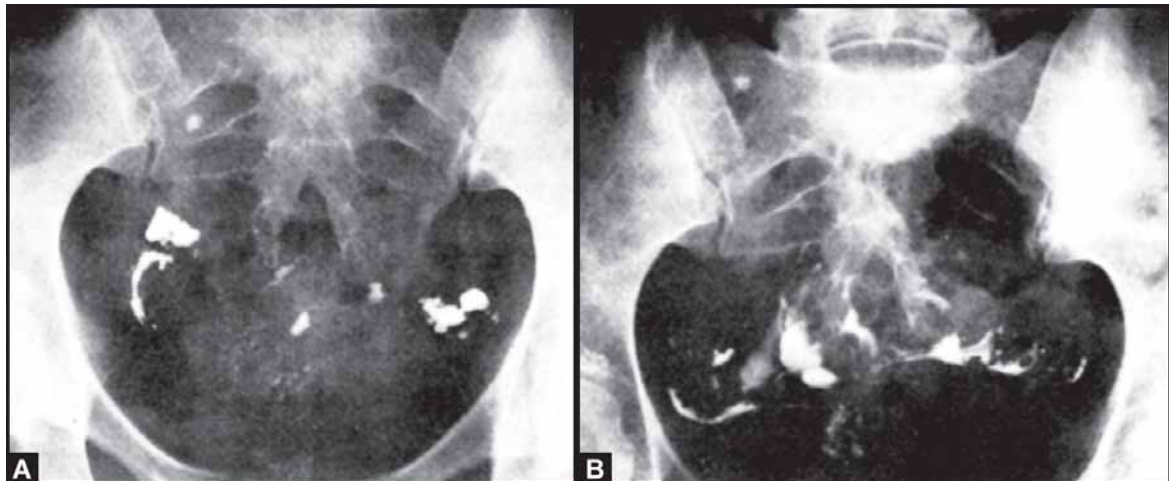
Surgery should generally be restricted to women aged less than 37 years in whom there is no other apparent treatable cause for infertility (i.e. no absolute

bar to conception) and whose husbands are highly fertile. All patients should be aware of the success rates in general and especially those of the surgeon performing the operation; the risks of the surgical procedure itself; and the increased chance of subsequent ectopic pregnancy, which occurs in approximately 10-15 per cent of conceptions. The substantial failure rate of tubal surgery is the consequence of intratubal ciliary and epithelial damage which cannot be assessed preoperatively or corrected during the operation.

Possible procedures are as follows:

**Salpingolysis and fimbriolysis:** This involves only the separation of peritubal and periovarian adhesions, and gives good results (Figs 46.12A and B). The reported subsequent pregnancy rate is as high as 30-40 per cent. This procedure can also be done laparoscopically.

**Reimplantation of the tube:** Excision of a damaged isthmus with implantation of the remaining healthy part of the tube into the uterus is followed by pregnancy in 10-20 per cent of cases. This operation is still well worthwhile undertaking, where facilities for IVF do not exist, provided that the outer portions of the tubes are healthy. The obstructed portion of the tube is excised and the outer portion of the tube is implanted at the cornu to maintain the anatomical uterotubal junction. The use of splints, once routine, is now considered optional. If they are inserted, they are usually pulled out from below after a few weeks.



**Figs 46.12A and B:** Salpingolysis for pelvic adhesions causing infertility by interfering with the tubo-ovarian pathway; their cause was a pelvic abscess secondary to acute appendicitis, (A) A radiograph taken 24 hours after salpingography showing loculation of the medium as evidence of peritubal adhesions, (B) A similar radiograph obtained in the same case 3 months after separation of adhesions and salpingolysis. The medium now spreads more freely, although there is still some loculation

In the event of subsequent pregnancy, it may be wiser to deliver the patient by elective caesarean section because of possible weakness of the uterine wall at the implantation sites. I have, however, delivered several such patients vaginally without mishap.

Hysteroscopic transcervical cannulation of the tubes has been used in cases of proximal tubal obstruction. This method has been successful in cases where there is no significant pathology but if there is endosalpingiosis or infection, this method cannot be curative. It involves the introduction of a 3-French Teflon catheter through the ostia aided by a 5.5-French outer cannula and a stainless steel guidewire. Pregnancy rates vary from 54-60 per cent, being lower if there are associated adhesions. This technique has also been used to develop the technique of falloposcopy, for transcervical placement of gamete and embryos (*see below*) and for intratubal insemination.

**End-to-end anastomosis:** Without microsurgery facilities, this is usually carried out over a threaded nylon splint into the uterus, and is usually the best means of dealing with tubes whose middle portions have been obstructed or removed by a previous sterilisation procedure. The splint is often removed at the end of the operation. In such cases the remaining portions of the tube are healthy, so a success rate as high as 50 per cent is possible. Using microsurgical techniques a splint is not essential, even during the operation, and success rates of up to 70-80 per cent have been reported for sterilisation reversal operations.

Results depend on the site of anastomosis and the residual length of the ampullary end. Isthmic-isthmic anastomosis when there is no tubal or muscular disparity gives the best results. Isthmic-ampullary anastomosis involves the approximation of lumina with different diameters. The common practice is to split the isthmic end longitudinally to increase the lumen artificially. It is usually preferable to exclude the mucosa while placing sutures, as these can cause an inflammatory endosalpingitis. However, the muscularis in the region of the ampulla is thin and it is often necessary to penetrate the lumen to get an adequate bite. Ampullary-ampullary anastomosis is rarely required. A residual ampullary length of less than 4 cm has been shown to be associated with poor chances of pregnancy and such patients will do better with IVF.

**Salpingostomy:** The creation of a new stoma in the outer end of a completely closed tube is not difficult but, for reasons mentioned previously, is not often followed by pregnancy. Success rates as high as 25-50 per cent are reported. Various techniques are employed; in all these, gentle handling of the tissues, accurate suturing and haemostasis, preferably using microsurgical techniques, are important. For large hydrosalpinges it is sometimes best to open the tube longitudinally for a considerable length, hoping that the stoma will remain open in some part (*gutter salpingostomy*).

For smaller hydrosalpinges and for closure only of the ampulla, the *stoma* is best created at the outer end of the tube and the edges rolled back to form a cuff salpingostomy or modified fimbria. Even so, in the absence of fimbria the new ostium often closes and a hydrosalpinx reforms.

The figures quoted above are those obtained by experts in these particular procedures, who also claim an overall pregnancy rate of 50 per cent for all types of reconstruction operations. However, the average gynaecologist cannot achieve more than the occasional success. The only exception to this is where end-to-end anastomosis operations are carried out on normal fallopian tubes following sterilisation operations. In these cases, especially where the Pomeroy technique, Fallope rings or Hulka clips are used for sterilisation, success rates of 70-80 per cent are obtainable. There also appears to be a lower ectopic pregnancy rate.

All reported results need to be accepted with reserve. Sometimes the successful operations have been unilateral, the other tube being patent; sometimes salpingolysis is recorded as salpingostomy. Many tubal implants have been undertaken on completely normal tubes, spasm having been mistaken for organic obstruction during tubal patency tests.

Despite all the inherent surgical risks and complications that may occur if conception occurs, these operations are cheerfully accepted by the woman whose main concern is to have a baby. In all cases the patient should be aware of the probable success rate as judged by pregnancies achieved before the operation. Laparoscopic surgical and microsurgical techniques now offer a better outcome but the limiting effects are a damaged endosalpinx and distorted tubo-ovarian relationships due to adhesions which may occur, or recur, post-operatively.

### *Correction of Uterine Position and Malformations*

Retroversion and retroflexion can usually be neglected as causes of infertility until all other possibilities have been excluded; when this is so, however, the correction of the displacement is worthwhile. This is usually done by means of a Hodge pessary but occasionally it may be appropriate to correct the position by ventrosuspension during surgery for pelvic adhesions or endometriosis.

The management of congenital malformations of the uterus is discussed in Chapter 13.

### *Laparoscopic Ovarian Diathermy*

Laparoscopic ovarian diathermy or drilling (LOD) using unipolar cautery or laser is a useful alternative to gonadotrophins in those patients who fail to respond to clomiphene; those who persistently hypersecrete LH; those who live in remote places and cannot be intensively monitored for gonadotrophin therapy; those who cannot afford or tolerate gonadotrophin therapy; those who need laparoscopic assessment of the pelvis.

This procedure has replaced wedge resection of the ovaries and increases the chances of unifollicular ovulation. Although the results are as good as those with gonadotrophins, there is a risk of postoperative pelvic adhesion formation in approximately one-fifth of patients. It has been suggested that the number of punctures be minimised, varying from 4 to 20 per ovary. Peritoneal lavage at the end of the procedure has also been correlated with a decreased incidence of adhesion formation. There is a risk of premature ovarian failure if overcauterisation is done. Increased risk of ovarian cancer, if any, is not yet known.

The effects are usually temporary.

### *Prevention of Female Infertility*

Consideration of the causes of female infertility reveals that some of them are preventable, particularly infections causing tubal occlusion. The elimination of gonorrhoea and chlamydial infection, and of injuries and infections sustained at the time of abortion and labour, could have a significant effect on the problem.

## **ASSISTED REPRODUCTIVE TECHNOLOGY (ART)**

Assisted reproductive technology is not new. Even in mythology there is reference to surrogacy and artificial insemination. Certainly artificial insemination has been

practised for the last century. Assisted reproduction techniques have been established in animal husbandry. Many of the concepts have been derived from Nature itself, e.g. cryopreservation which is practised by certain insects who use sugars and sugar-alcohols as cryoprotectants to withstand sub-zero winter temperatures; this led to the use of glycerol in animal husbandry. However, the birth of Louise Brown in 1978 in Oldham was the first real major step forward. In the words of Mr Patrick Steptoe it was 'the end of the beginning, not the beginning of the end'.

### ***In vitro Fertilisation and Embryo Transfer***

Following success in the veterinary world, this was developed as an alternative treatment for women with severely damaged or occluded fallopian tubes. It is now used for other indications, including long-standing unexplained infertility, treated endometriosis, male factor infertility, cervical hostility and, rarely, after therapy for female cancer. Even though there are an increasing number of centres throughout the world with over half a million babies born by IVF, it remains a very limited service as it is expensive, very specialised and requires good laboratory facilities and a team of skilled workers.

The technique has been immensely refined and new developments are continually taking place. Superovulation is stimulated by the use of clomiphene and/or gonadotrophins so that several ova can be harvested. GnRH agonists are increasingly used for downregulation of the hypothalamic-pituitary-ovarian axis and have been instrumental in increasing the number of oocytes retrieved, improving endometrial receptivity and clinical pregnancy rates with a reduction in cycle cancellation rates.

### *Controlled Ovarian Hyperstimulation*

A number of controlled ovarian hyperstimulation protocols have been described, but essentially they fall into three categories, depending on whether the patient is a normal responder, a poor responder or a hyper-responder.

For normal responders, the standard *long protocol* is used. GnRH agonists (GnRHa) are administered in the mid-luteal phase of the previous cycle, as follicle recruitment normally starts at this time in response to the falling levels of FSH, oestrogen and inhibin.

Leuprolide 0.1 mg daily subcutaneously or nafarelin 200 µg bd intranasally are the usual choices. The administration is continued throughout the follicular phase till hCG is administered. Gonadotrophins are started after the menses. Monitoring is done by serial ultrasound and hormonal profile, i.e. serum FSH, LH, oestradiol and progesterone.

For poor responders a microdose *flare protocol* can be used. Leuprolide 20 µg subcutaneously bd is started from day 2 or 3 of the cycle. Gonadotrophin administration begins on day 6. Assisted zona hatching may improve the pregnancy rates in this group.

Hyper-responders are usually patients with the polycystic ovary syndrome (PCOS). Here a *coasting protocol* can be used. Administration of GnRHa is started from the third week of the previous cycle. Low-dose gonadotrophins (75 IU/day) are started after the menses. If the serum oestradiol is more than 3000 pg/ml, gonadotrophin is discontinued regardless of follicle size and GnRHa continued. When the level of serum oestradiol falls to less than 3000 pg/ml, hCG is administered.

### Oocyte Retrieval

Oocyte retrieval, previously done at laparoscopy and percutaneously, is now almost exclusively done transvaginally under ultrasonic guidance from a transvaginal transducer. This is the easiest, most accurate and patient friendly method. Rarely, if there is no vaginal probe available, the ovary is inaccessible vaginally or there is vaginal infection, a perurethral oocyte pick-up is done under guidance of a trans-abdominal ultrasound probe. To prevent the ovary from slipping away, sharp, single-use disposable needles are used and suprapubic pressure is applied with the hand or with a special abdominal pressure cuff.

It is generally preferable to make a single puncture in the vagina and in the ovary. Keeping the needle in the ovary, several follicles are aspirated one after the other by careful planning and manipulation. A warmed flushing medium - either Earle's with heparin or warmed normal saline - is used. If the oocyte is not recovered, the follicle is flushed with the solution and aspirated. This procedure is repeated till the oocyte is recovered. Manipulation with the needle tip may help to dislodge the oocyte. After all oocytes have been recovered, flushing fluid and blood collected in the pouch of Douglas are aspirated.

### Insemination

The oocytes are inseminated *in vitro* by fresh or cryopreserved sperm. The technique of semen preparation is described on page 724. Insemination with less than 50000 sperm/egg decreases the fertilisation rate, whereas the risk of polyspermy is increased with more than 500000 sperm/egg. The sperms and oocytes are incubated under controlled conditions. After 16–18 hours they are examined for the presence of 2 pronuclei which confirms fertilisation. The zygotes are returned to the incubator to allow cleavage to the 2–4 cell stage when they are ready for transfer to the uterus.

### Embryo Transfer

Embryo transfer (ET) is carried out 48-50 hours after oocyte recovery, that is, 46-48 hours after insemination. An embryo transfer catheter is used which is flushed with Earle's medium. Two or three embryos suspended in 15-25 µl of fluid are transferred 1 cm from the fundus or lower, i.e. about 5-6 cm from the external os, and the catheter checked to ensure that the embryos have been transferred. The patient is made to lie down for half an hour.

Occasionally it is not possible to negotiate the cervical canal. This may require the use of rigid inserters, Allis forceps, etc. and rarely the patient may require to have the ET done under general anaesthesia.

Post-transfer, the patient receives progesterone vaginal suppositories 50 mg twice daily, or intramuscular progesterone 12.5 mg daily.

### Outcome

A *preclinical abortion* is a pregnancy which ends within 28 days of fertilisation diagnosed by a minimum of two raised β-hCG values. This is reported in 9-16 per cent of pregnancies.

A *clinical abortion* is the spontaneous termination of pregnancy of at least 28 days after oocyte pick-up and is seen in 18-30 per cent of pregnancies.

In general, women with tubal disease, mild and treated endometriosis or unexplained infertility have a better prognosis. Increasing female age, antisperm antibodies and sperm dysfunction affect success rates adversely.

A better prognosis is seen in women who return for a repeat attempt at IVF after having delivered a live infant following an IVF cycle; and in women who have

had an unsuccessful pregnancy in the first cycle, whether a miscarriage, an ectopic or a biochemical pregnancy, as compared to a woman who did not conceive at all in the first cycle. The overall clinical pregnancy rate is about 26 per cent per retrieval. The live-birth rate varies from 9 to 26 per cent per cycle, the overall rate is 21 per cent. Of these, 66-72 per cent are singleton, 22-24 per cent twins, 26 per cent triplets and less than 1 per cent are higher-order multiple pregnancies.

Pregnancy rates with 1, 2, 3 and 4 embryos transferred are 9.6, 15.9, 24.2 and 30.6 per cent per cycle, respectively, but the multiple pregnancy rate is also correspondingly increased.

The cumulative conception rate (CCR) up to 35 years of age compares favourably with rates in the normally cohabiting fertile population. After 6 cycles of IVF, CCR reported from the best centres varies from 56 to 72 per cent, whereas in the normal population it is about 55 per cent.

Vanishing foetuses are seen in 18 per cent of cases, ectopic pregnancy is reported in 4-6 per cent. Patients undergoing IVF-ET are at risk of ectopic pregnancy because of the following reasons:

- *Pre-existing tubal damage:* It was the practice earlier to occlude the tubes completely at laparoscopy to prevent subsequent ectopic pregnancy but now, with ultrasound-guided oocyte retrieval, laparoscopy is no longer mandatory. Moreover, bowel adhesions to the tube after diathermy impair oocyte recovery and the procedure does not prevent interstitial pregnancy.
- Multiple embryo transfer
- *Technique of transfer:* Increased volume of transfer fluid, use of excessive force in the transfer, placing the ET catheter beyond the mid cavity or into the tube itself
- Retrograde migration of embryos to the tubes.

Bilateral tubal pregnancy is the rarest form of binovular twins. More commonly the twin sacs are seen in the same tube or there may be simultaneous intra- and extrauterine gestation. In women undergoing IVF, the presence of an intrauterine gestation sac on transvaginal ultrasound (TVS) does not rule out an extrauterine pregnancy, which may be located in the cervix or the ovary.

Maternal complications include those of (1) ovarian hyperstimulation; (2) oocyte retrieval; and (3) embryo transfer. In the first category is the ovarian hyperstimulation syndrome (*see* Chapter 5) which is seen in 1

per cent of women undergoing superovulation, and ovarian cyst formation which is seen during down-regulation with GnRHa or as a result of previous gonadotrophin therapy. It usually settles with continued administration of GnRHa. There have been a few reports of a positive association of ovulation induction with epithelial ovarian tumours, both borderline and malignant.

In the second category are mainly the risks of intravenous sedation and regional anaesthesia, and pelvic infection. In the third is the risk of needle damage to adjacent organs — bowel, bladder, uterus and vascular structures and of pelvic infection.

Obstetric complications seen with IVF-ET are mainly multiple births, low birth-weight and ectopic pregnancy. Selective foetal reduction is recommended if there are more than 4 foetuses. In some countries the law prohibits the transfer of more than 3 embryos.

Delivery by caesarean section is common. Low birth-weight babies comprise 32 per cent of births, mainly because of multiple pregnancy. Major congenital abnormalities occur in 2-3 per cent of the children which is the same as in the general population. The use of cryopreserved gametes or embryos does not increase the risk of congenital abnormalities and developmental milestones are similar in all groups.

### *Cryopreservation*

Cryopreservation of semen has been in use for over a century. Multiple follicle stimulation techniques provide oocytes or embryos in excess of the number required for fresh transfer. Embryo Cryopreservation is now an accepted method for these as 60-80 per cent of embryos survive freezing. Pregnancy rates are improved by up to 10 per cent. No adverse effects have been seen in babies born by this technique. The procedure involves cooling of embryos in the pronucleate or early cleavage state to very low temperatures in the presence of cryoprotectants, e.g. 12-propanediol, glycerol or dimethyl sulfoxide (DMSO) with sucrose which minimises damage to the embryos. They are then stored in liquid nitrogen till required. Over half the embryos survive the thawing process. Oocyte preservation has not been successful.

### *Oocyte Donation*

Oocyte donation has also emerged as a treatment modality in cases of premature ovarian failure or

resistant ovary syndrome, surgical castration, following chemo- or radiotherapy, ovarian dysgenesis, in women with hereditary genetic disease and with abnormal oocytes during IVF treatments.

Oocytes may be obtained from volunteers or known donors, spare oocytes from IVF programmes, from sterilisation patients prepared prior to operation or, in some countries, professional donors. In the future, cadaver donation or oocyte recovery from foetuses may be possible.

Pregnancy rates are higher in cycles using donated eggs (47% per cycle). However, there is also a higher risk of first trimester bleeding, pre-eclampsia and intrauterine growth restriction.

### *Embryo Donation*

Embryo donation may be indicated in some menopausal or perimenopausal women with a subfertile partner, in cases of recurrent IVF failure or in couples with genetic disease or chromosomal abnormality.

### *Surrogacy*

Surrogacy is an option for women without a uterus but with one or both ovaries functioning, as in cases with congenital absence of the uterus or those who have undergone hysterectomy for severe haemorrhage or ruptured uterus. Some patients with recurrent miscarriages or those with medical conditions which may make pregnancy life-threatening even though long-term health prospects are otherwise good, may also prefer to opt for surrogacy.

The host mother should be normal, healthy, not more than 38 years of age, with at least one child. Her husband or partner should be fully aware of the implications. Investigations of the host mother are kept to a minimum. Because of the risk of HIV infection, it is recommended that frozen sperm be used after waiting to cross the stipulated window period of 6 months. The procedure is relatively simple, cheap, with fewer complications than IVF and permits better bonding with the child although it is not genetically related. However, very few such cases are possible.

As was expected, the success of IVF has posed many ethical, social and legal problems which are being debated extensively in those countries where these procedures are carried out. Some of these issues were posed by Professor Jeffcoate in the fourth edition, well

before the success of Edwards and Steptoe. The answers to some of these issues are known, but many are still not fully resolved, particularly those related to the freezing and storage of donor ova or embryos, to the use of stored embryos, and to the disposal of those embryos not directly required in the management of infertility. At present, developments in this field are ahead of legal decisions. Public opinion is also changing; what was not acceptable a decade ago is now regarded as a normal event. It seems probable that fairly strict legislation will ultimately apply to certain infertility procedures and their performance in recognised institutions or centres.

### **Intrauterine Insemination (IUI)**

This involves the collection of semen by an emission occurring other than during coitus (usually by masturbation), and its transfer into the uterus. Intrauterine insemination is indicated when any of the following is present: ejaculatory failure which may be anatomical, e.g. hypospadias; secondary to spinal cord injury or other neurological problems; retrograde ejaculation as may occur in multiple sclerosis; impotence; male subfertility with oligo- or hypospermia, asthenozoospermia or teratozoospermia (though some of these patients may require ICSI (*see below*)); immunological factors like antisperm antibodies in the male or female; cervical mucus hostility or poor cervical mucus; disease or deformity of the cervix making it difficult for sperm to enter; in combination with superovulation in cases of unexplained infertility, mild to moderate endometriosis or ovarian dysfunction. In recent times, the processed semen of an HIV-positive partner has been used to inseminate an HIV-negative woman. Efficient techniques of cryopreservation of semen now make it possible for the husband's semen to be stored prior to treatment of cancer by surgery or radiotherapy, or orchidectomy for testicular cancer, and used for IUI after cure of the disease. It can be done in natural or stimulated cycles but better results are obtained with the latter. Standard protocols of clomiphene, clomiphene/FSH or gonadotrophin alone may be used. With the development of up to 4 mature follicles, there are better chances of implantation. Human chorionic gonadotrophin is administered when the leading follicle is 18 mm in size. If monitoring by ultrasound and hormonal profile is available, better pregnancy rates are obtained.

### Semen Preparation

Semen consists of seminal fluid with sperm and other cellular debris from the urogenital tract. Prostaglandins, enzymes and protease inhibitors present in the seminal fluid are detrimental to the fertilisation process in the fallopian tube or *in vitro*, as they provoke strong uterine contractions and impair sperm capacitation. The object of sperm preparation is to separate the sperm from the seminal fluid and provide a concentrated number of motile, capacitated sperm resuspended in a small volume of protein-supplemented medium.

The *swim-up technique* is commonly used and is suitable for samples with normal sperm count and motility. The semen is divided into 0.5 ml aliquots per centrifuge tube and diluted 2:1 with protein-supplemented medium to decrease viscosity and improve pellet formation. The tubes are centrifuged for 10 minutes at a speed not greater than 400 *g* to avoid damage to the sperm. The supernatant is removed and the pellets are overlaid with 0.5 ml of medium. They are incubated at 37°C for one hour. Motile sperms swim up into the supernatant which is collected from all the tubes and centrifuged at 300 *g* for 5 minutes. The final pellet is resuspended in 0.5 ml of medium.

Techniques using a *density gradient* are better for samples with a low sperm count and/or motility as they also significantly decrease bacterial contamination. Each millilitre of semen is placed on a column of silica particles or bovine albumin in centrifuge tubes and centrifuged for 20 minutes at 400 *g*. The sperm pellets are washed of the gradient matrix with media, combined and resuspended in 0.5 ml medium.

*Sperm wash* is used for severely low sperm counts and motility. In these cases the technique described above cannot provide adequate sperms. The undiluted semen is divided into 1ml aliquots, centrifuged at 300 *g* for 5 minutes, the supernatant removed and the pellet resuspended in 0.5 ml of fresh medium.

Insemination is carried out with a sterilised syringe and IUI cannula. Ordinary plastic cannulae may be toxic to spermatozoa. The washed sperm reconstituted in 0.5 ml of medium are *gently* injected into the uterus to avoid endometrial trauma which can cause cramping and bleeding resulting in poorer sperm survival. Pregnancy may occur at any sperm count but most occur when the count is 50000 to 1 million/ egg. Undiluted semen is never used because of the risk of transfer of infection. The technique has the advantage of being relatively

simple, cheap, effective and non-invasive. It can also be performed in non-IVF units. However, IVF units have the advantage that if hyperstimulation occurs, they may convert to IVF and freeze surplus embryos.

When IUI is used for retrograde ejaculation it is attended by many practical difficulties. It necessitates alkalinising the male urine, collecting a specimen after coitus, centrifuging it for spermatozoa and then using these for insemination after washing. Though successes have been reported, ICSI can be tried if the technique fails.

The overall success rate is about 18 to 20 per cent per cycle. Referral for IVF is recommended in case of failure to achieve a pregnancy in 4 to 6 cycles.

*IUI as Treatment of Male Factor Infertility:* Studies of the efficacy of IUI in the treatment of male factor infertility have been generally difficult to assess because of variations in inclusion criteria. Further, sperm function tests are not consistently used in these studies, nor is their use standardised. Considering these limitations, the benefits of IUI in male factor infertility have been accepted because IUI appears to result in higher pregnancy rates than natural intercourse or intracervical insemination (OR, 2.20; 95% CI, 1.43 to 3.39). However, the IUI pregnancy rates are generally lower in couples with male factor infertility than in couples with unexplained infertility (4.8% versus 11.6%).

Some couples with male factor infertility fail treatment with artificial insemination, and some have initial semen parameters that make insemination a suboptimal approach. In these couples, use of ART, especially with ICSI, may be superior treatment options. The efficacy of ICSI in ART allows almost all cases of male factor infertility to be highly treatable. ICSI only requires that viable sperm be present. Therefore, ICSI should be considered if the total motile sperm count is less than  $0.5 \times 10^6$  because the IUI success rates are extremely low with such sperm counts. Finally, ICSI should be recommended after a maximum of three to four IUI cycles have failed in a couple with male factor infertility.

### Donor Insemination (DI)

When the woman is normal but the man is infertile, when there are familial diseases or there is severe rhesus incompatibility (to produce a rhesus-negative foetus for the woman who has lost a series of babies as a result of

isoimmunisation despite advances in perinatal medicine including intrauterine transfusions, and whose husband is homozygous (rhesus positive), the instillation of *donated* semen of good quality will nearly always result in pregnancy - if the procedure is repeated sufficiently often.

With the advent of MESA, PESA and TESE for ICSI (*see below*) in male infertility, with the availability of pre-implantation genetic diagnosis (*see below*) in conditions such as haemophilia and cystic fibrosis (which allows transfer of normal embryos only) and with the decreasing incidence of rhesus isoimmunisation in developed countries, the demand for DI is decreasing except in developing countries, as the costs of these alternative procedures is much higher.

It is essential that adequate counselling of the couple concerned is done so that it can be ascertained that this method is acceptable and that they are likely to be suitable parents. The criteria are similar to those used for adoption but the upper age limit for the wife is usually 37 years. The couple should understand all the implications of DI and the risks of the pregnancy itself. Because of anonymity of the donor, genetic abnormalities cannot be looked for.

There is debate about the number of successful pregnancies which should be allowed per donor. Although at one time 20 seemed acceptable, the increasing use of DI suggests that 5 or 10 would be more appropriate. An exception could be considered when a second child by DI is requested by a couple.

The risk of transmission of AIDS by DI suggests that fresh semen would rarely be used. Tests for freedom from infection must be repeated after 6 months, before stored specimens can be used.

The general practice is to inseminate the woman for up to six or nine confirmed ovulatory cycles. The majority of successful inseminations occur within three ovular cycles and the success rate is certainly less in women with infertility problems which required treatment.

Overall, in a large clinic, there should be about a success rate of 60 per cent.

### Other ART Methods

Several ART methods have been developed over the years. Some of these include gamete intrafallopian transfer (GIFT); direct intraperitoneal insemination (DIPI); fallopian tube sperm perfusion (FSP) or

intrafallopian insemination (IFI); peritoneal oocyte sperm transfer (POST); zygote intrafallopian transfer (ZIFT); pronuclear stage tubal transfer (PROST); tubal embryo stage transfer (TEST); tubal embryo transfer (TET); embryo intrafallopian transfer (EIFT); surgical embryo transfer (SET); trans-myometrial embryo transfer (TM-ET); direct oocyte transfer (DOT); and intravaginal culture (IVC). Some have been discarded in favour of IUI, IVF or ICSI (*see below*).

Many of the terms are self-explanatory. DIPI and IUI give similar results; the latter is a simpler technique unless there is severe cervical stenosis. FSP has been replaced by IUI or IVF. POST is a good rescue procedure for IUI or FSP if hyperstimulation develops requiring cancellation of the cycle. ZIFT, PROST, TEST, TET and EIFT have been replaced by IVF since these procedures need general anaesthesia and laparoscopy. SET or TM-ET have a place in cases of severe cervical stenosis.

Certain steps and costs of laboratory procedure can be reduced in IVC by incubating the tubes containing the gametes in the vagina, but this is not acceptable to many women. With the development of transport IVF and portable incubators this is not required. In transport IVF, the complete clinical phase, i.e. initial oocyte recovery as well as subsequent follow-up after ET, is done at a facility near the patient's home. The oocyte is transported by the husband to the central IVF unit which takes care of the laboratory phase and ET. Thus the wife has to come to the central IVF unit only for ET.

Higher pregnancy rates have been reported with GIFT, ZIFT and TET as compared to uterine ET. However, this may be attributed to other variations in patient profile and technique and these methods are seldom used.

### *Intracytoplasmic Sperm Injection (ICSI)*

This technique has been used in cases of aspermia, azoospermia and in functional disorders of sperm. Partial zona dissection (PZD) and subzonal insemination (SUZI) have been used to improve sperm penetration, but with limited success. ICSI uses special equipment with 'holding' and 'injection' pipettes under an inverted microscope to stabilise the oocyte and inject the sperm. The technique is useful in cases of oligozoospermia, where conventional IVF has failed, or in azoospermia and aspermia. In this situation, a variety of methods have been used to obtain the sperm. These include the



following: rete testis aspiration (RETA), percutaneous epididymal sperm aspiration (PESA), testicular sperm aspiration (TESA), spermatocele aspiration (SPAS), microsurgical epididymal sperm aspiration (MESA), testicular sperm extraction (TESE).

Fresh or cryopreserved sperm can be used for further ICSI cycles. The commonly used procedures are MESA, PESA and TESA. PESA usually yields enough sperms for cryopreservation. Using a mixture of methods, a 90–94 per cent success in sperm retrieval is reported — fertilisation rates of 55 per cent per oocyte, regardless of sperm recovery method or diagnostic category, and pregnancy rates of 21–39 per cent per ET have been reported. Obstetric outcome is similar to that with other ARTs.

The recognised indications for treatment by ICSI include:

- Severe deficits in semen quality
- Obstructive azoospermia
- Nonobstructive azoospermia.

In addition, treatment by intracytoplasmic sperm injection should be considered for couples in whom a previous *in vitro* fertilisation treatment cycle has resulted in failed or very poor fertilisation.

**Surgical Sperm Recovery for ICSI:** Among the many surgical methods for sperm recovery, the most widely described are microsurgical epididymal sperm aspiration (MESA), percutaneous epididymal sperm aspiration (PESA), testicular sperm extraction (TESE), and percutaneous testicular sperm fine-needle aspiration (TESA, also called fine-needle aspiration, or FNA). The choice of surgical sperm recovery method depends on the underlying diagnosis, whether the goal of the procedure is diagnostic or therapeutic, and whether isolated sperm will be used immediately or will be cryopreserved.

TESA may be used to recover sperm in cases of post-testicular azoospermia (in which spermatogenesis is expected to be normal), with a successful sperm recovery in 96 per cent of patients. TESA is usually well tolerated by patients. It is typically performed with a 21-gauge needle with no anaesthesia or with a 19-gauge needle or biopsy gun using local anaesthesia. Fertilisation and implantation rates have been reported to be similar in a retrospective analysis comparing TESA with open biopsy using TESA. Alternatively, if the nature of the obstruction needs to be investigated by a full scrotal exploration, or

if attempted surgical correction of the obstruction will be performed at the time of sperm recovery, MESA may be the preferred procedure. MESA is performed with general or regional anaesthesia using a microsurgical approach. One advantage of MESA is that a very large number of spermatozoa are usually retrieved, so that cryopreservation and avoidance of repeat surgery may be possible. Fresh and frozen-thawed epididymal or testicular spermatozoa appear to have comparable fertilisation and ongoing pregnancy rates when used for ICSI.

Sperm retrieval using PESA is another option for the treatment of post-testicular azoospermia. PESA is performed using a 19-gauge needle with local or regional anaesthesia. A sperm recovery rate of greater than 80 per cent has been reported with 55 per cent fertilisation and 33 per cent ongoing pregnancy rates after ICSI. Although this procedure appears less invasive than some of its alternatives, it is performed blindly. Bleeding and epididymal injury are possible, and postsurgical fibrosis may result. In contrast, men with testicular azoospermia or gonadal failure require TESE, and possibly multiple biopsies, to retrieve sperm. However, the sperm recovery rate with TESE is only about 50 per cent, and clinical outcomes for ICSI after TESE among patients with testicular azoospermia are variable.

Lower fertilisation rates but comparable ongoing pregnancy rates have been reported for ICSI using testicular spermatozoa recovered from testicular azoospermia, compared with epididymal spermatozoa, post-testicular azoospermia. Sperm at all stages have been used to establish successful pregnancies using ICSI. However, the fertilisation and pregnancy rates associated with maturation-arrested spermatid are very low, and couples should be properly counselled regarding their prognosis and alternative options. Finally, cryopreservation of testicular tissues and of spermatozoa for use in subsequent ICSI treatment cycles has been reported.

#### *Preimplantation Genetic Diagnosis*

Prenatal diagnosis of genetic disorders has been further refined by the development of preimplantation genetic diagnosis (PIGD). A single cell is biopsied from the embryo at the 8-cell stage and enzymes, chromosomes or specific mutations evaluated by PCR and fluorescent *in situ* hybridisation (FISH). If the cell shows no

abnormality, the embryo is transferred to the mother. However, if any abnormality is identified, the embryo is discarded. Thus termination of pregnancy is avoided. Healthy babies have resulted from the use of such biopsied embryos.

## RESULTS OF TREATING INFERTILITY

No matter what treatment is applied or what advice is given to the infertile couple, conception will follow in a certain number of cases; this is inevitable by the laws of chance which govern conception. It is all too easy to claim a coincidence as a dramatic cure and this is the reason why so many treatments have their advocates. Scepticism in these matters is not popular but is justified by the findings in carefully documented series of cases. Of those women who consult a gynaecologist on account of *primary* infertility existing for two or more years, 50 per cent have at least one pregnancy within the next 6 years. In not less than half of the cases the occurrence of pregnancy can be shown to be unrelated to treatment. Indeed, 3-4 per cent of patients conceive before there is time to arrange for any investigation or treatment.

The occurrence of a pregnancy after treatment does not necessarily mean that the fertility of the marriage is raised. At least half the couples who produce one pregnancy after a phase of infertility find it impossible to repeat the performance.

When pregnancy occurs in an infertile woman, it may carry special risks. The chance of tubal implantation in those with tubal disease is five times greater than normal and that of abortion is doubled. The overall chance of obstetric complications is increased by one-third to a half. When, therefore, a pregnancy comes to a woman who has waited long, its management demands rigorous attention, for the loss of the child would be even more tragic than usual.

## DANGERS OF INVESTIGATING AND TREATING INFERTILITY

With proper safeguards, minor operative and other procedures involved in the investigation of infertility carry little risk to life, although the danger of an exacerbation of salpingo-oophoritis and the hazards of laparoscopy cannot be disregarded. The real menace of investigating and treating infertility is that they may concentrate the patient's attention on the problem, convert a complaint into an obsession, exacerbate the

already profound unhappiness, and even lead to the estrangement of the partners in marriage.

It is for these reasons that medical care should never be unduly protracted or complicated. Clinical examination, semen analysis, tubal patency tests, and biochemical assessment of ovulatory status, *if properly performed and interpreted*, will either be followed by pregnancy or reveal the causes of infertility in the majority of cases. In others, laparoscopy provides the answer. Treatment should be as rational as possible and should be abandoned if not successful within a reasonable period. There is an increasing tendency for women to be referred for a third or fourth opinion regarding infertility. There is always an optimum time to call a halt, but this depends on the particular couple, who are at liberty to desist at any stage but should also have access to more specialised units for another opinion.

If the couple have had a detailed and full assessment from a specialised unit then an honest and frank appraisal of their chances of conception and pregnancy should be given. A degree of optimism is healthy, but if any abnormality is found, the couple should be kept informed and the possibility of treating or overcoming the problem explained, including the reason for limiting the period of treatment if ineffective. *Either partner* will suffer loss of esteem if infertile and *each* could be expected to make adjustments in accepting the infertility of the other. In practice, an absolute situation rarely exists but in a few cases where it does, for example, azoospermia, the couple are entitled to the truth. This is important to their decision regarding further treatment by DI.

The fact that the woman has completely obstructed tubes no longer means there is no chance to conceive, for IVF-ET is a possibility, although it may not be available for that particular patient. The developments in the field of infertility over the last two decades have been dramatic and it is possible that in the next decade we will be able to explain and perhaps overcome some of the unexplained cases of infertility which now exist.

### Complications of ART

*Twins and Higher-order Multiple Gestation:* Multiple gestation, especially higher-order multiple gestation, is a serious complication of infertility treatment and has tremendous medical, psychological, social, and financial implications. In recent years, it has been reported that only 20 per cent of higher-order multiple gestations are

the result of spontaneous conceptions. The remaining 80 per cent are attributable to reproductive interventions. Of these multiple gestations, half are attributable to ART and half to the use of ovulation drugs in non-ART cycles.

**Ovarian Hyperstimulation Syndrome:** OHSS is a medical complication that is both completely iatrogenic and unique to the treatment of infertility. Although the pathophysiology of OHSS is not well understood, the signs and symptoms of this disease can be attributed to local and systemic increase in capillary permeability. These changes, in turn, result in the depletion of intravascular volume at the expense of third-space fluid accumulation.

OHSS has a varied spectrum of clinical presentation. An attempt to better understand this heterogeneity led to the development of a staging system for OHSS that would reflect symptom severity. This classification categorises patients into mild, moderate, and severe disease. In mild OHSS, patients often complain of mild abdominal distention and soreness, nausea, and vomiting. Ovarian enlargement can be 5 to 12 cm. Moderate disease is marked by the presence of abdominal ascites on ultrasound examination. Severe disease is diagnosed when there are clinical signs of tense ascites, hydrothorax, shortness of breath, haemoconcentration, hypercoagulability, or any complications of OHSS such as renal failure, thromboembolism, or acute respiratory distress syndrome (ARDS).

### Adoption

The adoption of a child is a matter on which individual outlooks differ. Some couples cannot tolerate the idea, others find it attractive. Only the latter make suitable foster parents. I have never encountered a couple who has regretted their decision to adopt a baby but it is possible that the venture may not always bring the happiness expected. Adoption as a solution to an infertility problem therefore deserves a cautious approach by those concerned. As in the case of DI, adoption should be presented as a possible option to consider. If not, the sad situation arises of the couple coming to terms with the concept of adoption only to find they are not acceptable due to their age or some other reason. They should be aware of the long waiting lists and limited availability of children, and in particular, babies for adoption.

If the husband and wife decide in favour of adoption they should do so by the legal machinery operating in their area. No doctor should take responsibility for the arrangements.

### Age and Decreased Ovarian Reserve

An association between the age of the woman and reduced fertility has been well documented, with the decline in fecundability beginning in the early 30s but accelerating during the late 30s and early 40s. Chronologic age is the strongest determinant of reproductive success in spontaneous and ART cycles because it is a predictor of ovarian reserve.

The fecundability of women undergoing donor insemination whose husbands are azoospermic provides insight into the effects of age on the fertility of the female alone. A French group that studied women enrolled in artificial insemination programs found that fertility rates begin to drop after 30 years of age. The pregnancy rate after 1 year of inseminations was 74 per cent in women aged 30 years and younger, 62 per cent in women aged 30 to 35 years, and 54 per cent in women older than 35 years of age.

The physiology of declining fertility in older women is better understood in light of data from oocyte donation programs. When embryos produced from oocytes retrieved from younger women are transferred into older women, the pregnancy rates among the older women approximate those of the younger women, and variations in pregnancy rates are directly dependent on the age of the donors, not that of the recipients. Several observations strongly support that it is the age of the oocyte, rather than the age of the endometrium, that accounts for the age-related decline in female fertility.

This oocyte-related decline in fertility is also known as decreased ovarian reserve. Absolute evidence of decreased ovarian reserve often can be ascertained only after ART treatment shows decreased ovarian responsiveness to COH. In ART, decreased ovarian reserve is reflected by an increased requirement for gonadotropins (FSH  $\pm$  LH), small numbers of ovarian follicles and oocytes, and low serum oestradiol levels during exogenous stimulation of folliculogenesis. These clinical outcomes probably reflect a decreased number of ovarian antral follicles as well as poor quality of granulosa cells and oocytes. Although age is the best predictor of ovarian reserve as reflected by ovarian

responsiveness to COH, there is a subset of women who demonstrate an ovarian reserve that is prematurely diminished based on their chronologic age. Similarly, there are women who respond well to COH and achieve pregnancies despite their advanced age. Therefore, tremendous efforts have been expended to identify an ovarian reserve test that can be used to counsel patients and to guide their management.

Ovarian reserve screening tests that have been proposed include serum day 3 FSH, clomiphene citrate challenge test (CCCT), serum inhibin B, and transvaginal ultrasound to assess antral follicle number or ovarian size. Measurement of day 3 FSH is based on evidence that small increases in basal serum FSH levels correlate with the decreased fecundability seen among women in their late 30s. Counting of antral follicles is a good method and if a woman has less than four antral follicles they usually are poor responders.

Recently, serum inhibin B has also been proposed as a potential screening test for ovarian reserve. Inhibin B is produced by ovarian granulosa cells predominantly during the follicular phase of the menstrual cycle. Inhibin B suppresses the production of FSH by the pituitary gland. The normal rise in circulating levels of FSH associated with menopause is thought to be secondary to the decrease in inhibin B production accompanying the age-related depletion of functional ovarian follicles. In fact, in the CCCT, the main mechanism by which FSH is normally suppressed is via inhibin B production by granulosa cells. Women with decreased ovarian reserve have a lower rise in the day 10 serum inhibin B levels in response to the CCCT. In addition, women who have clinical evidence of diminished ovarian reserve and normal day 3 FSH levels have been found to have decreased day 3 inhibin B levels. This observation suggests that a decrease in day 3 serum inhibin B levels may precede detectable changes in day 3 FSH levels. However, basal inhibin B levels do not provide additional age-independent prognostic value for

predicting pregnancy outcomes after ART. One possible reason for this is that levels of inhibin B may reflect granulosa cell function and thereby only forecast ovarian response in ART. Although granulosa cell competence is certainly associated with oocyte quality, clinical application of serum inhibin B testing will also depend on whether levels are predictive of normal meiotic division of the oocyte because foetal karyotype is an important determinant of pregnancy outcome.

*Conclusion:* Very few couples have absolute infertility, which can result from congenital or acquired irreversible loss of functional gametes in either partner or the absence of a uterus in the female. These specific couples should be counselled regarding their options of adoption, the use of donor gametes, or surrogacy. Rather, most couples who have difficulty conceiving have subfertility. According to this fundamental concept, most couples could conceive spontaneously in time, but because of known or unidentifiable causes, their spontaneous fecundity rate is so low that medical management is warranted. Another reason to seek medical attention, particularly among older women, is that as time passes during unsuccessful spontaneous attempts, fecundability will be further compromised by increasing age and concomitantly decreasing ovarian reserve. Although identification of apparent causes of subfertility (such as anovulation or oligospermia) allows treatment to be targeted, effective empiric treatments greatly increase the chance of a pregnancy even when no distinct cause is identified. Overall, these treatments aim at increasing the probability of conception and implantation by optimising gamete (sperm and oocyte) and uterine factors. However, it is important to realise that the age of a woman is a factor to be considered and there should not be any delay in offering any form of treatment which is suitable for the couple. Assisted reproductive technology has changed the methodology of treatment and seems to be an effective method of infertility treatment.

# CHAPTER 47

## Instruments and Gynaecological Procedures

Instruments	731
Gynaecological Procedures	738

### INSTRUMENTS

Instruments in Gynaecological Surgery are both general and specific to gynaecologic surgery. Many new modification and variations in the instruments have come up but a surgeon should insist on a broad range of high quality functioning equipments that do not continually irritate by failing to work, whether it is a simple pair of scissors or the most sophisticated minimal access equipment.

In virtually all modern operating theatre, instruments and drapes are prepacked and sterilised in 'sets' for individual or generic procedures in a central sterile supply department. This has major advantage in terms of high standards of sterilisation over selecting instruments for a specific procedure and sterilising them immediately prior to an operation.

A wide range of prepacked and sterile disposable instruments of amazing complexity have been introduced in recent times, including much of the equipment used in minimal access surgery.

Besides the 'set' and presterilised instruments, from time to time an immediate sterilising facility is required so that in many operating theatres on the spot sterilisation is available for a number of specialised pieces of equipment.

The instruments can generally be divided into:

- a. General operating set
- b. Minor procedure set
- c. Special instruments and laparoscopy instruments

The general operating set commonly consists of:

1. Sponge holding forceps
2. Towel clips
3. Bard Parker knife handle
4. Hane's toothed dissecting forceps
5. Non toothed dissecting forceps
6. Scissors Mayos dissecting
7. Scissors straight
8. Lloyd Davis needle holder
9. A set of Grey Turner artery forceps straight and curved
10. A set of Allis forceps
11. Kocher's clamps – straight and curved

12. Vulsellum
13. Retractors — Doyens and Langenhan's
14. Babcock's forceps
15. Needle holders

Minor procedure set consists of:

- Sponge holder
- Sims vaginal speculum
- Anterior vaginal mall retractor
- Vulsellum
- Uterine sound "Simpsons"
- Bladder sound
- 1 set cervical dilators
- Blunt and sharp curette
- Needle holder
- Artery forceps
- Scissors 6"

A minor vaginal set for dilatation and curettage and for suction evacuation is shown in Fig. 47.1.

### Some of the Instruments Mentioned Warrant Special Comments

#### Scissors

Often marketed as Mayo scissors (Fig 47.2). They are heavy but have a sureness about them, which allows accurate gentle dissection, particularly of the 'separate and cut' type. The ends of the scissors are relatively blunt and will do little damage when separating tissue, while

the blades are powerful enough to cut when coupled with long levers of the handles. This latter characteristic is especially important in cancer work when operating on tissues previously treated with radiotherapy.

A lighter scissor with the same qualities e.g. Monaghan's dissecting scissors is also useful.

#### Artery Forceps (Fig 47.3)

The forceps included in the set are almost all straight. Meig's right angle forceps are of great value in dealing with vessels deep in the pelvis. They are long and allow suture to be placed around either the points or the heel of the forceps.

#### Tissue Clamps

On many occasions in gynaecological surgery, it is necessary to clamp discrete blocks of tissues firmly and then suture the block to occlude the vessels contained within it. It is important that these clamps are strong, that the jaws oppose accurately and that tissue does not slide over from between the jaws. Many different varieties have been designed but the Kocher's clamps are the most widely used. As a general principle, the designs with longitudinal ridges have an advantage over those with transverse. In addition, a simple tooth interdigitating with a double tooth at the tips of the jaws assist correct apposition. The clamps can be straight or angled (Fig 47.4).



Fig. 47.1: D&C and MTP set



Fig. 47.2: Mayo scissors

- a. Length of uterus and direction of uterus
- b. To diagnose and differentiate a polyp lying in Cervix.
- c. Locating misplaced IUD
- d. Correction of mobile retroversion of uterus.

*Blunt and Sharp Curette*

Designed by Blake, one end of instrument is blunt, 2nd end is sharp. It is used in D&C, D&E, infertility and DUB (Fig 47.6).

*Sims Double Bladed Posterior Vaginal Speculum (Fig 47.7)*

Designed by—Morion Sims, the blades are of unequal breadth. It may be single bladed also.

It is used to visualise the cervix and Inspect the lesion of cervix and anterior vaginal wall. It is also used for practically all vaginal operations, e.g. D&C, D&E, vaginal hysterectomies etc.

*Cusco's Bivalve Self-retaining Vaginal Speculum (Fig 47.8)*

The valves are to retract the anterior and posterior vaginal wall to have a good look at the cervix. It is used to:

- a. Visualise the cervix and vaginal fornices



Fig. 47.3: Artery forceps



Fig. 47.4: Tissue clamps

*Uterine Sound (Fig 47.5)*

Designed by Simpson they are 12" long and marked in inches. They have blunt bounded tip. The Uterine end is curved and angulated. They are used to determine



Fig. 47.5: Uterine sound



Fig. 47.6: Blunt and sharp curettage

- b. Collect vaginal pool materials and scrapings for cytologic study
- c. Perform minor operations on the cervix



Fig. 47.7: Sim's speculum



Fig. 47.8: Cusco's speculum



Fig. 47.9: Anterior vaginal wall retractor

*Anterior Vaginal Wall Retractor (Fig 47.9)*

This instrument has loop shaped ends with transverse serrations on the loops. The loops are set at angle to the shaft. It is used along with Sims Speculum to retract the sagging vaginal wall to have a good exposure of the cervix.

*Cervical Dilators (Fig 47.10)*

Many types are available e.g. Hegar's, Das's, Hawkin-Ambler's etc . They are used to dilate the cervix before D&C, D&E, pyometra, Haematometra, Intracavitary RXT etc.

*Vulsellum (Fig 47.11)*

Designed by Teals. This instrument is 8" long and is usually curved. It has sharp teeth at the end, which interlock and give a firm grip. If only two × one interlock is present, it is known as tenaculum. It is used:

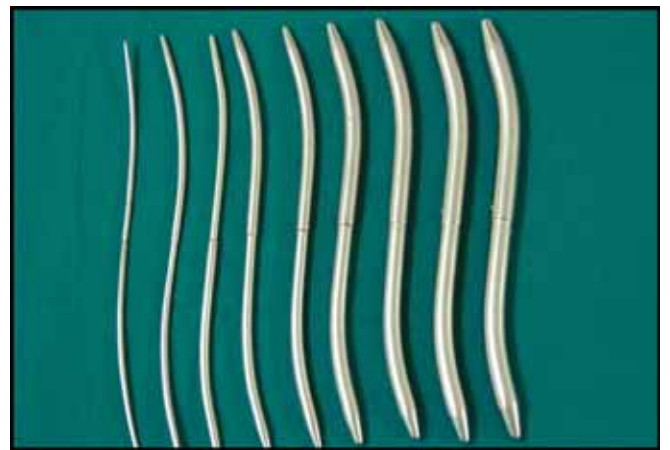


Fig. 47.10: Dilator set



Fig. 47.11: Vulsellum



- a. To grasp the anterior/post lip of CR. To make the cervix steady during cervical operations.
- b. To remove polyps.
- c. To hold the fundus during abdominal hysterectomy.

### Specific Instruments used only for Gynaecological Operations

The use of general instruments (Fig 47.12) is known to all, so only, a special mention for the specific instruments used for a particular gynaecologic operation are being given.

1. *Boney's Myomectomy Clamp* (Fig 47.13): Used to control haemorrhage during myomectomy. A piece of rubber tubing is fixed over each blade. The clamp grasps the body of uterus just above internal OS of the cervix and includes uterine vessels and both round ligaments.
2. *Myoma Screw* (*Doyens*) (Fig 47.14): Used to fix the myoma after the capsule is cut opened to give traction while myoma is enucleated out of its bed. Also to give traction in a big uterus requiring hysterectomy.



Fig. 47.12: Abdominal instrument set



Fig. 47.13: Myomectomy clamp

3. *Malleable Probes* (Fig 47.15): Used in tubal recanalizations.
4. *Rubin's Insufflation* (Fig 47.16) canula for tubal testing. With better diagnostic technique available, not much in use now.
5. *Karman's Syringe* (Fig 47.17A) or menstrual regulation syringe, which has a capacity of 50 ml. usually used for endometrial aspiration especially when patient has missed her periods.
6. *Leech Wilkinson Canula* (Fig 47.16): Used for chromopertubation during laparoscopy and hysterosalpingography.



Fig. 47.14: Myoma screw



Fig. 47.15: Malleable probes



Fig. 47.16: Tubal patency testing cannualas

7. *Vaginal Dilators* (Fig 47.17B): They are made of glass, vulcanite, plastic or steel. They are tubular in shape with one end rounded and a depression on the other end to accommodate the urethra. Available in 6 sizes. They are used to dilate the vagina in cases of (a) Vaginismus, (b) Vaginal atresia due to burn/injuries/operations (c) Artificial Vagina in cases of congenital absence
8. *Endometrial Biopsy Curette* (Fig 47.18): The name implies its use. There are slender tubular blunt ended instruments slightly curved at the tips. There is a notch with a cutting edge near the tip. Used to take endometrial biopsy. Endometrial sample is taken from six different areas of uterus.

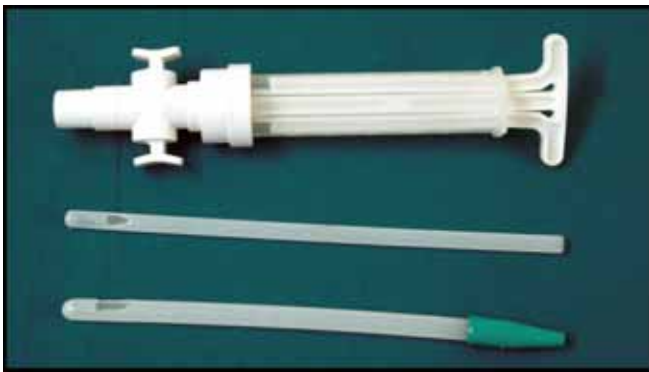


Fig. 47.17A: Karman syringe



Fig. 47.17B: Vaginal dilator



Fig. 47.18: Endometrial biopsy curette

9. *Ovum holding forceps* (Fig 47.19): Designed by Haywood Smiths used during medical terminations of pregnancies and other abortions to remove retained products of conception or placenta. The blades of the instrument have spoon shaped blunt fenestrated ends. Anything held in the blades is firmly caught but not nipped at its base. It has no catch.
10. *Ayer's spatula* (Fig 47.20) for taking cervical samples for pap smear in suspected cases of cervical cancers.
11. *Cervical punch biopsy forceps* (Fig 47.21) for taking cervical biopsy from any suspicious area on the cervix in cases of cervical malignancies. Designed by Gelhorns. This instrument is 22.5 cm. long and has punch shaped ends inside the cup. On one fair is a tiny pin to hold the specimen punched out.
12. *Hysteroscope, laparoscope* and other endoscopy instruments are now being widely used in gynaecologic practice. The era of minimal invasive surgery requires to surgeon to have special training in handling and using these instruments.
13. *Microsurgery instruments* (Fig 47.23) also require special training and care.

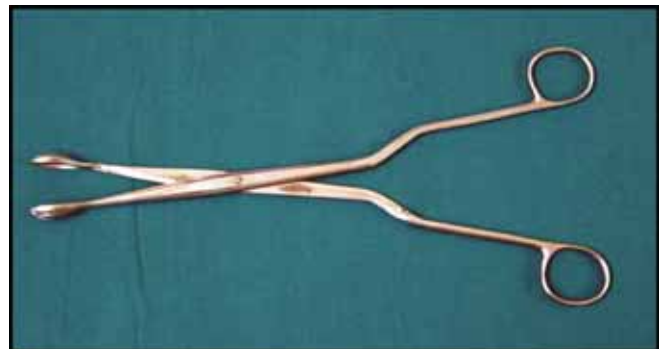


Fig. 47.19: Ovum forceps



Fig. 47.20: Ayer's spatula

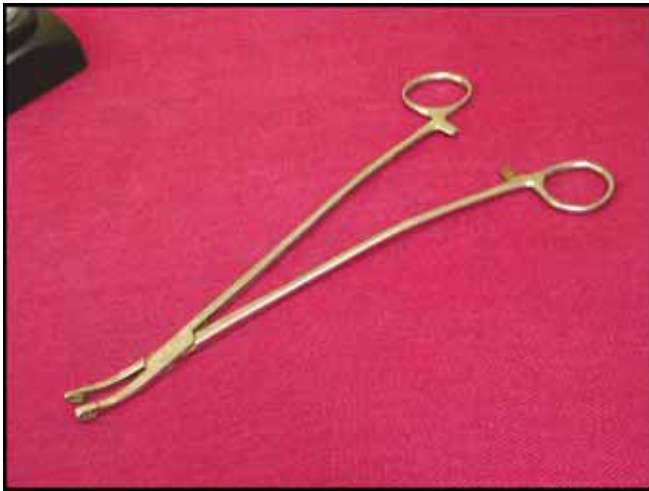


Fig. 47.21: Cervical punch biopsy forceps



Fig. 47.23: Microsurgery instruments

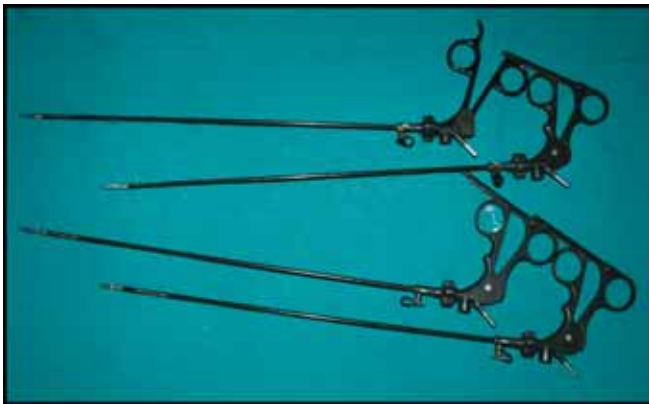


Fig. 47.22: Laparoscopy hand instruments



Fig. 47.24: Absorbable synthetic

### Suture Materials

They may be organic, synthetic or metallic from a practical point of view. They may be classified as absorbable and non-absorbable.

*Absorbable Sutures* (Fig. 47.24)

- Organic - Catgut
- Synthetic - Polyglycolic Acid and Polyglactin

*Non-absorbable Sutures* (Fig. 47.25)

Braided/Multifilament - Silks, Cotton 2 linen, mersilene

Monofilament - Nylon, Dacron, Teflon

The suture material being used varies with the surgeon and availability, as with the time it takes to get



Fig. 47.25: Non-absorbable sutures

dissolved in the human body and the tensile strength is languid.

To conclude, instruments should be handled with care. Proper sterilisation has to be used. Many newer and better modifications are coming up as evolution is the way of life but basic principles remain the same.

## GYNAECOLOGICAL PROCEDURES

Gynaecology today has evolved from the blind per vaginal examination done in the Victorian era (Fig. 47.25) to modern gadgetry and equipments as our aids to a look into the pelvis. Every gynaecological examination should be systematic and start with a per speculum and a per vaginum examination followed by colposcopy, ultrasonography and then if required invasive procedures like endometrial or cervical biopsy, dilatation and curettage, hysteroscopy, laparoscopy and so on.

A gynaecological examination should proceed in sequence:

1. Vaginal and per rectum examination
2. Speculum examination
3. Taking a vaginal and cervical smear
4. Taking endometrial biopsy and cytology
5. D & C
6. Colposcopy
7. Transvaginal ultrasound
8. Hysteroscopy
9. Laparoscopy

### Speculum Examination

Speculum examination is done to view structure of vulva and vagina including the cervix and to obtain microbial and biopsy material for laboratory examination. This procedure can be done in OPD in lithotomy position with no anaesthesia required.

#### Procedure

- Clean the external genitalia with 1 per cent cetrimide using sponge holding forceps.
- Introduce a lubricated speculum.
- Good light is necessary to visualise properly.

#### Instruments Used

- Speculum
  - Sims speculum
  - Cusco self retaining speculum
  - Fergussons speculum
- Rampleys sponge holding forceps

#### Other Instruments that may be Used

- Jaylis vaginal retractor
- Richter vulva retractor
- Teales vulsellum forceps
- Sims anterior vaginal wall retractor

### Vaginal Examination

Patient in lithotomy position. After separating the labia with thumb and index finger of left hand, two fingers usually index and forefinger of right hand is gradually introduced beyond introitus upto fornices.

Uterus positioning and direction of cervix can be noted.

Consistency of cervix is looked at. It is soft in pregnancy and firm in non-pregnant state. Clinician should observe whether movement of cervix causes pain. This is seen in ectopic pregnancy or PID.

Now left hand is placed over abdomen and uterus can be bimanually palpated for position, size, shape, mobility, tenderness and presence of any uterine pathology.

Swellings which can be identified are ovarian cyst, neoplasms, paraovarian cysts, tubo-ovarian masses and chronic ectopic pregnancy. Then palpate posterior fornix which enables the palpation of contents of pouch of Douglas. Common swelling felt can be loaded rectum, uterine fibroid, ovarian neoplasms, chocolate cyst of ovary and endometriotic nodules.

### Dilatation of Cervix and Curettage

D & C is a gynaecological procedure which has two components

- To enlarge cervical canal
- Removal of endocervical or endometrial tissue for histologic study by scraping

*Anaesthesia:* Local/Epidural/General

*Position:* Lithotomy

*Procedure:* Patient is explained the procedure

- Lithotomy position
- Empty bladder
- Clean the vulva, vagina and perineum
- Drapping with sterile towels
- Sims speculum is introduced with anterior vaginal wall retractor
- Vulsellum for holding anterior lip of cervix
- Pass uterine sound to determine size and direction of uterine cavity

- Pass dilators steadily and gently
- Cervix should be dilated enough to admit the curette easily
- After dilatation sharp curette is passed in axis of cervico-uterine canal till it touches the fundus
- With steady pressure scrape down in all direction in a systematic way
- A grating sensation is felt by curette when endometrium is satisfactorily removed
- Collect the endometrium in saline or citrate solution
- Gently massage uterus between 2 hands to remove all blood

#### *Instruments Used*

- Kidney dish
- Sponge forceps
- Sterile drapes
- Urinary catheter
- Antiseptic solution
- Sterile pads
- Sims speculum
- Hegars dilator
- Uterine curette sharp and blunt
- Simpson's uterine sound
- Anterior vaginal wall retractor
- Vulsellum
- Sharmans biopsy curette

#### *C/I*

- Pregnancy
- Cervical and vaginal infection

#### *Complications*

- Perforation of uterus
- Cervical tear
- Infection
- Asherman's syndrome

### **Endometrial Biopsy**

Endometrial biopsy is done after giving cervical block with a sedative.

A pervaginal examination is done to determine size and direction of uterus.

A uterine sound is passed to confirm the length and direction. A small dilator may be required prior to passing the curette.

Specimen of cervical canal or endometrium is obtained by using endometrial biopsy curette.

It is done for obtaining endometrial biopsy in cases of tuberculosis to confirm malignancy and in cases of infertility to confirm act of ovulation.

### **Cervical Punch Biopsy**

Cervical Biopsy is taken in cases where there is a suspicious cervical lesion for malignancy. May be taken as a punch biopsy or by knife as a wedge biopsy or a cone biopsy.

#### *Steps*

Patient is put in lithotomy position. A mild general anaesthesia or paracervical block is used.

Biopsy is taken by the punch biopsy forceps at the junction of normal and abnormal cervical tissue. This may also be done under colposcopy guidance. Haemostasis is obtained by canterising the raw area or by applying a stitch with 2 'O' absorbable suture material. Patient is given instructions for perineal hygiene and to avoid intercourse. The tissue obtained is sent for histopathological examination.

### **Hysteroscopy**

Hysteroscopy is an endoscopic procedure of visualising the inside of a uterus by direct method.

#### *Indications*

1. Evaluating the endocervical canal for any neoplastic extension
2. Congenital malformation of uterus
3. Abnormal bleeding. It is easier to identify lesions like polyps, endometrial hyperplasia, vascular anomalies, endometrial carcinoma by hysteroscopy.
4. For locally lost intrauterine devices.
5. Pregnancy related problems like retained molar tissue can be confirmed
6. To see uterine synechiae and for diagnosis of Asherman's syndrome

#### *Technique*

Position – lithotomy position

Position of uterus is confirmed by bimanual examination. Speculum is introduced and cervix exposed. Clean cervix with saline and betadine.

Hold anterior tip of cervix with vulsellum, confirm axis of uterus with a uterine sound. Cervix is dilated up to 4 mm.

Hysteroscopy connected with distension medium is advanced in the cavity under direct vision. The ostia, uterine walls and cavity is inspected and findings are documented.

#### *Complications*

1. Infection
2. Perforation – To avoid introduce the telescope under direct vision.
3. Bleeding diathesis
4. Allergic reactions to the distension media.
5. Gas embolism can be reduced by using proper insufflating equipment.

#### **Colposcopy**

Colposcopy is used in obtaining directed biopsy from suspicious areas on cervix in women with positive pap smears.

Suspicious areas are seen as aceto-white areas, a mosaic pattern, punctation with or without presence of abnormal vessels.

#### *Technique*

Patient is placed in lithotomy position, cervix is exposed with a speculum and colposcope is introduced, focusing on external os at a distance of about 20 cm.

The SQ junction is inspected before and after applying 3-5 per cent aqueous acetic acid solution. Acetic acid precipitates proteins and abnormal epithelium appears white.

For a more clearer assessment of vascular architecture a green light filter can be used. After this, cervix is painted with Schiller's iodine which differentiates darker glycogen laden cells from paler glycogen free cells. Neoplastic tissue is devoid of glycogen and it, therefore does not take up iodine stain. The non-stained areas are then biopsed.

#### *Indications*

1. Abnormal pap smear cytology
2. To obtain a directed biopsy
3. To locate abnormal areas
4. For conservative therapy under colposcopic guidance
5. Follow-up cases.

Colposcopy helps to reduce false-positive reports. Presently exfoliative cytology and colposcopy are considered complimentary to each other and have contributed immensely in reducing incidence of invasive cancers of cervix.

*Laparoscopy* (Fig. 47.22) is discussed in detail in chapter 49.

# CHAPTER 48

## Ultrasonography in Gynaecology

Ultrasonography	741	Vagina	756
Normal Female Pelvis	741	Ovarian Sonography	756
Ultrasound of the Uterus	744	Ovarian Neoplasms	763
Diseases of the Myometrium	746	Gestational Trophoblastic Disorders	765
Diseases of the Endometrium	747	Summary	766
Diseases of the Uterine Cavity	747	Conclusion	766
Diseases of the Cervix	756		

### ULTRASONOGRAPHY

High-resolution transvaginal sonography (TVS) has been widely available since mid 1980 and has gained acceptance as an integral part of gynaecologic and easily obstetric sonographic examinations. In many ultrasound laboratories, the standard examination of female pelvis consist of transvesical-transabdominal (TAS) combined with TVS and in some cases, transvaginal colour flow Doppler (TVCFD) (Figs 48.1 and 48.2).

Patient need not be fasting unless an upper abdomen scan is also asked for. TAS is performed first which provides a wider field for view and overview of pelvic organs. For a TVS, patient is asked to void immediately before examination. The transvaginal approach bypasses attenuating tissue and allows a high frequency probe to be placed close to 'target organs'. Scanning is performed with patient supine, thighs abducted and knees flexed. Probe is covered with a condom or sheath containing small amount of gel. Probe is inserted gently with slight push towards rectum. Four types of probe movements are required (i) pushing and pulling, (ii) Rotation, (iii) Rocking or upwards and downwards, (iv) Side to side or 'Panning' (Figs 48.3A to C and 48.4A to D). Today finger tip and finger cap probes are also available (Fig. 48.5A and B).

TVS probe may be disinfected by cidex.

### NORMAL FEMALE PELVIS

Female pelvis consists of true and false pelvis. Female genital organs lie within true pelvis (Fig. 48.6).



Fig. 48.1: TVS and TAS probe

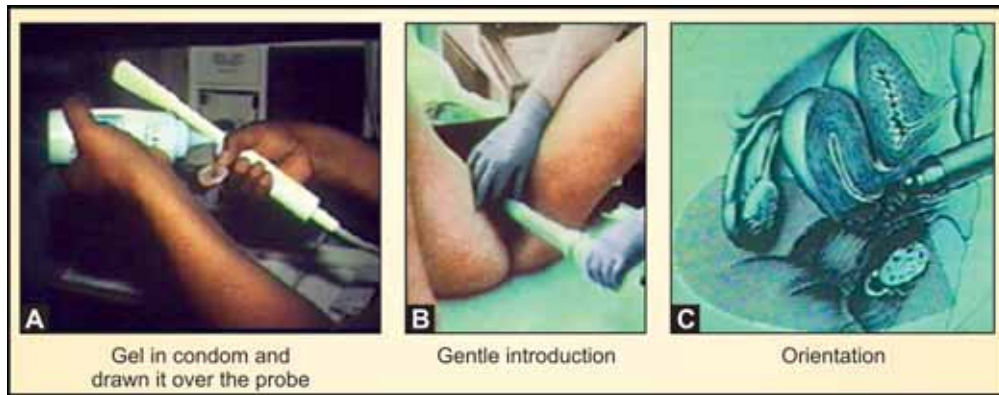


Fig. 48.2: USG machine

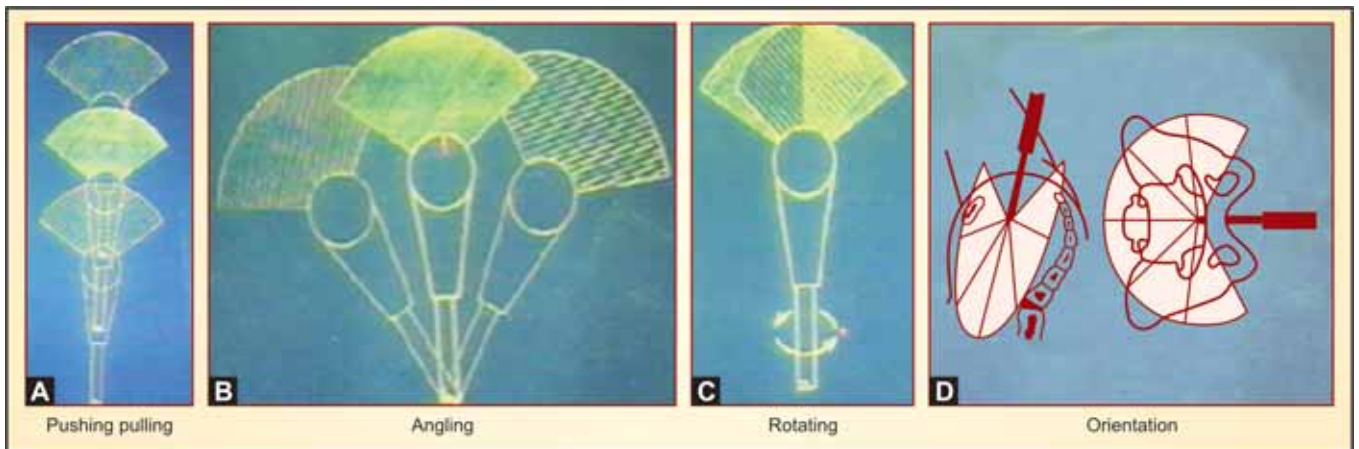
### Uterus

It is a pear like organ between urinary bladder anteriorly and rectosigmoid posteriorly. It consists of two major parts : the body or corpus and the cervix. Isthmus separates the body and cervix. Fundus of the uterus is the superior portion of the uterus between the insertion of the tubes.

The ratio of the length of body and cervix varies with age. Before menarche, the corpus is approximately one half the length of cervix; in nulliparous women, the corpus and cervix are of approximately equal length, and in multiparous women, the corpus is about twice the length of the cervix.

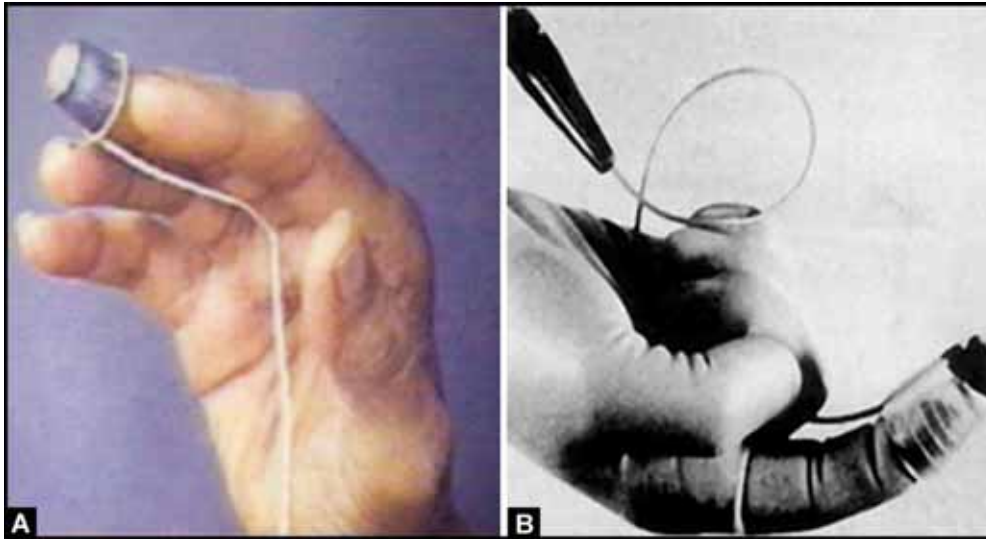


Figs 48.3A to C: TVS procedure



Figs 48.4A to D: TVS procedure—probe movements





Figs 48.5A and B: TVS finger cap probe

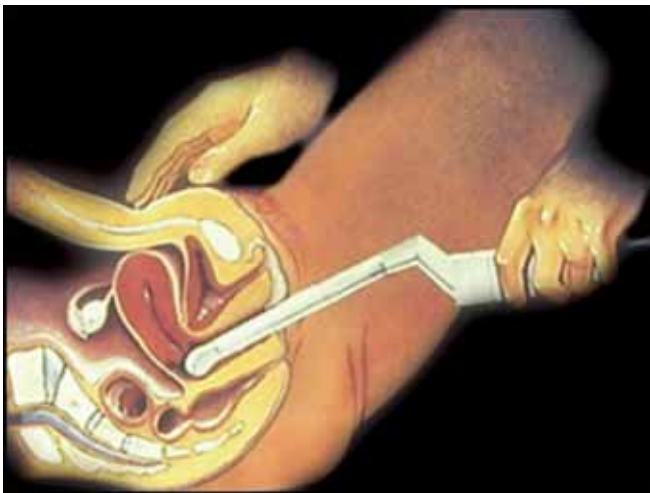


Fig. 48.6: Female Pelvis with TVS Probe

Uterus measures about  $8 \times 4 \times 4$  cm in childbearing age, which increases by about 1 cm in multiparous women. After menopause, uterus atrophies.

Uterus consists of (i) *Myometrium*: It is homogenous in echotexture with smooth margins. (ii) *Endometrium*: It is seen as a hyperechoic band in the centre of the uterus. The total thickness represents the anterior and posterior opposed layers. Normal endometrial thickness and appearance varies with phase of menstrual cycle. Endometrial fluid when present should not be included in the measurement (Fig. 48.7).



Fig. 48.7: Uterus and Endometrium

### Ovaries

Ovaries are ellipsoidal; position is variable especially in multiparous women. In nulliparous female, ovaries are situated in the ovaries fossa (also known as fossa of Waldeyer). The ovarian fossa is situated on the lateral pelvic wall and is bounded anteriorly by the obliterated umbilical artery, ureter and internal iliac artery posteriorly and the external iliac vein superiorly (Fig. 48.8).

Ovaries in girls younger than 2 years of age are typically less than 1 ml in volume. After menarche, ovaries generally measure  $30 \times 20 \times 20$  mm (Fig. 48.8).

### Folliculogenesis

In proliferative phase of menstrual cycle, multiple small follicles of 10 mm in diameter are seen (Fig. 48.9). A



Fig. 48.8: Normal ovary by ultrasound

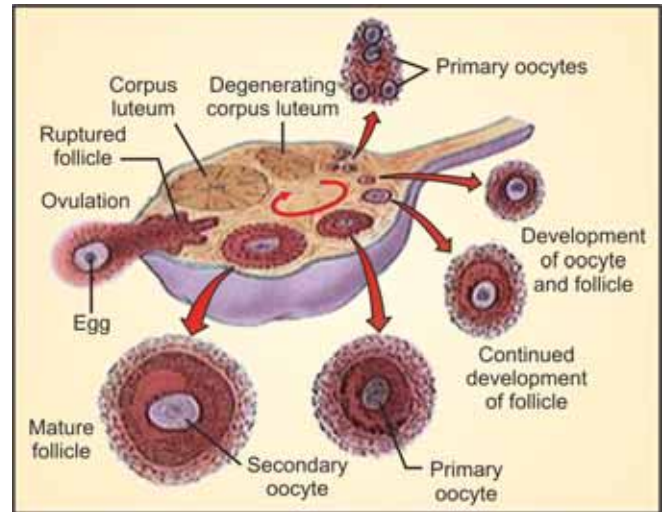
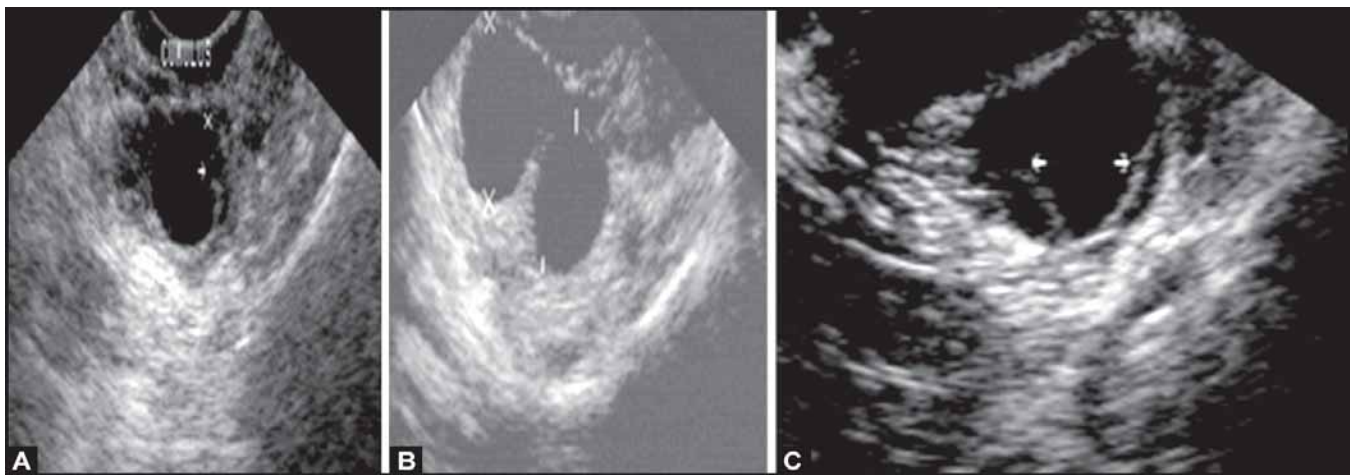


Fig. 48.9: Folliculogenesis



A Cumulus

B Size

C In folding

Figs 48.10A to C: Periovulatory follicle features

dominant follicle develops in midcycle which measures upto 20 mm in diameter. The follicle shows a cumulus and infolding just before ovulation (Figs 48.10A to C). After ovulation corpus luteum develops.

### Fallopian Tubes

These originate from the lateral uterine angles towards their respective ovaries. These measure approximately 7-12 cm in length and are a few mm wide. Normal fallopian tubes are normally not visualised by ultrasound unless abnormal or surrounded by fluid (Fig. 48.12).

### Pouch of Douglas

Also known as cul-de-sac or recto-uterine pouch. Small amount of fluid may be physiological within the sac (Fig. 48.13).

### ULTRASOUND OF THE UTERUS

Sonographic evaluation of uterus comprises checking for:

1. Size
2. Shape
3. Position
4. Surface



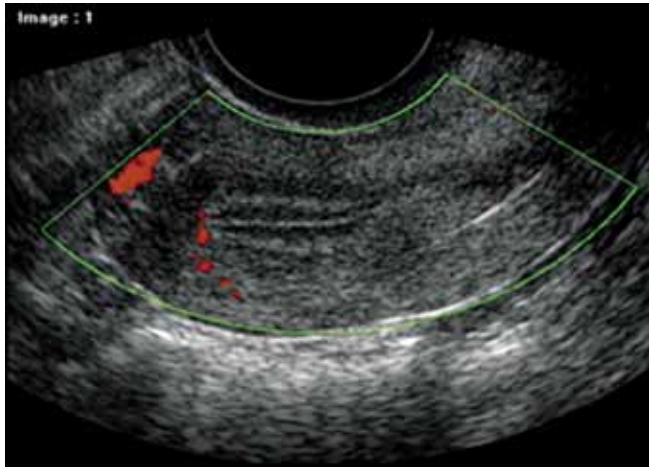


Fig. 48.15: Normal size uterus



Fig. 48.16: Menopausal uterus

### Uterine Shape

Abnormal uterine shape may be seen with congenital malformations which result from defects in lateral fusion of müllerian ducts or subsequent incomplete septal resorption. These include :

- Uterus Didelphus*: Two uteri, two cervix and may be a septated vagina. (Figs 48.17A and B)
- Bicornis Bicollis*: Two uteri and two cervix and two vagina. (Fig. 48.18)
- Bicornuate (Unicollis) Uterus*: Two uteri with partially fused lower segment. (Fig. 48.19)
- Septate Uterus*: Thick or thin fibrous septa divides the myometrial component. (Fig. 48.20)
- Arcuate Uterus*: Fundal dimpling is seen. (Fig. 48.21)
- Unicornis uterus with rudimentary horn. (Fig. 48.21A)
- T-shapes uterus (Fig. 48.21B)

### DISEASES OF THE MYOMETRIUM

#### Benign conditions:

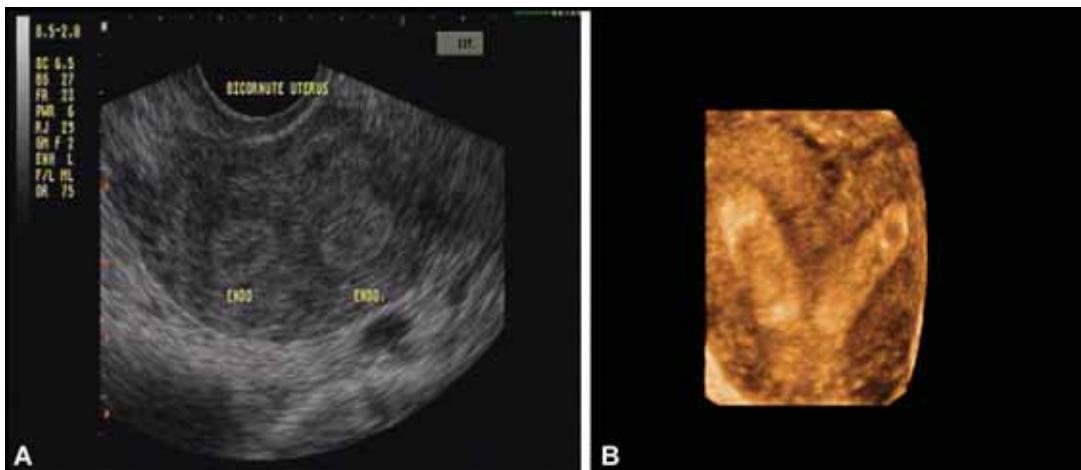
- Adenomyosis (Figs 48.22 to 48.24)
- Myometritis
- Myometrial calcification

#### Benign tumours :

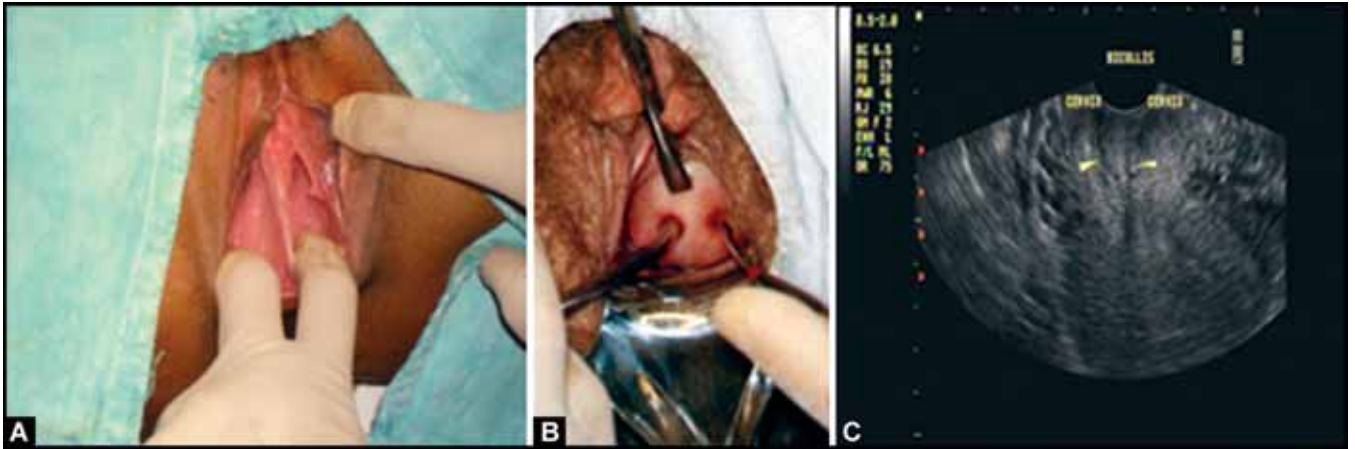
- Leiomyoma (Figs 48.25 to 48.27)
- Arteriovenous malformation (Fig. 48.28)

#### Malignant Tumour :

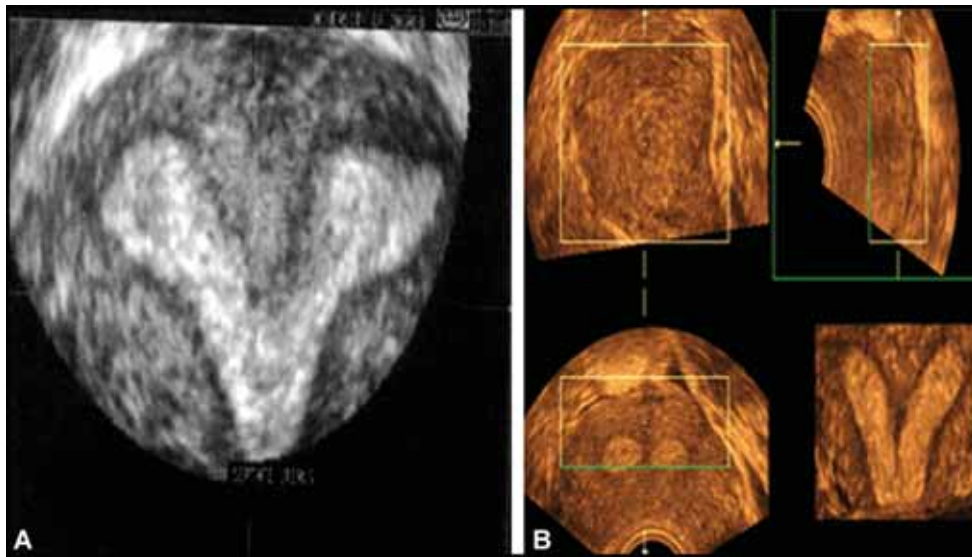
- Sarcomatous change in leiomyoma (Fig. 48.29)



Figs 48.17A and B: Bicornuate (septate) uterus



Figs 48.18A to C: Double vaginal double cervix



Figs 48.19A and B: Two uteri fused in lower segment (3D picture)

## DISEASES OF THE ENDOMETRIUM

### *Benign condition:*

- Endometritis (Fig. 48.30)

### *Benign tumours:*

- Endometrial hyperplasia (Fig. 48.31)
- Endometrial polyps (Figs 48.32, 48.33)

### *Malignant tumour:*

- Endometrial tumours (Fig. 48.34)

## DISEASES OF THE UTERINE CAVITY

- Endometrial fluid (Fig. 48.35)
- Intrauterine contraceptive devices (Fig. 48.36)

- Synechiae (Ashermann's Syndrome) (Fig. 48.37, 48.38)

## Adenomyosis

It is defined as ectopic endometrial glands and stroma within myometrium.

### *Ultrasonographic Appearance (Figs 48.22 to 48.24)*

- Diffuse uterine enlargement with no alteration in echotexture or uterine contour.
- *Focal adenomyosis:* Poorly defined area of abnormal echotexture within myometrium.

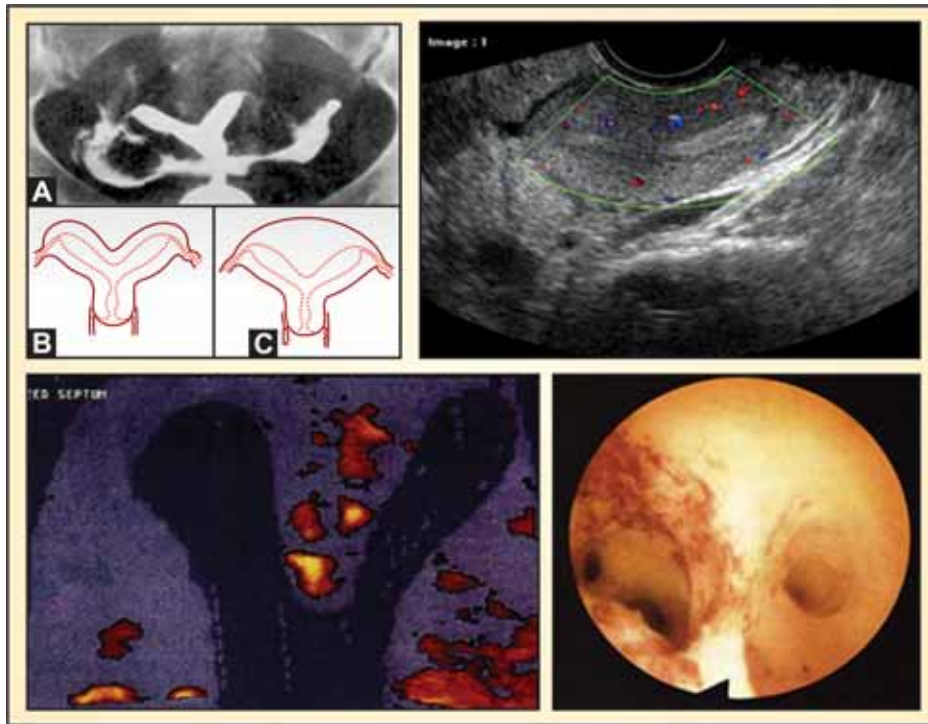


Fig. 48.20: Septate uterus

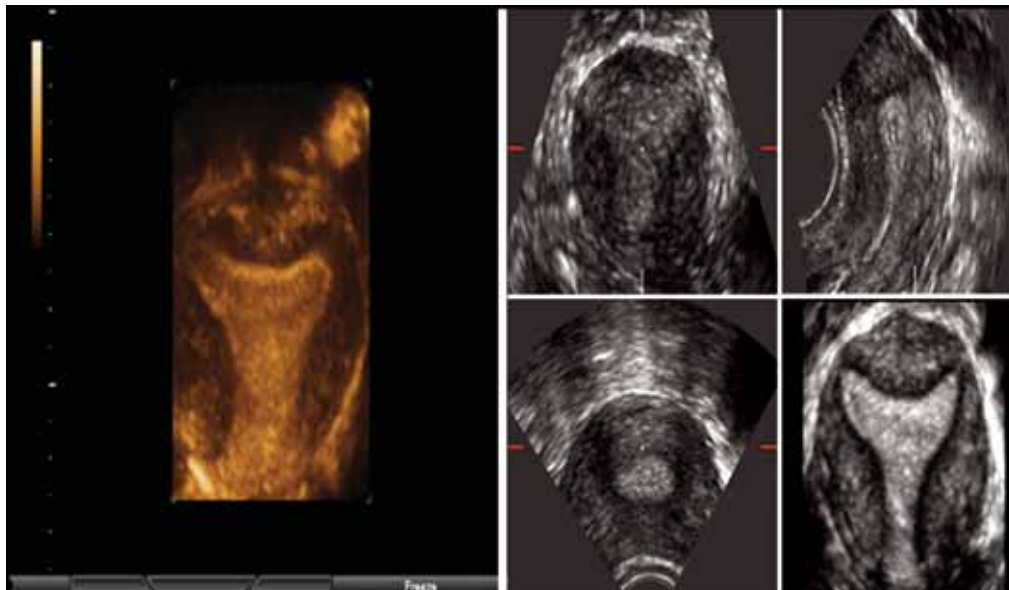


Fig. 48.21: Fundal dimpling (arcuate uterus) 3D picture

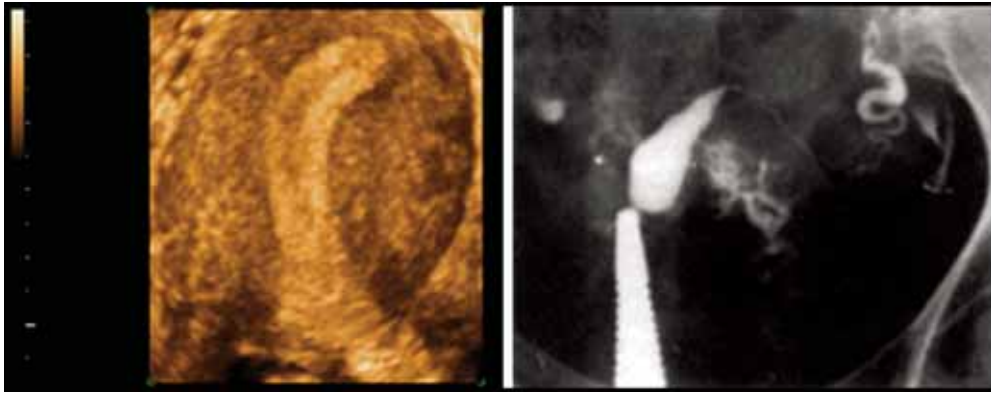


Fig. 48.21A: Unicornuate uterus

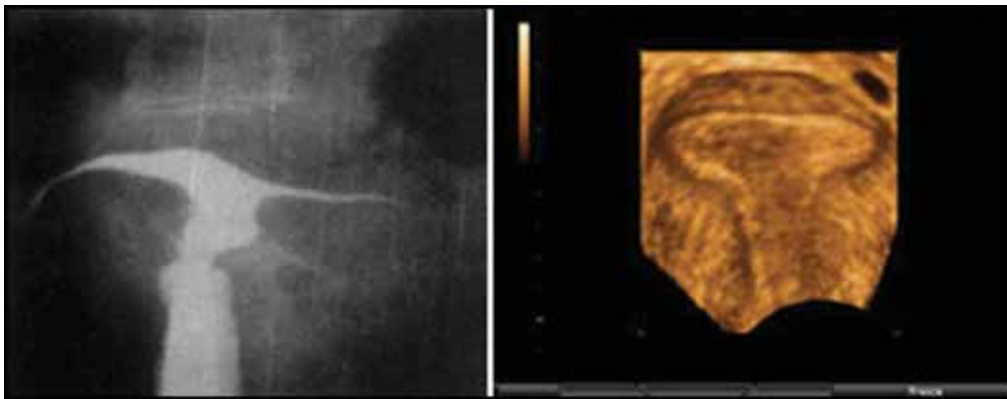


Fig. 48.21B: T-shaped uterus

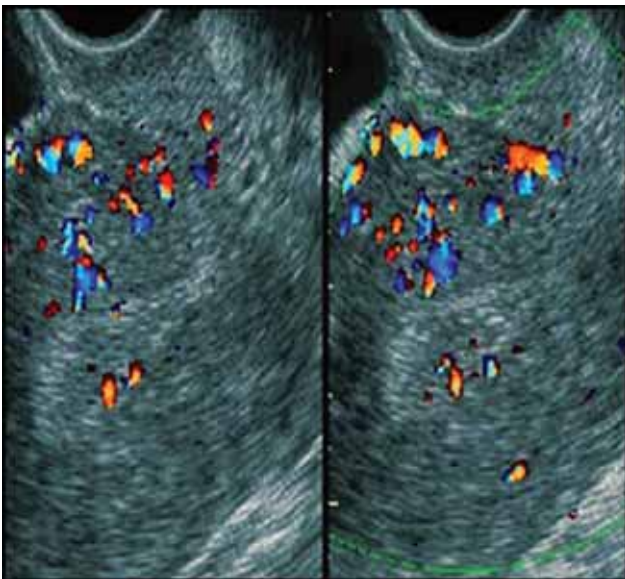


Fig. 48.22: Adenomyosis



Fig. 48.23: Adenomyosis colour

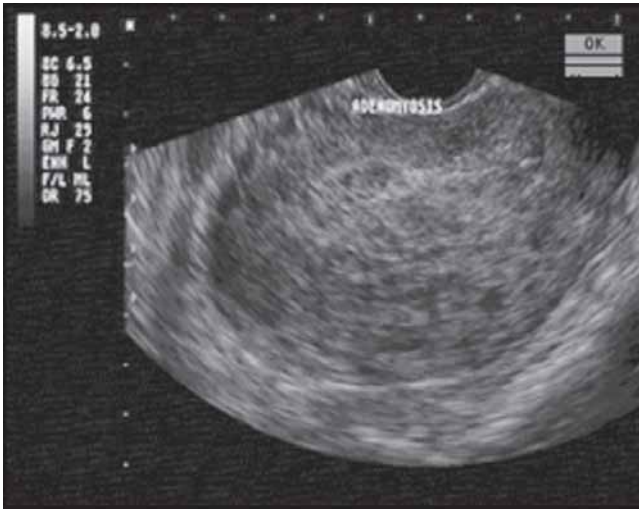


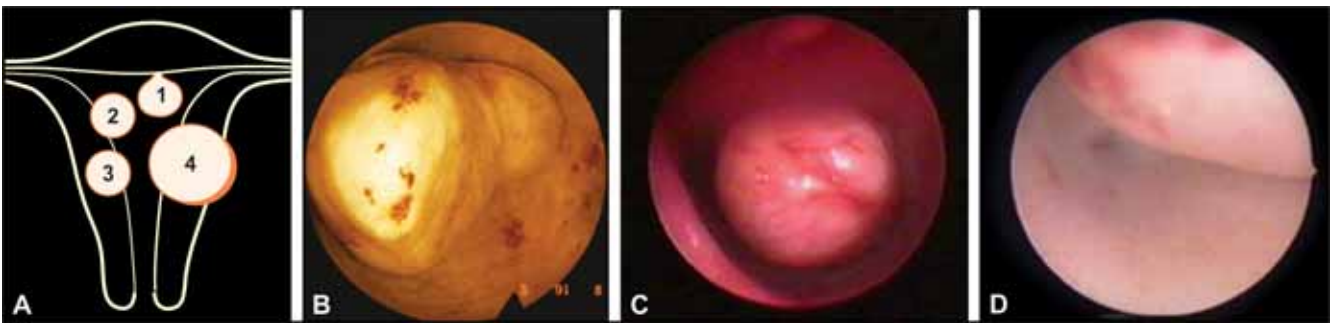
Fig. 48.24: Adenomyosis showing unequal myometrial thickness

- Focal or diffuse speckled appearance of the myometrium (salt and pepper appearance).
- Cystic areas at Endometrium-Myometrium interface (Fig. 48.39)
- Increased thickness of posterior myometrium as compared to anterior myometrium.
- Illdefined, focal abnormal texture lesion defined as adenomyoma.
- Scattered vascularity on colour flow imaging
- Additional ovaries lesions (Endometriotic cysts) may be seen. (Fig. 48.40)

### Myometritis

Ultrasonographic Findings Include (Fig. 48.41)

- Multiple bright spots within myometrium.
- Fluid in endometrial cavity.
- Fluid within pouch of Douglas.



Figs 48.25A to D: Fibroids in cavity



Fig. 48.26: Leiomyoma intramural

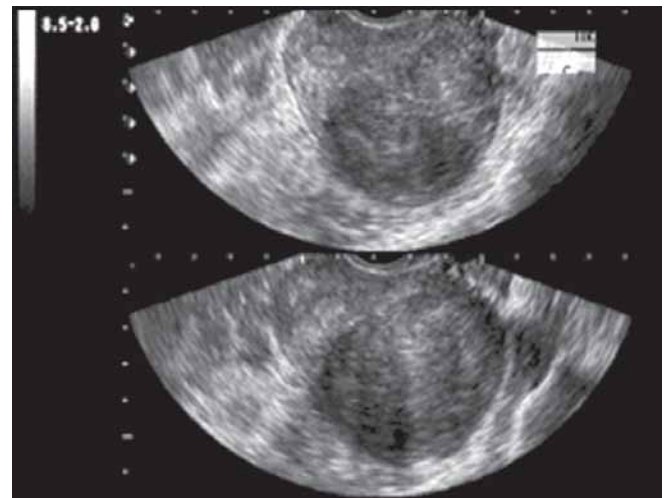


Fig. 48.27: Fibroid subserous



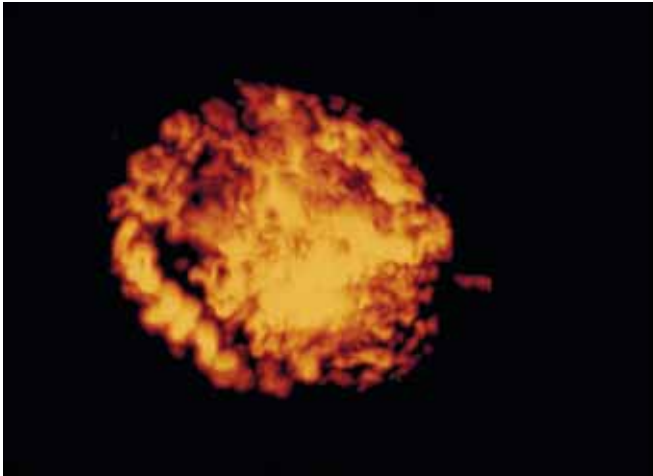


Fig. 48.28: Arteriovenous fistula

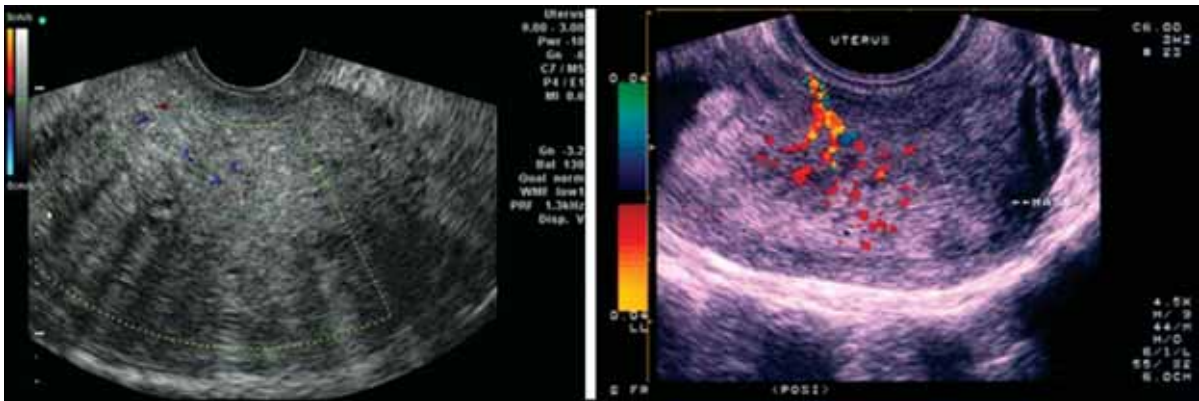
- Probe tenderness
- Blood flow pooling

### Myometrial Calcifications

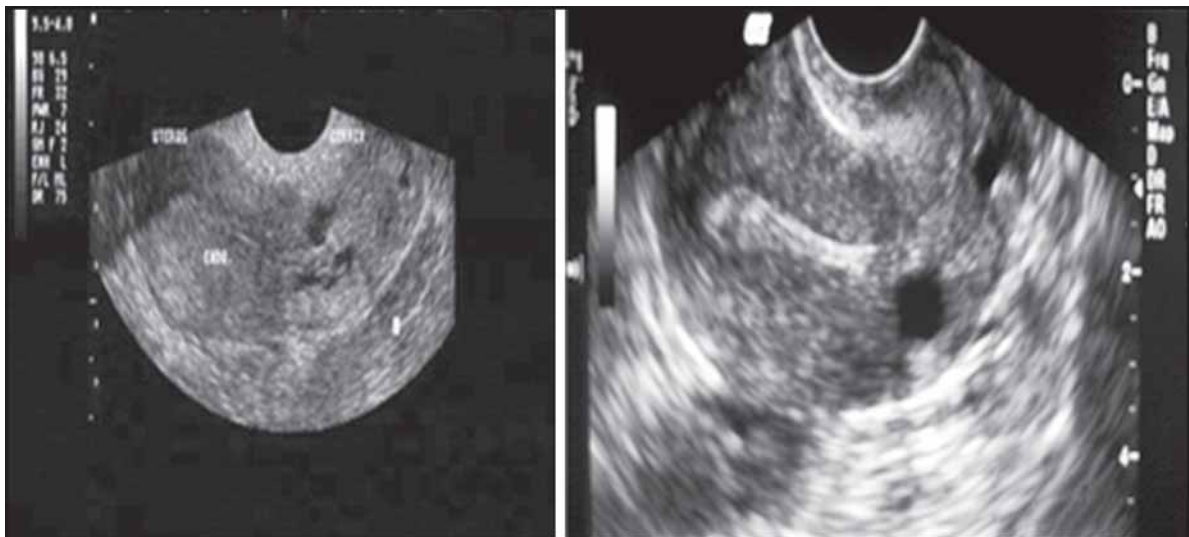
- Most common cause – calcified myoma
- Less common cause – arcuate artery calcification. (Fig. 48.42)

### Leiomyoma

These may be submucosal (5-10%) which displace/distort the endometrium. Most common type is intramural (within the wall of uterus) subserosal myomas distort the uterine cavity. Panmural myomas extend through from the outer surface to the endometrial cavity. Few myomas may have a pedicle.



Figs 48.29A and B: Malignant changes in fibroid



Figs 48.30A and B: Endometritis and cervicitis

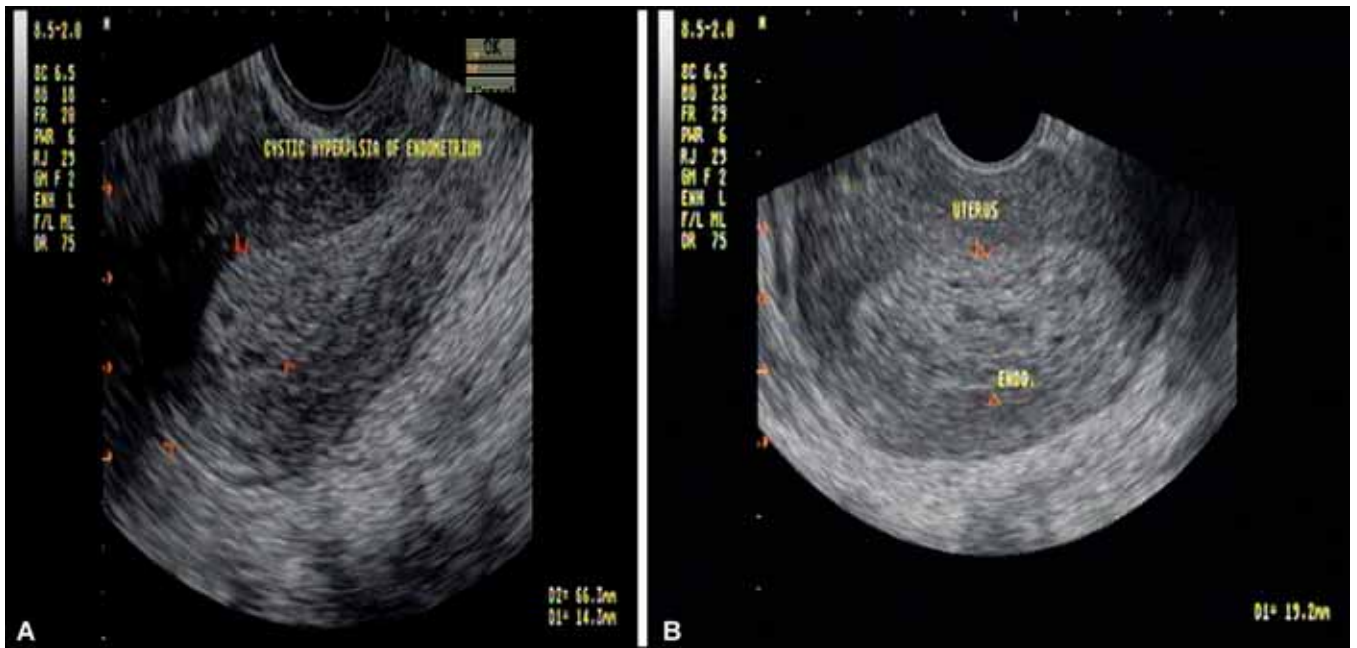


Fig. 48.31: Endometrial hyperplasia



Fig. 48.32: Polyp



Fig. 48.33: Polyp on sonohysterography

*Ultrasonographic Findings Include*

- USG appearance depends on age, site, size and composition of the tumour.
- When muscular component predominates, lesion is a well-defined, concentric mass with poor sound through transmission. (Isoechoic fibroids difficult to see by USG)
- Increasing echogenicity marks the start of fibrous degeneration. With further ageing, myomas undergo cystic degeneration (e.g. haemorrhagic, proteolytic) seen as an anechoic mass with posterior enhancement.



Fig. 48.34: Endometrial tumour (polyp)



Fig. 48.35: Endometrial fluid (sonohysterography)



Fig. 48.36: Correctly placed IUCD



Fig. 48.37: Asherman syndrome (TVS and HSG)

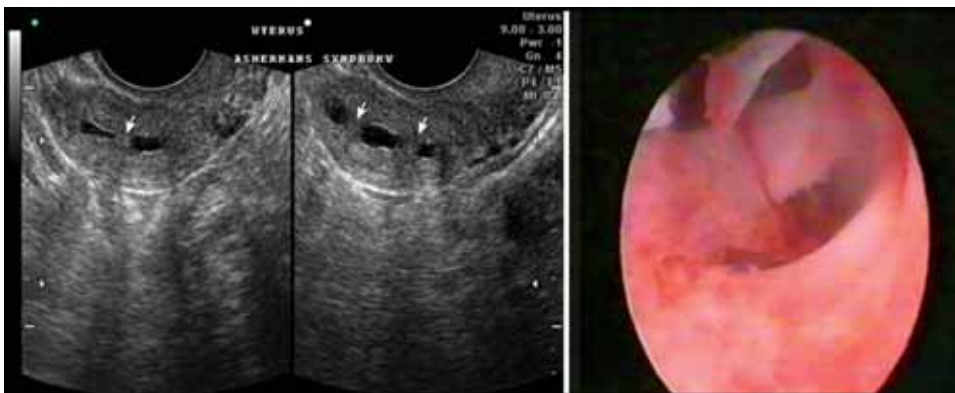


Fig. 48.38: Asherman syndrome (Sonohysterography and hysteroscopy)

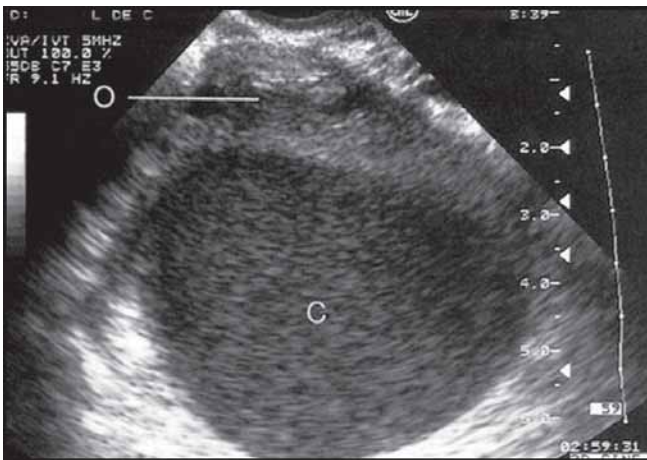


**Fig. 48.39:** Adenomyosis (endometrial-myometrial cystic areas)



**Fig. 48.42:** Myometrial and endometrial calcification

- Highly echogenic portions with acoustic shadowing is seen from areas of calcification or from myxomatous and lipomatous change.



**Fig. 48.40:** Ovarian lesions of endometriosis

### Arteriovenous Malformation

These may appear on gray scale imaging as subtle myometrial inhomogeneity, tubular spaces within the myometrium, intramural uterine mass, endometrial or cervical mass or sometimes as prominent parametrial vessels. Their appearance is non-specific. These anechoic, tubular spaces fill with colour on colour flow imaging and show low resistance flow with high peak systolic velocities on spectral analysis. Venous flow also shows high flow velocities and systolic velocity peaks similar to an arterial pattern, which suggests arteriovenous shunting. (Fig. 48.28)

### Sarcomatous Change Within Leiomyoma

- Rare condition
- Ultrasound appearance is identical to that of benign tumours.

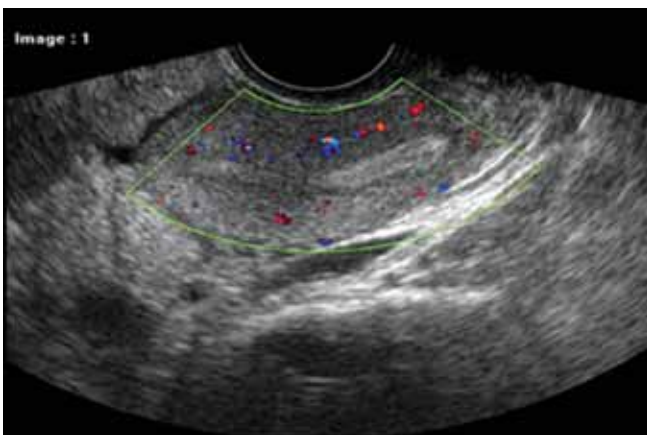
### Endometritis

Occurs with pelvic inflammatory disease and in postpartum patients.

Sonographically endometrium is echogenic or irregular with small amount of endometrial fluid.

### Endometrial Hyperplasia

It is the most common cause of vaginal bleeding in both pre and postmenopausal women, resulting from unopposed oestrogen stimulation. Sonographically the endometrium is diffusely or focally thickened. Diagnosis is confirmed by endometrial biopsy (Fig. 48.31).



**Fig. 48.41:** Myometritis (Bright spots, congestion free fluid)

### Endometrial Polyp (Figs 48.32 and 48.33)

- These represent areas of overgrowth of endometrial glands and stroma covered by endometrial epithelium.
- They usually arise from the fundus and are multiple in 20 per cent cases.
- Presents with vaginal bleeding or mucus discharge.
- Appear sonographically as areas of increased endometrial thickening. TVS shows focal irregularity of the endometrial stripe, endometrial-myometrial interface however is preserved.
- Sonohysterography confirms the diagnosis.

### Endometrial Carcinoma

- Seen in postmenopausal women with postmenopausal bleeding.
- The telltale sign of endometrial carcinoma on ultrasound is not simply thickening of the endometrium but rather focal irregularity and myometrial distortion.
- Most of endometrial carcinoma are either diffusely or partially echogenic, 10-15 per cent may be isoechoic.
- Sonography is helpful in assessing superficial or deep invasion and in follow-up management.

### Endometrial Fluid

- Physiological (menstrual phase, normal, early pregnancy)
- Pathological (abnormal pregnancy – missed abortion, ectopic pregnancy, molar pregnancy)

Infection

- Obstruction — malignant
- Cervical stenosis

### Intrauterine Contraceptive Devices (Fig. 48.43)

- Ultrasound helps to locate the position of IUCD when string is not felt.
- Seen as bright reflector within the uterus.

### Synechiea (Asherman Syndrome)

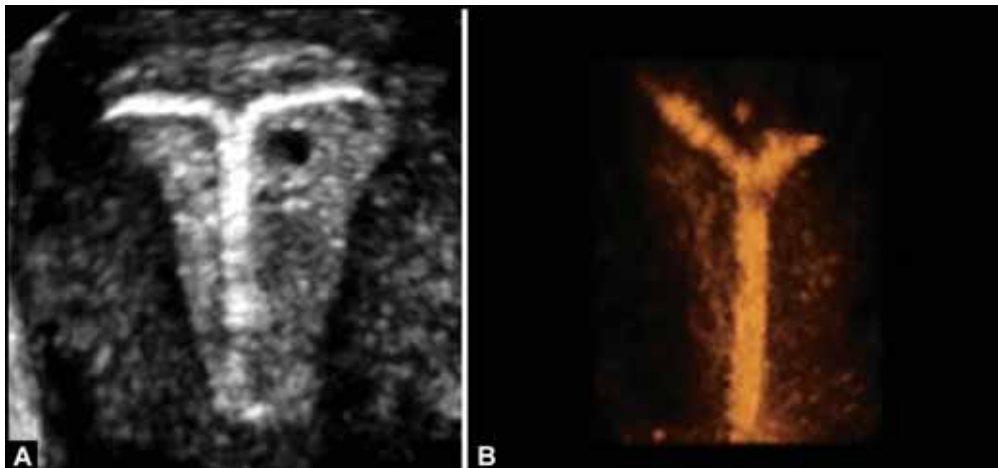
- Intrauterine fibrous adhesions cross the endometrial cavity. Synechiae form a mesh or spider's web within the uterine lumen, may cause infertility, hypo or amenorrhoea, better seen with sonohysterography. Fibrous strands may calcify, with a characteristic sonographic appearance.

### Sonohysterography (Figs 48.32 and 48.33, 48.37 and 48.38)

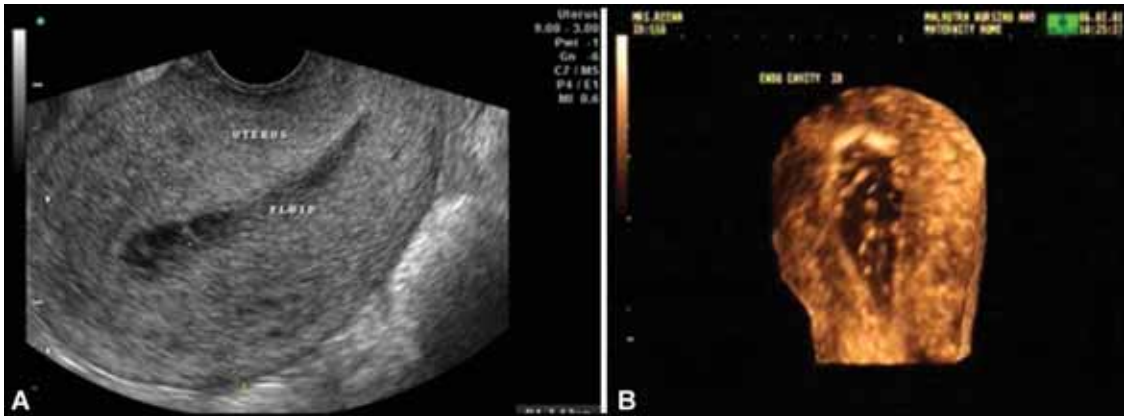
This is done by using saline contrast, which is pushed through the cervix by a paediatric foley's or feeding tube under transvaginal scan visualisation. This is an excellent, easy, non-invasive, quick and reliable method to evaluate uterine cavity for Asherman's disease, polyps, submucous fibroids, focal lesions or even malignancy.

### Ultrasound and Puerperium

Postpartum uterus should return to near normal size within 6 to 8 weeks after delivery. Postpartum ultrasound



Figs 48.43A and B: 3D and 4D picture of IUCD



**Figs 48.44A and B:** Postpartum endometritis

is visually requested if there is clinical concern about retained product or endometritis.

#### Ultrasound Finding

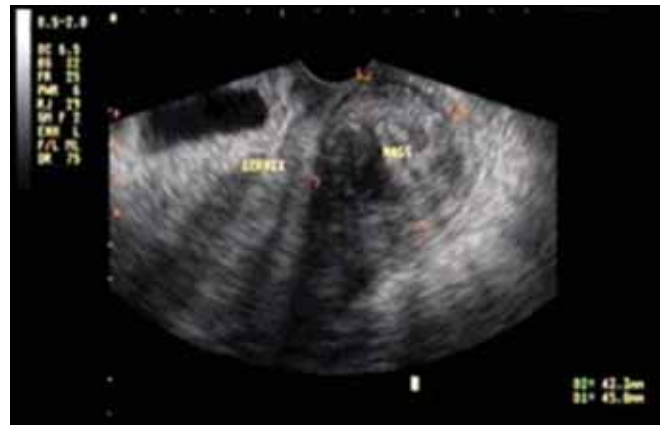
The cavity may look normal.

Echogenic mass within cavity suggestive of retained products.

Heterogenous mass may be due to retained bits, blood clot, necrotic or injected material in the absence of placental tissue.

*Fluid within endometrial cavity:* blood or infection (Fig. 48.44).

*Gas within cavity:* It may be a normal finding in puerperium, atleast until the end of 3rd postpartum weeks. May indicate infection.



**Fig. 48.45A:** Cervical fibroid

### DISEASES OF THE CERVIX

1. *Nabothian Cysts:* These are obstructed and hence dilated inclusion cysts, of no clinical relevance. May be seen at the interval os level and in the stroma, could indicate cervicitis. (Fig. 48.30)
2. *Cervical Fibroids:* Are well defined, hypoechoic masses. (Fig. 48.45A)
3. *Cervical Cancer:* Ultrasound is not especially useful in the diagnosis of cervical malignancy. USG serves to document the complications of advanced cervical disease and its treatment. For example, ultrasound can document cervical stenosis and intrauterine fluid retention or hydronephrosis (Fig. 48.45C).
4. Ultrasound also can calculate volume of mass, staging and five year survival.

### VAGINA

The most common lesion visualised with sonography are Gärtner's duct cysts. Transverse vaginal septums may present as amenorrhoea with haematocolpos (Fig. 48.45B).

### OVARIAN SONOGRAPHY

#### Benign Cystic Lesion of Ovarian and Parovarian Structures

##### Functional Cysts

- a. Follicular cysts
- b. Corpus luteum cysts
- c. Corpus luteum of pregnancy

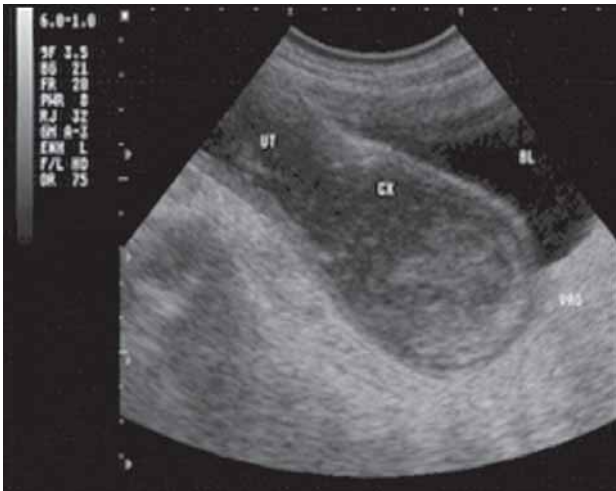


Fig. 48.45B: Transverse vaginal septum with haematocolpos

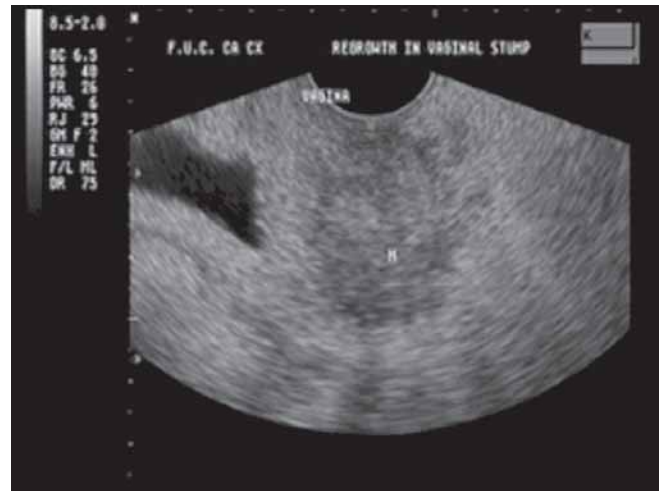


Fig. 48.45C: Cervical cancer

d. Theca luteum cysts

- Surface epithelial inclusion cysts
- Rete cysts
- Lutein cysts
- Ovarian hyperstimulation syndrome (OHSS)
- Polycystic ovarian syndrome
- Ovarian Remnant syndrome
- Neonatal ovarian cysts
- Paratubal, parovarian cysts
- Endometriosis and endometriomas
- Pelvic inflammatory disease
- Peritoneal inclusion cysts

Ovarian Vascular Lesions

- Ovarian torsion
- Ovarian oedema
- Ovarian vein thrombosis

Ovarian Neoplasms

- Surface epithelial stromal tumours
  - a. Serous tumours
  - b. Mucinous tumours
  - c. Epidermoid
  - d. Clear cell tumours
  - e. Transitional cell (Brenner's) tumours
- Germ Cell Tumours
  - a. Mature cystic teratomas (Ovarian Dermoid Cysts)
  - b. Mature solid teratoma

c. Immature teratoma

- d. Dysgerminoma
- e. Yolk sac tumours
- Sex Cord – stromal tumours
  - a. Fibroma
  - b. Thecoma
  - c. Granuloma cell tumours
  - d. Sertoli leydig cell tumours
- Metastatic tumours

Functional Cysts

- *Follicular Cysts*: Thin walled, unilocular 3-8 cm in size. Usually regress spontaneously (Fig. 48.46).
- *Corpus Luteum Cysts*: Commonly complicated by haemorrhage. Thick walled with echogenic contents (Fig. 48.47).
- *Corpus Luteum of Pregnancy*: Corpus luteum of pregnancy may become enlarged and cystic. Needs follow up ultrasound and monitoring (Fig. 48.48).
- *Theca Lutein Cysts*: Usually multilocular results from overstimulation by high levels of circulating human chorionic gonadotrophin (hCG) in trophoblastic disease (Fig. 48.49).

Surface Epithelial Inclusion Cysts

These result from cortical invaginations of ovarian surface epithelium. Mostly seen in postmenopausal women, usually multiple (Fig. 48.50).



Fig. 48.46: Thin wall follicular cysts



Fig. 48.47: Corpus luteum cyst

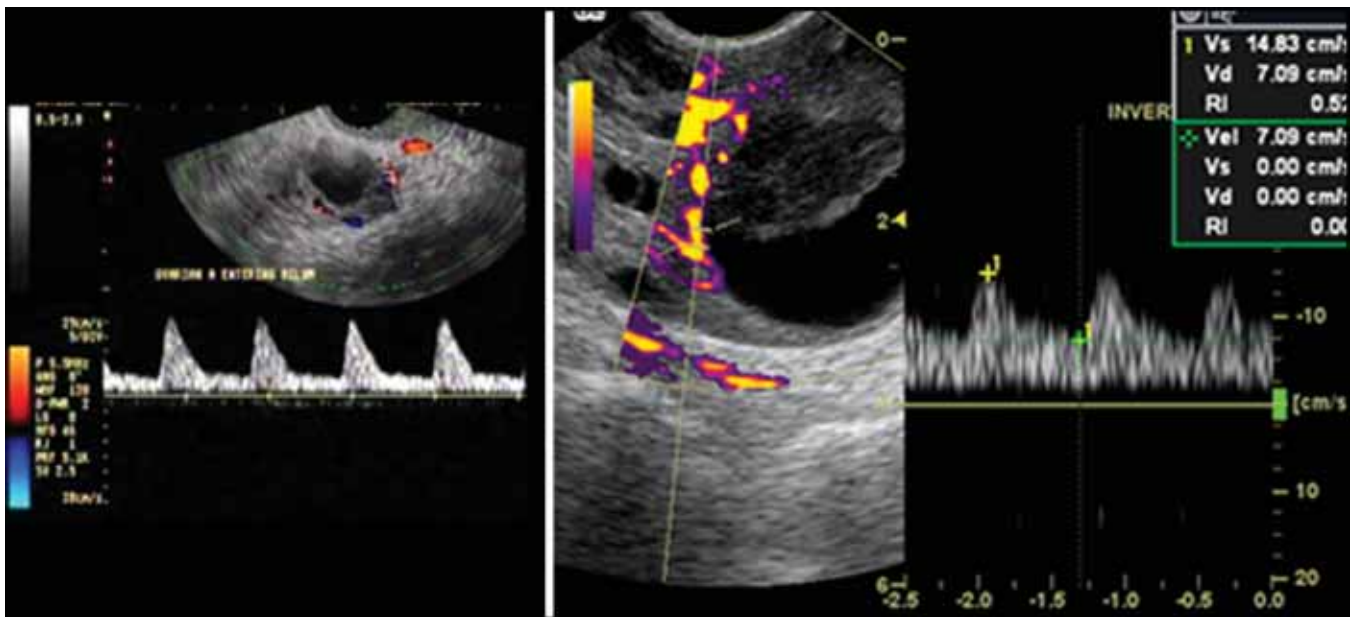


Fig. 48.48: Functioning corpus luteum blood flow

### Rete Cysts

Rare origin, located within ovarian hilus. Indistinguishable from other simple cysts (Fig. 48.51).

### Lutein Cyst

Ovarian enlargement resulting from the presence of multiple luteinised follicle cysts, secondary to hCG stimulation. Self limiting condition. USG shows

bilaterally enlarged ovaries containing multiple cysts. Cysts may be simple or have haemorrhagic contents (Fig. 48.52).

### Ovarian Hyperstimulation Syndrome

Seen in women undergoing ovulation induction, after administration of gonadotrophins followed by hCG or rarely clomiphene alone (Fig. 48.53).



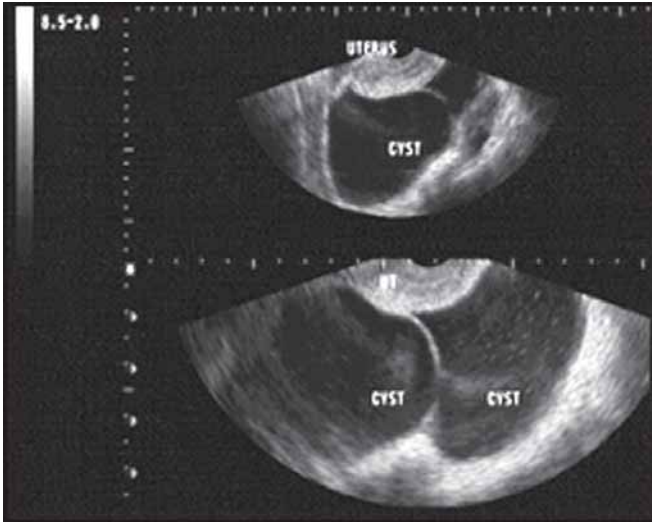


Fig. 48.49: Theca lutein cysts

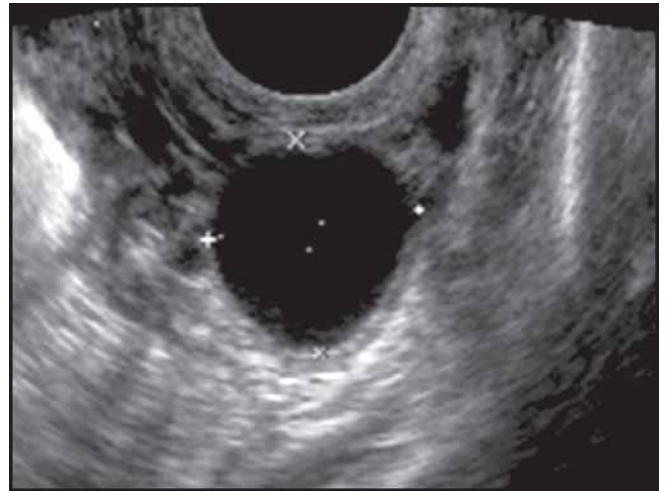


Fig. 48.51: Simple ovarian cyst

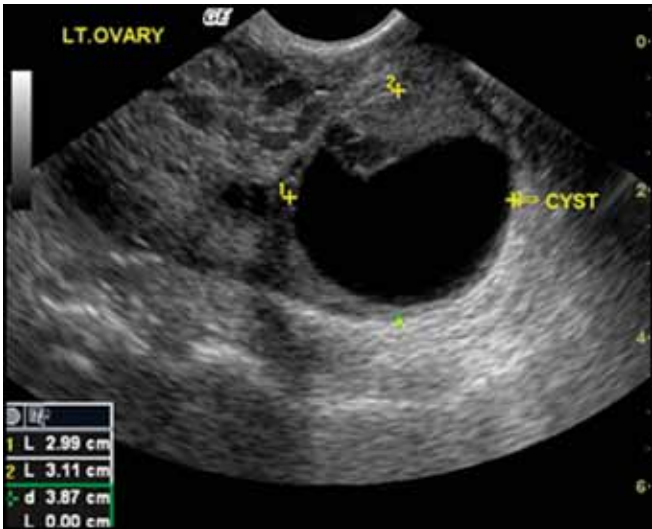


Fig. 48.50: Menopausal cystic ovaries

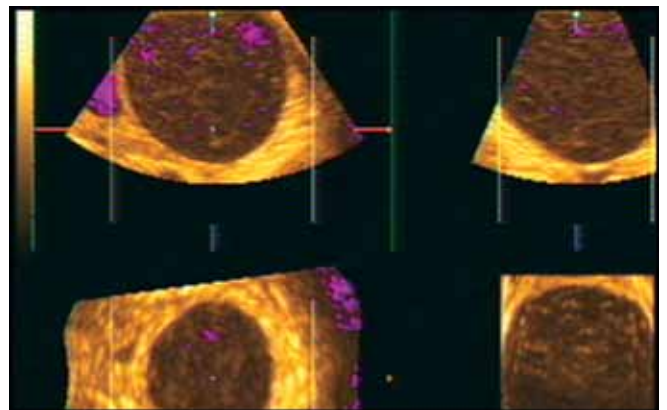


Fig. 48.52: Haemorrhagic cysts

USG: Mild to moderate OHSS (Fig. 48.11) is characterised by cystic ovarian enlargement (>5 cm in diameter) and a small amount of pelvic fluid. Severe OHSS is characterised by cystic ovarian enlargement with abdominal distension and discomfort or pain with or without nausea and vomiting or diarrhoea. Ascites and pleural effusion are seen (Fig. 48.64).

### Polycystic Ovarian Syndrome

Seen in 16 to 22 per cent of women in their reproductive years and in upto 50 per cent of women presenting to infertility clinics.

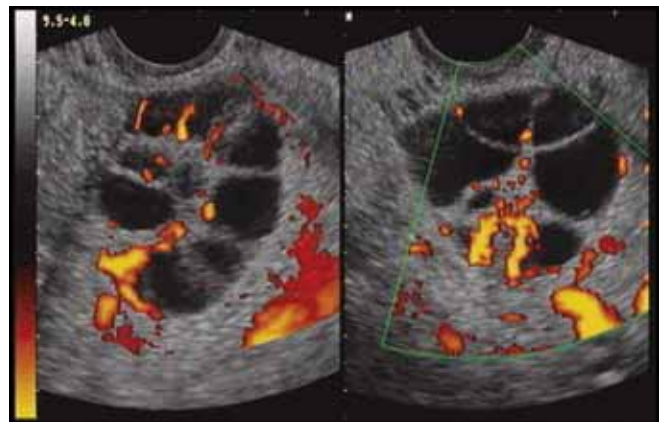
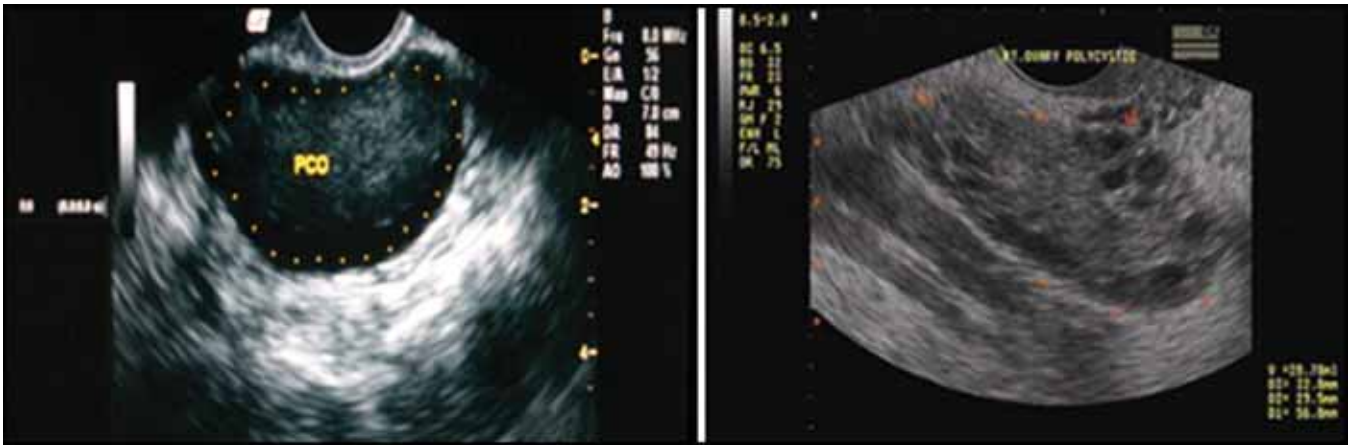


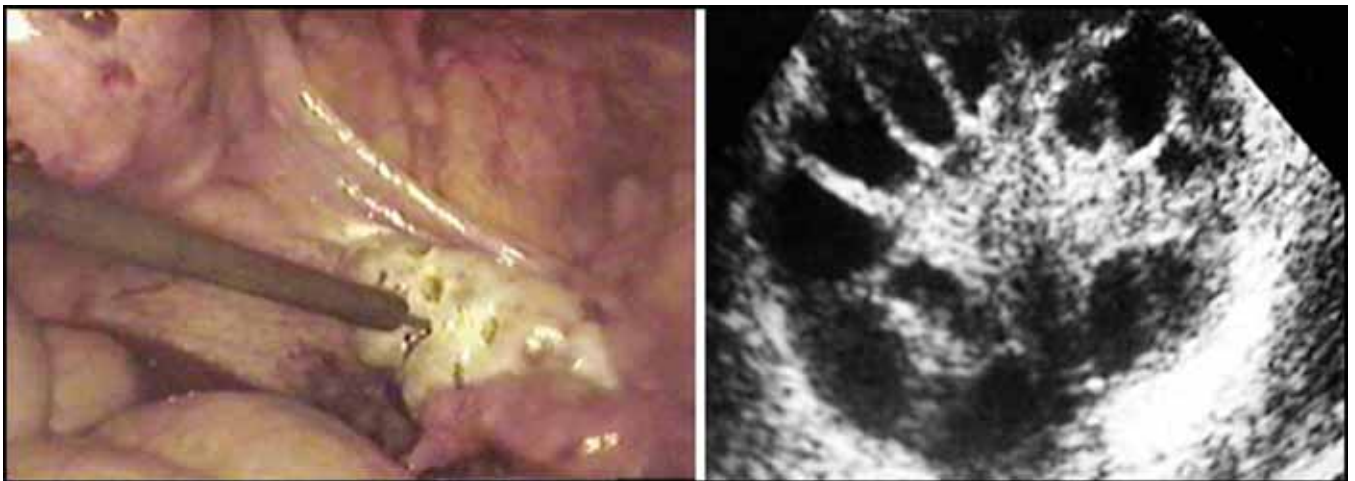
Fig. 48.53: Ovarian hyperstimulation syndrome



Necklace sign

Scattered cysts

Fig. 48.54: Polycystic ovary



Laparoscopic drilling

Enlarged ovary

Fig. 48.55: Polycystic ovarian diseases

**USG :** Typical polycystic pattern is defined by the presence of 10 or more cysts measuring 2-18 mm in diameter in a single plane arranged peripherally around an increased amount of central stroma (Garland sign or Necklace sign) (Figs 48.54 and 48.55).

Greater ovarian stromal blood flow velocity and lower impedance have been demonstrated in women with PCO. The impedance of uterine arteries has been demonstrated to be increased (Fig. 48.56).

### Ovarian Remnant Syndrome

It is a complication of oophorectomy in patients with distorted anatomy resulting from adhesions and endometriosis, making surgical dissection difficult;

residual ovarian tissue may form a cystic or complex mass (Fig. 48.57).

### Paratubal, Parovarian Cysts

These arise from the mesonephric and paramesonephric structures. Most common in third and fourth decade, may be multiple. Morphologically, these cysts are indistinguishable from simple functional cysts. They may be complicated by haemorrhage, torsion or rupture (Fig. 48.58).

### Endometriosis

It is the presence of endometrial tissue outside the endometrium and myometrium. Ovaries, uterine

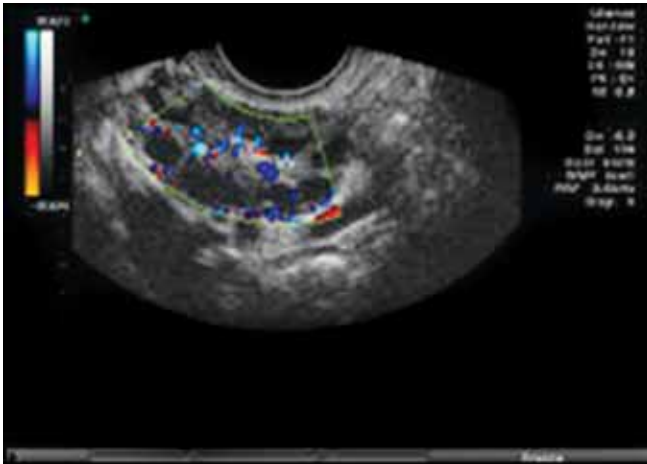


Fig. 48.56: Intrastromal flow in PCO

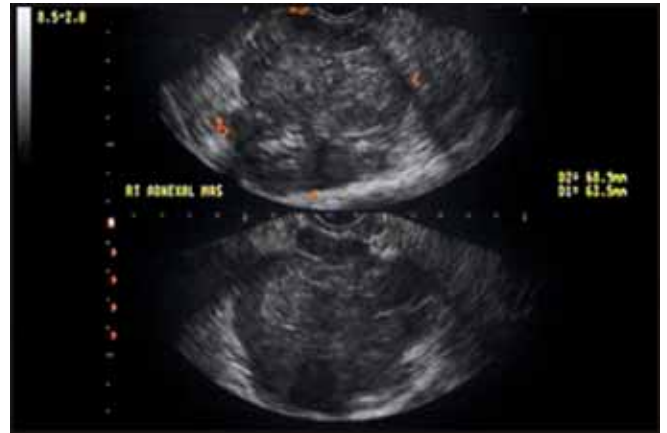
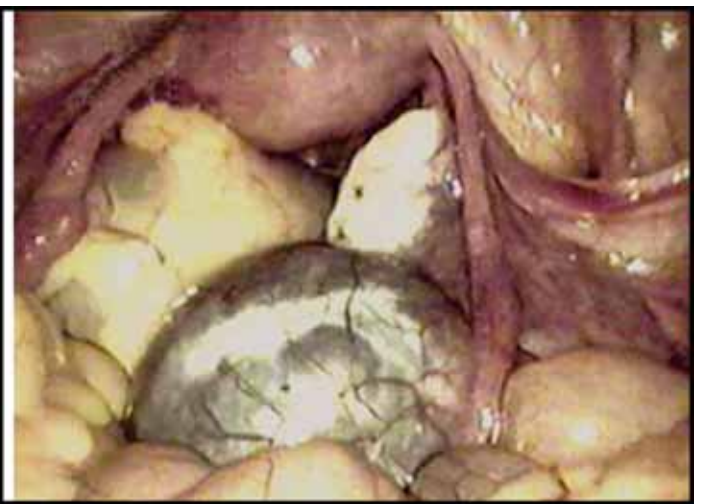


Fig. 48.57: Ovarian remnant syndrome



Ultrasound cyst drainage



Laparoscopic picture

Fig. 48.58: Paraovarian cysts

ligaments, rectovaginal septum, cul-de-sac and pelvic peritoneum are the most common sites.

**USG:** Endometriomas have a variety of appearances ranging from an anechoic cyst to a cyst containing diffuse low level echoes with or without solid components to a solid appearing mass. Presence of a fluid-fluid level, punctate or linear bright echogenic foci in the wall of the cyst favours the diagnosis of endometrioma. TVS does not detect endometriotic implants.

### Pelvic Inflammatory Disease

Ovarian involvement in PID is almost always secondary to salpingitis.

Sonographic findings may be normal early in the disease course. Timor tritsch *et al* described the sonographic findings as (Fig. 48.59):

- Thickening of tube wall  $\geq 5$  mm
- *'Cog wheel sign'*: Cogwheel shaped structure seen in cross section of tube in acute salpingitis.
- Incomplete septa correlating with folds or kinds in dilated tube.
- *'Beads-on-a-string' sign*: Hyperechoic mural nodules within fluid tube representing flattened and fibrotic endosalpingeal folds.
- *Tubo ovarian complex*: Ovary cannot be separated from the tube by pushing with the vaginal probe.

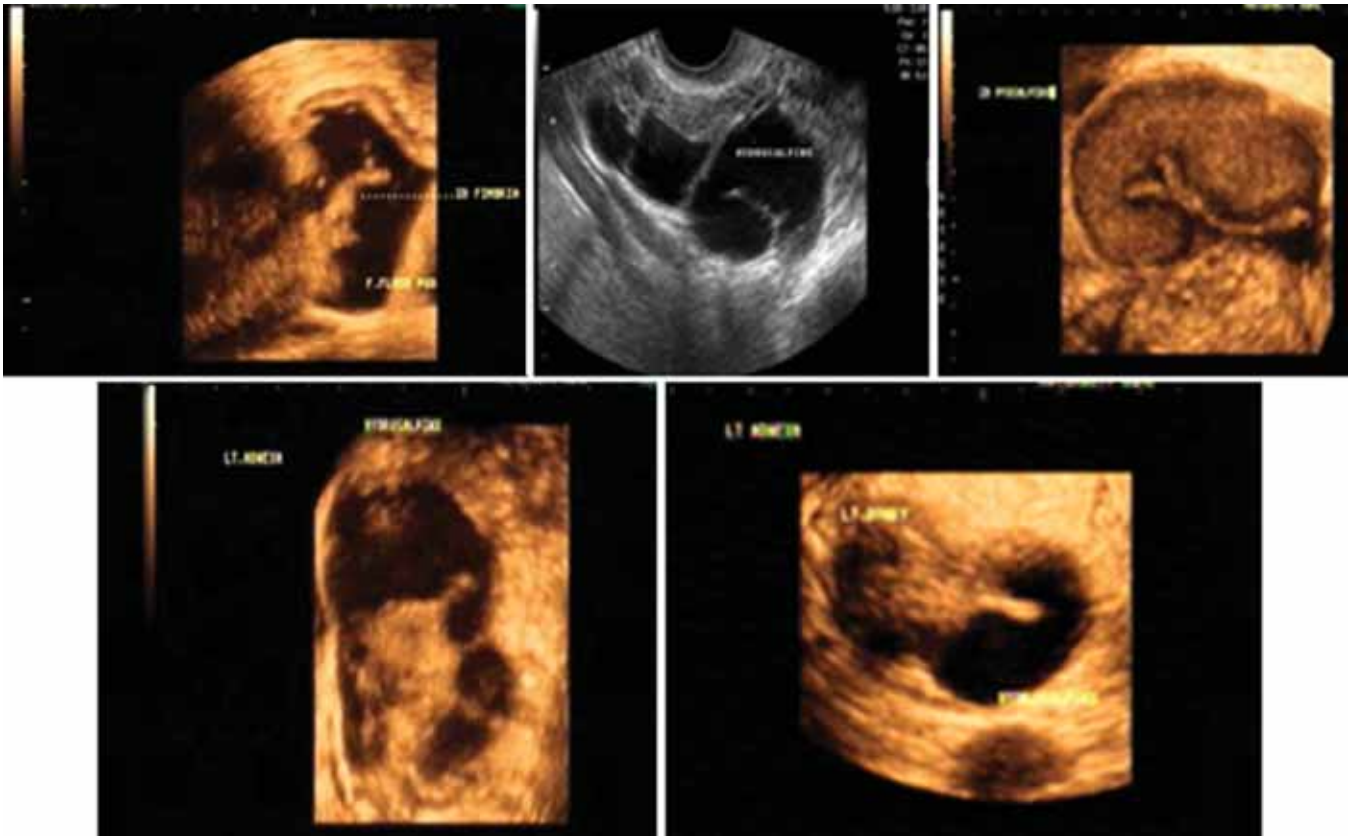


Fig. 48.59: Pelvic inflammatory disease tubal pathology

- *Tubo-ovarian abscess*: Conglomerate mass or fluid collection.
- Cul-de-sac fluid.

### Peritoneal Inclusion Cysts

These are formed by trapping of fluid (which is normally produced by active ovaries) within peritoneal adhesions. A history of trauma, abdominal surgery, PID or endometriosis is common. USG shows the ovary surrounded by septations and fluid and lies inside or in the wall of a large ovoid or irregular anechoic cyst.

### Ovarian Vascular Lesions

#### *Ovarian Torsion*

Usually caused by ovarian (particularly dermoid) and parovarian cysts. Sonographic appearance depends on the duration, degree of torsion and any associated intraovarian mass. USG shows a cystic, solid or complex mass with or without pelvic fluid, thickening of wall.

These findings however are non-specific. Enlargement of ovary with absent or markedly diminished ovarian flow is a specific finding (Fig. 48.60).

#### *Massive Ovarian Oedema*

Accumulation of edema fluid within ovarian stroma, most likely due to torsion of the ovary. A definitive diagnosis of massive ovarian oedema cannot be made on preoperative imaging but should be considered in the differential diagnosis of a solid extrauterine mass in the appropriate clinical setting.

#### *Ovarian Venous Thrombosis*

Occurs most often postpartum, may also follow pelvic operations, pelvic trauma — sonographically thrombosed vein appears as an anechoic to hypoechoic tubular mass extending superiorly from the adnexa with absence of flow on Doppler. A perivenous phlegmon with increased vascularity may be seen.

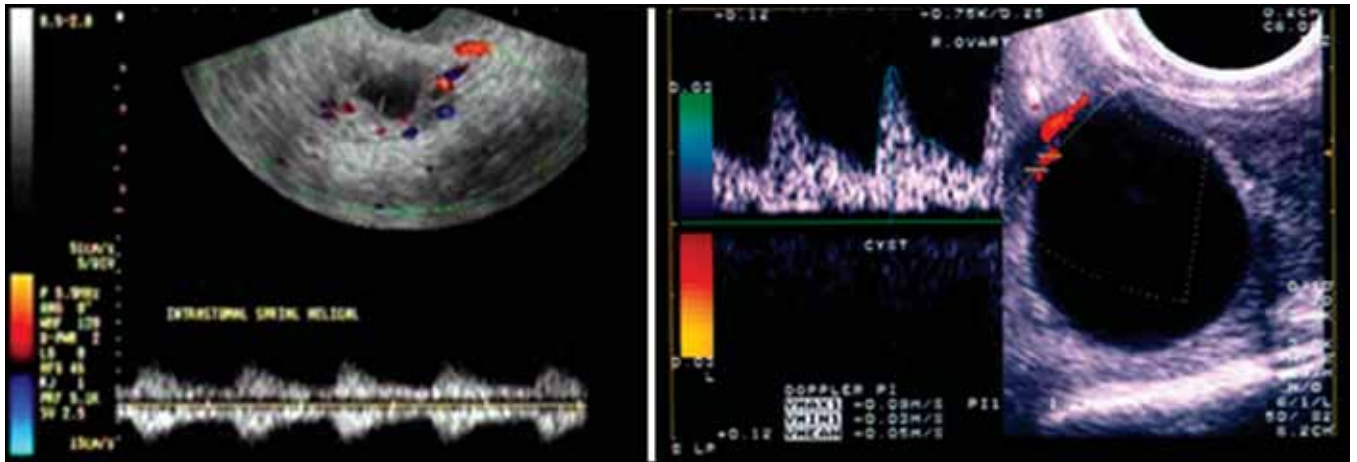


Fig. 48.60: Ovarian vessels

## OVARIAN NEOPLASMS

### Surface Epithelial Stromal Tumours

#### Serous Tumours

Benign serous cystadenomas appear as sharply margined, anechoic masses that may be large and are usually unilocular. Internal thin walled septations and papillary projections may be seen (in borderline tumours) (Fig. 48.61).

Serous cystadenocarcinomas are usually multilocular, containing multiple papillary projection and septations; echogenic material is occasionally seen within the loculi.

#### Mucinous Tumours

Sonographically, mucinous cystadenomas have thicker and more numerous septations and frequently contain fine, gravity-dependent echoes produced by thick contents.

Mucinous cystadenocarcinomas usually appear as large, multiloculated cystic lesions containing echogenic material and papillary excrescences (Fig. 48.62).

Pseudomyxoma peritonei is by far the most common manifestation of atypically proliferating mucinous tumours.

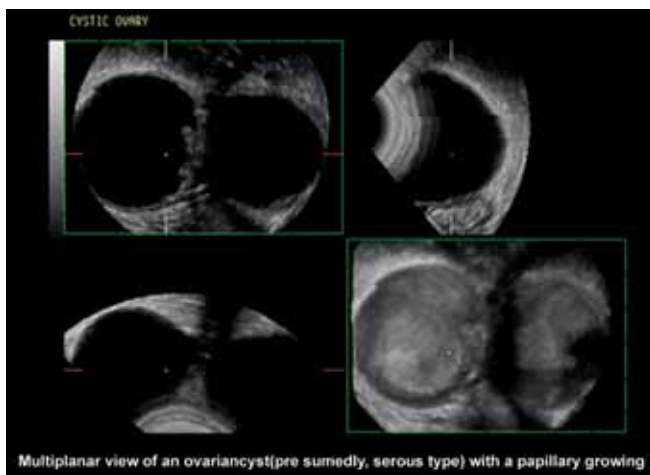


Fig. 48.61: Serous tumours of ovary

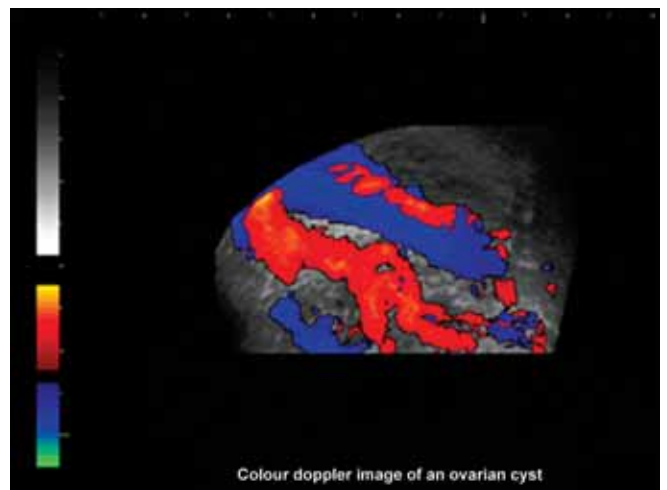


Fig. 48.62: Surface vasculature ovarian cyst

### Endometrioid Tumours

**USG:** These tumours are seen as cystic masses containing papillary projection (Fig. 48.63).

### Clear Cell Tumours

Sonographic features of clear cell tumours are non-specific, usually seen as complex, predominantly cystic masses (Fig. 48.64).

### Transitional Cell Tumours (Brenner's Tumour)

These are usually small (1-2 cm), hypoechoic and solid. Extensive calcification may be seen cystic areas are unusual.



Fig. 48.63: Endometrioid tumours

### Germ Cell Tumours

1. *Mature cystic teratomas (Ovarian Dermoid):* USG features include the presence of regional diffuse bright echoes with or without posterior acoustic shadowing, hyperechoic lines or dots, shadowing echodensity and a fluid-fluid level (Figs 48.65 and 48.66).
2. *Immature teratomas:* These are rare malignant tumours, usually large and predominantly solid.
3. *Struma ovarii:* This term is used for tumours (mature cystic teratomas) containing thyroid tissue.
4. *Dysgerminoma:* Sonographically, the presence of a solid ovarian mass with a multilobulated appearance separated by fibrovascular septa, is highly suggestive.
5. *Yolk sac tumours:* Similar in appearance to that of Dysgerminomas.

### Sex Cord – Stromal Tumours

1. *Fibromas:* Meig's syndrome complicates about 1 per cent of ovarian fibromas and is defined as ascites and pleural effusion accompanying a fibrous ovarian tumour usually a fibroma. Two typical appearances have been described sonographically. The first has features similar to that of uterine fibroid. Second appearance is that of a hypoechoic mass with substantial attenuation.
2. *Thecoma:* Sonographically, these tumours are similar in appearance to fibromas.
3. *Granulosa cell tumours:* Sonographically small tumours are predominantly solid, having an echogenicity

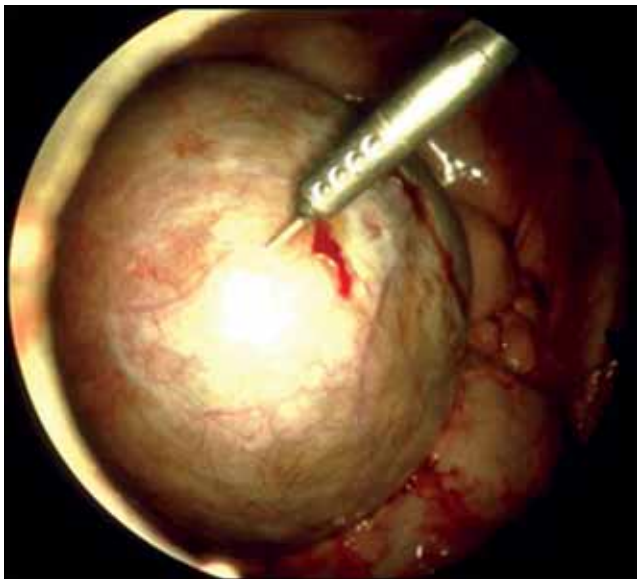


Fig. 48.64: Clear cysts (Laparoscopy)



Fig. 48.65: Dermoid

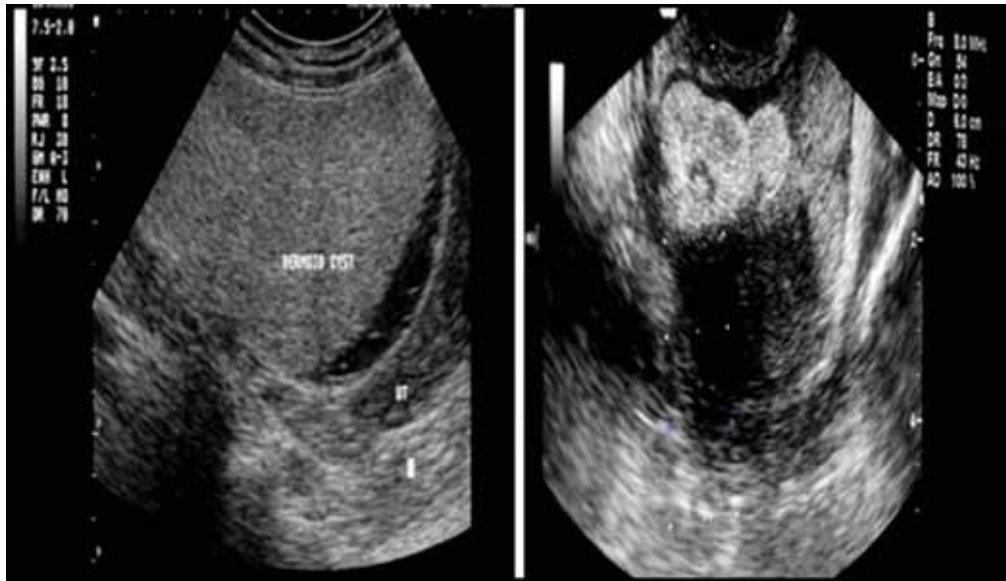


Fig. 48.66: Big dermoids

similar to that of fibroids. Large ones resemble cyst adenomas and are multiloculated and cystic.

4. *Sertoli-Leydig Cell Tumours*: Similar in appearance to granulosa cell tumours.

### Metastatic Tumours

Tumour spread to ovaries is by several routes :

1. *Direct spread*: Carcinomas of fallopian tube and uterus, colonic carcinomas and retroperitoneal sarcomas.
2. Through the lumen of fallopian tube onto the surface of ovary. Uterine corpus carcinoma.
3. Distant site metastatic deposits via blood and lymphatics.
4. Trans-coelomic dissemination with surface implantation.

*USG*: Bilateral ovarian enlargement by solid masses is highly suggestive. These masses may contain hypoechoic areas that represent cystic degeneration or necrosis.

*Ovarian Lymphoma*: Solid hypoechoic masses.

### Evaluation of an Ovarian Mass

1. *Morphologic parameters*: Benign tumours are usually unilocular, well defined borders, thin walls or septa.

Malignant tumours are multilocular, have thick or irregular walls or septa, poorly defined borders, mural nodules, solid components and echogenic elements.

2. *Doppler parameters*: Neovascularity is a feature of malignant tumours and is characterised by 1000 impedance, high velocity flow. Most authors used a cut off for malignancy of less than 0.4 for RI and 1.0 for PI.
3. *Colour flow mapping*: Peripheral vascularisation appears to be more common in benign tumours, whereas malignant tumours tend to have more centrally located vessels.

Arrangement of vessels is also a helpful discriminator because benign masses tend to have regularly spaced vessels, whereas malignant tumours demonstrate random distribution of vessels.

Absence of diastolic notch has been associated with malignant tumours.

## GESTATIONAL TROPHOBLASTIC DISORDERS

### Complete Hydatidiform Mole

Snowstorm appearance on sonography without associated embryonic or foetal structure. Large



Fig. 48.67: Hydatiform mole



Fig. 48.68: Pelvic kidney

sonolucent areas result from stasis of maternal blood between the molar villi. Theca lutein cysts are seen. High serum  $\beta$ -hCG levels combined with sonographic appearance is highly indicative of the disease. Doppler shows high velocities and low resistance flow in uterine arteries (Fig. 48.67).

A complete mole may co-exist with a normal foetus and placenta in cases of molar transformation of one ovum in a dizygotic twin pregnancy.

### Partial Hydatidiform Mole

Refers to the combination of a foetus with localised placental molar degeneration. In 90 per cent of cases, partial moles are triploid, having inherited 2 sets of chromosomes from the father and one from the mother. Partial mole presents on ultrasound as an enlarged placenta containing multicystic, avascular sonolucent spaces. (Swiss Cheese Appearance). Foetus show symmetric IUGR and malformations.

### Invasive Hydatidiform Mole

It is defined as the penetration of molar villi from a CHM or PHM into the myometrium or the uterine vasculature. Sonographically it appears as focal areas of increase echogenicity within the myometrium. The lesion is heterogenous, often containing fluid filled cavities.

### Placental Site Trophoblastic Tumour

It is the rarest form of GTD. Sonographically it is similar in appearance to invasive mole.

### Choriocarcinoma

It is a highly malignant tumour that metastasises to lungs, liver and brain. Sonographically it appears as a solid, echogenic mass with cystic areas suggestive of haemorrhage.

### Pelvic Kidney (Fig. 48.68)

Rarely ectopic kidney is visualised in the pelvis and may mimic abnormal T-O masses.

### SUMMARY

Pelvic sonographic imaging is the technique of choice for evaluation of pelvic organs and is a very commonly performed examination for vaginal bleeding and pelvic pain, the main roles are to determine the presence of lesion, its origin and whether surgery is required. Where there is difficulty, a tailored MRI examination can be helpful.

### CONCLUSION

Transvaginal ultrasound is a very good, reliable, reproducible, easy, safe method to evaluate the female pelvis and very accurate for gynaecological diagnosis.



# CHAPTER 49

## Endoscopic Surgery in Gynaecology

Laparoscopy	767
Hysteroscopy	778

Endoscopy means “looking inside” and typically refers to looking inside a hollow viscus or a body cavity using an instrument called an endoscope. The first “endoscopy” was performed in 1901 using a Nitze cystoscope on a dog. Shortly after this milestone, Jacobaeus in 1911, reported abdominal and thoracic endoscopy on humans. In 1938, the first major technical advance occurred with the development of the Veress needle for insufflation. Additional instrumental developments followed with the invention of automatic insufflators, lighting systems, video systems, and computer chips.

### LAPAROSCOPY

Laparoscopy, also called *minimally invasive surgery* (MIS), or *keyhole surgery*, is a technique in which operations in the abdomen are performed through small incisions as compared to larger incisions needed in open surgery. Laparoscopic surgery includes operations within the abdominal or pelvic cavities. Laparoscopy was initially used primarily for diagnosis in cases of chronic pelvic pain, pelvic masses, or for the suspicion of an ectopic pregnancy. The first surgical intervention to be performed by laparoscope was tubal sterilisation. With advances in technology and instrumentation as many as 80 per cent of gynaecological operations can now be performed endoscopically.

### Advantages

When compared to conventional open surgery it has the following advantages:

- Rapid postoperative recovery
- Less postoperative pain and reduced need of postoperative analgesia
- Although procedure times are usually slightly longer, hospital stay is less, and often with a same day discharge which equals a faster return to everyday living.
- Reduced exposure of internal organs to possible external contaminants thereby reduced risk of acquiring infections and postoperative adhesions.
- Less adhesion formation
- Reduced blood loss, which equals less risk of needing a blood transfusion.
- Smaller abdominal scars (cosmetic value).

## Disadvantages

Fundamentally laparoscopic surgery differs from its laparotomic counterpart only by its particular mode of access. However, it is intrinsically more difficult to perform than laparotomy due to:

- Indirect palpation of tissues through a finite number of immovable ports
- Restriction of axial freedom
- Replacement of normal stereoscopic three-dimensional visualisation by two dimensional video image
- Higher initial expenditure (instrument cost).

Despite these challenges, given proper surgical case selection and the requisite surgical training, it promises to result in at least equivalent results, better cosmesis, less postoperative pain and faster recovery.

## Indications For Laparoscopy

### Diagnostic Laparoscopy

#### Non-acute conditions

- Evaluation in infertility
- Chronic pelvic pain
- Suspected endometriosis
- Evaluation of müllerian anomaly
- Prior to tuboplasty

#### Acute conditions

- Acute abdominal pain
- Suspected ectopic pregnancy
- Acute pelvic inflammatory disease
- Torsion of adnexa

## Operative Laparoscopy

In addition to providing diagnostic accuracy, the laparoscope may be used to safely carry out many surgical operations. The indications for these procedures are the same as for laparotomy (Table 49.1).

Laparoscopy has a more limited place in the primary staging, treatment, and follow-up of patients with gynaecological malignancies, but radical hysterectomies, pelvic and para-aortic lymphadenectomies have been performed laparoscopically.

## Contraindications To Laparoscopy

### Absolute

- Mechanical or paralytic ileus
- Large abdominal mass (>24 weeks gestation size)

**Table 49.1: Operations performed through Laparoscopic approach**

#### Operation on Uterus

- Correction of Müllerian anomalies (rudimentary horn excision)
- Myomectomy (subserous/intramural)
- Hysterectomy for benign indications (LAVH, Total laparoscopic Hysterectomy)
- Hysterectomy for malignant conditions

#### Operations on Adnexa (Conservative)

- Ovariolysis/Fimbriolysis/Salpingolysis
- Puncture of ovarian cysts
- PCOD drilling
- Ovarian cystectomy
- Fimbrioplasty
- Cuff Salpingostomy/Salpingoneostomy
- Linear salpingotomy in ectopic pregnancy
- End to end anastomosis (reversal)
- Removal of paraovarian cysts

#### Operations on Adnexa (Radical)

- Oophorectomy
- Salpingectomy (partial/total)
- Tubal sterilisation
- Adnexectomy

#### Laparoscopy in Endometriosis

- Peritoneal deposits Coagulation/Excision/laser vaporisation
- Endometrioma drainage/fulguration of lining/cystectomy
- Adhesiolysis (salpingolysis/ovariolysis/omental adhesiolysis)

#### Laparoscopy for genital suspension operations

- Burch Colposuspension
- Sacrofixation of vagina (vault prolapse)
- Correction of cystocele/rectocele/enterocele
- McCall culdoplasty

#### Other indications

- Appendectomy
- Evaluation in Ascites
- Laparoscopy during pregnancy
  - Second look laparoscopy

- Shock
- Medical conditions precluding surgery
  1. Severe obstructive airway disease
  2. Cardiorespiratory failure
- Irreducible external hernia

### Relative

- Multiple abdominal incisions
- Generalised peritonitis
- Hiatus/Diaphragmatic hernia
- Blood dyscrasias and coagulopathy
- Extreme obesity
- Advanced pregnancy

### Equipment For Laparoscopy

**Laparoscope** – Rod lens system allows a clear undistorted view. Laparoscopes are available in various sizes (2 mm, 5 mm, 10 mm) and viewing angles (0°, 30°) (Fig. 49.1). The larger the diameter of the optic, better is the panoramic view of the pelvis. Telescope with 30° viewing angle is useful during suturing and complex surgical procedures.

**Single puncture telescope** has a telescope with a channel which allows passage of 5-8 mm instrument (band applicator for sterilisation, scissors, bipolar or monopolar forceps, laser fibre).

**Double puncture telescope** has optics only. Accessory ports are required to pass instruments to perform surgery.

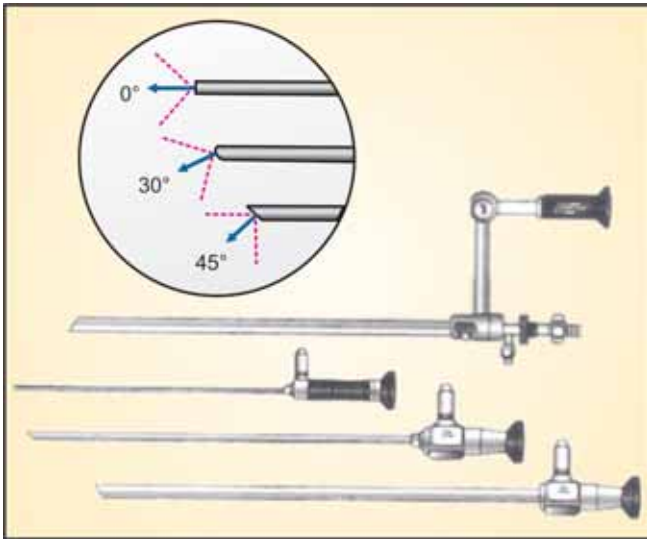


Fig. 49.1: Various types of telescopes



Fig. 49.2: Halogen light source with cable

**Light Source** – High intensity halogen (250W) (Fig. 49.2) or Xenon light is transmitted to the telescope for excellent visualisation through fibre optic cables.

**CO<sub>2</sub> Insufflator** – It is used to create safe pneumoperitoneum. Modern insufflators are automatic, high flow (20 L/min) pressure limited (12–15 mm) machines to maintain constant intra-abdominal pressures (Fig. 49.3).

**CCD Camera** – This camera with single chip or three chips (separate chip for three primary colours) attaches to the telescope eyepiece (Fig. 49.4). The camera unit is connected to a monitor to view the images of the operative field. Images can be recorded using still camera, video or DVD recorders or directly on the computer using dedicated software.

**Verres needle** – The CO<sub>2</sub> gas is delivered into the abdominal cavity using a spring loaded needle. The inner blunt tip springs out when it enters the peritoneal cavity preventing visceral injury.



Fig. 49.3: High flow electronic insufflator



Fig. 49.4: CCD camera

**Trocar and cannula** – Available in various sizes to match the telescopes, they are inserted through the abdominal wall (umbilicus) following pneumoperitoneum (Fig. 49.5). The trocar is removed and the telescope introduced through the cannula. A port in the cannula allows gas to be delivered into the peritoneal cavity.

### Ancillary Instruments

**Blunt Probe:** It is the simplest instrument used to stabilise or manipulate organs. Probes that are marked in centimeters are useful as the magnification of the laparoscope can make estimation of size difficult.

**Graspers:** A range of graspers (atraumatic, allis type, spoon forceps, claw forceps) of different sizes and designs is essential in any laparoscopic procedure (Fig. 49.6). Atraumatic forceps hold tube, ovary and bowel delicately. Allis type forceps are essential for performing cystectomy in ovarian cyst or endometriomas. Spoon forceps can be used to extract trophoblastic tissue from salpingostomy site. Claw forceps give a firm grip for tissue extraction through cannula sleeve.

**Scissors:** They are available in various shapes (Straight, curved, Metzenbaum, hook) (Fig. 49.7), they are essential for cutting adhesions, dissection and cutting pedicles. Microscissors are available for fine dissection and cutting delicate tissues.

**Aspirators and Irrigators:** Needle tipped aspirators are used for aspiration of ovarian cysts, cul-de-sac fluid for cytologic or microscopic examination. Wide bore suction/irrigation cannulas are used to quickly evacuate haemoperitoneum in an ectopic pregnancy (Fig. 49.8).

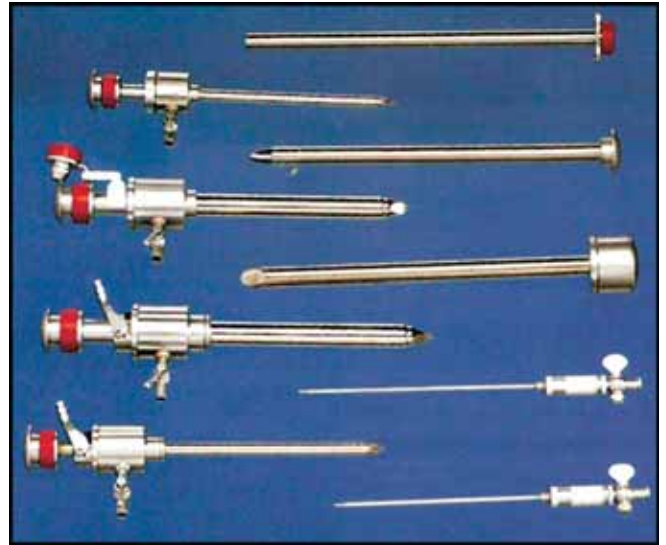


Fig. 49.5: Trocar and Cannula/verres needle

Irrigation is essential to maintain a clear view in the pelvis during operative laparoscopy.

**Needle holders:** Needle holders with various designs and handle shapes are available for needle handling during suturing. Although suturing is often unnecessary, certain procedures are facilitated by its use (myomectomy, tubal reanastomosis, Burch colposuspension). Any type of suture material or needle can be used laparoscopically. Curved needles make suture placement easier, and are introduced through a trapless trocar sleeve.

Two types of suturing techniques are available:

**Extracorporeal suture:** After the suture is passed through the tissue, both ends are brought back out of the

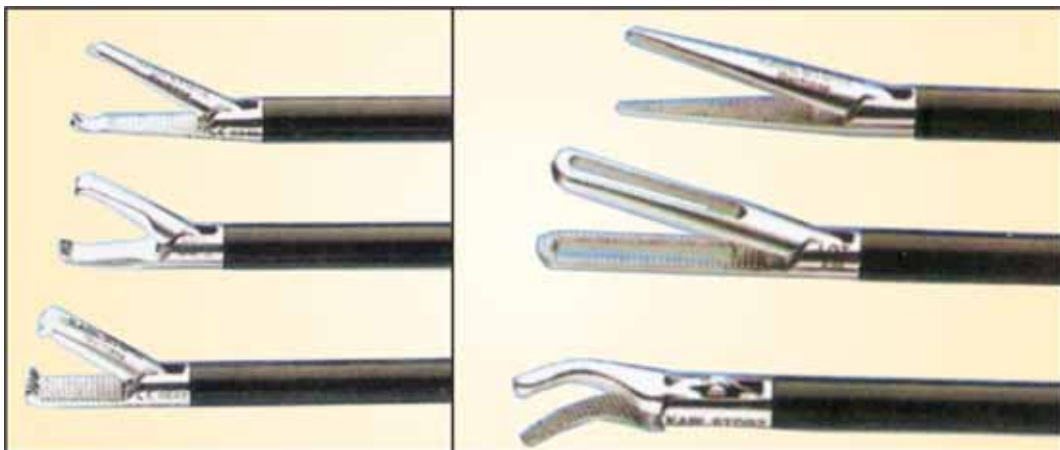


Fig. 49.6: Various types of graspers



Fig. 49.7: Straight and curved blade scissors

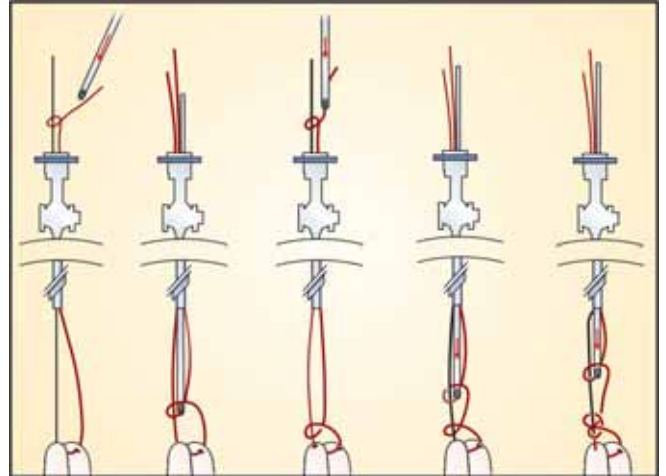


Fig. 49.9: Extracorporeal suturing

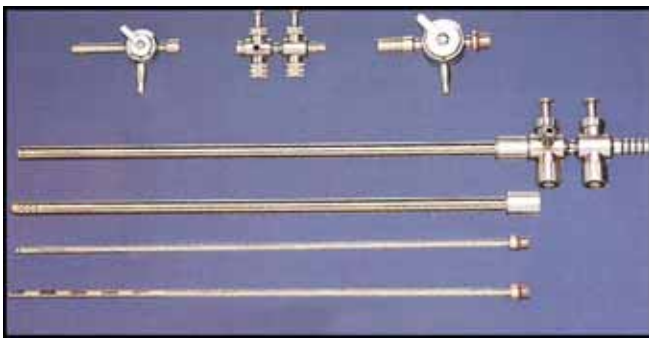


Fig. 49.8: Suction/irrigation sets

peritoneal cavity. A knot pusher is used to push multiple single throws in place much like a surgeon's finger to tighten the knot (Fig. 49.9).

**Intracorporeal suture:** After passing the suture, using classic microsurgical principles and using two needle holders, surgeons knots are tied to approximate tissues, reconstruct organs or ligate blood vessels (Fig. 49.10).

**Morcellators:** Electro-mechanical morcellators allow easy removal of larger sections of tissue (myomas, ovary, tube) quickly from existing small incisions.

**Uterine Manipulator:** It allows the uterus to be placed in desired position (anteverted, retroverted) during laparoscopy (Fig. 49.11). Some manipulators allow simultaneous chromopertubation which is preferred during tubal testing in infertility patients.

**Haemostatic Instruments**

The ability to achieve haemostasis is integral to any endoscopic procedure. Modern generators offer two

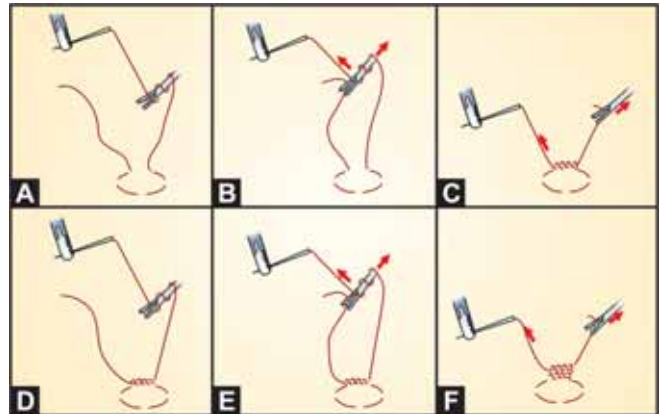


Fig. 49.10: Intracorporeal suturing

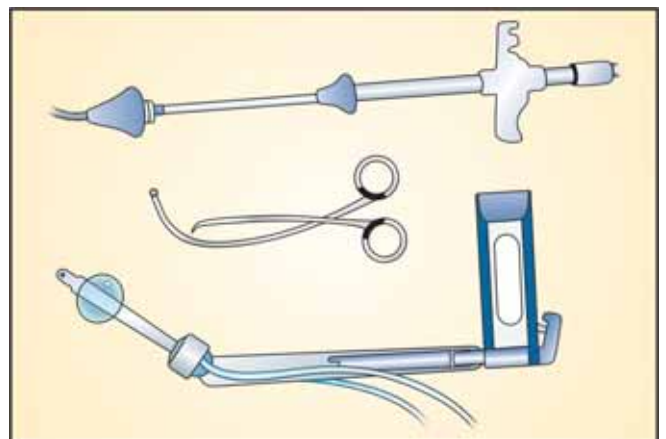


Fig. 49.11: Uterine manipulators

types of modes: Unipolar and bipolar. The generator can be connected through cables to various instruments like scissors, graspers, hooks, spatulas and bipolar forceps.

In unipolar system, current passes from the instrument to the tissue to a ground plate and then back to the generator (Fig. 49.12). Depending on the instrument used and current configuration (cutting or coagulation), various different tissue effects can be achieved including cutting, dessication, coagulation and fulguration.

The bipolar system uses two insulated jaws of instrument to carry the current. The tissue between the jaws completes the circuit, and the tissue is heated (coagulated) by the passage of current (Fig. 49.13). Bipolar forceps of various types (1 mm, 3 mm, 5 mm, Kleppinger) are available (Fig. 49.14).

### Techniques of Laparoscopy

A careful preoperative evaluation is essential before any operative procedure. Indications for the procedure must be reviewed. Contraindications to endoscopic surgery is ruled out. Informed consent should be obtained. The

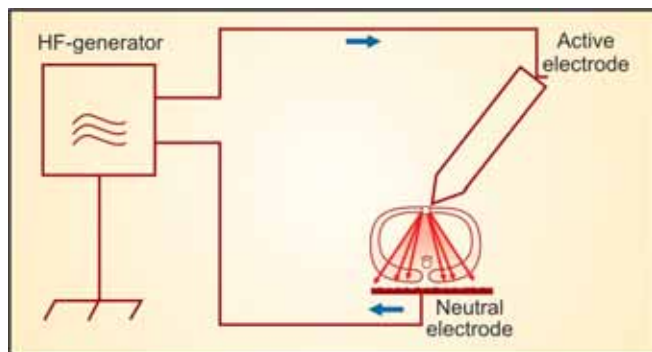


Fig. 49.12: Monopolar circuit

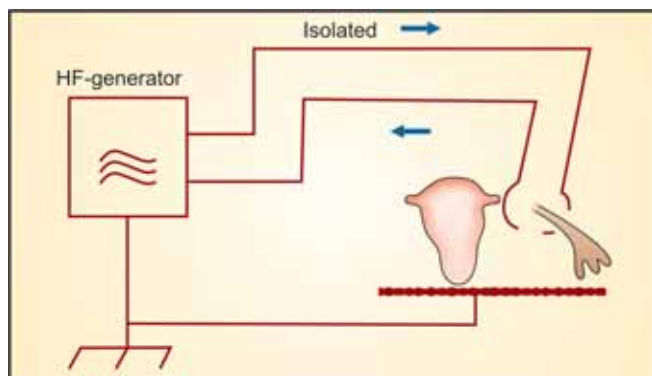


Fig. 49.13: Bipolar circuit

consent form should always contain permission for possible laparotomy.

Laparoscopy should be performed under general anaesthesia with endotracheal intubation. Intra-operative monitoring should include pulse, NIBP, SpO<sub>2</sub>, ECG, and EtCO<sub>2</sub>. The OT set-up should be designed to optimise efficiency. The OT setup is shown in the diagram (Fig. 49.15). The OT table should be capable of achieving the steep Trendelenberg position, preferably up to 20 degrees. The instruments are arranged in a mobile cart (Fig. 49.16).

**Patient Position:** The patient is placed in low dorsal lithotomy position with buttocks extended over the end of the table, allowing easier manipulation of the vaginal

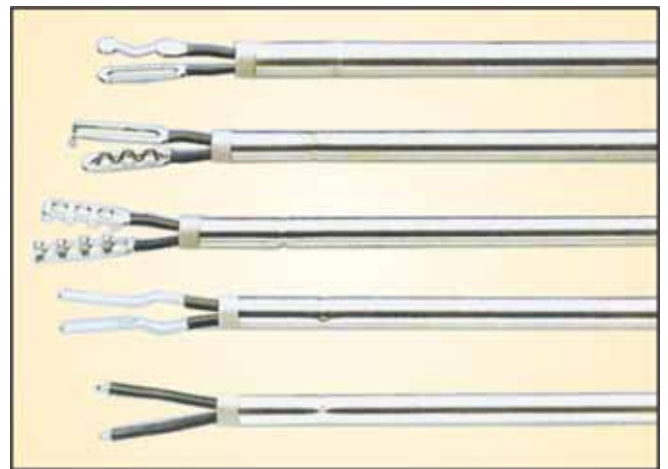


Fig. 49.14: Bipolar forceps

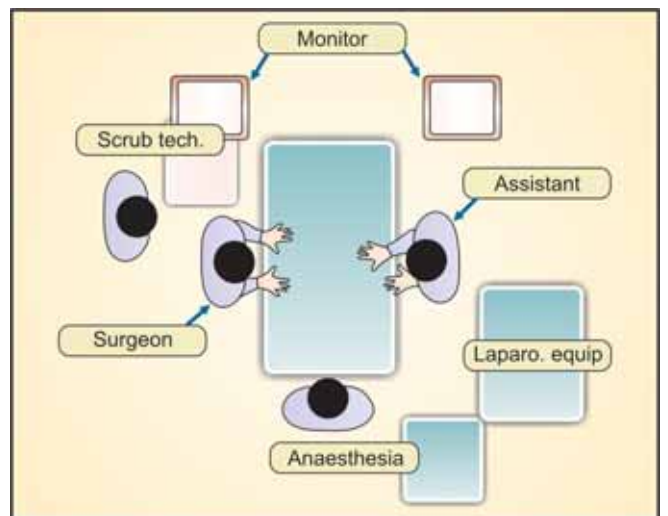


Fig. 49.15: OT setup



Fig. 49.16: Endoscopy cart

instruments (Fig. 49.17). The hips are in extension and abduction and knees slightly flexed with stirrups low, so that the thighs are in line with the abdomen, allowing easy mobility of instruments. The shoulder braces are required to prevent the patient from slipping. The arm on the surgeons side (preferably both arms) should be tucked by the side to allow greater freedom of movement for manipulation of instruments.

**Pneumoperitoneum:** It allows visualisation of abdominal and pelvic organs. CO<sub>2</sub> gas is preferred as it is rapidly absorbed and less likely to lead to gas embolism, and causes less postoperative pain. Insufflation is achieved using a Verres needle only after the patient's stomach and bladder are empty. If any doubt exists, a nasogastric tube to empty the stomach and foley's catheter to empty the bladder are used. It is widely accepted that the most dangerous moment in laparoscopic surgery is during the insertion of Verres needle and sharp primary trocar. More than 50 per cent of laparoscopic complications are attributed to problems in entry.

A vertical umbilical incision is taken, Verres needle is inserted at 45 degrees angle, directed in the midline after manually elevating the abdominal wall, and proper placement is confirmed. Adequate pneumoperitoneum is created (intra-abdominal pressure 14 mm Hg).

Tests to confirm proper Verres needle placement:

1. Initial pressure < 8 mm Hg
2. Drop water test

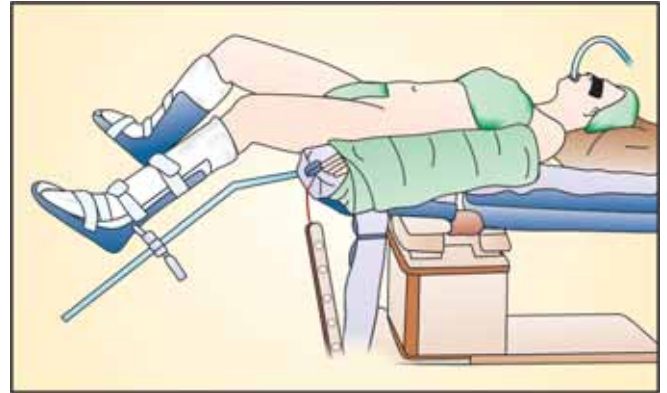


Fig. 49.17: Patient position

3. Syringe test
4. After some gas is delivered - Loss of liver dullness.  
The Verres needle is removed and the trocar is inserted aiming at the hollow of the sacrum. The laparoscope is inserted, and correct intraperitoneal placement is confirmed.

In obese patients, a more vertical angle of the needle is necessary to reach the peritoneum. Patients with previous surgical scars, or organ enlargement may require selection of an alternate site (supra-umbilical, left costal margin) depending on the area at risk.

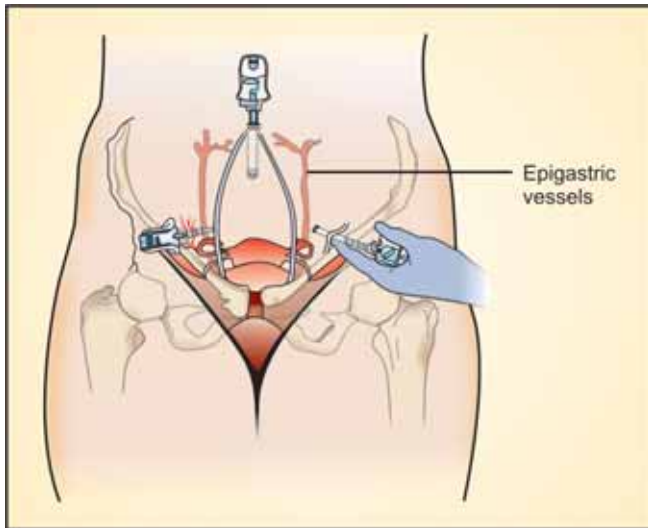
**Secondary Trocar Insertions:** Additional ports are inserted under vision lateral to the inferior epigastric vessels on both sides (Fig. 49.18). The exact position depends on the surgery undertaken, pathology, patient size, and individual preference.

### Diagnostic Laparoscopy

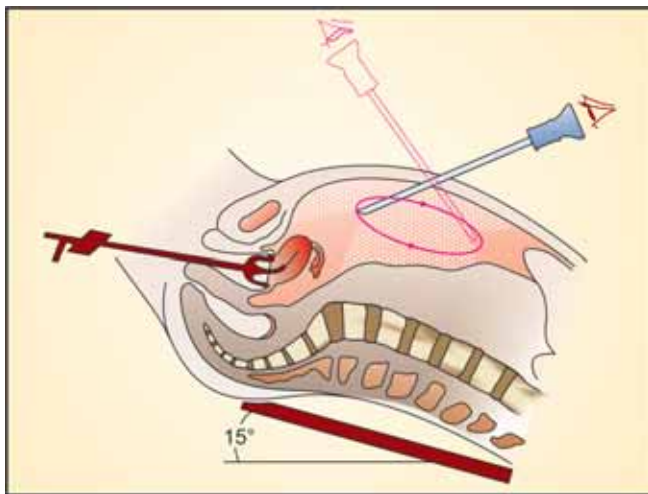
Diagnostic laparoscopy is now a basic skill which should be learnt by every gynaecologist. Direct visualisation of the abdominal and pelvic organs allows a definitive diagnosis to be made where clinical evaluation and imaging techniques have failed or are equivocal. One can proceed from diagnostic to operative laparoscopy, and with proper training be able to perform most surgical procedures.

**Inspection of the Abdominal Organs:** After insertion of the laparoscope the surgeon should perform a panoramic view of the abdomen to ensure that inadvertent damage was not caused by the Verres needle or trocar (Fig. 49.19).

The inspection is performed in a clockwise direction to visualise the caecum, appendix, ascending colon, liver,



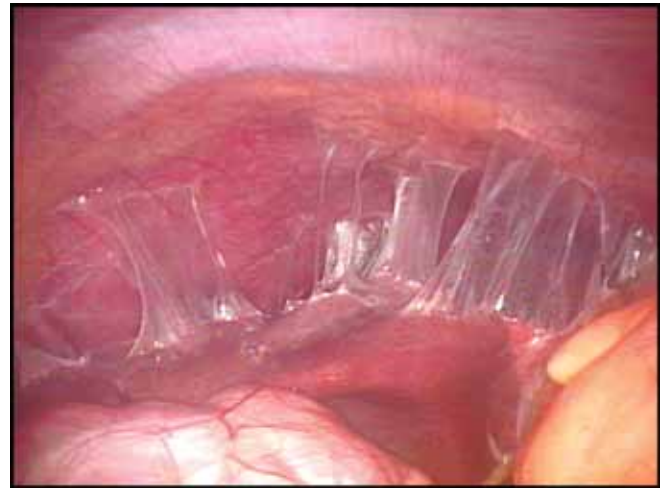
**Fig. 49.18:** Additional ports inserted under vision lateral to inferior epigastric vessels



**Fig. 49.19:** Panoramic view of the abdomen

stomach, spleen (normal not visualised, unless enlarged), and descending colon. Peri-hepatic adhesions suggestive of past peritonitis (Fitz Hugh Curtis syndrome) may be noted (Fig. 49.20). Adhesions may also be present in tuberculous abdomen or previous surgery.

**Inspection of the Pelvic Organs:** A 20 degree Trendelenburg position is given to displace the bowel and omentum in the abdomen and get a clear view of the pelvic organs. An uterine manipulator is inserted in the uterine cavity. It is impossible to perform a complete examination using a single puncture approach. A second



**Fig. 49.20:** Fitz Hugh Curtis syndrome



**Fig. 49.21:** Chromopertubation test

puncture with a probe or grasper aids full examination of the fallopian tubes, ovaries and pouch of Douglas.

It is usual to commence with the uterus and proceed in a clockwise direction visualising the anterior cul-de-sac, right adnexa, posterior cul-de-sac and left adnexa. Inspect the under surface of the ovary and ovarian fossa for adhesions or endometriosis. Chromopertubation is performed by injecting Methylene blue into the uterine cavity through the uterine cannula. Passage of dye can be observed from the fimbrial end (Fig. 49.21). Lack of tubal filling may be due to obstruction, spasm, or leakage from the cervix.

Peitubal and periovarian adhesions are better visualised by injecting 200 ml of saline in the pelvis for hydrofloatation (Fig. 49.22).





Fig. 49.22: Hydrofloatation



Fig. 49.24: PCOD drilling



Fig. 49.23: Laparoscopic TL (Yoon bands)

### Operative Laparoscopy

The various operative techniques of laparoscopic procedures are beyond the scope of this chapter. A few common operations are described here.

**Tubal Sterilisation:** A 12 mm single puncture laparocator is inserted through the umbilical cannula. Tubal bands are applied on both fallopian tubes about 1 cm from the cornual end (isthmic portion) (Fig. 49.23).

**PCOD drilling:** Two accessory ports are used. The ovary is stabilised with an atraumatic grasper. Multiple holes are drilled on the both ovarian surfaces using a high

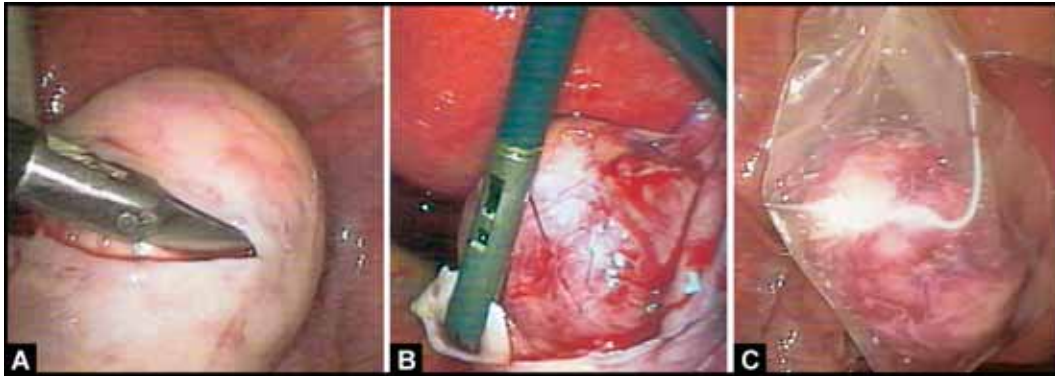
frequency monopolar needle at 40 W pure cut current (Fig. 49.24). Any bleeding can be controlled by inserting the needle in the drilled hole and using coagulation current. The ovaries are cooled using ringier lactate or saline.

**Ovarian Cystectomy:** Laparoscopic treatment is offered for benign ovarian cysts. The cortex is incised using a sharp scissor (Fig. 49.25A). Using two graspers traction is given in opposite directions, and the cyst is peeled off from the ovary cortex (Fig. 49.25B). Haemostasis is achieved using bipolar forceps. The ovarian cortex usually fall over each other and no suturing is required. The specimen is put in a endobag and retrieved from the abdomen (Fig. 49.25C).

**Ectopic pregnancy:** In an early unruptured tubal ectopic pregnancy (Fig. 49.26A) linear salpingotomy is performed (Fig. 49.26B), where preservation of tubal function is desired. The products of conception are flushed out and haemostasis achieved. The incision need not be sutured. Salpingectomy is the treatment of choice for an ectopic pregnancy when preservation of fertility is not desired (Fig. 49.26C) or when the tube is ruptured or damaged by severe adhesive disease.

**Removal of pedunculated myoma:** The pedicle is coagulated using bipolar forceps and cut using scissors or monopolar hook. The specimen is removed through the pouch of Douglas or by morcellation.

**Myomectomy (Subserous or Intramural myoma):** Dilute Pitressin (vasopressin 20 units in 100cc saline) is injected



**Figs 49.25A to C:** Laparoscopic treatment of benign ovarian cysts: (A) Cortex incised (B) Cyst dissected using two graspers (C) Cyst placed in endobag



**Figs 49.26A to C:** Laparoscopic treatment of ectopic pregnancy (A) Tubal ectopic pregnancy (B) Linear Salpingotomy (C) Salpingectomy



**Figs 49.27A to C:** Laparoscopic myomectomy: (A) Incision on myoma capsule (B) Myoma enucleated using myoma screw (C) Myoma bed sutured using intracorporeal sutures

at multiple sites in the myoma capsule. An incision is made on the serosa overlying the myoma using scissors, monopolar hook, or harmonic scalpel, and extended until it reaches the capsule (Fig. 49.27A). The myometrium retracts exposing the myoma. Giving traction on the myoma with a grasper or myoma screw, the myoma is

dissected from its capsule and removed (Fig. 49.27B). Haemostasis is achieved using bipolar forceps. Myometrium is repaired in two or three layers using extracorporeal or intracorporeal sutures (Fig. 49.27C). The specimen is removed through the pouch of Douglas or by morcellation.

**Hysterectomy:** No consensus exists as to the advantage of laparoscopic hysterectomy over vaginal hysterectomy. In selected cases laparoscopic approach is superior to abdominal hysterectomy. In laparoscopic hysterectomy (LH) all the uterine pedicles are done laparoscopically (Fig. 49.28B), whereas in laparoscopic assisted vaginal hysterectomy (LAVH), the upper pedicles are done laparoscopically and the uterine arteries and uterosacral ligaments are secured through the vaginal route (Fig. 49.28A).

### Complications of Laparoscopy

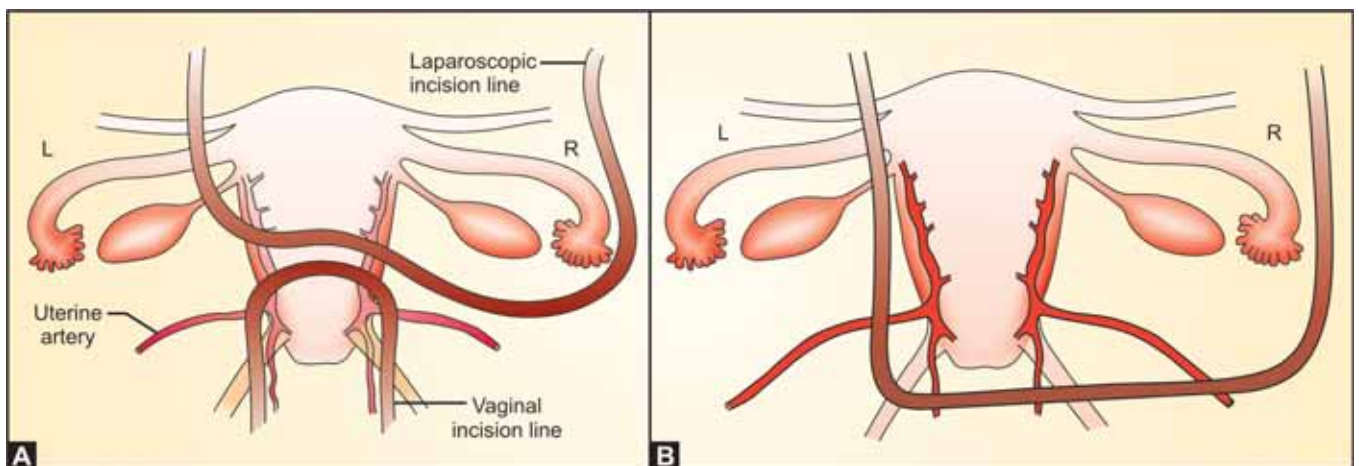
Complications occur with laparoscopic procedures as with all surgical procedures. Surgical experience and adherence to proper technique are essential to prevent complications.

**Anaesthetic complications:** Some features of laparoscopic surgery predispose to specific anaesthetic complications. The use of a steep Trendelenburg position and the distension of the abdomen may both reduce excursion of the diaphragm. Carbon dioxide (CO<sub>2</sub>) can be absorbed particularly during prolonged operations. Monitoring by pulse oximetry, the use of endotracheal intubation and positive pressure assisted ventilation reduce the risk of hypercarbia to a minimum. If arrhythmia occurs, return to supine position, reduce intra-abdominal pressure and stop surgery till parameters are stabilised.

**Patient Positioning:** While not unique to laparoscopic surgery, nerve injuries are more common after long prolonged procedures. Hyperextension of the arm can cause brachial plexus traction and damage. Femoral neuropathy can result in very thin patients when the hips and knees are flexed. Peroneal nerve entrapment is possible when the knee is pressed on some object (lithotomy rods).

**Pneumoperitoneum:** Extraperitoneal insufflation occurs when the Verres needle fails to enter the peritoneal cavity. When the incorrect placement is recognised, the CO<sub>2</sub> gas is allowed to escape and the needle reinserted. The emphysema resolves spontaneously. Emphysema of the omentum is a self-limited problem but may make visualisation of the abdominopelvic structures difficult. A penetrating injury to blood vessel may be unrecognised at the time of insufflation and lead to gas embolism and death.

**Vascular Injury:** Verres needle or trocar may traumatise omental or mesenteric blood vessels or any major abdominal or pelvic arteries or veins. Thin, small patients are at particular risk. Major vessel injury requires immediate laparotomy, vascular repair and transfusion. Elevated abdominal pressures due to pneumoperitoneum may tamponade vessels and retroperitoneal injury may not be evident intraoperatively. Once the gas is released and intra-abdominal pressure reduced, vessels may bleed and cause hypovolemic shock.



**Figs 49.28A and B:** (A) LAVH with laparoscopic mobilisation of adnexa and vaginal securing of uterine arteries and uterosacral and cardinal ligaments. (B) Total Laparoscopic Hysterectomy (TLH). This stage involves the complete mobilisation of the uterus laparoscopically including uterosacral and cardinal ligaments combined with laparoscopic opening of anterior and posterior cul-de-sac. Vagina vault closed laparoscopically or vaginally.

Epigastric vessels can be injured during placement of accessory ports. Direct laparoscopic visualisation of inferior epigastric vessels and insertion of trocar lateral to the edge of rectus muscle (8 cm lateral to midline) will decrease this risk.

**Bowel Injury:** Gastric injury is known if the stomach is distended after intubation. If intubation is difficult, gastric decompression using a naso-gastric tube is advisable prior to Verres needle insertion. Injury to bowel is likely during Verres or trocar insertion in patients with previous abdominal surgery or pelvic adhesive disease (Fig. 49.29). Bowel injury requires immediate repair done laparoscopically, if the surgeon is experienced or by laparotomy.

Thermal injury can be caused by direct contact of electrical or thermal energy with an organ or tissue. With electrical injury, the full extent of damage may not be obvious immediately. Post operative paralytic ileus is less common than at laparotomy, unless extensive bowel dissection is performed.

**Bladder injury:** A full bladder can be damaged during Verres or trocar insertion. All patients should have bladder drained after anaesthesia is induced. If the procedure is expected to take longer than 30 minutes, a catheter is inserted for continuous drainage. Patients with previous caesarean section are at high risk of bladder injury during laparoscopic hysterectomy. Bladder injuries should be sutured and bladder drained continuously for 4-5 days.

**Ureteral Injury:** Ureters may be injured during laparoscopic hysterectomy during coagulation of the infundibulo-pelvic ligaments or near the uterine vessels. Ureters are particularly susceptible to injury when adhesions or endometriosis involves the pelvic sidewall. Ureteral stents may be helpful in locating the ureters if the anatomy is severely distorted. Injuries should be repaired by a urologist depending on the location and type of the injury.

**Trocar hernias:** Although rare, herniation of bowel and incarceration is seen in ports larger than 10 mm. Use of larger ports mandate fascial closure to prevent hernias.

**Incidence of complications:** In a large Finnish study, among 32,205 gynaecologic laparoscopies, 130 major complications were noted. The total complication rate was 4.0 per 1000 procedures: 0.6 per 1000 in diagnostic laparoscopies, 0.5 per 1000 in sterilisation, and 12.6 per 1000 in operative laparoscopies. Intestinal injuries were reported in 0.7 per 1000, incisional hernias in 0.3 per 1000, urinary tract injuries in 2.5 per 1000, major vascular injuries in 0.1 per 1000, and other injuries in 0.5 per 1000 gynaecologic laparoscopic procedures. Hysterectomy was the operation performed in 75 per cent (88 of 118) of the instances of major complications during operative laparoscopy. The mortality is approximately 3/100,000.

## HYSTEROSCOPY

Hysteroscopy is the inspection of the uterine cavity by endoscopy. It allows for the diagnosis of intrauterine pathology and serves as a method for surgical intervention (operative hysteroscopy). Hysteroscopic procedures were first described by Pantaleoni in 1869. Although it was one of the first endoscopic procedures to be performed, it took over 100 years for refinements in instruments, distension media, electronic hysteroscopes before hysteroscopy was accepted as a modality of treatment for intrauterine pathology.

### Advantages

Operative hysteroscopy has in many ways superseded laparoscopy in meeting the minimal invasive criteria. It uses the endocervical canal, the body's natural passage, to gain entry into uterine cavity. Non-hysteroscopic techniques to treat intrauterine septa and adhesions are obsolete. Submucous myoma removal no longer requires a hysterotomy. Cornual and interstitial tubal obstruction is also managed hysteroscopically. Endometrial ablation

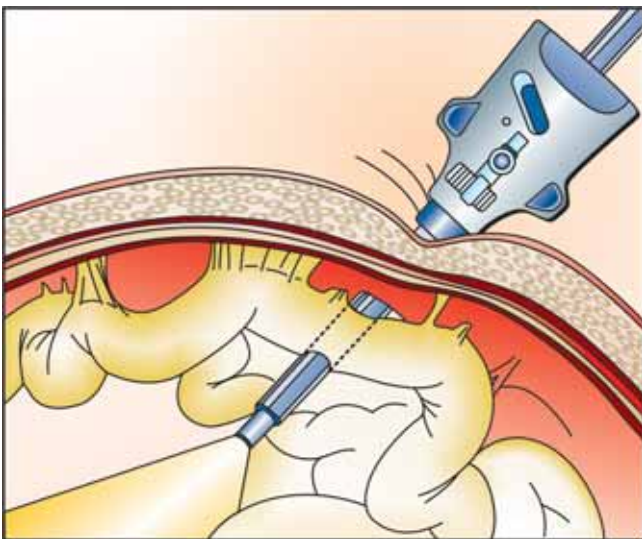


Fig. 49.29: Bowel injury during trocar insertion in a patient with bowel adhesions

or resection is considered an acceptable alternative to hysterectomy for treatment of abnormal uterine bleeding.

Since the 1990s hysteroscopy has finally found its proper niche, and every practicing gynaecologist must learn the skills of hysteroscopy.

### Disadvantages

If used properly there are no disadvantages of this procedure.

### Indications

**Diagnostic hysteroscopy** is indicated in evaluation of the uterine cavity in patients with:

1. Infertility (to evaluate abnormal hysterosalpingograms – filling defects, adhesions)
2. Abnormal Uterine Bleeding (menorrhagia, irregular bleeding, postmenopausal bleeding)
3. Müllerian abnormalities (in patients with recurrent pregnancy loss – septate uterus, “T” shaped uterus)
4. Lost or misplaced IUD's

### Indications of Operative Hysteroscopy

1. Targeted endometrial biopsy (suspected tuberculosis, endometrial carcinoma)
2. Removal of polyps, sub-mucous myoma
3. Adhesiolysis
4. Metroplasty (incision of uterine septum)
5. Removal of misplaced IUD or foreign body
6. Tubal cannulation in cornual or interstitial block
7. Treatment of DUB (Endometrial ablation, TCRE)
8. Sterilisation (electrocoagulation or tubal plugs to block the tubes)



Fig. 49.30: Hysteroscope with diagnostic sheath

### Contraindications

1. Recent or active pelvic inflammatory disease
2. Acute cervico-vaginal infection
3. Active uterine bleeding (causing poor visibility)
4. Current intrauterine pregnancy

### Equipment For Hysteroscopy

**Telescope and Sheath:** The hysteroscope system is comprised of a rigid telescope that is used together with an outer sheath for instillation of the distension media. Telescopes of different diameters (2-4 mm) and variety of viewing capability (0°, 12°, 30°, 70°) are available.

The most popular hysteroscope is a 4 mm telescope with a 5.5 mm outer sheath for diagnostic hysteroscopy (Fig. 49.30). A 6.5 mm double channel continuous flow sheath is available and is useful when the uterine cavity is bleeding. The same telescope can be used with operative hysteroscopy sheath and resectoscope.

**Operative Hysteroscope:** The internal lumen of the sheath must be of adequate size to allow passage of the telescope and an operative instrument e.g. scissors, biopsy forceps, catheters and coagulation electrodes (Figs. 49.31A and B). The external sheath diameter ranges



Fig. 49.31A: Operative hysteroscope with instrument through the operative channel

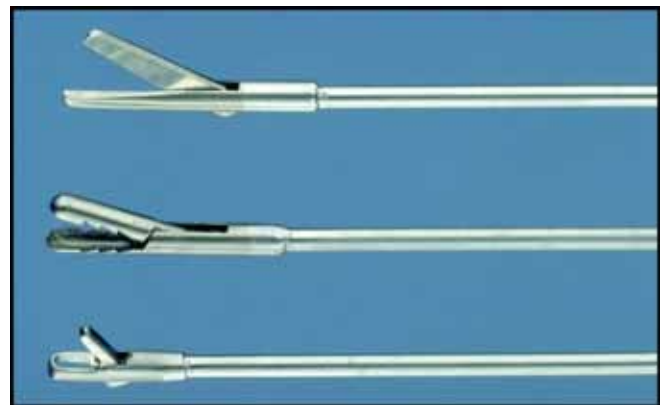


Fig. 49.31B: Operative hysteroscopic instruments

between 3.5-7 mm to allow for passage of telescope, operative instruments and liquid distension media.

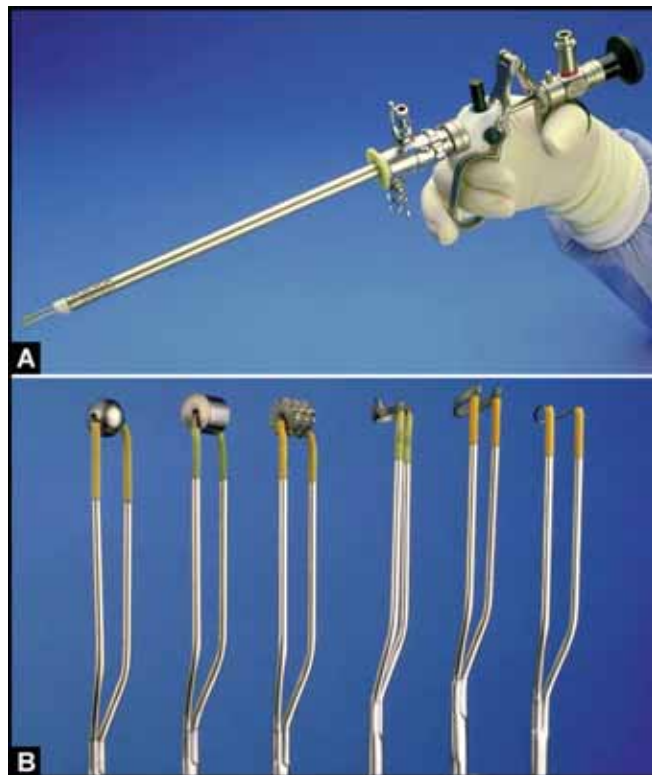
**Resectoscope:** It has been used by urologists for many years. Since 1990 it has been used in a modified form by gynaecologists to perform operative procedures such as excision of submucous myomas, polypectomy, division of uterine septa and endometrial ablation or resection. It consists of a telescope, continuous inflow-outflow system and a working element on which various electrodes can be mounted (ball, loop, knife, barrel) to deliver monopolar electrosurgical energy and perform cutting, coagulation, vaporisation in the uterine cavity (Figs 49.32A and B).

### Ancilliary Equipment

The light source, CCD camera, recording device, and electrosurgical unit are same as used in laparoscopy.

### Distension Media

Hysteroscopy provided little information until safe, effective distension was developed. Uterine cavity is a



**Figs 49.32A and B:** (A) Resectoscope  
(B) Accessories with resectoscope

potential space. Distension media enable to separate the uterine walls and obtain a panoramic view. Liquid distension media when used in continuous flow flush out the blood, blood clots and debris formed during operative hysteroscopy and resectoscopy.

The media are of two types:

#### **Gaseous:**

**Carbon-dioxide (CO<sub>2</sub>)** is used for diagnostic hysteroscopy. It is inexpensive, non-messy, readily available and has refractive index same as air, giving a clear view. In presence of blood or mucus it can cause a distorted view. It needs an expensive electronic hysteroscopic insufflator for safe delivery of gas at correct flow rate (30-60 ml/min) and pressure (100-120 mmHg range).

#### **Liquid:**

a. **Saline and Ringers lactate** are physiologic, iso-osmolar and isotonic. Until very recently, they were used only during diagnostic hysteroscopy or operative hysteroscopy without the use of electrosurgical systems, as the presence of electrolytes precluded the use of these solutions during monopolar electrosurgical operations.

The recent development of bipolar intrauterine surgery, explicitly designed to avoid use of electrolyte free solutions, has encouraged the use of normal saline solution for hysteroscopic surgery.

b. **Glycine** is a simple amino acid that is mixed with water as a 1.5 per cent solution. It is readily available, cheap, and provides fairly good visibility. Like all nonviscous distension media it is miscible with blood and requires continuous-flow irrigation. It is a non-electrolytic solution and can be used during monopolar electrosurgery. As it is hypo-osmolar and hypotonic, if it intravasates into the vascular tree in significant amounts, it can produce profound hyponatraemia, hypervolaemia, with pulmonary oedema, cerebral oedema, heart failure and death.

### Fluid Delivery Systems

The systems used to control flow and pressure during hysteroscopy are as follows:

**Pressure cuff** (Fig. 49.33): These devices, similar to a sphygmomanometer, are inflated around the bag, exerting pressure on it.

**Electronic Suction and Irrigation Pump** (Fig. 49.34): Hamou Endomat is a automatically controlled suction and



Fig. 49.33: Pressure cuff

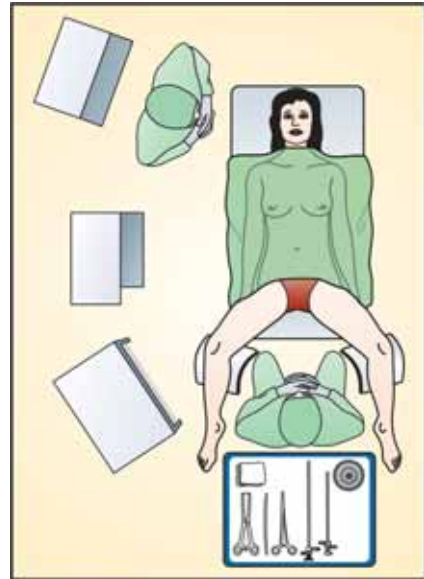


Fig. 49.35: Hysteroscopy setup



Fig. 49.34: Hamou endomat

irrigation pump which can maintain a clear field of view and constant uterine distension during hysteroscopic surgery.

### Technique of Hysteroscopy

Patients can be scheduled for diagnostic hysteroscopy after obtaining a detailed patient history, performing a physical examination, discussing choice of anaesthesia, and obtaining informed consent. Hysteroscopy should be done in the post-menstrual period as the endometrium is thin which facilitates intra-cavity viewing, bleeding is minimal and pregnancy is ruled out.

Although hysteroscopy in the office setup can be done without anaesthesia or paracervical block, in most cases we prefer to do it under general anaesthesia. If combined with laparoscopy, a general anaesthesia with tracheal intubation is preferred.

**Position:** Patient is placed in standard lithotomy position with legs apart to obtain vaginal access (Fig. 49.35).

### Diagnostic Hysteroscopy

**Procedure:** Cervix is held with vulsellum and dilated using Hegars dilator. The hysteroscope is inserted in the cervical canal and advanced under vision till it enters the uterine cavity. A systematic evaluation of the cavity is done observing the fundus, tubal ostia, anterior and posterior wall and cervix canal (Fig. 49.36). Any irregularity in the cavity, adhesions (Fig. 49.37), polyps (Fig. 49.38) or myomas (Fig. 49.39) and uterine septum (Fig. 49.40) are noted.

Inadequate visualisation is usually due to (1) overdilatation of cervix causing leakage of distension media and inadequate distension (2) excessive bleeding (3) uterine perforation.

### Operative Hysteroscopy

Hysteroscopic biopsy forceps can be used for targeted biopsy in patients with suspected tuberculosis or



Fig. 49.36: Hysteroscopy – normal cavity



Fig. 49.38: Hysteroscopy – polyp

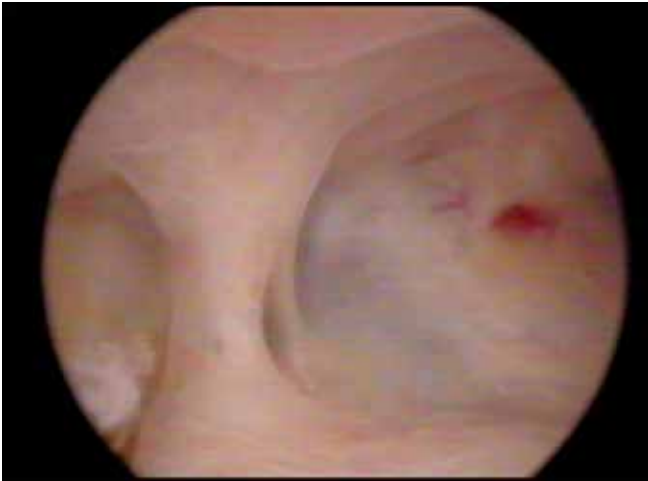


Fig. 49.37: Hysteroscopy – adhesions



Fig. 49.39: Hysteroscopy – fibroid

endometrial carcinoma. Hysteroscopic scissors is used to cut adhesions and uterine septum. A 6F catheter can be passed through the operative channel of the operative sheath and tubal ostia cannulated.

Resectoscope loop can be used to shave sub-mucous myomas and perform endometrial resection. Roller ball is used to perform endometrial ablation and knife can be used to cut dense adhesions and thick uterine septae.

### Complications of Hysteroscopy

Complications may occur in diagnostic or operative hysteroscopy.

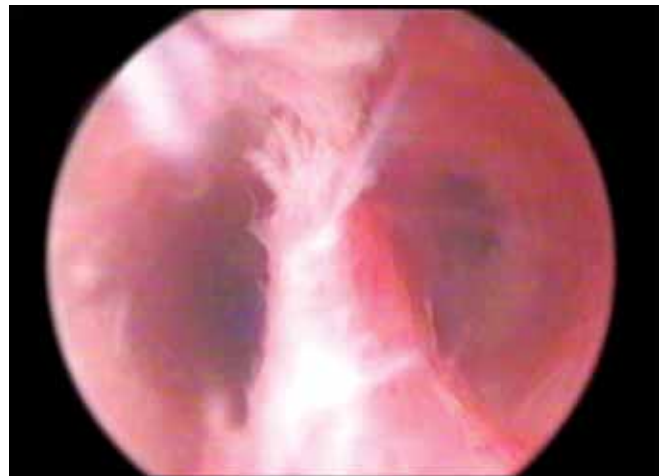


Fig. 49.40: Hysteroscopy – septum



### *Anaesthetic Complications*

The risks to the patient from the anaesthetic are similar to those from any other operation.

### *Patient Position*

Incorrect positioning of the patient may result in:

1. *Nerve Injuries:* Brachial plexus injury may result from incorrectly placed shoulder restraints or from leaving the patient's arm abducted on an arm board. Pressure on the peroneal nerve by lithotomy stirrups may result in paraesthesia and foot drop.
2. *Damage to soft tissue:* The surgeon should ensure that no part of the patient is in contact with metal parts of the table because these can act as return plates for electrical energy and burns can occur at the point of contact.
3. *Deep venous thrombosis:* It can result from prolonged compression of the calves by the leg supports. The surgeon should ensure that the type of support is appropriate and well padded. If DVT is suspected, the advice of a physician should be sought and appropriate anticoagulant therapy instituted.

### *Distension Media*

Complications produced by the distension media are specific to hysteroscopic surgery. It is essential that all the operating room staff are cognisant of the side effects of the distension media and that responsibility for accountability of fluid media is placed on a designated member of staff.

*Carbon dioxide:* Cardiac arrhythmia and rarely gas embolism may occur with diagnostic hysteroscopy.

### *Liquids*

**Saline** may be used in diagnostic hysteroscopy but only non-electrolytic fluids should be used with electro-surgery because of the risk of producing burns to other organs. All low molecular weight fluids may produce fluid overload. Accountability of fluid input and output is mandatory in any hysteroscopic procedure. The severity and management of fluid overload depends on the nature of the medium in use.

Saline overload produces a simple hypervolaemic state which may be treated by insertion of a central venous line, administration of a diuretic, oxygen and, if necessary, cardiac stimulants.

**Glycine** overload may produce nausea and vertigo, hyponatraemia, transient hypertension followed by hypotension associated with confusion and disorientation. Excessive overload may produce elevated blood ammonium levels leading to encephalopathy and, rarely, death. Hyponatraemia should be treated with administration of diuretics and hypertonic saline solution combined with monitoring of serum electrolyte levels until normality has been restored. Encephalopathy requires haemodialysis to be performed.

### *Surgical Complications*

Complications of surgery may arise during the operation or be delayed. Intra-operative complications include uterine perforation and haemorrhage.

Simple perforation may be made with a cervical dilator, with the hysteroscope or non-electrical instruments. Simple perforation rarely causes any further damage and may be treated conservatively by observation and appropriate broad spectrum antibiotics. Laparoscopy may be considered to exclude bleeding.

Complex perforation may be made with electrical instruments and are associated with thermal injury to adjacent structures including bowel or large vessels. If the perforation has been caused by an electrosurgical instrument laparoscopic examination or laparotomy to exclude bowel or vascular injury is mandatory.

Delayed complications include infection, discharge and adhesion formation.

### *Failure of Resolution of the Presenting Symptoms*

The procedure may fail to cure the presenting symptoms. This may be because of poor patient selection or failure of the surgery.

Endometrial ablation produces amenorrhoea in about 30 per cent of cases and satisfactory improvement in about another 50 per cent. Ten per cent will require further surgery, which may be a repeat ablation or hysterectomy.

Adhesiolysis for Asherman's syndrome is only curative in about 30-40 per cent of cases.

### *Incidence of Complications*

The complication rate in diagnostic hysteroscopy is low and was estimated by Lindemann (1989) to be 0.012 per cent. Complications from operative hysteroscopy are more common and potentially more serious.

# CHAPTER 50

## Contraception

General Considerations	784
Indications	786
Methods	787

### GENERAL CONSIDERATION

Contraception is the prevention of conception by methods other than abstinence from coitus. It is useful to limit the size and age structure of a family is birth control in family planning. Contraceptive advice is a component of good preventive health care. The role of clinician is to provide the education necessary for the patient to make proper choices "Cafeteria approach". An emphasis on safety and benefits can have a major impact on contraceptive decisions. By preventing high risk and unwanted pregnancies it decreases maternal deaths. Contraception provides a better quality of life by helping families to use their resources for food, clothing, housing, schooling and medical care.

### Epidemiology

The national survey of family growth is conducted by the national centre for health statistics of the centres for disease control and prevention. Figure 50.1 shows the graph of the increase of world population which is expected to touch 11.5 billion by 2150.

- The per cent of married couples using sterilisation as a method of contraception more than doubled from 1972 to 1988 and has remained stable since then.
- The use of oral contraception reached a peak in 1992 and then decreased in 1995, especially among Hispanic and black Americans.
- Among newer married women, oral contraception has been the leading method of birth control, but from 1988 to 1995, oral contraceptive use decreased in women younger than 25 and rose among women aged 30-44. This may be due to availability and use of implants and injectable methods.
- The recent increase in overall contraceptive use is due to the increase in condoms use, which rose from 5.1 million in 1988 (15%) to 7.9 million in 1995 (20%). This increase occurred in all races and ethnic groups. These changes reflect the concern regarding sexually transmitted disease including HIV.
- In 1982, 56 per cent of US women, 15-44 years of age, were using contraception and this increased in 1995 to 64 per cent.
- The number of reproductive age group women using IUCD has decreased from 2 million in 1982 to only 0.3 million in 1995 in US.

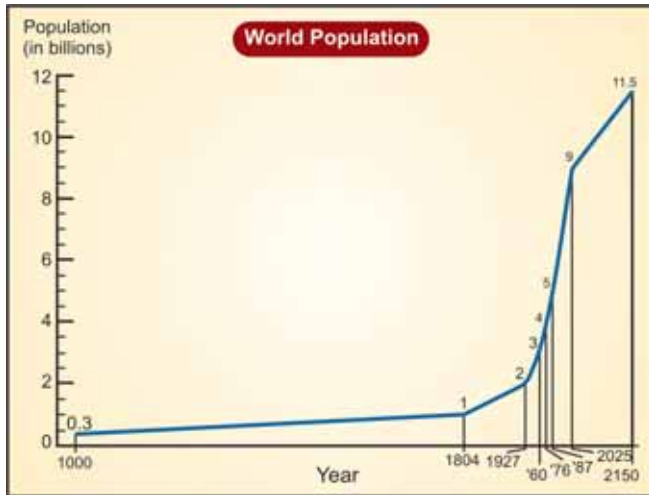


Fig. 50.1: Graph of increase of World Population by 2150

- The oral contraceptive is the most popular method among teenagers.
- During the years of maximal fertility, oral contraceptives are the most common method peaking at age 20-24. The use of condom is the second most widely used method of reversible contraception, rising from 15 to 20 per cent in 1995.

### The Impact of Contraception Throughout World

- World population is expected to stabilise at between 11 and 12 billion around 2150, with a fertility rate of 2.1 children per woman. Approximately 95 per cent of the growth will occur in developing countries so that by 2100, 13 per cent of the population will live in developed countries, a decrease from the current 25 per cent. Only Europe has achieved a stable population till now.
- Throughout the world, 45 per cent of married women of reproductive age practice contraception while 69 per cent in East Asia and only 11 per cent in Africa.
- Female sterilisation and the IUCD are most popular in developing countries whereas oral contraceptives and condoms are most popular in developed countries.
- Nearly 76 per cent of the world's population living in developing countries account for 85 per cent of all births, 95 per cent of all infant and childhood deaths and 99 per cent of all maternal deaths.

- The health risks associated with pregnancy and childbirth in the developing world are far greater than risks secondary to the use of modern contraception.
- The interaction between clinician and patient for the purpose of contraception also provide opportunity to control sexually transmitted diseases (STD's). If an infection is symptomatic, it can be treated during the same visit in which contraception is requested.
- The impact of contraception can be measured in terms of both morbidity and mortality.

### Efficacy of Contraception

Contraceptive efficacy is generally assessed by measuring the number of unplanned pregnancies that occur during a specified period of exposure and use of a contraceptive method. The two methods that have been used to measure contraceptive efficacy are the pearl index and life table analysis.

#### The Pearl Index

The pearl index is defined as the number of failures per 100 women years of exposure multiplied by 1200 if the denominator consists of months or by 1300 if the denominator consists of cycles.

$$\text{Pearl index} = \frac{\text{Number of pregnancies}}{\text{Total months or cycle of exposure from the onset of method}} \times 1200$$

With most methods of contraception, failure rates decline with duration of use. Pearl index is usually based on a specific exposure (usually one year) and therefore fails to accurately compare methods at various duration of exposure. This limitation is overcome by using the method of life table analysis.

#### Life Table Analysis

Life table analysis calculates a failure rate per month of use. A cumulative failure rate can then compare methods for any specific length of exposure. Women who leave a study for any reason other than unintended pregnancy are removed from the analysis, contributing their exposure until the time of the exit.

Contraceptive failure do occur and for many reasons. Thus method effectiveness and use effectiveness have been used to designate efficacy with correct and incorrect

use of a method. It is less confusing to simply compare the very best performance (the lowest expected failure rate) with the usual experience (typical failure rate). The lowest expected failure rates are determined in clinical trials.

### Indications for Contraception

1. **Limiting the Population:** This suits the economic interest of the community. Population control is now a pressing problem throughout the world. This is because the advancements in medicine and civilisation has resulted in death control. The world population has doubled in the last 50 years, increasing from approximately 8 million in 8000 BC, the world population is expected to be 11 to 12 billion around 2150. India and China have both crossed the one billion mark. The factors concerned in birth rate, family size and population increase include climate, nutrition, fertility, age of marriage, custom and fashion, desire for sons, law of inheritance, religion, politics warfare, education and the infant death rate. It is said that a decreasing infant death rate, which makes a mother with only a small family feel more secure, inevitably results in a falling birth rate. This is not so far manifest in all countries, which means there is an urgent need for a widespread distribution of contraceptive devices and instructions in their use. To ensure a zero population growth rate the average number of children per family should not exceed 2.2.
  2. **Early Marriage:** It is often wise for a couple to practise contraception during the early part of marriage but this does not apply when the partners are no longer young, when they are already well adjusted by a long engagement or when their circumstances are propitious. Indeed, many young brides decide to have a limited number of children as soon as is reasonable with the object of completing their childbearing within a few years and returning to their work of profession as soon as their maternal responsibilities allow.
  3. **Birth Spacing:** If a woman has children too frequently, she has no time to recover from one, before she is faced with another one. She is then prone to anaemia, muscle and ligamentary strains, postural defects and nervous exhaustions. She becomes unable to cope with her domestic responsibilities, allows the home to become dirty and cheerless, neglects her children and as a result, the whole family suffers.
  4. **Previous Obstetrical Complications:** Recurrent pregnancy hypertension, repeat caesarean section, repaired obstetrical injuries such as vesicovaginal fistula and a previous operation for prolapse can justify the avoidance or deferment of further childbearing.
  5. Family limitation
  6. **Chronic systemic diseases in the woman:** These include nephritis, hypertension, cardiac disease, pulmonary insufficiency, psychoses, neurosis, blood disorders and any disease which makes a woman less able to withstand the strain of pregnancy and labour, or which makes her unfit to cope with the rearing of another child.
  7. Temporary ill health in either partner.
  8. **Later years of marriage:** When the family is complete contra caption can be used in place of permanent sterilisation.
  9. **On request:** There is much to be said for giving contraceptive advice to any girl or woman or man who asks for it, irrespective of their circumstances. If they have decided to be sexually active and if consultation makes it clear that they appreciate the implications, they should be protected from having an unwanted child or an induced abortion.
  10. **Emergency contraception:** Occasionally a couple may have an unprotected coitus or there may be a problem with the contraceptive method used e.g. condom rupture, displaced IUCD or irregular hormonal contraception, an emergency contraception may be required. However it is not a substitute for regular contraceptive method.
- Various contraceptive methods available are:
- I. **Reversible Methods**
    - A. Natural family planning method
    - B. Barrier methods
    - C. Intrauterine contraceptive devices (IUCD's)
    - D. Steroidal contraception
      - Combined hormonal contraception
      - Progestogen only contraception
    - E. Non-steroidal contraception
    - F. Post-coital or emergency contraception
    - G. Others
  - II. **Permanent Methods**
    - A. Female – Tubal ligation
    - B. Male – Vasectomy

## A. Natural Family Planning Method

### Fertility Awareness Based Method or Traditional Methods

This method refers to methods for planning and preventing pregnancies by observation of the naturally occurring signs and symptoms of the fertile and infertile phases of menstrual cycle, with the avoidance of sexual intercourse during the fertile phase (WHO 1982).

Fertile phase is calculated by:

1. Rhythm method or safe period or calendar method (Fig. 50.2).

It is based on the fact that most women ovulate approximately two weeks or 14 days before each menstruation, regardless of the length of their menstrual cycle. Couple avoids intercourse during fertile period.

The woman records the number of days in each menstrual cycle for at least 6 months. The first day of menstrual cycle bleeding is always counted as day 1. The woman subtracts 18 from the length of her shortest recorded cycle. This tells her the estimated first day of her fertile period. Then she subtracts 11 days from the length of her longest recorded cycle. This tells her the

last day of her fertile period. The couple avoids sex or uses a barrier method or withdrawal during the fertile period.

e.g. If her recorded cycles vary from 26 to 32 days then

$$26 - 18 = 8\text{th day}$$

start avoiding unprotected sex on day 8

$$32 - 11 = 21\text{st day}$$

Continue avoiding unprotected sex till day 21 of cycle.

**Disadvantage:** woman with irregular cycles can not use this method.

2. Cervical mucus method or 'BILLING' method change
  - Change in the odour, amount and touch of the cervical mucus discharge are recognised.
  - The secretions have a peak day, when they are most slippery, stretchy and wet.
  - The couple avoids sex, uses withdrawal or barrier methods until 4 days after the peak day.
3. Basal body temperature method
  - Basal body temperature is the temperature of body at rest.

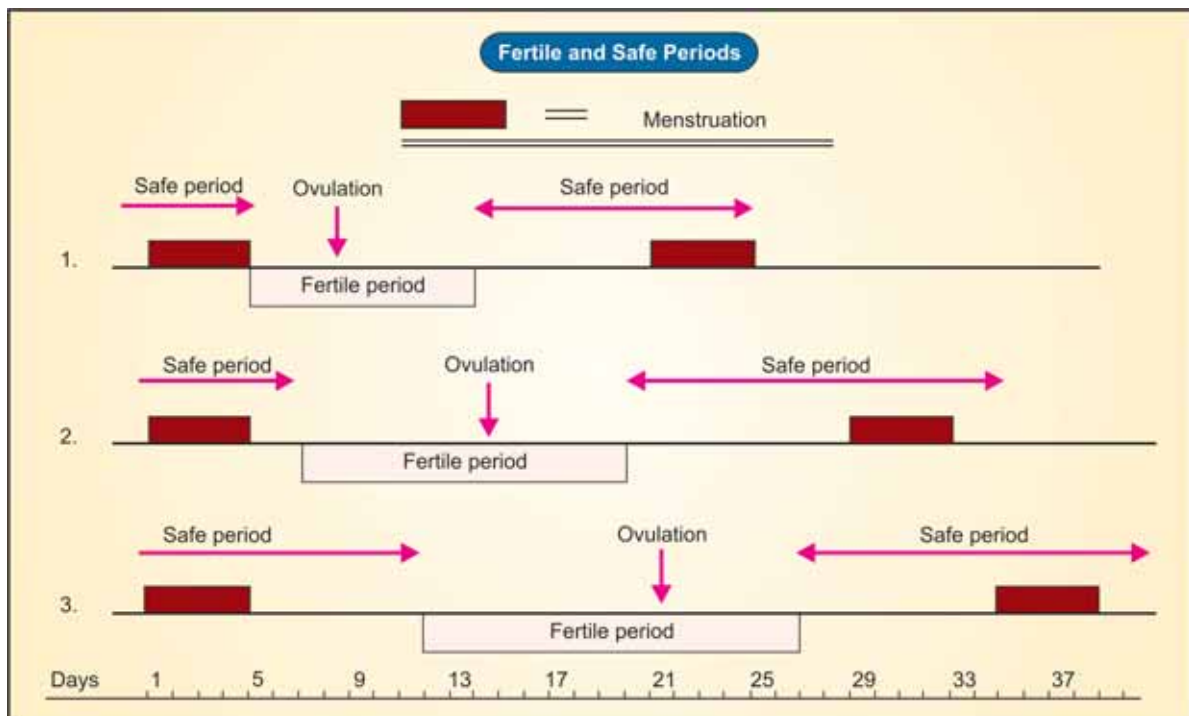


Fig. 50.2: The fertile and 'safe' periods during a (1) 21-day cycle, (2) 28-day cycle, and (3) 35-day cycle

- It is taken by the patient in the bed, after getting up from the sleep, without taking anything by mouth.
- The BBT rises from a lower level to a higher level of at least 0.5°C or 1°F. This occurs shortly after ovulation. It remains at a higher level until she begins to menstruate again.
- It can only be used to tell when the late infertile phase begins but not the end of it.
- The couple avoids sex from first day of menses until the woman's temperature has risen above her regular temperature and stayed up for 3 full days.

4. Sympto-thermal Method (Fig. 50.3)

- This is a combined method in which woman identify fertile and infertile days by combining BBT, cervical mucus changes and other signs and symptoms of ovulation like abdominal pain, breast tenderness, etc.
- **Failure rate of natural family planning method is 18-25 pregnancies** per HWY. This is because the time of ovulation varies even in regularly menstruating women.

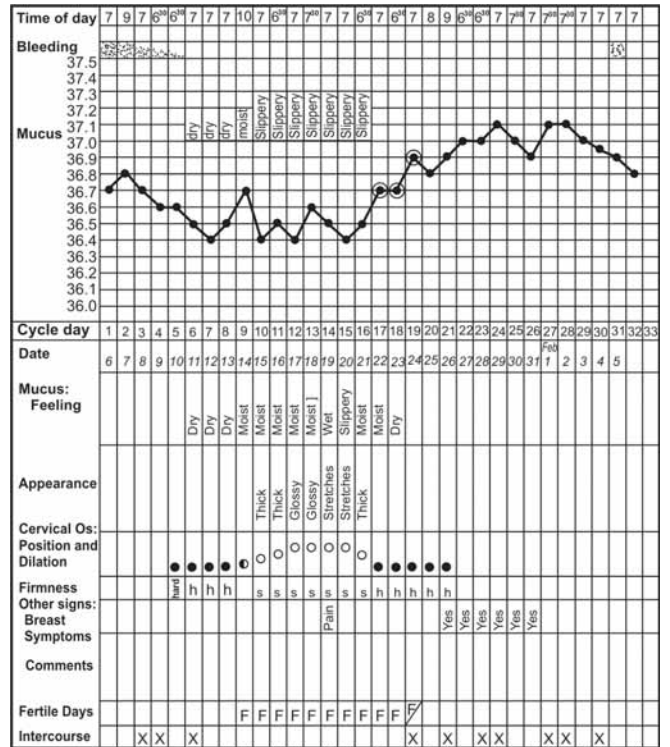


Fig. 50.3: Sympto – Thermal Methods

B. Lactational Amenorrhoea Method (LAM)

- This method is based on physiology of breast-feeding.
- If a breast feeding woman meets three criteria, her risk of pregnancy in first six months is 2 per cent HWY.
  - a. Lactational amenorrhoea
  - b. Exclusive breast feeding or nearly full breast feeding, day and night on demand of baby.
  - c. Less than six months postpartum
- Rule of 3's for postpartum initiation of contraception i.e. full breast-feeding, begin in 3rd postpartum month: and partial or no breast feeding, begin in 3rd postpartum week.
- Elevated levels of prolactin inhibit the pulsatile release of GnRh leading to erratic or unovulatory cycles, with short luteal phase and interference with implantation owing to suckling induced release of oxytocin.

Advantages of Natural Family Planning

- No physical side effect
- No financial cost
- Increases self awareness and knowledge

- It can be provided by trained NFP teacher and not necessarily by highly skilled medical personnel.

Disadvantages

- Do not provide protection against HIV and STDs.
- There may be emotional stress due to abstinence of 10-12 days per cycle.
- Involvement of both partners is essential.
- High failure rate.

Coitus Interruptus (Withdrawal Method)

- It means discharge of semen outside the female genitalia at the end of intercourse.
- This method needs great motivation and self control in male partner and female partner may develop sex neurosis, pelvic congestion syndrome, but there is no definite evidence regarding this.
- Typical average failure rate is 18-20 per 100 women users. The failure is mostly due to lack of male self control, pre-ejaculating discharge and sometimes ascent of sperms from external genitalia.

## B. Barrier Methods

- Barrier contraceptives are family planning methods, which act as barriers and prevent the union of sperms and ovum necessary for pregnancy.
- Recently barrier method of contraception have gained much more importance in view of the facts they prevent precancerous lesions, cancer of cervix and spread of AIDS. Only condoms have been proven to prevent HIV infection. STD protection has a beneficial impact on the risk of tubal infertility and ectopic pregnancy.
- The risk of toxic shock syndrome is increased with female barrier methods but the actual incidence is so rare that this is not a significant clinical consideration.
- Different kinds of Barrier methods are available.

### 1. Condoms

- Male Condoms
- Female Condoms

#### Male Condoms

- It is the only contraceptive proven to prevent HIV infection (Fig. 50.4A)
- Three specific goals
  - correct use
  - consistent use
  - affordable and easy availability
- Various types of condoms are available.

- Most are made of latex. Polyurethane and silicon rubber condoms are also now manufactured.
- Latex condoms are 0.3 to 0.8 mm thick. Sperms that are 0.003 mm in diameter cannot penetrate latex condoms. They are circular, 15-20 cm in length, 3-3.5 cm diameter. (Different sizes are also now available)



Fig. 50.4A: A male condom

- Those individual, who are allergic to latex condoms, can use polyurethane condoms.
- Types — Dry type—Nirodh, Duropac etc.
  - Pre-lubricated—Durax, Kohinoor, Nirodh deluxe, moods etc.
  - Medicated—Coated with nonoxynol-9, Share, Ramses, Dean etc. (These are names of Indian brands of condoms)
- Average life span is 5 years from the date of manufacturing
- Should be kept in cool and dry places.

#### Acceptability and Usage

Condom use is more common in the developed countries where 12 per cent of married women of reproductive age (MWRA) are protected by condoms against 4 per cent in the developing countries. Condom are used worldwide particularly as a preventive measure against HIV and STDs.

#### Effectiveness

Typical average failure rate of condom as commonly used is 12 per cent (WHO 1994).

When used correctly and consistently failure rate is only 3 per cent.

#### Advantages

- Condoms need no prescription and no medical help for use.
- Easily available and harmless method of contraception
- It gives very good protection against STDs, HIV and Hepatitis B virus.
- They are suitable in any age group, during lactation and for those who cannot tolerate oral pills and IUCD's.
- Barrier methods reduce the chance of developing severe cervical dysplasia and cervical cancer.

#### Disadvantages

- Breakage is greater problem for couples at risk of STD.
- Rarely they produce hypersensitisation.
- No major disadvantage.
- Storage and disposal problems.

*How to Use*

A condom must be placed on the penis before it touches a partner. Uncircumscised man should pull the foreskin back. Prior to unrolling the condom to the base of the penis, air should be squeezed out of the reservoir tip with a thumb and forefinger. The tip of condom should extend beyond the end of the penis to provide a reservoir to collect the ejaculate. If lubricants are used, they must be water based. Oil based lubricants will weaken the latex. After intercourse, the condom should be held at the base as the still erect penis is withdrawn. Semen must not be allowed to spill or leak. It should be handled very gently.

If there is evidence of any spillage or leakage or when a condom breaks:

- a. Spermicidal agents should be quickly inserted into the vagina.
- b. Woman should contact a clinician within 72 hours. Emergency contraception should be provided.

*Female Condoms (Fig. 50.4B)*

The female condom is a pouch made of polyurethane, which lines the vagina. An internal ring in the closed end of the pouch covers the cervix and an external ring remains outside the vagina, partially covering the perineum. It is pre-lubricated with silicon, no need to use spermicidal agents. These devices are more cumbersome than male condom and have high rates of problems like slippage.

Efficacy rate similar to diaphragm 5-20/HWY.

2. The Diaphragm (Dutch Cap)



**Fig. 50.4B:** A female condom

The first effective barrier contraceptive method under a woman's control was the vaginal diaphragm. The vaginal diaphragm or Dutch Cap consist of a saucer shaped rubber diaphragm with a metal coil spring in its rim which fits snugly across the upper vagina. There are three types of diaphragms and most manufacturers produce them in sizes ranging from 50 to 105 mm diameter, in increments of 2.5 to 5 mm. Most women use sizes between 65 and 80 mm. Three types of diaphragms (Fig. 50.5) available are as follows:

- Diaphragm with Flat spring
- Diaphragm with Arcing spring
- Diaphragm with Hinged spring

The diaphragm (Fig. 50.5) made with a flat metal spring or a coil spring remains in a straight line when pinched at the edges. This type is suitable for woman with good vaginal muscle tone and an adequate recess behind the pubic arch.



**Fig. 50.5:** Types of diaphragms used



Arcing diaphragms are easier to use for most women. They come in two types. The all flex type bend into an arc no matter where around the rim the edges are pinched together. The Arcing diaphragms allow the posterior edge of the diaphragm to slip more easily past the cervix and into the posterior cul-de-sac. Women with poor vaginal muscle tone, cystocele, rectocele, a long cervix or an anterior cervix of a retroverted uterus use arcing diaphragms more successfully.

The hinged type of diaphragm must be pinched between the hinges in order to form a symmetrical arc. It forms a narrower shape when pinched together and thus may be easier for some women to insert.

### Fitting

Successful use of diaphragm depends on proper fitting. The clinician must have available aseptic fitting rings or diaphragms themselves in all diameters. These devices should be disinfected by soaking in a bleach solution. At the time of pelvic examination, the middle finger is placed against the vaginal wall and posterior cul de sac, while the hand is lifted anteriorly until the pubic symphysis abuts the index finger. This point is marked with the examiner's thumb to approximate the diameter of the diaphragm. The corresponding fitting ring is inserted, the fit to be assessed by both clinician and patient. If the diaphragm is too tightly pressed against

the pubic symphysis, a smaller size is selected. After a good fit is obtained, the diaphragm is removed by hooking the index finger under the rim behind the symphysis and pulling. It is important to instruct the patient in these procedures during and after fitting. The patient should then insert the diaphragm, practice checking for proper placement and attempt removal.

There should be reasonably firm apposition particularly in the posterior fornix and the lower rim should be at least one fingerbreadth above the external urethral meatus.

The diaphragm is compressed with the cavity facing upward and then it is pushed into the vagina as far as it will go. The leading edge is behind the cervix. The front edge is behind the symphysis pubis. Move the finger around the rim, find the bulge of cervix in the middle and it should be snug. For removal, insert the index finger under the front rim and pull downward and outward (Fig. 50.6).

### Timing

The diaphragm should be inserted no longer than 6 hours prior to sexual intercourse. About a tablespoonful of spermicidal cream or jelly should be placed in the dome of diaphragm prior to insertion and source of the spermicide spread around the rim of diaphragm.

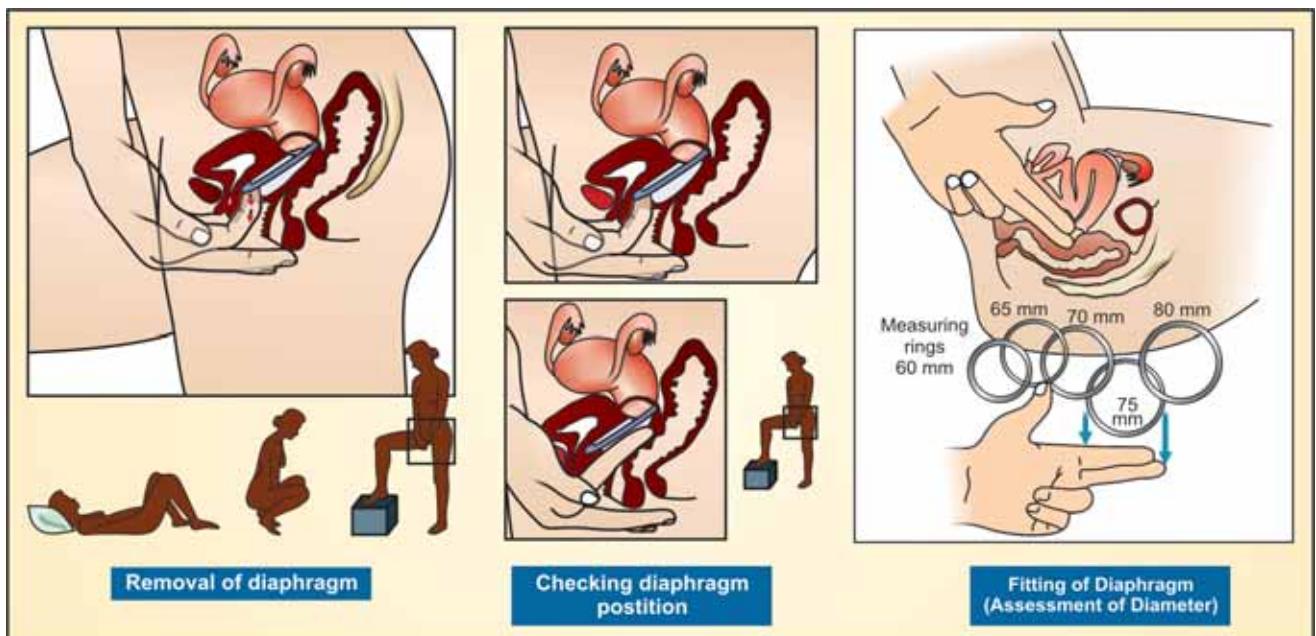


Fig. 50.6: How to use a diaphragm

The diaphragm should be left in place for approximately 6 hours (but not more than 24 hours) after intercourse. Additional spermicide should be placed in the vagina before each episode of sexual intercourse while the diaphragm is in place.

### Reassessment

The fit of a diaphragm should be assessed every year at the time of regular examination. Weight loss, gain, vaginal delivery and even sexual intercourse can change vaginal calibre.

### Care of the Diaphragm

After removal, the diaphragm should be washed with soap and water, rinsed and dried. It should be stored in a cool and dark location. It is wise to use water to periodically check for leaks. The diaphragms need replacement every 6 months to 2 years (depending on its care). The woman should be warned against constipation because a loaded rectum can prevent the diaphragm from fitting accurately.

### Efficacy

Failure rates vary from as low as 2 per cent per year of use to as high as 23 per cent per year. The typical use failure rate after one year of use is 12.1 per cent. Young, literate woman can use diaphragms very successfully if they are properly encouraged and counselled.

### Side Effects

- Less than 1 per cent of women discontinue it because of vaginal irritation caused by latex rubber or spermicidal jelly or cream.
- Urinary tract infections are 2-3 fold more common among diaphragm users than among women using oral pills. Possibly, the rim of diaphragm presses against the urethra and causes irritation which is perceived as infection or true infection sometimes occur from touching the perineal area or incomplete voiding of the bladder. Clinical experience suggest that voiding after sexual intercourse is helpful and if necessary, a single postcoital prophylactic antibiotic can be recommended (cephalexin 250 mg, Nitrofurantoin 100 mg, or trimethoprim-sulfamethoxazole 1 tab postcoitus)

- Improper fitting or prolonged retention can cause vaginal abrasion or mucosal irritation.
- There is no link between the normal use of diaphragms and toxic shock syndrome. It makes sense, however, to minimise the risk of toxic shock syndrome by removing the diaphragm after 24 hours and during menses.

### Advantages

- Diaphragm use reduces the incidence of cervical gonorrhoea, pelvic inflammatory disease and tubal infertility. This protection may be due to the use of spermicide.
- There are no data, as yet, regarding the effect of diaphragm use on the transmission of the AIDS virus.
- Low cost
- Diaphragms are durable and with proper care last for several years.
- It does not interfere with natural coitus.
- It can be used in lactating women and stopped any time.

### Disadvantage

- Difficult to use in women with prolapse or retroversion, in whom a reliable fit is impossible.

### Cervical Cap (Fig. 50.7)

The cervical cap was popular in Europe long before its reintroduction into the United States. The cervical cap is



Fig. 50.7: Cervical Cap

a small, firm cap shaped device which fits over the cervix. It is available in four sizes — 22 mm, 25 mm, 28 mm and 31 mm.

#### *Advantages over the Diaphragm*

- It can be left in place for a longer time (upto 48 hours)
- It need not be used with spermicide. However, a tablespoonful of spermicide placed in the cap before application is reported to increase efficacy.
- Women with pelvic relaxation can use cap.

#### *Disadvantage over the Diaphragm*

- Somewhat harder to fit as it comes in only 4 sizes.
- More difficult to insert as it must be placed precisely over the cervix.
- Efficacy is significantly reduced in parous women.
- Women with a cervix, that is too long or too short or with a cervix that is far forward in the vagina, may not be suited for cap.

#### *Insertion and Removal (Fig. 50.8)*

Those women who can be fitted with one of the 4 sizes must first learn how to identify the cervix and then how to slide the cap into the vagina upto the posterior vaginal wall and onto the cervix. After insertion and after each

act of coitus, the cervix should be checked to make sure, it is covered.

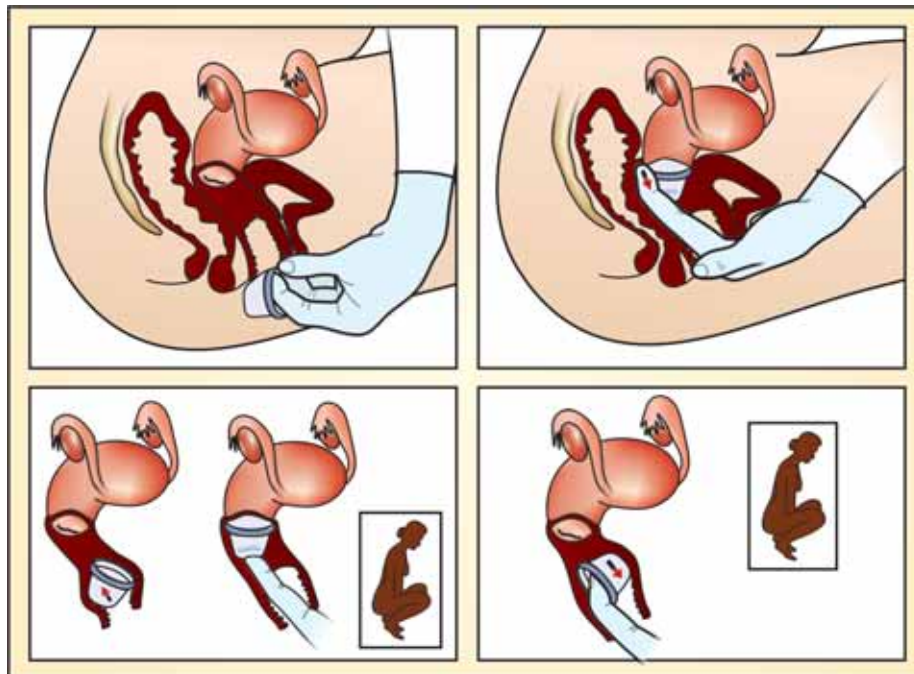
To remove the cap (at least 8 hours after coitus), pressure must be exerted with a finger tip to break the seal. The finger is hooked over the cap rim to pull it out of the vagina.

The most common cause of failure is dislodgement of the cap during coitus. There is no evidence that caps causes toxic shock syndrome or dysplastic changes in the cervical mucosa. They also provide protection from sexually transmitted diseases as diaphragms but not HIV. The cervical caps can be left in place for 2 days but some women develop a fowl smelling discharge by then.

#### *Efficacy*

Failure Rate : 2-20 per HWY of use.

**The fem Cap:** The fem Cap made of nonallergic silicone rubber, is shaped like a sailor's hat, a design that allows a better fit over the cervix and in the vaginal fornices and provides a rim for easier removal. This cap may be easier to fit and use. There are two sizes, one for nulliparous women and a larger size for multiparous women. Because some women experience difficulty in removing fem Cap, a modified fem Cap (with removal strap) is being evaluated.



**Fig. 50.8:** Insertion and removal of cervical cap

*The Contraceptive Sponge or Today Sponge*

- The today sponge is a vaginal contraceptive made of a soft disposable non-abrasive polyurethane foam containing one gram of spermicide, non-oxynol-9.
- It can be easily inserted into the vagina and placed over the cervix and has a ribbon loop attached for easy removal.

*Mechanism of Action*

- a. Blocks entry of sperm into the cervix.
- b. Spermicide kills sperm before they can reach egg.
- c. Sponge itself traps and absorbs sperms into the sponge matrix.

*Advantages*

- Its onset of action is immediate and reversible.
- Provides protection for 24 hours as it contains sufficient spermicide.
- Purchased without prescription.
- It does not disrupt menstrual cycle.
- It is made of soft foam that feels like normal vaginal tissue.

*Disadvantages*

- It does not protect against STD's and HIV.
  - Always wait for at least 6 hours after the last act of intercourse before removing sponge.
  - Allergic reaction in 4 per cent of users can occur.
- Female barrier methods here to be used according to timings. Table 50.1 compares usage timings of various female barrier methods.

*Spermicides*

- Various chemicals and wide variety of vehicles have been used vaginally as contraceptives for centuries.

**Table 50.1: Timings of various methods**

	Diaphragm	Cap	Sponge	Female Condom
Insertion before coitus, no longer than :	6 hrs	6 hrs	24 hrs	8 hrs
After coitus, should be left in place for :	6 hrs	8 hrs	6 hrs	—
Maximal wear time :	24 hrs	48 hrs	30 hrs	8 hrs

- Modern spermicidal agents introduced in 1950s, contain surface active agents that damage the sperm cell membranes, this same action occurs with bacteria and viruses explaining the protection against STDs.
- The agents currently used are :
  - Non-oxynol-9
  - Octoxynol-9
  - Benzalkonium Chloride
  - Menfegol
- Most preparations contain 60-100 mg of these agents in each vaginal application, with concentration ranging from 2-12.5 per cent.
- Available in the form of foam, jellies, creams, vaginal contraceptive film and suppositories.
- "Advantage 24" is a contraceptive gel that adheres to the vaginal mucosa and provide longer availability of non-oxynol-9 effective for 24 hrs.

*Efficacy*

Failure rate of approximately 20-25/HMY during a year of use are most typical.

- The principal minor problem is allergy that occurs in 1-5 per cent of users.
- Spermicide users who have an altered vaginal flora, providing the colonisation of *E. Coli.*, leads to greater susceptibility of urinary tract infections.
- Spermicides should not be used without condoms if a primary objective is to prevent infection with HIV, gonorrhoea and chlamydia.

**C. Intrauterine Contraceptive Device (IUCD)**

- Intrauterine contraceptive devices are made of plastic or metal or combination of these materials, meant for insertion into the uterine cavity for contraception.
- The IUCD is the second most commonly used family planning method, after voluntary female sterilisation (WHO 1997).
- IUCDs are an effective, safe and convenient contraceptive method. They are particularly suitable for woman who
  1. Want to delay pregnancy for some years
  2. Are breast feeding
  3. Prefer method that does not require supervision or action before sexual intercourse.

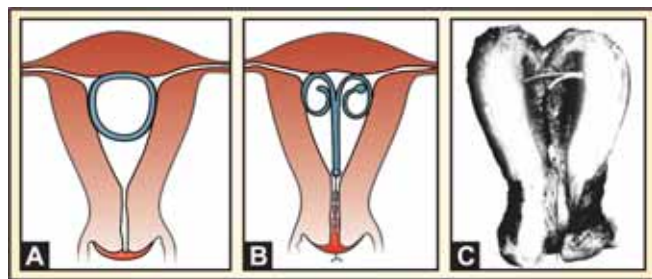
*History*

First widely used IUCD was introduced in Germany by Grafenberg in late 1920s known as Grafenberg ring. OTA

rings developed in Japan. These are composed of relatively non-irritant metal such as silver, gold and alloy of copper. The addition of copper was suggested by Zipper. The progesterone was developed by Alza Corporation. The progesterone diminishes the account of cramping and the amount of blood loss. The short life span has been solved by using a more potent progesterone such as levonorgestrel. The IUCDs of the future will possibly be medicated and frameless.

**Types of IUCDs (Figs 59.9A to C and 50.10)**

- a. Unmedicated or Inert IUCDs  
e.g. lippies loop, saft coil, OTA ring, Mahua ring
- b. Medicated IUCDs  
Cu releasing IUCDs—Cu 7, CuT200, Multiload Cu 250, Multiload Cu375, Novat, Cu T380 Ag, CuT 380A  
Hormone releasing IUCDs—Progesterone, Levonorgestrel IUCD.



Figs 50.9A to C: IUCD's in uterus

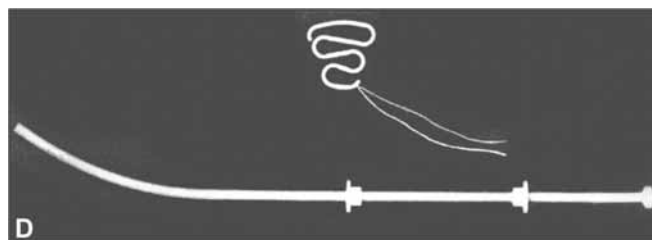


Fig. 50.9D: D lippies loop

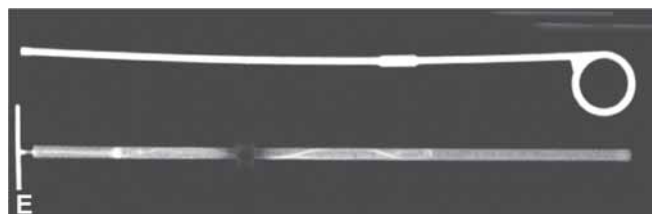


Fig. 50.9E: Cu-T

**a. Lippies Loop (Fig. 50.9D)**

Unmedicated IUCD, made of plastic (polyethylene) impregnated with barium sulfate. It is still used throughout the world except in the U.S. Flexible stainless steel rings are widely used in China. The inserter is of push out type.

**b. Copper Releasing IUCDs**

The 1st Copper IUCDs were having 200 to 250 mm<sup>2</sup> of wire e.g. CuT200 (Fig. 50.9E) and multiload 250. The more modern copper IUCDs contain more copper and part of copper is in the form of solid tubular sleeves rather than wire, increasing efficacy and extending life span e.g. CuT 380A (Paragard) NovaT, multiload 375.

**CuT 200**—The device is made of polypropylene impregnated with barium sulfate and carries 120 mg of 0.25 mm diameters Cu wire wound round the vertical limb. The copper portion has an exposed surface area of 200 sq. mm. The inserter is of withdrawal type.

**CuT 380A** is a T shaped device with a polyethylene frame holding 380 mm<sup>2</sup> of exposed surface area of

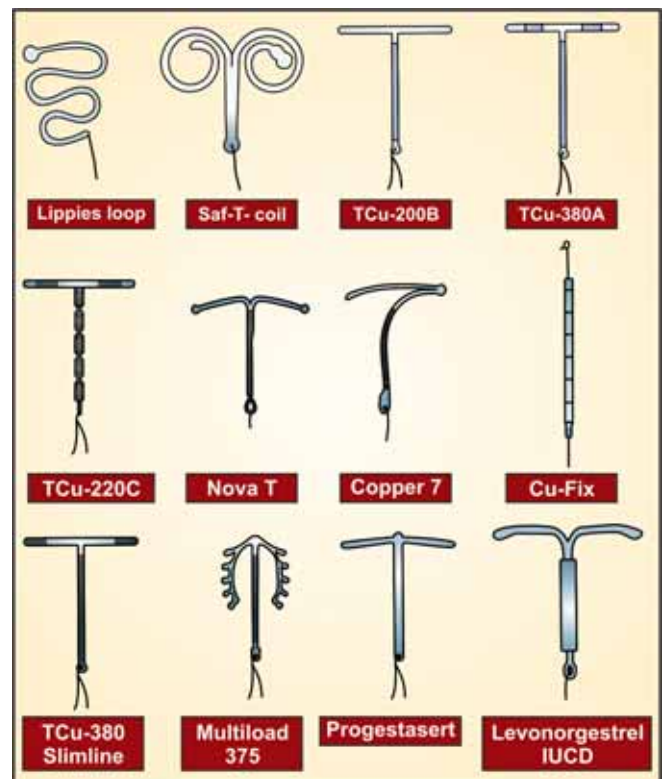


Fig. 50.10: Types of IUCD's

copper. The pure electrolytic Cu wire wound around the 36 mm stem weigh 176 mg and copper sleeves on horizontal areas weigh 66.5 mg. A polyethylene monofilament is tied through the 3 mm ball on the stem, providing two white threads for detection and removal. The ball at the bottom of the stem helps to reduce the cervical perforation. The IUCD frame contains barium sulfate, making it radio-opaque. The Cu T 380Ag is identical to Cu T 380A, but the copper wire on the stem has a silver core to prevent fragmentation and extend the lifespan of the copper. The Cu T 380 slimline has the sleeves flush at the ends of the horizontal arms to facilitate easier loading and insertion. The lifespan of the Cu T 380A is 10 years, Cu T 380Ag is 4 years and Cu T 380S is 2½ years.

**The Multiload-375** has 375 mm<sup>2</sup> of copper wire wound around its vertical stem. The flexible arms were designed to minimise expulsion. This is a popular device in many parts of world. The multiload Cu 250 has a recommended lifespan of 3 years and multiload Cu 375 has a lifespan of 5 years.

**The Nova T** is similar to the Cu T 200, containing 200 mm<sup>2</sup> of copper, however, the Nova T has a silver core to the copper wire, flexible wire and a large flexible loop at the bottom to avoid injury to cervical tissue. There was some concern that the efficacy of the Nova T decreased after 3 years in WHO data, however results from some other countries indicate low pregnancy rates even after 5 years of use.

### Hormone Releasing IUCDs

1. **Progestasert:** This device is T shaped IUCD made of ethylene vinyl acetate copolymer containing titanium oxide. The vertical stem contains a reservoir of 38 mg progesterone together with barium sulfate dispersed in silicone fluid. The horizontal arms are solid and made of the same copolymer. Two blue-black monofilament strings are attached at a hole in the base of the stem. The progesterone is released at a rate of 65 µg/day. Its effective life span is only one year.
2. **Levonorgestrel IUCD LNG 20, Levonova or Mirena):** This device is manufactured by Leiras in Finland releasing 20 mg of LNG per day. This T shaped device has a collar attached to the vertical stem, which contains 52 mg LNG dispersed in polydimethylsiloxone and released at a rate of 15-20 µg/day. The LNG IUCD

has a life span of 10 years and reduces menstrual blood loss and pelvic infection rates.

### Future IUCDs

The Ombrelle 250 and Ombrelle 380 are designed to be more flexible in order to reduce expulsion and side effects, have been marketed in France.

**A Frameless IUCD**, the flexigard also known as Cu fix IUCD or Gynefix consists of 6 copper sleeves (330 mm<sup>2</sup> of Cu) strung on a surgical nylon or polypropylene thread that is knotted at one end. The knot is pushed into the myometrium during insertion with a notched needle that works like a miniature harpoon. Because it is frameless it has a low rate of removal for bleeding or pain, but a more difficult insertion may yield a higher expulsion rate. However in expert hands, expulsion rate is low. This device is especially suitable for nulligravid and nulliparous women.

### Mechanism of Action

- The contraceptive action of all IUCDs is mainly in the uterine cavity.
- **Nonmedicated IUCDs:** It depends for contraception on the general reaction of the uterus to a foreign body, a sterile inflammatory response sufficient enough to be spermicidal. So very few, if any, sperm reach to the ovum in the fallopian tube. Inflammatory response would also prevent implantation.
- **Cu IUCDs:** The Cu IUCDs release free copper and copper salts that have both a biochemical and morphological impact on the endometrium and also produce alteration in cervical mucus and endometrial secretions. The Cu IUCD is associated with an enhanced inflammatory response, marked by production in the endometrium of cytokine peptides breakdown and enhanced prostaglandin production.
- **The Progestrone Releasing IUCDs:** It adds the endometrial action of progesterone to the foreign body reaction. The endometrium becomes decidua-lised with atrophy of glands. It causes inhibition of implantation and inhibition of sperm capacitation and survival. Progesterone IUCD thicken the cervical mucus, creating a barrier to sperm penetration. They decrease menstrual blood loss (by about 40-50%) and dysmenorrhoea.
- **LNG IUCD:** Produces serum concentration of the progestin about half that of Norplant so that ovarian

follicular development and ovulation are also partially inhibited. Bleeding can be reduced by 90 per cent, one year after insertion.

### Time of Insertion

- During menstruation or on the last day of menstruation. Advantages of insertion during menses or shortly after are (a) cervical canal more open so insertion is easier, (b) masking insertion related bleeding, (c) knowledge that the patient is not pregnant.
- After childbirth can be inserted anytime within 48 hours or as early as within 4-6 weeks of delivery. The disadvantages of immediate postpartum insertion is higher expulsion rate and uterine perforation.
- Postcoital insertion should be done within 5 days of an unprotected intercourse.
- Postabortal insertion of IUCD can be done safely immediately after evacuation of uterus. Postabortion insertion has a high acceptance rate.
- Insertion in lactating woman is safe, as it does not affect the quantity and quality of breast milk.

### Insertion Technique (Fig. 50.11)

- Before any IUCD is inserted the patient should be informed, preferably in writing, of the principles involved in the method, its possible side effects, management and failure rate. She should give written consent for the insertion.
- Prior to the operation, complete history and a complete pelvic examination should be carried out to exclude any abnormality and cervical smear taken for cytology.
- All the plastic IUCDs have their own introducer as well as attached nylon tails, which hang through the cervix into the vagina. These permit the woman and her medical attendant a means of confirming that the device is in place and also of removing it by simple traction.
- The plastic material is impregnated with barium sulfate so the presence and position of device can be confirmed radiologically.
- After the application of an antiseptic the length of the uterine cavity is measured by a uterine sound and its direction confirmed.
- An appropriate device is then chosen and loaded into its introducer, which is passed into the uterus upto

its flange or another marker. The method of insertion now depends on the device used. When the lippies loop plunger is pressed to release the device, resumes its inherent shape to lie in the uterus. With Cu T, the loaded applicator is passed upto the fundus and the sheath is withdrawn to release the device.

- The plunger is then withdrawn together with the introducer, leaving the nylon threads in the vagina, these are shortened to a reasonable length.
- After the insertion the patient should rest for 10-15 minutes and remain under observation as she may feel faint.
- The woman should be taught to feel for and recognise the threads. She should also be fully aware of the shape of the IUCD inserted.
- If at any time during the procedure, the woman experiences significant pain or she collapses, the procedure should be abandoned. Difficulty in inserting the sound or introducer through the cervix calls for greatest caution because it is easy to make a false track and perforate the tissues (Figs 50.12 and 50.14).

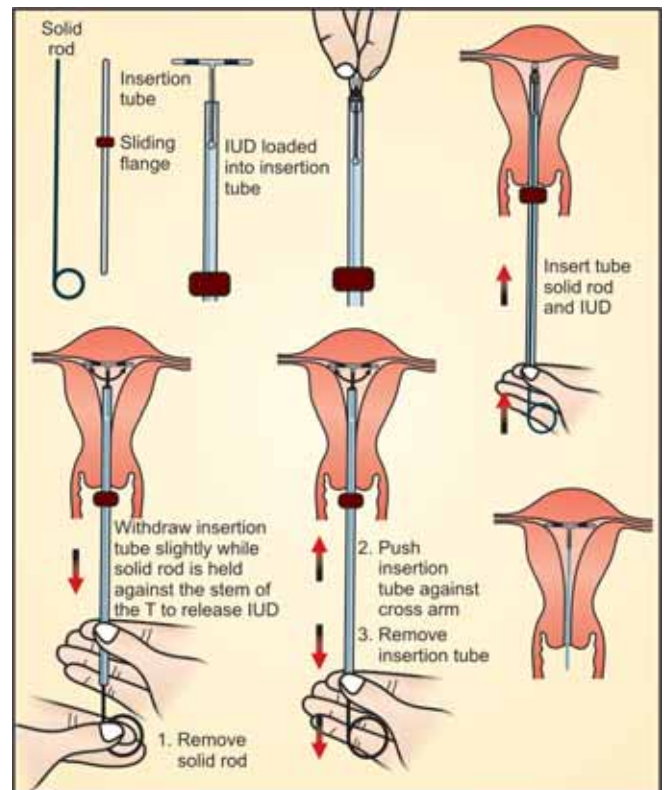
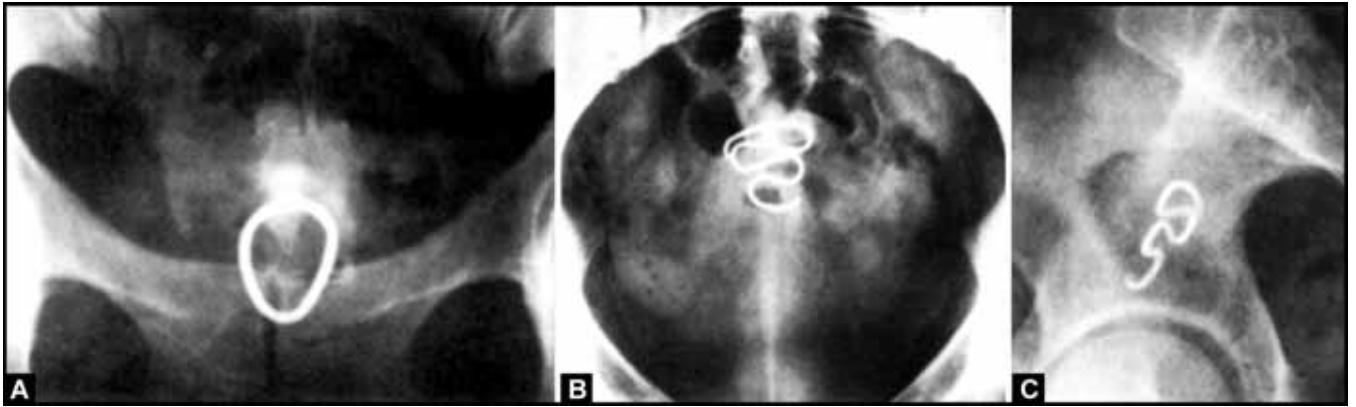


Fig. 50.11: Technique of insertion



**Figs 50.12A to C:** Devices in proper position in the uterus as shown by radiography: (A) Grafenberg ring (B) Lippies loop; anteroposterior and (C) Lateral views

### Further Supervision and Management

- Before or at the time the IUCD is introduced, the patient should be warned of possible initial reactions such as uterine bleeding and colic, and be told to report any significant reactions immediately.
- In any case, she should have routine follow-up visit immediately after her next menstrual period so that the retention of the device can be checked and any adverse side effects discussed.
- Next follow up after 3-6 months is desirable; thereafter the woman is seen at yearly intervals, when if necessary, the device can be removed and a new one inserted.
- There is no time limit for leaving inert devices in place and one can remain for several years without any harmful result. Sometimes after a year or two, they do get embedded in the endometrium and cause bleeding and discharge. This is an indication for taking out device and inserting a new one after next menses.
- Copper devices need to be replaced at intervals specified by the manufacturers. CuT 200 is recommended for 3 years, multiload 250 for 3 years multiload 375 for 5 years and CuT 380 last for 10 years.
- IUCD is removed permanently once the menopause is established or if, at any time it causes unacceptable symptoms. If the device originally chosen is extruded, it is necessary to replace it with one of a different size or shape.
- Prospective IUCD users should be aware of the following important possibilities:

- a. Protection against unwanted pregnancy begins immediately after insertion.
- b. Menses can be longer and heavier except hormonal IUCD.
- c. Slightly increased risk of pelvic infection in the first few months after insertion.
- d. Protection against STDs requires the use of condoms.
- e. Ectopic pregnancies can still occur.
- f. The IUCD can be spontaneously expelled, monthly palpation of the IUCD strings is important to avoid unwanted pregnancies. If the strings are not felt, a clinician should be notified immediately.

### Indications

- Those who want that one time insertion lasts for many years.
- The method required is the one which is independent of the act of coitus.
- IUCD are especially valuable in irresponsible woman or for the mentally challenged.
- In whom oral contraceptive pills are contraindicated and do not want to use other methods.
- As an emergency contraception.

### Contraindications

1. Woman with irregular and heavy periods, uterine leiomyoma or other pelvic disease.
2. When there is evidence of present or past pelvic infection of any kind.



3. If the uterus is bicornuate. In this, pregnancy in one horn may be protected and a conceptus can implant in the other.
4. Nulliparous woman
5. Diabetes and heart disease
6. A history of previous ectopic pregnancy (doubtful).

### Efficacy of IUCDs

1st year clinical trial results in parous women

Device	Pregnancy Rate	Expulsion Rate	Removal Rate
Lippies Loop	3%	12-20%	12-15%
CuT 200	3%	8%	11%
CuT 380A	0.5-0.8%	5%	14%
Progestasert	1.3-1.6%	2.7%	9.3%
Mirena	0.2%	6%	17%

Considering all IUCDs together, the actual failure rate in the 1st year of use is approximately 3 per cent, with a 10 per cent expulsion rate and 15 per cent rate of removal mainly for bleeding and pain. With increasing duration of use, failure rate decreases. The performance of CuT 380A in recent years has proved to be superior.

Failure rates with CuT 380A and other new Cu IUCDs is less than one per 100 women/year.

### Expulsion

Approximately 5 per cent of patients spontaneously expel the CuT 380A within first year. This event can be associated with cramping, vaginal discharge or uterine bleeding or sometimes lengthening or absence of IUCD string. Patient should be cautioned to request immediate attention if expulsion is suspected.

### Ectopic Pregnancy

The previous use of an IUCD does not increase the risk of subsequent ectopic pregnancy. The current use of IUCD, other than the progestasert, offer some protection against ectopic pregnancy. Therefore when an IUCD user becomes pregnant, the pregnancy is more likely to be ectopic. However, the actual occurrence of an ectopic pregnancy in an IUCD user is a rare event. The lowest ectopic pregnancy rates are seen with the most effective IUCD like CuT 380A = 0.20 per cent, LNG IUCD 0.20 per 1000 women year (90% less likely compared with noncontraceptors).

Progestasert has a higher rate 6.8 per 1000 women year because its action is limited to a local effect on the endometrium.

So the protection against ectopic pregnancies provided by CuT 380A and LNG IUCD makes these IUCDs acceptable choices for contraception in women with previous ectopic pregnancies.

### Adverse Effects and Complications of IUCDs

1. Fainting or collapse of the patient at the time of insertion of the IUCD.
2. Intermenstrual spotting or menorrhagia occurs in about 55 per cent of women. They are mostly seen during the first few days and months and tend to disappear later. Nevertheless, a tendency of anaemia can result.
3. Dysmenorrhoea or intermenstrual pain due to uterine colic, these subsides as the patient becomes tolerant or patient can be treated with nonsteroidal anti-inflammatory agents during the first few cycles for 3-5 days.
4. Amenorrhoea can develop sometimes with progestasert and LNG IUCDs due to decidualising atrophic impact on the endometrium with LNG IUCD; 70 per cent of patients are oligomenorrhoeic and 30 per cent amenorrhoeic within 2 years.
5. **Endometritis:** IUCD always cause local foreign body reactions in the endometrium; aseptic endometritis, pressure atrophy, glandular hyperplasia, oedema, leucocytic infiltration are all reported. Such reactions disappear quickly, once the device is removed, probably because of the natural monthly shedding of the endometrium.
6. **Cervical Injury:** Sometimes devices can cause ulceration of the cervical tissues. Abnormal cervical smears are found but it is very rare.
7. Acute and chronic salpingo-oophoritis occur in 1 per cent of women per year. This happen mostly when infection has been present already and has passed unrecognised or when it is inserted too soon after delivery or abortion. The presence of the IUCD may also encourage exposure to a new STD and if the infection is contracted, it is more likely to spread to the tubes if an IUCD is in place. If infection does occur, antibiotic therapy should be given and the device removed. The previous presence of infection

with IUCD does not alter the treatment of PID. IUCD associated pelvic infection is more likely to be caused by non STD organisms. HIV infected women who utilise IUCDs for contraception do not have a greater incidence of complication including PID.

8. **Actinomyces:** The significance of actinomycosis infection in IUCD users is unclear. There has been some evidence of actinomycosis in cervical smears from IUCD users (around 30%). The rate is much lower (less than 1%) with copper devices and varies with duration of use. The clinician must decide whether to remove the IUCD and treat the patient or treat with IUCD in place or simply remove the IUCD. If uterine tenderness or pelvic mass is present, then IUCD should always be removed after the initiation with oral penicillin G 500 mg QID that should continue for a month. Timely detection and treatment prevents the development of pelvic actinomycotic masses.

9. **Perforation of Uterus:**

Sometimes the IUCD penetrates the uterine wall and escapes into the peritoneal cavity and causes adhesions and intestinal obstruction. It is nearly always the result of the uterine wall being perforated or deeply injured at the time of the insertion. Once in the peritoneal cavity IUCD travels to any site. Without X-ray screening it can sometimes be very difficult to find the device at laparoscopy or laparotomy. If it is an inert device, there is often no need to remove it.

In case of copper IUCD, removal is always indicated as there is risk of pelvic adhesions due to continuous release of copper. Removal is often possible by laparoscopy rather than by laparotomy.

10. **Embedded IUCDs:** If removal of IUCD is not easily accomplished, direct visualisation of the IUCD with sonography or hysteroscopy can be helpful. Sonography is safer and less expensive. Under abdominal ultrasound guidance, we can remove it by forceps. If this method fails then hysteroscopy is indicated.

11. **Displaced IUCD:** When an IUCD cannot be found on expulsion, one has to consider perforation in abdominal cavity or embedment into the myometrium. A quick, real time sonography is the best method to locate a lost IUCD whether or not removal is desired. If the IUCD cannot be visualised by ultrasound, abdominal X-rays are necessary because the IUCDs are radio-opaque and can be high and hidden. If the IUCD is identified perforating the myometrium or in abdominal cavity, it should be removed using operative laparoscopy under general anaesthesia. If it is located in the uterine cavity, first try to remove it under ultrasound guidance otherwise hysteroscopy is the best approach (Fig. 50.13).

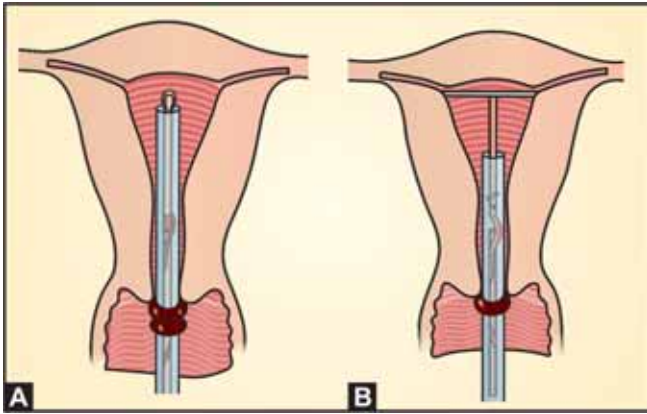
12. Spontaneous expulsion occurs during the first year in 2-10 per cent of cases, particularly common if it is introduced in the early puerperium while the cervix is still atonic and sometimes the IUCD tail gets entangled with a vaginal tampon and pulled out inadvertently.

13. **Pregnancy with an IUCD in Situ:** The incidence of pregnancy with IUCD in place is 2 per cent during the first year after insertion, thereafter the rate increases to 3 per cent. Complications associated with it are :

i. **Spontaneous Miscarriage:** Spontaneous miscarriage occurs in approximately 40-50 per cent



**Figs 50.13A to C:** Intra-peritoneal translocation of IUCD (A) Radiograph taken after 2 months of insertion because nylon tail was no longer projecting through cervix (B) Radiograph 18 months later showing loop in peritoneal cavity (C) Extra-uterine site of IUCD



**Figs 50.14A and B:** The principles governing the insertion of a Copper T: (A) The loaded introducer is inserted up to the fundus of the uterus. (B) Insertion is by withdrawal of the introducer over the plunger. The device is removed by pulling out the 'tail'

of cases. After removal of IUCD with visible strings, spontaneous miscarriage rate is approximately 30 per cent. So if the IUCD is easily removed without trauma or expelled during the first trimester, risk of spontaneous miscarriage is not increased.

- ii. **Septic Abortion:** There is no evidence that there is an increased risk of septic abortion if pregnancy occurs with IUCD *in situ* except the Dalkon shield. If a patient plans to terminate a pregnancy, IUCD should be removed in a clinic if there is no evidence of infection. If an IUCD is in infected pregnant uterus, removal of the device should be undertaken only after antibiotic therapy has been initiated and equipment for cardiovascular support and resuscitation is immediately available as removal in infected uterus can lead to a septic shock.
- iii. **Preterm Labour and Births:** The incidence is increased approximately 4 fold when IUCD is left in place during pregnancy.
- iv. **Congenital Anomalies:** There is no evidence that exposure of the foetus to medicated IUCD is harmful. The risk of congenital malformation is increased among infants born to woman with IUCD in place during pregnancy.
- v. **Other Complication:** Obstetrical complication at delivery (e.g. haemorrhage, stillbirth and difficulties with place of removal) have been reported only with the Dalkon shield *in situ*.

### Advantages

- They offer a cheap and practical means of considerably lowering fertility for a reasonably long period without the woman needing to pay any heed.
- No serious side effects if occur, they disappear immediately after the device is removed.
- This method does not require privacy or toilet facilities, as does the use of diaphragm.
- It does not lower fertility.
- It can be used as emergency contraception within 5 days of unprotected intercourse.
- No interaction with any medicine.
- No hormonal side effects
- No effect on amount or quality of breast milk.

### D. Combined Hormonal Contraception

The combined oral contraceptive pill (COC) was introduced in the early 1960s and is currently used by more than 60 million women worldwide. The combined pill is popular because of its efficacy, ease to use and additional health benefits beyond those of contraception. In recent years, new delivery systems for combined hormonal contraception have become available. The contraceptive patch 'EVRA' was marketed in the UK in 2004. The combined contraceptive vaginal ring, 'Nuvaring' is available in Europe and in the USA combined injection 'Lunelle'. It is also available in some parts of Europe. The mechanism of action and efficacy of these new delivery systems are the same as for combined oral contraception.

#### Combined Oral Contraceptive Pills

Combined hormonal oral contraceptive pills contain both oestrogen (usually ethinyl oestradiol) and a progestogen.

**Oestrogen:** Ethinyl oestradiol is a very potent oral oestrogen used in oral contraceptives. The dose of oestrogen used in the combined pill ranges from 15 µg to 50 µg. Low dose oral pills containing 20-35 µg of oestrogen are also available. Low dose pills are safer because cardiovascular risk and risk of thrombosis are mainly from oestrogen content of pill and are dose related. Therefore, the dose of oestrogen is a critical issue in selecting an oral contraceptive.

**Progesterone:** The progestational derivatives of testosterone were designated as 19-nortestosterones (denoting the missing 19-carbon). The androgenic properties of these compounds were not totally

eliminated and minimal anabolic and androgenic potential remains within the structure.

Progestogens used in currently available pills are divided into four groups:

- First generation progestogens = Norethindrone group.
- Second generation progestogens = Norgestrel group. 0.05 – 0.25 µg of levonorgestrel which is an active isomer of norgestrel
- Third generation progestogens = gestodene 0.075 µg, desogestrel 0.15 µg, norgestimate 0.25 µg
- Newest progestogens — drospirenone has antiandrogenic and antimineralocorticoid activity.

Different progestogens have different potencies and so contraceptive effectiveness is achieved at different doses. The main function of progestogens is to counteract undesirable side effects of oestrogen such as endometrial hyperplasia and heavy withdrawal bleeding. The third generation progestogens have a higher affinity for the progesterone receptor and therefore have a role in inhibiting ovulation. For this reason, comparable contraceptive efficacy is obtained even when low dose formulations with 20 µg of ethinyl oestradiol are used, although these may be associated with poorer cycle control.

New progestins, because of their reduced androgenicity, predictably do not adversely affect the cholesterol-lipoprotein profile and may be of greater clinical value in the treatment of acne and hirsutism.

Definitions used in epidemiologic studies:

- **Low dose oral contraceptives**—products containing less than 50 µg ethinyl oestradiol.
- **First generation oral contraceptives**—products containing 50 µg or more of the ethinyl oestradiol.
- **Second generation oral contraceptives**—products containing levonorgestrel, norgestimate and the other members of the norethindrone family and 30 or 35 µg ethinyl oestradiol.
- **Third generation oral contraceptives**—products containing desogestrel or gestodene with 20 or 30 µg ethinyl oestradiol.

**Formulations:** Combined OC pills are available in monophasic preparation (in which every pill in the packet contains the same dose of steroids) and biphasic and triphasic preparations (in which the dose of both oestrogen and progestogen changes once or twice over the 21-day period). Biphasic and triphasic pills were introduced to reduce the total dose of progestogens and

in the belief that a regimen that mimicked the hormonal cycle would produce better cycle control. However, there is no evidence for better cycle control and some women find such preparations confusing particularly when they want to take two packets of pills consecutively to postpone menstruation.

In an attempt to improve the compliance, everyday preparation are used widely. These regimens involve the taking of inactive tablets rather than 7 days without pills.

#### Mode of Action

- Inhibition of ovulation
- Changes in cervical mucus that interfere with sperms transport
- Tubal motility may be altered
- Atrophy of endometrium
- Uterine receptivity essential for successful implantation may be impaired (Fig. 50.15).

#### Action of Oestrogen

- ↓ FSH release
- Prevent emergence and selection of dominant follicle
- Provide stability to endometrium
- Prevent irregular shedding and unwanted breakthrough bleeding
- Potentiates the action of progestational agents.

#### Action of Progestogens

- Prevent LH surge necessary for ovulation
- Cervical mucus becomes thick and impervious to sperm transport

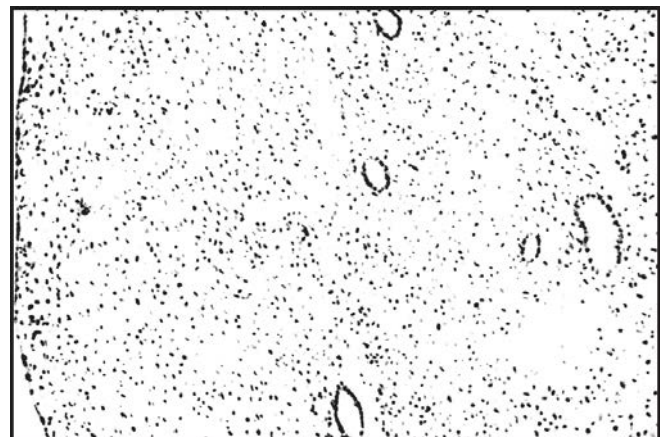


Fig. 50.15: Histology of endometrium

- Produces an endometrium not receptive for implantation (decidualised bed with exhausted and atrophic glands)
- Influences secretion and peristalsis of fallopian tube
- Counteracts undesirable side effects of oestrogen like endometrial hyperplasia and heavy withdrawal bleeding.

### Technique

- The prescription of these oral contraceptives is preceded by a full clinical assessment of the woman to exclude contraindications and pelvic disease and for cervical cytology.
- If all is well and possible initial side effects have been explained, the woman is instructed to take one pill at the same time each day, preferably at night.
- Treatment is commenced on the first or fifth day of the cycle and continued for 21 days.
- Withdrawal bleeding which simulates a normal period commences 2 or 3 days later when administration is discontinued, the course is then repeated, starting again after 7 tablet free days. For simplicity some pills are supplied in a pack of 28 pills those covering the last 7 days are inert pill containing iron.
- If treatment is started on the first day, contraceptive efficacy is obtained from the first cycle. However, to be sure that the period was normal one and that the patient does not, for example, have an ectopic pregnancy, it is safer to start the OCs on the fifth 5th day, using additional barrier contraception in the first cycle.
- An illness causing vomiting or diarrhoea interferes with the absorption of the hormones and the woman should be warned that, in such circumstances, she is unprotected.
- For patients who are lactating, the course of treatment should be commenced 6 months after delivery because combined pills affect the quality and quantity of breast milk. Such woman can be offered the progesterone only pill or depot preparation safely.
- It is recommended that all women should be monitored by regular medical supervision and examination including measurement of blood pressure, blood sugar, liver function tests and tests for blood lipids preferably at interval of 6-12 months as well as regular cervical cytology.

Advice for women missing combined oral contraceptive (COC) (30-35 µg and 20 µg ethinyl oestradiol formulations).

1. If one or two 30-35 µg ethinyl oestradiol pills have been missed at any time or if one 20 µg ethinyl oestradiol pill is missed:
  - She should take the most recent missed pill as soon as she remembers
  - She should continue taking the remaining pills daily at her usual time
  - She does not require additional contraceptive protection
  - She does not require emergency contraception
2. If three or more 30-35 µg EE pills have been missed at any time or two or more 20 µg EE pills have been missed:
  - She should take the most recent missed pills as soon as she remembers.
  - She should continue taking the remaining pills daily at usual time.
  - She should be advised to use condoms or abstain from sex until she has taken pills for 7 days in a row (because extending the pill free interval is risky).
  - In addition
    - a. If pills are missed in week 1 (day 1-7):  
(Since the pill free interval has been extended) emergency contraception should be considered if she had unprotected sex in the pill free interval or in week 1.
    - b. If pills are missed in week 3 (day 15-21):  
In order to avoid extending the pill free interval, she should finish her current pack and start a new pack the next day, thus omitting the pill free interval.
    - c. If pills are missed in week 3 (day 15-21):  
In order to avoid extending the pill free interval, she should finish her current pack and start a new pack the next day, thus omitting the pill free interval.

### Efficacy

When used correctly, combined hormonal contraceptive are almost 100 per cent effective. The failure rate during perfect use is 0.1 per cent. Because of errors in pill taking, failure rate associated with typical use of pills is about 8 per cent.

*Advantages*

- If instructions are followed and the pill is taken regularly, the pregnancy rate is as low as 0.1 per HWY, though in actual use it may be 6-8 per HWY.
- Once the pill habit is acquired the method is simple, divorced from single act of intercourse and aesthetically attractive.
- The woman enjoys a self-controlled regular 'menstrual' cycle, which is usually lighter and without dysmenorrhoea.
- The incidence of anaemia is decreased.
- If the woman decides to have more children, discontinuation of the medication is usually quickly followed by conception. Regular ovulation returns within 3 months in 98 per cent of cases.
- It protects against ectopic pregnancy, benign breast disease, pelvic inflammatory disease, ovarian cysts, ovarian and endometrial cancer.
- This is one of the best methods of contraception especially true for women less than 35 years of age and even after, if they do not smoke.

*Contraindications*

Absolute contraindications (WHO medical eligibility criteria category 4 conditions) to the combined pill are listed in Table 50.2. Relative contraindications (WHOMEC category 3 or 3/4 conditions) include the presence of serious or multiple risks for arterial disease including hypertension, diabetes, smoking, age >35 years, obesity and migraine (Table 50.3).

Women with hyperprolactinaemia should be advised to use progestogen only contraception because oestrogen

stimulates lactotrophes, thus increasing the prolactin concentration.

*Side Effects*

Combined hormonal contraception has an effect on almost every system in the body. Most side effects like nausea, vomiting, mood change, weight gain or fluid retention, headache, loss of libido, mastalgia, breast enlargement and greasy skin are minor common complaints which also occur in the absence of contraceptive use. Many improve or disappear within 3-6 months of starting the method but side effects often lead to discontinuation. Some side effects may be alleviated by changing to different delivery system. For example, the patch associated with less nausea. Among pill users the dose of oestrogen or type of progestogen can be altered by changing to a different brand of pill and it is worth trying this if time alone does not solve the problem. Chloasma is much less common and is definitely related to steroid hormones. It can also occur with progestogen only methods.

Serious side effects involve mainly the cardiovascular system. COC affects both the venous (venous thromboembolism VTE) and arterial (myocardial infarction, cerebrovascular accidents) circulations. In both cases the increased risk appears to be related to an increased thrombotic tendency.

Side effects are :

- **Nausea and vomiting:** These subside within a few months and less troublesome if the pill is taken with milk.

**Table 50.2: Category 4 Condition (Absolute Contraindications)**

- Breastfeeding >6 weeks postpartum
- Smoking >15 cigarettes/day and aged >35 year
- Blood pressure >160/100
- Hypertension with vascular disease
- History of or current deep venous thrombosis
- Major surgery with prolonged immobilisation
- Focal migraine
- Severe cirrhosis
- Liver tumour
- Current breast cancer
- Complicated valvular heart disease
- History of stroke
- History of or current myocardial infarction

**Table 50.3: Category 3 and 3/4 Conditions (Relative Contraindication)**

- Breastfeeding 6 weeks to 6 months postpartum
- Before 3 weeks after childbirth
- Smoking <15 cigarettes/day and aged >35
- Adequate controlled hypertension
- Blood pressure >140/90
- Severe hyperlipidaemia
- Non focal migraine and age >35
- Past breast cancer — 5 years without recurrence
- Past CoC related cholestatic
- Mild cirrhosis
- Current or medically treated gall bladder disease

*Category 3/4 Conditions*

- Multiple risk factors for cardiovascular disease
- Diabetes with retinopathy, nephropathy, neuropathy other vascular disease or of >20 years duration

- **Headache and dizziness:** Except for the rare development of migraine, such symptoms are not significantly associated with treatment.
- **Mastalgia:** This is temporary and can be disregarded
- Chloasma is rarely a nuisance
- Depression and lassitude are often present before treatment is commenced. If they are a result of the pill they may be prevented by giving pyridoxine 50 mg daily.
- Acne and greasy scalp low dose pills improves
- **Loss of libido:** This may be caused by dryness of the vagina and emotional changes but is rarely experienced by women.
- Muscle cramps in the legs
- Breakthrough uterine spotting is common in the early months and rarely needs treatment. If it does, a more oestrogenic preparation is indicated.
- **Menstrual Upsets:** Scanty menstruation is of no importance. Menorrhagia calls for a preparation, which is more progestogenic. Amenorrhoea, with or without galactorrhoea is an indication for stopping treatment. When this is done, menstruation usually returns but amenorrhoea can be persistent. This is more likely in women whose original menstrual cycle is irregular and infrequent and is a sequel to oral contraceptive in less than 1 per cent of case.
- Candida vulvitis and vaginitis is encouraged by the environment, which mimics that of pregnancy.
- **Increase in weight:** This occurs temporarily as a result of fluid retention. A persistent increase in weight is caused by deposition of fat as in pregnancy and is related to a change in appetite.
- The absolute risk of VTE in COC users is very low (15/10,000 women years). The risk returns to normal within 3 months of stopping the pill. The committee on safety of medicines warns that women should be informed of the increased risk of VTE if third generation pills are prescribed. Risk of VTE is same with other routes of administration of combined hormonal contraception (patch, ring or injectable)
- Women with inherited thrombophilias (e.g. factor V leiden) are at increased risk of VTE, and a family history of VTE is an indication for testing for various thrombophilias.
- Smoking has no effect on the risk of venous thrombosis

### Arterial Thrombosis

Arterial disease in pill users is much more serious than venous disease; however the absolute risk of myocardial infarction and stroke in young women is less. Stroke is the most important possible side effect.

### Myocardial Infarction

While there is widespread agreement that there is an increased risk of myocardial infarction among woman who take the pill and smoke or have hypertension, the relationship between myocardial infarction and COC use is controversial among women with no other risk factors.

- A recent meta-analysis of 23 studies concluded that the risk of myocardial infarction was increased among current COC users compared with newer users.
- The risk among past users was not increased nor was the risk for women using third generation pills or pills containing 20 µg EE. The risk for myocardial infarction was increased for women using second generation pills and for smokers (by nine times) and women with hypertension (tenfold)
- Thus smoking and oestrogen have additive effect on the risk of arterial thrombosis
- Low dose oral contraception (less than 50 µg EE), do not increase the risk of myocardial infarction or stroke in healthy, non-smoking women regardless of age.
- Almost all myocardial infarction and strokes in oral contraceptive users occur in users of high dose products, or users with cardiovascular risk factor over the age of 35.

### Venous Thromboembolism

The combined pill is associated with a threefold increase in the relative risk of VTE. Risk is unaffected by age, smoking and duration of pill use but is higher in obese women (Body mass index BMI >30 mg/m<sup>2</sup>) and in women with a history of pregnancy induced hypertension. Combined pills containing the third generation progestogens, gestodene or desogestrel have about two fold increased risk of VTE compared with pills containing levonorgestrel. Although the reason for this difference is unclear, it is known that oral contraceptive use reduces the efficiency with which activated protein C down regulates *in vitro* thrombin formation and this phenomenon is more pronounced in women using a pill containing desogestrel rather than levonorgestrel.

### Stroke

The risk of stroke attributable to combined oral contraceptive use is small. The relative risk of haemorrhagic stroke is not increased in women under 35 years and only slightly increased in older women. The risk of ischaemic stroke is slightly increased (relative risk 1.5) and is also slightly higher in women over the age of 35 years. Smoking and hypertension increase the risk of stroke by tenfold and threefold respectively.

### Hypertension

A very slight rise in blood pressure is not uncommon and matters little. In 1 per cent of cases, there can be a sharp rise but this is more likely in women with past history of hypertension in pregnancy. Stopping the pill, which is necessary, results in return of the blood pressure to its original level within 3 months.

- COCs are contraindicated in women who have a history of idiopathic venous thromboembolism and also in women who have close family history (parents and siblings) of idiopathic venous thromboembolism. By effectively screening for the presence of smoking and cardiovascular risk factors especially hypertension in old women, we can limit any increased risk for arterial thrombosis associated with low dose pills so low dose oral contraceptives are very safe for healthy young women with no increased risk of cardiovascular events on long term use.

### Other Metabolic Effect

- A lowered tolerance to carbohydrate can result in glycosuria and this is a warning to stop medication.
- Hyperlipidaemia is rarely seen only in women who are prone for it. The newer progestogens like desogestrel are lipid friendly.
- Sometimes increase in the blood level of protein bound iodine but OCs do not affect intrinsic thyroid function and they may be used in patients who are hypo or hyperthyroid.
- Sometimes change in liver function which is not revealed by ordinary tests and is of no consequence. Occasionally, cholestatic jaundice develops and this is a contraindication for continuing the treatment.
- Oestrogen increases the cortisol binding globulin. Free and active cortisol both are increased because oestrogen decreases the ability of liver to metabolise cortisol.

### Risk of Cancer

- Endometrial Cancer:** The use of COC protects against endometrial cancer. Use for at least 12 months reduces the risk of developing endometrial cancer by 50 per cent, with greatest protective effect gained by use for more than 3 years. This protection persists for 20 or more years after discontinuation and is greatest in women at highest risk, like nulliparous and low parity women. Protection is seen with all monophasic formulations of OCs, including pills with less than 50 µg oestrogen.
- Ovarian Cancer:** Protection against ovarian cancer, the most lethal of female reproductive tract cancers, is one of the most important benefit of oral contraception. The risk of developing epithelial ovarian cancer of all the histologic types in users of OCs is reduced by 40 per cent compared with that of nonusers. This protection is seen in women who use oral contraception for as little as 3 to 6 months and increases with duration of use and continues for at least 10-15 years after stopping the medication. The protective effect of OCs is especially observed in women at high-risk of ovarian cancer.
- Cancer of Cervix:** Some studies have indicated that the risk for dysplasia and carcinoma *in situ* of uterine cervix increases with the use of COCs for more than one year. It is well recognised, that the number of partners a woman has had and age at first coitus are the most important risk factors for cervical neoplasia. Other confounding factors are exposure to human papilloma virus, smoking and use of barrier contraception (protective). These are difficult to control, so conclusions regarding cervical cancer are not definitive.

Centre for disease control and prevention concluded through a study that there is no increased risk of invasive carcinoma in COCs users and an apparent increased risk of carcinoma *in situ* is due to enhanced detection of disease (more frequent paps smear in COCs users).

In WHO study of neoplasia and steroid contraceptives, a paps smear screening bias was identified, nevertheless the evidence still suggested an increased risk of CIN with long term oral contraceptive use. It is reasonable to perform paps smear every 6 months in women using oral contraception for 5 or more years.



d. **Breast Cancer:** Current and recent use of oral contraceptives may be associated with about a 20 per cent increased risk of early premenopausal breast cancer, essentially limited to localised disease and a very small increase in the actual number of cases. This finding may be due to detection/surveillance bias and accelerated growth of already present malignancies, a situation similar to the effect of pregnancy and postmenopausal hormone therapy on the risk of breast cancer.

- Previous oral contraceptive use may be associated with a reduced risk of metastatic breast cancer later in life and possibly with a reduced risk of postmenopausal breast cancer.
- OCs do not further increase the risk of breast cancer in women with positive family histories of breast cancer or in women with proven benign breast disease.

#### Oral contraceptives and risk of breast cancer

Current users	RR = 1.24, 95 per cent C1, 1.15 – 1.33
1-4 years after stopping	RR = 1.16, 95 per cent, C1, 1.08 – 1.23
5-9 years after stopping	RR = 1.07, 95 per cent, C1, 1.02 – 1.13

Even though the data indicated that young women who begin use before age 20 have higher relative risks of breast cancer during current use and in the 5 years after stopping, this is a time period when breast cancer is very rare and thus, there would be little impact on actual number of breast cancers.

e. **Liver Adenomas and Liver Cancer:** Hepatocellular adenomas can be produced by steroids both the oestrogen and androgen families. The adenomas are not malignant; their significance lies in the potential for haemorrhage. The most common presentation is acute right upper quadrant or epigastric pain. This may be asymptomatic or may present suddenly with haemoperitoneum. The risk appears to be related to duration of oral contraceptive use and to the steroid dose in the pills. This is reinforced by the rarity of the condition ever since low dose pills became available.

No reliable screening test or procedure is currently available. Routine liver tests are normal. Palpation of the liver should be a part of the periodic evaluation in OCs users. If an enlarged liver is found, oral contraception

should be stopped and regression should be evaluated followed by imaging.

There is no evidence of an increased risk of liver cancer in oral contraceptive users.

#### Fertility and Oral Contraception

There is no evidence that infertility is increased by the use of oral contraception. In fact, in young women previous oral contraceptive use is associated with a lowered risk of primary infertility. Ovulation returns to normal within 3-6 months of stopping oral contraceptive pill and 90 per cent become pregnant by 24 months.

Women who become pregnant while taking oral contraceptives or inadvertently take birth control pills early in pregnancy should be advised that the risk of significant congenital anomaly is no greater than the general rate of 2-3 per cent.

#### Breast Feeding

Oral contraception has been demonstrated to diminish the quantity and quality of lactation in postpartum period. Also of concern is the potential hazard of transfer of contraceptive steroids to the infants, however, no adverse effects have thus far been identified.

#### Breakthrough Bleeding

- A major continuation problem is breakthrough bleeding. On start of OCs, patient need to be fully informed about breakthrough bleeding.
- The most frequently encountered breakthrough bleeding occurs in the first few months of use (1st 3 months) ranging from 10-30 per cent in the first month to less than 10 per cent in the third. It is higher with the lowest dose oral contraceptive pills (with formulations containing 20 µg of ethinyl oestradiol) and smoking.
- It is best managed by encouragement and reassurance; this bleeding usually disappears by 3rd cycle in majority of women. It is helpful to explain to the patient that this bleeding represent tissue breakdown as the endometrium adjusts from its usual thick state to a relatively thin state allowed by OCs.
- Breakthrough bleeding that occurs after many months of OCs use is a consequence of the progestin induced decidualisation; this endometrium and blood vessels tend to be fragile and prone to breakdown and asynchronous bleeding.

- Cervical infection can be another cause of breakthrough bleeding; the prevalence of cervical chlamydial infections is higher among oral contraceptive users who report breakthrough bleeding.
- If breakthrough bleeding is prolonged or if it is aggravating for the patient, regardless of the point in the cycle, control of the bleeding can be achieved with a short course of exogenous oestrogen, conjugated oestrogen 1.25 mg or oestradiol 2 mg daily for 7 days, no matter where the patient is in her pill cycle. The patient continues to adhere to the normal schedule of pill taking. If recurrence does occur (usually does not occur) repeat course of oestrogen for 7 days can be given.
- The addition of extra oestrogen while keeping the progesterone dose unchanged is logical and effective. This allows the patient to remain on the low dose formulation with its advantage of greater safety. Any bleeding that is not handled by this routine requires investigations for the presence of pathology.

### Amenorrhoea

The incidence of amenorrhoea in the first year of use with low dose contraception is less than 2 per cent. This incidence increases with duration, upto 5 per cent after several years of use. It is important to give information to the patient upon starting oral contraception that diminished bleeding or no bleeding may ensue on using oral combined pills.

This is more with low dose OCs, oestrogen content is not sufficient in some women to stimulate endometrial growth. The progestational effect dominates to such a degree that a shallow atrophic endometrium is produced, lacking sufficient tissue to yield withdrawal bleeding.

It should be emphasised that permanent atrophy does not occur and resumption of normal ovarian function which restore endometrial growth and development occurs within few months.

### Management

- Reassurance to the pill user
- A pregnancy test for the presence of pregnancy even at this early stage
- Assess basal body temperature during the end of pill free week. BBT less than 98°F is not consistent with pregnancy.

- Sometimes, addition of extraoestrogen for 1 month (1.25 mg conjugated oestrogen or 2 mg ethinyl oestradiol for 21 days) while taking the oral contraceptive pills. It will rejuvenate the endometrium and withdrawal bleeding will resume.

### Migraine Headaches

Oral contraceptive should be avoided in women who have migraine with complex or prolonged aura or if additional stroke factors are present (older age, smoking, hypertension)

Prior studies with high dose pills indicated that migraine were linked with a risk of stroke but recent studies with low dose pills yield mixed results.

- So if the patient is on higher dose, change to low dose formulations, may relieve the headaches.
- Women who experience an exacerbation of their headache with oral combined pills should consider one of the progestin only method.

#### **Severe vascular headache is identified if:**

- Headache lasts for long time
- Headache with nausea, vomiting and dizziness
- With blurred vision or scotomata
- Episodes of blindness
- Unilateral, unremitting headaches
- Headache that continue despite medication

### Drugs that Affect Efficacy

Drugs, which stimulate the liver's metabolic capacity, can affect oral contraceptive efficacy. Patient on medications that affect liver metabolism should choose an alternative contraceptive. These drugs are as follows:

- Rifampicin
- Phenobarbital
- Phenytoin
- Primidone
- Carbamazepine

#### *Possibly:*

- Ethosuximide
- Griseofulvin
- Troglitazone

### The Benefits of Low Dose Oral Contraceptive Pills

- Effective contraception
  - Less need for induced abortion
  - Less need for surgical sterilisation

- Less endometrial cancer
- Less ovarian cancer
- Fewer ectopic pregnancy
- More regular menstrual flow less flow
  - Less dysmenorrhoea
  - Less anaemia
- Less salpingitis
- Less anaemia
- Probably less endometriosis
  - Less benign breast disease
  - Less rheumatoid arthritis
  - Fewer fibroid
  - Fewer ovarian cyst
  - Protection against atherosclerosis

### Other Uses

Oral contraceptives are frequently utilised to manage the following problems and disorders:

- Dysfunctional uterine bleeding
- Dysmenorrhoea
- Mittelschmerz
- Endometriosis prophylaxis
- Acne and hirsutism
- Hypothalamic amenorrhoea
- Prevention of menstrual porphyria
- Control of bleeding (dyscrasias, anovulation)
- Some times used for
  - Functional ovarian cyst
  - Premenstrual syndrome

For patients having anovulatory dysfunctional uterine bleeding and need effective contraception, oral contraceptives are a good choice. OCs are also a good choice to provide prophylaxis against the recurrence of endometriosis. To protect against endometriosis, oral contraceptives should be taken daily with no break and no withdrawal bleeding.

OCs have long been used to speed the resolution of ovarian cysts but the efficacy of this treatment has not been established.

### Technique

**History:** A full history including family history and past history should be taken to exclude risk factors that might contraindicate COCs or indicate other investigations.

**Examination** — Blood pressure  
— Baseline weight

- BMI  $>30 \text{ kg/m}^2$  is considered a relative contraindication and BMI  $>35 \text{ kg/m}^2$  is an absolute contraindication because of increased risk of VTE
- Pelvic examination
- Breast examination
- Cervical smear

### Choice of Preparation

1. New users should usually start with a low dose pills containing second-generation progestogens.
2. If breakthrough bleeding occurs and persist beyond the first three months and gynaecological causes are excluded, a pill containing higher dose of oestrogen or different progesterone should be started.
3. Women on long-term enzyme inducing drugs (Phenytoin and Rifampicin) should use a  $50 \mu\text{g}$  oestrogen preparation to ensure best efficacy.
4. The patch should be considered if nausea or vomiting is a persistent side effect.
5. The patch can also be used in women who have difficulties in remembering to take a pill every day.

### Information

- Women should be carefully instructed how to use the pill and what to do when pills are forgotten. Show and demonstrate to the patient the package of pills she will use.
  - Explain how oral contraception works.
  - Review briefly the risk and benefits of oral contraception but also emphasise the safety and non-contraceptive benefits of low dose OCs.
  - Explain how to take the pills.
  - Explain the warning signs of potential problems e.g. abdominal or chest pain, troublesome breathing, severe headaches, visual problems, leg pain or swelling.
  - Ask if the patient has any question and to call if another clinician prescribes other medications.
  - Schedule a follow up in 1-2 months to review understanding and address fears and concerns.
  - Ask the patient to call for any problem or concern before she stops taking the OCs.
- All this information is essential to improve the continuation rate of OC pill users.

### Contraceptive Patch (EVRA)

Only one contraceptive patch is currently available. The combined contraceptive patch looks like a square band-aid, 20 cm<sup>2</sup> in size. EVRA delivers 20 µg EE and 150 µg norelgestromin (17-decacyl norgestimate) daily. It is applied to the abdomen, buttock or upper arm and deliver hormones through skin.

#### Use

- To start, it is applied within first 5 days of menstruation or after a first trimester abortion.
- The day of the week, used to apply the patch, the same day it should be changed one week later.
- Use one patch per week for three weeks consecutively with a placebo patch or patch free interval in week four, when withdrawal bleeding occurs.
- Contraceptive protection last for upto 10 days, allowing for error in changing the patch.

#### Missed Patch Changes

1. Forget to change a patch at the beginning of a cycle, apply one as soon as you remember and record this day as your new patch change day and use a back up method of birth control for next 7 days.
2. In the middle of cycle — put a new patch as soon as possible and use backup method for 7 days.
3. If forgotten to remove the third patch in the cycle, remove it as soon as possible and no need to change your next regular patch change day or no need of back up method.

#### Efficacy

- The overall pearl index for the patch was 1.24/100 women years (HWY) of use in a one randomised trial.
- Advantages and disadvantages are almost same as OC pills. It is easy to use and does not cause nausea or vomiting.

### Combined Contraceptive Vaginal Ring (Fig. 50.16)

- Nuvaring releases 15 µg EE and 120 µg etonogestrel per day and is recently introduced in Europe.
- The ring is made of soft ethylene vinyl acetate copolymer and measures 54 mm in diameter.
- It is designed to last for 3 weeks; a 7 days ring free interval is associated with bleeding patterns, which appear superior to those of COCs.



Fig. 50.16: Contraceptive Vaginal Ring

- Advantages, disadvantages and efficacy are same as OC pills.

### Combined Injectable Contraceptive (LUNELLE)

- Lunelle is a once a month injectable contraceptive containing 25 mg medroxyprogesterone acetate and 5 mg oestradiol cypionate.
- It is administered intramuscularly every 28 days interval.
- Bleeding episodes occur 18-22 days after injection when oestrogen concentration falls to around 50 µg/ml or less. Approximately 70 per cent of women experience one bleeding episode per month.
- It does requires monthly visit to a clinic.
- It is only available in some parts of the world although not in the UK.

### Progestogen Only Contraception

Progestogen only contraceptive is now available, with the active hormone administered as oral preparations, injectables, implants or intrauterine systems.

#### Indications

1. Women with medical illness contraindicating the use of combined pills e.g. hypertension, migraine with focal aura, diabetes or personal history of venous thromboembolism.
2. Breastfeeding women

3. Women who are at increased risk of venous or arterial disease with COC (obese and heavy smokers)
4. Women who have oestrogenic side effects with COCs e.g. headache, breast tenderness.
5. Women who specifically choose for this method.

**Contraindications**

- Known or suspected pregnancy
- Active venous thromboembolic disorder
- Past or current severe arterial disease
- Presence of severe hepatic disease
- H/O pregestogen dependent tumours
- Recent trophoblastic disease until serum  $\beta$  HCG is undetected
- Undiagnosed vaginal bleeding
- Hypersensitivity to progestogen

**Progestogen Only Pills (POPs) (Minipill)**

The minipills contain a small dose of a progestational agent and must be taken daily in a continuous fashion.

Types of progestogen contained in minipill:

Type of Progestogen	Dose	Commercial Name
Desogestrel	75 $\mu$ g	Cerazette®
Levonorgestrel	75 $\mu$ g	Ovrette, Neogest
Norgestrel	30 $\mu$ g	Microval, microlut
Norethistrone	350 $\mu$ g	Noriday, Micronor
Lynestrenol	500 $\mu$ g	Exluton
Ethinodiol diacetate	500 $\mu$ g	Femulen

**Mode of Action**

- It mainly acts by altering the cervical mucus to reduce the sperm penetration (thick and impermeable).
- It induces changes in the endometrium to prevent sperm survival and becomes hostile to implantation.
- Ovulation may be suppressed in 15-40 per cent of cycles and only partly contributes to the mechanism of action.
- Ectopic pregnancy is not prevented as effectively as intrauterine pregnancy, although the overall incidence of ectopic pregnancy is not increased. However when pregnancy occurs, we must suspect that it may be an ectopic.

**Efficacy**—Failure rates of the POP vary from 1.1 to 9.6 per 100 women in the first year of use.

Failure rate is higher in younger women (3.1/100 women years) compared with women around 40 years of age (0.3 per 100 women years).

A POP containing 0.75  $\mu$ g desogestrel however inhibits ovulation in 97-99 per cent of the cycles, resulting in efficacy similar to combined oral pills.

**Pill Taking**

The minipill should be started on the first day of menses or it can be taken with the first 5 days of menstrual cycle, as no extra contraceptive precautions are required. It then needs to be taken daily with no breaks, at the same time of the day.

1. If pills are forgotten or gastrointestinal illness impairs absorption, the minipill should be resumed as soon as possible and a back up method should be used immediately and until the pills have been resumed for at least 2 days.
2. If two or more pills are missed in a row and there is no menstrual bleeding in 4-6 weeks, a pregnancy test should be done.
3. If more than 3 hours late in taking a pill, a backup method should be used for 48 hrs.

**Side Effects**

- Irregular bleeding being the most common cause leading to discontinuation in 22.5 per cent of women.
- Headache 7.5 per cent of women
- Acne 3.1 per cent more with levonorgestrel minipill
- Breast pain 4.0 per cent
- Nausea mild 3.3 per cent
- Vaginitis 3.8 per cent
- Dysmenorrhoea 1.2 per cent
- **Bone mineral density:** There is little concern that POP has an adverse effect on BMD, even in amenorrhoeic women as oestradiol levels are well within the normal range.

**Progesterone Only Injectables**

- Depoprovera (depo medroxyprogesterone acetate) is the most commonly used injectable progesterone only contraceptive, which has been used extensively worldwide.
- Depoprovera comes as a microcrystals, suspended in an aqueous solution. The correct dose for contraceptive purpose is 150 mg intramuscularly (gluteal or deltoid) every 3 months. Contraceptive level is maintained for at least 14 weeks. Women may occasionally attend late for their injection and no action needs to be taken until 14 weeks have elapsed.

The other progestogen only injectable is Noristerat. This contains 200 mg norethisterone enantate (NET-EN), given intramuscularly at every 8 weeks interval (2 months). NET-EN is used mainly for a women whose husband is undergoing vasectomy, until the vasectomy is effective and in women immunised against rubella, to prevent pregnancy during the activity of virus. NET-EN can be used for long term contraception in selected patients after counselling.

### *Mechanism of Action*

- Depoprovera is not a sustained release system, it relies on higher peaks of progestins to inhibit ovulation and thicken cervical mucus.
- It inhibits ovulation by effectively suppressing LH surge. FSH suppression is not as intense as with COC, therefore follicular growth is maintained sufficiently to produce oestrogen levels comparable to early phase of normal menstrual cycle. So symptoms of oestrogen deficiency like vaginal atrophy or decrease in breast size do not occur.
- The injection should be given within the first 7 days of current menstrual cycle, otherwise a backup method is necessary for 1 week. It should be given deeply in muscle by Z track technique and not massaged.

### *Indications*

1. Breast feeding mothers
2. Sickle cell disease
3. Seizure disorder
4. Oestrogen free contraception needed
5. Coitally independent method desired

### *Contraindications*

1. Pregnancy
2. Unexplained genital bleeding
3. Severe coagulation disorder
4. Previous sex steroid induced hepatic adenoma
5. Liver disease
6. Severe cardiovascular disease
7. Difficulty with injection

### *Efficacy*

DMPA and NET-EN are almost as effective as COCs. Pregnancy rates at one year for DMPA is around 0.3 per

100 women and for NET-EN, it is 0.4 per 100 women years of use on the usual regimen.

### *Side Effects*

Major problem with depoprovera is irregular menstrual bleedings or amenorrhoea. NET-EN has less effect on bleeding pattern than DMPA. The incidence of irregular bleeding is 70 per cent in the first year and 10 per cent thereafter. Bleeding and spotting decreases progressively with each re-injection so that after 5 years, 80 per cent of users are amenorrhoeic.

About 1/3rd of women discontinue depoprovera by the end of one year and 50 per cent by the second year.

Other problems are headache, dizziness, abdominal pain and anxiety. Whether DMPA causes these side effects is difficult to know since they are very common complaints in nonusers as well.

If necessary, the bleeding can be treated with exogenous oestrogen, 1.25 mg conjugated oestrogen or 2 mg oestradiol, given daily for 7 days. A nonsteroidal anti-inflammatory product given for a week is also effective and another option is to administer an oral contraceptive for 1-3 months.

Return of fertility may be delayed after stopping use of progestogen only injectable. However, almost 70 per cent of former DMPA users had conceived within the first 12 month of discontinuation and over 90 per cent had conceived within 24 months. The delay to conception is about 9 months after last injection and the delay does not increase with increasing duration of use. Suppressed menstrual function persisting beyond 12 months after the last injection is not due to the drug and deserves evaluation.

### **Bone Mineral Density (BMD)**

In November 2004, as a result of new evidence, the committee on safety of medicines released guidance on the use of DMPA.

- In adolescents, depoprovera may be used as a first line contraception but only after other methods have been discussed with the patient and considered to be unsuitable or unacceptable.
- In women of all ages, careful re-evaluation of the risks and benefits of treatments should be carried out in those who wish to continue use for more than 2 years.
- In women with significant lifestyle and medical risk factors for osteoporosis, other methods of contraception should be considered.

There is evidence to suggest that DMPA affects BMD at the hip and spine in both adults and adolescents, upto 6 per cent reduction depending on site age and duration of use. It is greatest in the first 2 years of use after which it appears to plateau.

### Other Side Effects

WHO data suggests there is no long term increase in the risk of breast, cervical or ovarian cancers in DMPA users and infact marked reduction in risk for endometrial cancer.

### Progestogen Only Implants (Norplant)

Norplant is a sustained release system using silastic tubing permeable to steroid molecules to provide stable circulating levels of synthetic progestin over years of use. Norplant was first introduced into clinical trials in Chile in 1972.

Norplant was the first contraceptive implant system launched worldwide and is highly effective reversible contraceptive lasting for 5 years. It is a subdermal implant system, which is low dose progestogen only method of contraception. It consists of six small, flexible sealed silastic capsules, each measuring 34 mm in length with a 2.4 mm outer diameter and containing 36 mg crystalline levonorgestrel. The cavity of the capsule has an inner diameter of 1.57 mm, with an inner length of 30 mm. The six capsules contain a total of 216 mg levonorgestrel, which is very stable and has remained unchanged in capsules examined after a year of use. It comes in heat sealed pouches that have a shelf life of 5 years from the

date of manufacturing. It should be stored in a cool dry area away from direct sunlight. It releases 85  $\mu\text{g}$  of hormone per day initially, then decreasing to 50  $\mu\text{g}$  per day by 6 months and 35  $\mu\text{g}$  per day by 18 months.

### Mechanisms of Action

The levonorgestrel diffuses through the wall of the tubing into the surrounding tissues where it is absorbed by the circulating system and distributed systemically, avoiding an initial high level in circulation as with oral or injectable steroids. Within 24 hrs of insertion, plasma concentration of levonorgestrel ranges from 0.4 to 0.5  $\mu\text{g}/\text{ml}$ , high enough to prevent conception.

Body weight affects the circulating levels of LNG. The greater the weight of the user, the lower the LNG concentrations at any time during Norplant use. But even for heavy women, the release rate is high enough to prevent pregnancy at least as reliably as oral contraceptives.

Norplants work in a similar way as the other progestogen only contraceptives.

1. The levonorgestrel suppresses both the hypothalamus and the pituitary. The LH surge necessary for ovulation is suppressed in approximately 50 per cent of cycles. In those cycles that are ovulatory, there is a high incidence of luteal insufficiency.
2. The cervical mucus thickens and decreases in amount, forming a barrier to sperm penetration.
3. The levonorgestrel suppresses the oestradiol induced cyclical maturation of endometrium and causes atrophy. These changes prevent implantation.

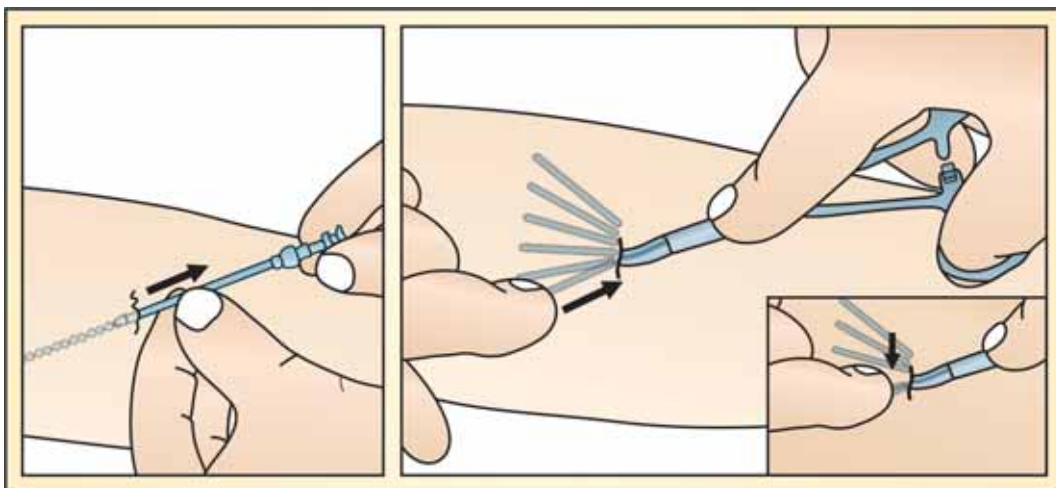


Fig. 50.17: Subdermal norplant implant

### *Insertion*

The implants are inserted subdermally on the inner aspect of the left upper arm under local anaesthesia after proper counselling and written consent.

### *Efficacy*

The overall pregnancy rate after 5 years of use is 1.1 per 100 women year and 0.2/HWY after 2 years of use.

Heavier women (>70 kg) may experience slightly higher pregnancy rates in the fourth and fifth years of use compared with lighter women.

### *Advantages*

1. It is a sustained release method with a high degree of efficacy.
2. There are no forgotten pills, broken condoms or lost diaphragm. It is not a coitus related method.
3. It is an excellent choice for breastfeeding women and can be inserted immediately postpartum but at least a 3 day postpartum delay is recommended to allow the decline in pregnancy levels of oestrogen and progesterone and the establishment of lactation.
4. Norplant use has not been associated with changes in carbohydrate or lipid metabolism, coagulation, liver and kidney function or immunoglobulin level.
5. It allows women to plan their pregnancies precisely; return of fertility after removal is prompt in contrast to 18 months delay in ovulation that can follow depoprovera injection.

### *Disadvantages*

1. Norplant causes disruption of bleeding patterns in upto 80 per cent of uterus especially during the first year of use. Endogenous oestrogen is nearly normal and but progestin is not regularly withdrawn to allow endometrium shedding. Consequently, the endometrium sheds at unpredictable intervals.
2. It needs a surgical procedure performed by a trained personnel for insertion and removal. Women cannot initiate or discontinue the method without the assistance of a clinician. As it requires a surgical procedure, initiation and discontinuation costs will be higher than with oral contraceptives or barrier methods.
3. It can be visible under the skin; this may be unacceptable by some women.

4. It does not protect against STDs, users at risk should use barrier method to prevent infection.

### *Indications*

1. Desire a highly effective, long term method of contraception.
2. Experience serious or minor side effects with OCs.
3. Have completed child bearing but do not desire permanent sterilisation.
4. Those who do not want to use other methods.
5. Women with chronic illnesses.
6. Have history of anaemia with heavy menstrual bleeding.

### *Contraindications*

- Active thrombophlebitis
- Undiagnosed genital bleeding
- Acute liver disease
- Benign or malignant liver tumour
- Known or suspected breast cancer.

### *Side Effects*

The occurrence of serious side effects is very rare.

1. The most common side effect experienced by users is headache; approximately 20 per cent of women who discontinue use, do so because of headache.
2. Weight change: Women more frequently complain of weight gain than weight loss. Counselling for weight changes should include dietary review and focus on dietary changes.
3. Bilateral mastalgia occurring premenstrually is usually associated with complaints of fluid retention. After pregnancy has been ruled out, reassurance and therapy aimed at symptomatic relief are indicated.
4. Galactorrhoea is more common among women who have had insertion of the implants on discontinuation of lactation. Patient should be reassured after ruling out pregnancy and thorough breast examination should be done. If amenorrhoea accompanies galactorrhoea then a prolactin level should be obtained.
5. Acne is the most common skin complaint. It is caused by the androgenic activity of the levonorgestrel. Proper counselling, reassurance and dietary changes to maintain a good skin hygiene with the use of soaps or skin cleansers and application of 1 per cent clindamycin creams or erythromycin ointment is required.



6. Menstrual effect is highly variable, some alteration of menstrual pattern will occur during the first year in approximately 80 per cent of users, later decreasing to about 40 per cent.
7. **Ovarian Cyst:** Adnexal masses are approximately 8 times more frequent in norplant users compared with normally cycling women. Unlike OCs, low serum progesterone level maintained by norplant does not suppress FSH, which continues to stimulate ovarian follicular growth while LH peaks are usually abolished, so that these patients do not ovulate. However some continue to grow and cause pain or be palpated at the time of examination. Because these are simple cyst, most regress spontaneously within one month of detection, they need not be evaluated sonographically or laparoscopically.
8. **Ectopic pregnancy:** Rate of ectopic pregnancy during norplant use has been 0.28 per 1000 women year. Although the risk is low but if pregnancy does occur, ectopic pregnancy should be suspected, as 30 per cent of Norplant pregnancies are ectopic.

### LNG Rod

The two rod system or Norplant-2

- It uses levonorgestrel suspended in a silastic matrix and covered with a silastic membrane.
- A new system is composed of 2 levonorgestrel rods called LNG rod, encased in silicon rubber tubing, sealed at each end with silastic adhesive. Each rod measures 2.5 mm in diameter and 4.3 cm in length containing 75 mg of LNG (levonorgestrel) and release the drug, similar to Norplant.
- Performance and side effects are similar to norplant.
- Insertion and removal is easier and faster.

### Implanon

- Implanon is a single rod implant containing etonogestrel (3-Ketodesogestrel), available in UK since 1999.
- It consists of one semi rigid capsule, 4 cm long containing 68 mg etonogestrel, the active metabolite of desogestrel. The hormone is released at an initial rate of 60 µg per day decreasing to 30 µg per day after 2 years.
- Insertion and removal times are very much quicker than with Norplant.



**Fig. 50.18:** Implanon is inserted under the skin of the upper arm, providing protection against pregnancy for up to 3 years

- Implanon should ideally be fitted within the first 5 days of menstrual cycle, as no contraceptive extra cover is required.
- It is immediately reversible with more than 90 per cent of women ovulating within the first 30 days after removal.
- Implanon is designed to provide contraception for 3 years after which the implant should be removed.

### Mechanism of Action

Etonogestrel is released steadily and in controlled fashion over 3 years with no accumulation. Within one day of insertion, serum blood levels of etonogestrel (90 µg/dl) is achieved, which inhibit ovulation, and maximum level in 4 days. It also reduces the sperm penetrability of cervical mucus.

- **Bleeding pattern:** Implanon users experience less bleeding but have a more variable pattern initially. Otherwise side effects are same as those with norplant except for less bleeding and higher rate of amenorrhoea with implanon.
- Efficacy and continuation rate are similar to Norplant.

### Uniplant

Uniplant is a single implant contraceptive containing 38 mg nomegestrel acetate in a 4 cm silastic tube with a

100 µg per day release rate. It provides contraception for 1 year.

### Biodegradable Implant Contraception

It delivers sustained levels of progestins for variable period of times from a vehicle that dissolves in body tissues. The utility of this implant would be improved by the elimination of the need for surgical removal.

Two types are under evaluation :

- Capronor
- Norethindrone pellets

#### Capronor

It is a single capsule, biodegradable, levonorgestrel releasing subdermal implant composed of the polymer E-caprolactone. Implants measure 0.24 cm in diameter and either 2.5 or 4 cm in length, providing contraception for one year. The capsule remain intact for the first 12 months of use, allowing easy removal. After 12 months the capsule begins to disappear.

Capronor share the advantage of norplant with convenience of use and few metabolic side effects. Its removal is easier and quicker.

Biodegradable implants could continue to release small non-contraceptive amount of hormone after their period of use as a contraceptive has expired. Although it is unlikely that such low serum level of progestin would be harmful to users or their pregnancies, this question needs to be solved.

#### Norethindrone Pellet or Anuelle

It is injected subdermally and maintain circulating contraceptive level of progestin for upto 3 years. This pellet is composed of 10 per cent pure cholesterol and 90 per cent norethindrone and are about the size of a grain of rice. This method is currently under development.

### Progestogen Intrauterine System (MIRENA)

Mirena (Fig. 50.19) is a new intrauterine hormonal contraceptive system releasing levonorgestrel. It has been available worldwide since 1995 and more than 6 million women worldwide have used it for contraception. Nowadays, in addition to contraception, it is used for idiopathic menorrhagia, for therapeutic benefits in fibroid, adenomyosis, endometriosis and more recently as the progestogen component of hormone replacement therapy.

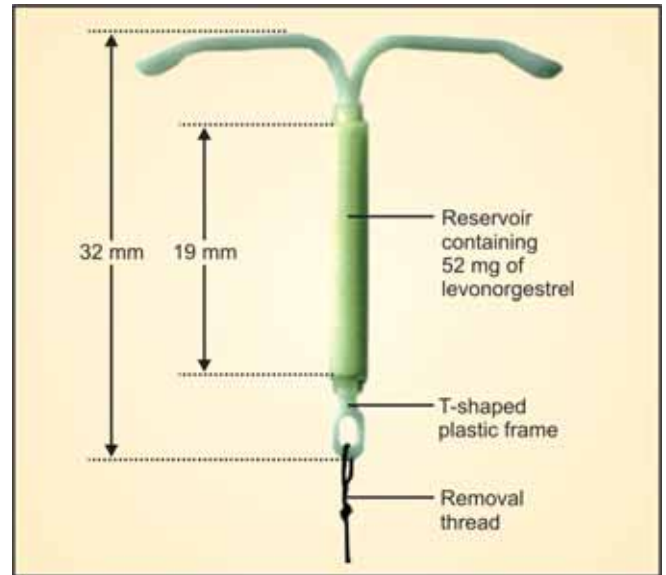


Fig. 50.19: Mirena

### Structure

Mirena consist of a plain plastic T shaped frame with a steroid reservoir around the vertical stem. This reservoir consist of a cylinder, made of LNG and polydimethylsiloxane mixture, containing a total of 52 mg LNG. The total length of the systems is 32 mm. The reservoir forms a 19 mm long sleeve around the vertical arm of the plastic body and is covered by a polydimethylsiloxane membrane, which regulates the minimal intrauterine release of LNG. T shaped frame is impregnated with barium sulphate to make it radio-opaque.

The recommended duration of use for mirena is 5 years. Thereafter it should be removed and replaced by a new system if needed.

With mirena, only 20 µg/day of LNG is released.

### Mechanism of Action

The contraceptive effect of mirena is based on local effects of LNG in the uterine cavity. These are as follows:

- Thickening of cervical mucus so that the passage of sperm and their migration is inhibited.
- Inhibition of sperm motility and function inside the uterus and the fallopian tubes, preventing fertilisation.
- It causes endometrial atrophy by making the uterine mucosa thin, stroma swollen, endometrial glands atrophic and epithelial cells inactive. So the

endometrium becomes unresponsive to oestrogen and does not undergo menstrual shedding. After removal of mirena, the endometrium returns to normal and within 30 days menstruation begins.

- **Ovarian function:** During the first year of use some women experience changes in ovarian function. After the first year, most cycles are ovulatory (around 85%).
- Serum oestradiol ( $E_2$ ) level remain normal during the use of mirena.
- Oligoamenorrhoea or amenorrhoea develops despite normal ovarian function due to endometrial atrophy.

#### *Time of Insertion*

It should be inserted within the first 7 days of the menstrual cycle when bleeding is not heavy.

#### *Efficacy*

With mirena, 1 year and 5 years pregnancy rates are 0.1 per cent and 0.5 per cent respectively and has very high continuation rate with around 82 per cent of women using it after 3 years.

#### *Indications*

1. **Contraception:** Mirena is highly effective contraceptive. It provides fertility control comparable to female sterilisation.
2. **Idiopathic menorrhagia:** It also markedly reduces menstrual blood flow and alleviates dysmenorrhoea.
3. For regression of endometrial hyperplasia.
4. It can prevent endometrial proliferation and reduce the uterine bleeding associated with oral or transdermal oestradiol.
5. Mirena may be effective for long term prevention of fibroids and also regulates the growth of fibroids. Studies are going on.

#### *Adverse Effects*

- During the first few months after insertion of Mirena recipient may experience transient hormonal side effects including oedma, headache, breast tenderness, acne or other skin problems.
- Sometimes lower abdominal or back pain, vaginal discharge and nausea.

#### **Changes in Bleeding Pattern**

A fairly predictable bleeding pattern follows insertion of Mirena. The first few months are characterised by an

increase in total bleeding days, intermenstrual spotting also sometimes occur. After the first 3 months, however, the menstrual blood loss decreases and the number of bleeding days decline. Thorough counselling and discussion before insertion will result in high continuation rate and user satisfaction.

Some 20 per cent of women end up having no monthly bleeding at all within the first year of use. Women should be reassured that the absence of bleeding is most unlikely to signify pregnancy and neither indicative of hormonal abnormality. They can be assured that a normal menstrual bleeding will return within the first month of Mirena being removed.

#### *Risk of PID (Pelvic Inflammatory Disease)*

The incidence of PID with Mirena is low, at 5 years the rate is less than 1 per 100 women years. Some studies suggest that this system offers protection against PID, may be related to the thickening of cervical mucus, endometrial suppression and reduction in the amount of bleeding.

#### *Risk of Ectopic Pregnancy*

The ectopic pregnancy rate is among the lowest of the intrauterine contraceptive method. At 5 years, ectopic pregnancy rate is around 0.02 per 100 women years. Indeed, for women aged 25-34 years and using no contraception, the expected ectopic pregnancy rate is around 7.5 to 10.6 per 1000 women years.

#### *Return to Fertility*

- Cyclical ovarian function is immediately restored after removal of mirena.
- Conception rates are normal, as high as 96 per 100 at 12 months after removal of mirena.

#### *Expulsion*

This system can be expelled without the woman noticing it or sometimes having bleeding or pain. Partial expulsion may decrease the effectiveness of mirena. Increase in menstrual blood flow may be indicative of expulsion. The women should be advised how to check mirena thread.

#### *Perforation*

It is very rare with mirena, may occur rarely most often during insertion. Then it must be removed.

### *Lost Threads*

If the retrieval threads are not visible at the cervix on follow up examination, pregnancy must be excluded. Then the thread may usually be located by gently probing with a suitable instrument. X-ray may be used to locate it. Ultrasound diagnosis may be used to ascertain the correct position of the system.

### *Delayed Follicular Atresia*

Since the contraceptive effect of mirena is mainly due to its local effect, ovulatory cycles with follicular rupture usually occur in women of fertile age. Sometimes atresia of the follicle is delayed and folliculogenesis may continue. These enlarged follicles cannot be distinguished clinically from ovarian cysts. Enlarged follicles have been diagnosed in about 12 per cent of subjects. Most of these follicles are asymptomatic, sometimes accompanied by pelvic pain or dyspareunia. In most cases, the enlarged follicles disappear spontaneously during next two to three months, ultrasound monitoring is recommended to review.

### *Insertion and Removal*

- Before insertion, woman must be informed of the efficacy, side effects and risks. Proper counselling should be done.
- A physical examination including pelvic examination, examination of breasts and a cervical smear should be performed.
- Pregnancy and sexually transmitted disease must be excluded and have to be treated.
- The position and size of uterine cavity should be determined.
- Fundal positioning of mirena is particularly important in order to ensure uniform exposure of the endometrium to the progestogen, to prevent expulsion, and maximise efficacy.
- After insertion woman should be re-examined 4-12 weeks after and once a year thereafter.
- It is inserted within seven days of the onset of menstruation, can be replaced by new system at any time in the cycle. It can also be inserted immediately after first trimester abortion. Postpartum insertion should be delayed until six weeks after delivery.
- Mirena may not be suitable for use as a postcoital contraceptive.

- Mirena is removed by gently pulling the thread with a forceps. If the thread is not visible then it may be removed using a narrow tenaculum.
- Insertion and removal may be associated with some bleeding and pain. It may precipitate fainting as a vasovagal reaction or a seizure in epileptic patients.

## **EMERGENCY POSTCOITAL CONTRACEPTION (MORNING AFTER PILLS)**

Emergency contraception is a method of contraception used before menstruation is missed as an emergency procedure, to prevent pregnancy following unprotected intercourse or expected failure of contraception. This method can be used only as an emergency measure following a single act of intercourse before the menses are missed. It cannot be used as an ongoing method of contraception because of relatively high failure rates and high incidence of irregular bleeding.

### *Indication*

1. For aged couple who meet very infrequently.
2. Following a single act of sexual exposure in young girls.
3. When pregnancy is apprehended owing to rupture of condoms, detection of defect in diaphragm after its use or premature ejaculation in couples practising coitus interruptus regularly.
4. When unprotected isolated intercourse happens at some odd moments among couples otherwise using conventional contraceptives.
5. In cases of rape and incest.

### *Advantages*

- Saves the couples from unwanted pregnancies
- From unnecessary operative interferences for fear of pregnancy
- From the agony of waiting for the next menstrual cycle
- Prevents adolescent pregnancies
- Helps to reduce unsafe abortion

Two methods of emergency contraception are available now:

1. Hormonal
2. Mechanical

## Hormonal Emergency Contraception

High doses of oestrogen were used most widely for 5 days up to the early 1970s, but most women experienced side effects particularly nausea and vomiting. This oestrogen only method has been abandoned completely.

Two types of hormonal contraceptive method are used now (a) combined oestrogen and progestogen pills, (b) levonorgestrel only pill.

## Combined Oestrogen and Progestogen Pills

Yuzpe developed a method utilizing a combined oral contraceptive, resulting in an important reduction in dosage. The following treatment regimens have been documented to be effective.

- Ovral — 2 tablets followed by 2 tablets 12 hours later
- Alesse — 5 tablets followed by 5 tablets 12 hours later
- Loovral, Nordette, Levlen, Triphasil, Trilevlen—4 tablets followed by 4 tablets 12 hours later
- Pills should be taken within 72 hours of unprotected intercourse.
- Pill 72, E.C., I-Pill are marketed in India as emergency contraceptives.

### Mode of Action

It may act through

1. Inhibition or delay of ovulation
2. Prevention of implantation in the altered endometrium

Exact mechanism of action is not known, studies are going on.

### Effectiveness

The yuzpe regimen prevents about 75 per cent of pregnancies that otherwise were expected to occur. Approximately 8 per cent of women can be expected to become pregnant after a single act of unprotected intercourse on a random day of menstrual cycle but only 2 per cent become pregnant if they use the yuzpe regimen.

### Side Effects

1. Nausea occurs in 50 per cent of users but does not last for more than 24 hrs.
2. Vomiting occurs in 20 per cent of users; if vomiting occurs within 2 hours of taking the pills, the dose should be repeated.

3. Irregular uterine bleeding – Some women may experience some spotting after taking the pills. The majority of women will have an early onset and in some, menstruation is delayed by 7 days. If there is a delay of more than 7 days, a pregnancy test should be performed.
4. Others are like headache, dizziness, fatigue and breast tenderness.

## Levonorgestrel Only pills

Levonorgestrel in a dose of 0.75 mg given twice, 12 hours apart, is more successful and better tolerated than the combined oral contraceptive method. This dose of LNG is equivalent to 20 pills of the norgestrel progestin only minipills.

In many countries, special packages of 0.75 mg levonorgestrel are available for emergency contraception.

### Efficacy

Efficacy with Levonorgestrel only method will be even better. In the worldwide WHO study, the risk of pregnancy was 60 per cent lower with LNG only method compared with the oral contraceptive method. Failure rate was only 1.1 per cent for LNG only group while it was 3.2 per cent for the yuzpe group.

**Side effects** are less with this method.

**Mechanism of action** is not known with certainty but it is believed with justification that this treatment is mainly a delay of ovulation combined with a local effect on the endometrium.

### Treatment Method

- Treatment should be initiated as soon after exposure as possible and the standard recommendation is that it should be no later than 72 hours.
- Because of the possible but unlikely, harmful effects of these high doses to a foetus, an already existing pregnancy should be ruled out prior to the use of postcoital method.
- The patient should be offered induced abortion if the method fails.
- This patient encounter also provides opportunity to screen for STDs and to discuss future contraception.
- It is worth adding antiemetic to the treatment, which should be taken one hour before EC pills. If a patient vomits within an hour, additional pills must be administered as soon as possible.

- Because of the high doses of oestrogen, emergency contraception with combined pills should not be provided to women with either a personal or close family history (parents or siblings) of idiopathic thrombotic disease.
- A 3 week follow-up visit should be scheduled to assess the result and to counsel for routine contraception.
- It does not protect against STDs and HIV.

### Mechanical Emergency Contraception

Intrauterine devices introduced postcoitally can prevent pregnancy very successfully. This method is being tried since the mid 1970s.

#### Indication

1. IUCDs are preferable if the woman desires IUCD as an ongoing method of contraception.
2. If there is contraindication to the use of oestrogen (LNG pills can also be used in these cases).

#### Advantages

1. IUCD can be used postcoitally upto 5 days following sexual exposure.
2. IUCD is effective as soon as it is inserted and therefore gives immediate protection for subsequent acts of intercourse in the same cycle.
3. It can be used as an ongoing method of contraception upto 3 to 10 years depending upon type of IUCD used.

#### Disadvantages

- Apart from the usual side effects of IUCDs like bleeding, pain and expulsion, there is chance of severe pelvic infection if the woman has vaginal infection including sexually transmitted disease or asymptomatic PID at the time of insertion.
- IUCDs do not prevent against HIV/AIDS. So the use of IUCD as an emergency contraceptive is also contraindicated in women who have had intercourse with a new partner and in victims of rape because of high risk of STDs.

#### Mechanism of Action

IUCDs act in the usual way by causing giant cell and lymphocytic infiltration and other cellular changes in the

endometrium and by damaging the blastocyst directly around the time of implantation (interception)

#### Efficacy

This method is highly effective with a failure rate of 0.1 per cent, which suggested that this method is 15 times more effective than yuzpe method (WHO 1999).

#### Others

Mifepristone (RU486) in a single dose of 600 mg is associated with markedly less nausea and vomiting and an efficacy rate of nearly 100 per cent. In a worldwide randomised trial 10 mg of mifepristone was as effective as 50 or 600 mg of Mifepristone, achieving a pregnancy rate of only 0.9 per cent and efficacy was not diminished by delaying treatment as long as five days after intercourse. It is still under trial. It can make an effective contribution to preventing unwanted pregnancies and induced abortions.

The use of Danazol (400 mg) for emergency contraception is not effective.

### Other Methods of Contraception

#### 1. Hormone Agonist and Antagonist

There is an ongoing search for methods of suppressing ovulation without using oestrogens. One possible development in this field is the synthesis of GnRh agonist and antagonists. GnRh agonists prevent FSH and LH surges. However, suppression of ovarian activity has undesirable side effects on the bone, CVS etc. and incomplete suppression lead to the consequences of unopposed oestrogen action. At the present time they may have a place in short term contraception e.g. in the breastfeeding mother.

#### 2. Mifepristone (Progesterone antagonist)

Progesterone antagonist have a greater potential for fertility regulation, Mifepristone blocks the action of progesterone on the endometrium and is used in emergency contraception. Daily doses of 2 mg and weekly doses of 100 mg are effective in inhibiting ovulation. Development of once a month pill given in luteal phase is also under consideration (WHO 1994).

#### 3. Centchroman

To avoid bad effects of OCs, centchroman has been produced by the researchers of Central Drug Research

Institute, Lucknow, India. It is a non-hormonal chemical synthetic once a week oral contraceptive. It is available freely in the Indian market at a relatively low cost. Each tablet contain 30 mg of centchroman. The recommended dose is one tablet twice a week starting from the first day of menses for the first 3 months and then once a week irrespective of menstruation. It was a weak oestrogen and potent antioestrogenic effect, acting mostly on the endometrial target organ to suppress proliferation of endometrium. It does not produce hormonal side effects. Sometimes causes (10% of cases) prolonged periods and prolonged cycle. Clinical trials by ICMR have shown failure rate of 20 per cent, equal to failure rates of spermicides, vaginal barrier method. Among Indian women this method is very popular.

### Immunological Method

- Effort to make a woman infertile by vaccinating her with semen to produce antibodies have so far failed. A vaccine against part of the  $\beta$  subunit of LNG has been developed which can be effective for 6-12 months but has significant local reaction. In India, a vaccine against the whole  $\beta$  subunit has been developed. It cross reacts with LH, but there is no significant menstrual disturbance. However the duration of effectiveness and long term safety has not yet been established.
- Vaccine against the zona pellucida are effective in animal studies but in animals they lead to permanent ovarian dysfunction, sterility and premature menopause.

### Male Contraceptive Pill

A reversible method of contraception for men has been sought for years. Hormonal contraception for men is inherently a difficult physiologic problem because, unlike cyclic ovulation in women, spermatogenesis is continuous, dependent upon gonadotrophin and high levels of intratesticular testosterone. Investigational approaches to inhibit production of sperm include the administration of gossypol, a derivative of cotton seed oil, sex steroids and the use of GnRh analogues.

The **sex steroids** reduce testosterone synthesis, which leads to loss of libido and development of female secondary sexual characteristics. Furthermore, despite the use of large doses, sperm counts are not adequately reduced in all subjects. Levonorgestrel, cyproterone

acetate and medroxyprogesterone acetate all have been studied, combined with testosterone, given intramuscularly to provide the desired systemic androgen effects.

**GnRh analogues** also decrease the endogenous synthesis of testosterone and supplemental testosterone must be provided. The overall metabolic and health consequences of these approaches have not been assessed and frequent injections are required.

**Gossypol** effectively decreases sperm counts to contraceptive levels, apparently by incapacitating the sperm producing cells. Gossypol pills are taken daily for 2 months until sperms are no longer observed in the ejaculate and then the pills are taken weekly. Fertility returns to normal 3 months after discontinuation. Although the experience in China has been largely positive, animal studies in U.K. indicate that gossypol or contaminants of the preparation are toxic. Analogues of gossypol may offer potential, but are years away from development.

### Choice of Contraception

The choice of contraceptive method depends on the circumstances in which it is applied and on its acceptance by the patient. The acronym 'GATHER' is used to refer to the process of counselling for contraceptive use.

G — Greet the client

A — Ask the client about herself

T — Tell the client about choices available

H — Help the client to make an informed choice

E — Explain fully how to use the chosen method

R — Return visit should be encouraged

Eventually, the choice of contraceptive is a very personal one.

### Postpartum Choice of Contraception

Additional contraception is necessary during lactation for most women. After 3 months the first ovulation can precede the first menstrual bleed. Contraception is usually on the mind of both clinician and patient at the first postpartum visit.

The Rule of 3's

- In the presence of full breastfeeding, a contraceptive method should be used beginning in the 3rd postpartum month.
- With partial and no breastfeeding, a contraceptive method should begin during the 3rd postpartum week.

- After the termination of pregnancy of less than 12 weeks, oral contraception can be started immediately.
- After a pregnancy of 12 or more weeks, the 3rd postpartum week rule should be followed. This delay has been based on a theoretical concern over an increased risk of thrombosis early in postpartum period.

### Oral Contraception

In postpartum period, because of the concerns regarding the impact of combined oral contraceptives on breastfeeding, a useful alternative is to combine the contraceptive effect of lactation with the progestogen only minipill, as there is no evidence of any adverse effect on breastfeeding as measured by milk volume and infant growth and development. Progestin only minipill even provides a modest boost to milk production and helps to breastfeed longer. In addition, minipill can protect against the bone loss associated with lactation.

Because of the slight positive impact on lactation, the minipill can be started soon after delivery, but at least a 3 day postpartum delay is recommended to allow the decline in pregnancy levels of oestrogen and progesterone and the establishment of lactation.

- Those who insist for **low dose** OC pills, the full breast feeder should begin during the 3rd postpartum month, all others during the 3rd postpartum week.
- **Depoprovera** can be administered immediately postpartum and certainly should be utilised no later than the 3rd postpartum week. Depotprovera should be used with caution in all women with previous gestational diabetes.
- **Barrier Methods:** Barrier methods have no impact on breastfeeding and they are excellent choice for motivated couples. Condoms, spermicides and foam should be used in the immediate postpartum period and use of the sponge, cap or diaphragm can be started around the 6th postpartum week.

### Postpartum IUCD

- Cu IUCDs can be inserted between 4 and 8 weeks postpartum without an increase in pregnancy rates, expulsion, uterine perforation or removal for bleeding and or pain. Expulsion rate is less with new IUCDs.
- Insertion can even occur immediately after a vaginal delivery if no intrauterine infection is present or

suspected. A slightly higher rate of expulsion is to be expected, compared to insertion 4-8 weeks postpartum.

- Insertion of an IUCD in breastfeeding women is relatively easier and is associated with a lower removal rate for bleeding or pains, perforation rate is not more.
- An IUCD can be inserted immediately after a first trimester abortion but after a second trimester abortion, it is recommended to wait until uterine involution occurs.

### Adolescent's Choice of Contraception

Providing contraception or information about contraception for young people under age 20 is an important factor. Teenage girls carry the burdens of unprotected sexual activity like unwanted pregnancy, undetected STDs and pelvic inflammatory disease. Rates of HIV infection are rising faster in young women than in any other group. Premature parenthood and the STDs are the risks of sexual experimentation.

Contraceptive education must be combined with an emphasis on overall life issues and interventions including decision to become sexually active, no single message or approach by itself will be broadly effective for all adolescents.

1. Our goals are to promote abstinence among teenagers who are not yet ready to cope with sex and its consequences and to promote behaviour that will prevent pregnancy and STDs in sexually active adolescents.
2. Building trust and good communication are requirements for a successful interaction between clinician and adolescent.

### Choice of Methods

- a. **Oral Contraception:** The combined oral contraceptive is the most popular and most requested method of contraception by teenagers. OCs are almost never medically contraindicated in healthy adolescents. Thus, the high efficacy of COC is an excellent choice for teenagers.
  - Because younger women change partners more frequently than older ones, a dual approach is recommended, COCs combined with the use of barrier methods so that they can prevent PID, STDs and HIV.



- b. **Barrier Methods:** After oral contraception, the condom use with a spermicide is the next best choice for young women obviously this is the only choice for male adolescents. The Diaphragm and cervical caps should be reserved for very motivated and young people.
- c. **Intrauterine Device:** IUCDs have not been recommended for nulligravid women and those who have a high risk of STDs. It can be considered for young parous woman who is in stable monogamous relationship. It is also a good choice for patients with chronic illness such as diabetes mellitus or SLE.
- The creams, foams, suppositories and jellies are not ideal for adolescents. They require proper timing, careful placement and consistent use to achieve good efficacy.
  - There are special candidates to consider for long acting contraception (depoprovera or Norplant), teens who have failed oral contraception and who are mentally retarded or have chronic illnesses.
  - Because adolescents often have unplanned sexual intercourse, access to emergency post coital contraception is very important. The failure rate is approximately 2 per cent using OC Pills and 1 per cent using LNG pills.
- The oral contraceptives that contain 20 µg oestrogen provides effective contraception, improves cycle regularity, diminishes bleeding and relieves menopausal symptoms.
  - Transition from oral contraception to postmenopausal hormone therapy: It is very important to change because even with lowest oestrogen dose oral contraceptive available, the oestrogen dose is four fold greater than the standard postmenopausal dose. With increasing age, dose related risks with oestrogen become significant. To establish the onset of postmenopausal years, FSH level is measured yearly beginning at age 50, sample is taken on day 6 or 7 of pill free week. When FSH is greater than 20 IU/L, it is time to change to a postmenopausal hormonal therapy.
  - Long acting methods are especially advantageous for smokers and for women with a history of thromboembolic disease.
  - IUCD (Cu and LNG IUCDs) are amongst the most effective contraception for older women, as they are more likely to be mutually monogamous and less likely to develop PID as they have already had their children.

### Contraception Choice for Older Women

1. Oral contraception
 

Oral contraceptive benefits to be emphasised with older women

  - Less endometrial cancer
  - Less ovarian cancer
  - More regular menses
  - Increase in bone density and others mentioned before
  - In all women >35 yrs of age, non-smoker, lowest dose oestrogen (20 µg) combined pills should be used.
  - The progestin only minipill is a good choice for older woman especially in whom combined pills are contraindicated.

### Contraception and Litigation

Clinicians are concerned about the prospect of bad outcomes associated with contraceptive use leading to litigation. Actually these events are very unusual compared with the widespread use of contraception. Patients who sue usually claim there were contraindications or risks that were not conveyed by clinician. The best way to avoid litigation is good patient communication and keeping good records.

- Document that the risks and benefits of all methods were discussed.
- Document a plan for follow-up.
- Document all interactions with the patient, including phone calls.

# Sterilisation and Termination of Pregnancy

Sterilisation	824
Termination of Pregnancy	830

## STERILISATION

### Definition

Sterilisation is a procedure which destroys the procreative function, and the effect is usually permanent. It can apply to either the male or female partner. Many treatments for pelvic disease (for example, hysterectomy for leiomyomas, bilateral salpingectomy for salpingitis and radiotherapy for cancer) have an incidental sterilising effect, but the term sterilisation is generally restricted to those cases in which destruction of reproductive function is the primary purpose of the treatment.

### Legal Position

An operation for purposes of sterilising either the male or female is legal, irrespective of whether the indications are medical, social or genetic, provided that full and valid consent is obtained from the person concerned. In practice it is wise but not essential in the case of a married couple to obtain the consent of the spouse also. The age at which consent to sterilisation can be given by a person varies from country to country.

### Indications

The strictly medical indications are similar to those for contraception. To justify sterilisation, however, the condition should be one which is permanent and unlikely ever to be cured or improved sufficiently to allow pregnancy with safety. As medical knowledge and skill grow, the place of sterilisation changes. As one indication disappears, heart disease amenable to surgery for example, another takes its place, high parity for example.

The indications for sterilisation cannot be defined exactly; each case must be judged on its merits and it is necessary to take cognisance of mental as well as physical health. Nevertheless, the procedure should not be recommended or undertaken lightly because it may be irreversible and the woman or man may later change their minds. Tubal ligation with a third caesarean section may seem reasonable at the time but what if the woman later remarries, or if her children die? The woman who is sensitised to the rhesus factor and has had a series of stillbirths

may be glad to be sterilised, until she finds herself a widow and about to marry a rhesus-negative man. In any case, some women (and their husbands) like to know that they could have more children if they wished, even if they regard their family as complete.

#### *Permanent Ill Health of The Potential Mother*

Any form of permanent ill health qualifies for consideration. When the indication is mental rather than physical disease, caution is necessary and the opinion of a psychiatrist should be obtained.

#### *Permanent Ill Health of The Potential Father*

This indication calls for sterilisation of the man, but not of his wife even if she asks for it.

#### *Diseases and Genetic Faults Transmissible to The Foetus*

These include mental disorders and other defects which show a strong familial or inherited tendency. Because of the increased chance of their babies being malformed, as well as other considerations, women more than 35 years of age may be sterilised on request.

#### *Previous Obstetrical Complications and Operations*

The decision to carry out sterilisation is often influenced by the opportunity offered in the course of an operation for another purpose, when it can be done without materially increasing a risk already present. In practice, a common indication is repeat caesarean section, the tubes being divided when the baby has been delivered. Nevertheless, if the baby happens to be delivered dead, or at risk, it is often wise to omit the sterilisation procedure, despite the patient's previous decision. It is customary to offer sterilisation at the time of the third section only because of a general view that it is unreasonable to expose a woman to more than three major operations. The decision, however, must vary with individuals and there are many women who have four, five, six or seven caesarean sections. The largest recorded number in one woman is 15.

#### *Family Limitation*

High parity alone is a common indication for sterilisation. It is proper to advise or agree to tubal ligation after the fourth pregnancy, if only because further childbearing

carries increased hazards. Nevertheless, many women request tubal ligation after two or three babies and, having married early, may then be only 20-25 years old. In such circumstances proper counselling is necessary because children may die or the woman may remarry.

The technique should be one that is capable of being reversed and not one which destroys the tubes over a wide area or removes the fimbriated ends of the fallopian tubes.

#### *Population Control*

Sterilisation, of the male rather than the female, is being increasingly advocated for purposes of population control. However, an impossibly large number of surgeons and operating facilities are required if male (or female) sterilisation is to have any real impact on countering a population explosion.

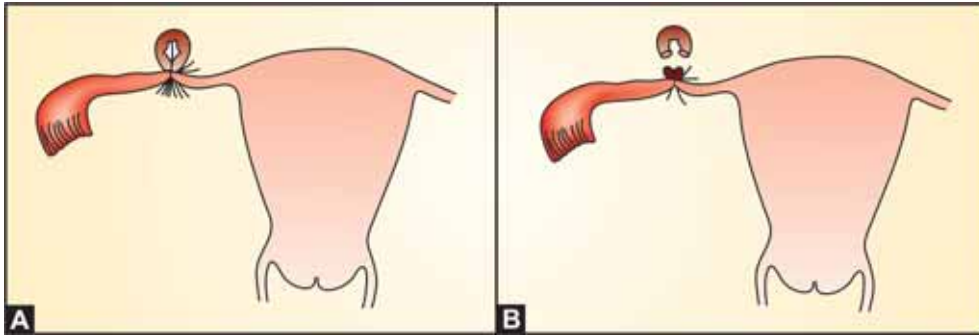
### Female Sterilisation

#### *Techniques*

Although irradiation, oophorectomy or hysterectomy would result in sterilisation, they are associated with a higher immediate morbidity as well as long-term side-effects. They are therefore not recommended as methods for sterilisation alone, being used only when concurrent disease in these organs warrants their removal.

Of the more simple operations on the fallopian tubes, the best is the *Pomeroy* procedure in which a loop of tube is excised and the cut ends secured with a ligature (Fig. 51.1). This method requires only limited access, is speedy, and fails in not more than 0.05 per cent of cases. The technique of crushing and ligation of the tubes without excising any part of them (*Madlener* operation) is very unreliable, the failure rate being 3.0 per cent; it is rarely practised now.

Whatever technique be used for dividing the tubes, it is important to ligate their cut ends with *plain catgut*. This is much more likely to result in the cut ends of the tubes falling apart than with the use of unabsorbable material, or even chromic gut. Most failures are due to neglect of this very important medicolegal point. It is important to select the site of tubal ligation carefully which should ideally be done at the tubal isthmus. This is because in the event of the patient desiring a tubal recanalisation procedure, the isthmo-isthmic anastomosis carries the best chances of success.



**Figs 51.1A and B:** Types of tubal resection (ligation) sterilisation procedures. (A) Madlener operation in which the tube is tied and not resected; this is most unreliable. (B) Pomeroy operation, for which an absorbable suture material should be used

Resection of the tubes is usually carried out abdominally and is particularly easy to perform 2-4 days after delivery when the uterus is an abdominal organ and the tubes, readily accessible. It can then, if necessary, be carried out under local analgesia. It can also be performed at the time of caesarean section. In the interval period or postabortally, it can be performed through a suprapubic mini-laparotomy incision. Tubal resection (preferably using the Pomeroy technique) can also be performed vaginally during the course of another operation, e.g. Fothergill's operation. However, the vaginal operation usually results in the tubes being divided lateral to the isthmus which may pose a problem if the patient later desires recanalisation.

The portions removed from the tubes, either abdominally or vaginally, should always be submitted for histological examination. This is to provide evidence that, in the event of the patient subsequently conceiving, the operation was properly performed. This precaution may be the first indication to a gynaecologist that a piece of round ligament was removed and not the tube on one side, in time to warn the patient before the operation 'fails'.

Several techniques of sterilisation like Irving's, Uchida's, Parkland's, Kronig's, Aldrich's and Shirodkar's methods have been described but these are not commonly practised.

#### *Laparoscopic Sterilisation*

Destruction of the isthmic portions of the tubes under laparoscopic control is in vogue because the method avoids making surgical incisions which are longer than 1-2 cm and normally cause the patient such little discomfort that she can return home the same day. Its

sterilising effect is nearly as certain as surgical resection of the tubes and it appeals to women who think they are avoiding an operation.

It can be performed under local anaesthesia. The uterus and tubes are manipulated into convenient positions by a uterine elevator through the cervix or by a probe from above. A portion of each tube, with its inner margin 1 cm from the cornu of the uterus, is coagulated with diathermy and divided, or clips or rings applied. Diathermy involves the destruction of a large segment of the tube and this can pose a problem if subsequent recanalisation is desired. There are also increased chances of ectopic pregnancy if the procedure fails. The preference nowadays is for the use of silastic Yoon's rings which are placed over a loop of tube. This can be done through a single port and obviates the need for diathermy but the rings may be difficult to apply if the tube is fat or rigid. The Hulka clip (stainless steel and polycarbonate) and the Filshie clip (titanium lined with silicone rubber) are commonly used in the UK.

This method enjoys wide popularity and has much to be said in its favour, but it involves real hazards which are not always appreciated, particularly by those with limited experience. Claims for damages against doctors by patients who have sustained accidental injury during this operation are numerous. The accidents include not only those which can arise during the induction of a pneumoperitoneum with carbon dioxide and the insertion of a laparoscope but also haemorrhage from the tube and from the vessels in the mesosalpinx which lie immediately beneath it. Injuries to major vessels like the aorta, vena cava and the pelvic vessels have been rarely reported. The rings may inadvertently be applied on the gut, round ligament or infundibulopelvic

ligament. If diathermy is used, burns of the bowel and other structures are not uncommon.

In general, a competent surgeon can resect the tubes more quickly and safely by way of a small incision placed transversely immediately above the symphysis pubis or transversely in the anterior vaginal fornix, than by laparoscopy. Neither approach results in significant postoperative incapacity for the patient or a visible scar.

### *Obstructing the Tubes Via the Uterus*

Methods of interest but not of practical importance include the following:

In the past, attempts were made to seal the inner ends of the tubes with diathermy, passing the electrodes blindly through the cervix up to the cornua of the uterus; they usually failed in their objective. Hysteroscopic cauterisation of the cornu was also abandoned because of a high failure rate of about 30 per cent and other complications, e.g. uterine perforation and intestinal burns.

Some workers have obstructed the lumina of the tubes along their length by injecting into them, via the uterus, liquid non-irritant materials or injecting chemical irritants to produce aseptic endosalpingitis. Chemicals like methyl cyanoacrylate and quinine have been used to destroy the cornual end. Quinacrine has been used in some large-scale trials. A 252 mg pellet is inserted postmenstrually through a modified IUCD inserter and the insertion is usually repeated in the next cycle. Inflammation and fibrosis of the interstitial portion of the tube occurs. The failure rate is 2.6 per hundred woman-years (HWY). Although the method is cheap and simple, it has been criticised on ethical grounds as it is irreversible, its safety unclear and it is not approved for use universally.

A device called the FEMCEPT has been used to deliver substances like 0.6 ml methyl 2-cyanoacrylate directly into the tubes. A cannula with the distal balloon which has a lateral opening is introduced transcervically and insufflated. This facilitates direct delivery of substances into the fallopian tubes without reflux. Only by hysterosalpingography carried out a few months later can there be any assurance that occlusion has been achieved. Tubal occlusion is reported in 72-88 per cent of patients with a single application which increases to 96 per cent if a second application is repeated one month later. The procedure does not require anaesthesia, can be done on an outpatient basis and takes only 5 minutes.

The draw-backs of quinacrine are also applicable to this method.

Resorcinol and formaldehyde have been used similarly. Plastic plugs have been inserted in the hope of developing a reversible method of contraception.

### Contraindications

It may be advisable to delay the sterilisation procedure if any of the following is present: unexplained vaginal bleeding, pregnancy, serious postpartum or post-abortion complications, e.g. infection or haemorrhage, pelvic inflammatory disease within the last three months, current sexually transmitted disease (STD), genital cancer, deep vein thrombosis, acute medical problems or anaemia with a haemoglobin level less than 7 g/dl.

### Reliability

The only sterilisation procedures in the female which are both satisfactory and reliable are resection or destruction of a portion of both fallopian tubes; and hysterectomy. No method, however, is absolutely reliable and pregnancy is reported after subtotal and total hysterectomy, and even after hysterectomy with bilateral salpingectomy. The explanation for these extremely rare cases is a persisting communication between the ovary or tube and the vaginal vault.

Even when tubal occlusion operations are competently performed and all technical precautions are taken, intrauterine pregnancy occurs subsequently in 0.05 per cent of cases. This is because an ovum gains access to spermatozoa through a recanalised inner segment of the tube.

There is a clinical impression that tubal resection operations are more likely to fail when they are carried out at the time of caesarean section than at any other time. The fact that they occasionally fail at any time has led many gynaecologists to replace the term 'sterilisation' by 'tubal ligation' or 'tubal resection' in talking to the patient and in all records. This has real merit from the medicolegal standpoint.

Many babies born after sterilisation operations have been conceived *before* the operation. Tubes can be tied when a 7-10-day-old ovum is already embedded in the endometrium. Because of this, a curettage should always be done at the time of every sterilisation procedure unless the patient is in the immediate postmenstrual phase. It is difficult to counter the presence of a 1-3-day-old

conceptus in the outer end of the tube. Unless advised to the contrary, women may practise unprotected coitus within the 48 hours prior to entering hospital to be sterilised, feeling it is quite safe to do so. If they do, and if conception occurs, the operation results in imprisonment of the fertilised ovum in the outer end of the tube. Collapse of the patient due to ectopic pregnancy is recorded during the few weeks following either tubal ligation or hysterectomy.

### Adverse Effects of Tubal Resection

#### *Immediate*

Surgical division of the tubes involves the usual risks of an invasion of the peritoneal cavity. When it comes to the woman who is so ill as to present a medical indication for sterilisation, the danger can be considerably higher and this is not always appreciated. Thus, it is not uncommon for a woman with severe heart disease, having been nursed through pregnancy and labour with difficulty, to be exposed to abdominal tubal ligation a few days after delivery — at a time when heart failure is common. In all such cases the operation should be deferred for at least 3 months.

Indeed, whenever *severe* systemic disease is the contraindication to further childbearing, there is much to be said for recommending contraception on the understanding that, if it fails, the pregnancy will be terminated. In this way many sterilisation operations on women at special risk can be avoided.

The immediate possible complications of laparoscopic sterilisation have already been described.

#### *Remote*

Late sequelae, apart from those attending any abdominal operation, are the rare occurrences of ectopic (stump) pregnancy and of torsion of the unsupported outer end of the tube. Otherwise operations on the fallopian tube generally have no permanent physical ill-effects.

These procedures should not disturb menstruation and *ought* not to influence sexual feelings and coitus. In some cases they increase libido because both partners are relieved of the dread of pregnancy. Nevertheless, it must be recognised that *sometimes* the very knowledge that pregnancy cannot result consciously or subconsciously detracts both man and woman from the pleasure of coitus. As mentioned previously, the partners

do not always like to be deprived of the right to have more children and, when the tubal ligation is carried out without adequate counselling, there can be psychological repercussions. The woman may be left with a sense of guilt or deprivation of her right.

A tension state may follow tubal ligation, caused partly by the operation and partly by the circumstances leading to it. Hence, menstrual irregularities, dysmenorrhoea, dyspareunia, menstrual tension and other functional disorders are not uncommon. In many cases such disorders are present prior to the operation but were not uncovered by the preoperative assessment. Others may have been using oral contraceptives (OCs) prior to sterilisation. Interruption of the blood circulation in the mesosalpinx may also lead to a state of congestion which results in menorrhagia.

As *new* developments, regret and other psychological reactions do not follow the operation in more than 2 per cent of cases and, if the selection of cases is good, 95 per cent of women and their husbands are well satisfied with the results.

### Male Sterilisation

Sterilisation of the male partner, even in the interests of the female, is being practised increasingly on the grounds that it involves a much simpler and less hazardous operation. It can have an important part to play in family planning and in population control. Despite the present enthusiasm for male rather than female sterilisation and its growing popularity, there is a need for caution in its application. The man must be convinced that he wishes it and not be persuaded by his wife. Moreover, it is to be avoided in young men. If a woman is sterilised on the grounds of parity the objection to her having more children remains in any subsequent marriage. If, however, a man is sterilised because of his wife's parity, his position becomes untenable if he later marries a nulliparous woman whose concern is to have a family.

### Techniques

#### *Vasectomy*

By this is meant the removal of a portion of each vas, not the complete structure as the term suggests. This is a minor surgical procedure, which for reasons of economy is often performed under local anaesthesia without hospitalisation of the subject. Several methods of dealing

with the vasa are described, sometimes with the object of making it easier to anastomose the cut ends if the need arises in the future. Reliable sterilisation, however, calls for removal of 3-4 cm of each vas, care over the suture and separation of the remaining cut ends.

Following vasectomy, active spermatozoa still appear in the ejaculate for 2-3 months and sometimes for much longer. So the man must be warned to practise contraception until two successive specimens of semen are shown to be *free* from spermatozoa. During this time frequent coitus with consequent many (about 20) ejaculations tends to clear the reservoir; so long as any spermatozoa are found, even isolated non-motile ones, pregnancy is still possible.

There are reports of the finding, in centrifuged semen, of a few non-motile spermatozoa in 40 per cent of cases at 6 months, and in 15 per cent of cases at 12-18 months, after operation. This can happen, it is said, in men pronounced sterile at 3 months, the spermatozoa having been lurking in the ampulla of the vas or the seminal vesicles.

### *Contraindications*

Vasectomy is not recommended in the presence of active STD, scrotal skin infection, scrotal mass, filariasis or infection in the genital tract. If there is a hernia, it should be repaired concurrently.

### *Reliability of Vasectomy*

Once the semen becomes clear of spermatozoa the man is usually permanently sterile but recanalisation and junction of the segments of the vas can occur. For this and other reasons, and despite observation of the above rules, 0.2-0.4 per cent of vasectomised men subsequently father a pregnancy.

### *Adverse Effects of Vasectomy*

Immediate complications are not common but, even in the hands of competent surgeons, scrotal haematoma, scrotal abscess and epididymitis can follow the operation.

Later, there are no physical ill-effects and coitus with ejaculation continues normally. There is some evidence that the retention and dissolution of spermatozoa can result in the development of spermagglutinins and other antibodies in the circulation. Such a happening may explain why, when the vasa are subsequently

reanastomosed, the man sometimes remains sterile although not azoospermic. Sperm granulomas may form at the cut ends of the vas. These are inflammatory swellings consequent to sperm leakage. They may need excision if they are painful. A higher failure rate has been associated with the presence of granulomas.

There may be psychological repercussions in the man or his wife, or both. Many women, whilst not wanting more children, dislike the idea that their menfolk are sterile. The husband may subconsciously feel that he has lost his manhood. Frigidity, impotence and failure to achieve orgasm are described in either or both partners. But, again, if the cases are well chosen such sequelae are rare and studies show that only 1-2 per cent of wives and husbands have any sort of adverse reaction.

### **No-scalpel Vasectomy**

The technique of no-scalpel vasectomy, first developed in China, is gaining immensely in popularity. As the name suggests, no scalpel is used. A stab incision is made with a specially designed instrument, the vas is isolated, delivered through the scrotum and ligated; the procedure is repeated on the other side. No suture is required and the patient can return home the same day. This procedure has been found to be highly acceptable.

### **Other Methods**

Percutaneous injection of sclerosants has been tried in China. Silicone plugs have been injected into the vas which can be removed if recanalisation is desired.

### **Compulsory Sterilisation**

The idea of compelling an individual to submit to sterilisation is contrary to medical ethics and to the English law. Nevertheless, it is a subject which has received some consideration and the procedure is permissible in some parts of the world. In a few States of the USA, for example, compulsory sterilisation of certain types of mentally diseased persons is legal. The procedure is covered by many safeguards and, in practice, is rarely carried out. Compulsory sterilisation was freely performed on racial, genetic and political grounds in the dictatorship countries of Europe before and during World War II. In developing countries, attempts at compulsory sterilisation with a view to population control have not been favourably received.

## TERMINATION OF PREGNANCY

### Ethical and Legal Considerations

After it is viable, the foetus *in utero* is protected by law in most countries and accorded the rights of an individual human being. Whether it has such rights before viability is a subject of dispute and opinion but the Courts have already upheld a claim for damages brought by a child who was alleged to suffer disability as a result of an accident sustained by his mother when only 8-10 weeks' pregnant.

In any case the embryo or foetus of any age is protected by the Hippocratic code.

The World Medical Association laid down some principles in the Declaration of Geneva and stated that 'abortion should only be performed as a therapeutic measure' and that doctors should be advised always to act on the principle 'I will maintain the utmost respect for human life from the time of conception'.

Through the ages, the laws governing the induction of abortion have changed from time to time and from country to country, but those enacted in the nineteenth century generally aimed to make termination of pregnancy an offence unless it was definitely needed to save the life or health of the mother. In recent years, however, there has been a remarkable shift in world opinion with consequent liberalisation of the abortion laws in many countries and states; in some they even provide for abortion on socioeconomic grounds alone or on the request of the woman concerned. Indeed, there is no doubt that more has been learned about termination of pregnancy as a medical procedure and as a social phenomenon during the past 30 years than at any other time.

The changes are motivated by a need to: eliminate the practice of criminal abortion; avoid the economic and other stresses which the birth of a baby imposes on an unmarried mother; remove unwanted pregnancies which result in unwanted and therefore neglected children — here there was, and is, confusion with 'unplanned' pregnancies, in the sense that there was no deliberate attempt to conceive and they represent 20-30 per cent of all pregnancies; abolish illegitimate offspring; and provide an additional means for family planning and population control.

It has long since been well established that the widespread practice of abortion does not solve these problems. With increasing emancipation, it is the right,

it is said, of any woman to decide whether her pregnancy be removed, even though she is ignorant of what this involves and of the attendant risks to her life and health. There remain, however, religious groups who regard termination of pregnancy as being morally unacceptable in any circumstances, even if the life of the mother is seriously threatened. There also remain countries in which the law either forbids abortion or allows it only for strict medical indications. So the world is divided into three parts, one in which only narrowly defined medical indications permit abortion, a second in which abortion remains therapeutic but with very liberal views on the interpretation of 'therapeutic' and a third where pregnancy can be terminated on socioeconomic grounds alone and this means on request or demand. Gynaecologists working under the first of these conditions meet few cases in which abortion is indicated or permissible and their actions need to be guided by the following rules:

- The need for terminating pregnancy must be determined for each case and must be strong enough to be accepted, if the position arises, by a Court of Law.
- The need must be agreed to by not less than two doctors of high professional standing.
- The operation should only be performed in a reputable hospital by a specialist gynaecologist who is convinced of its propriety.
- Those advising therapeutic abortion should satisfy themselves that the physical and mental hazards of the procedure are less than those of allowing the pregnancy to proceed.

Doctors working in areas where the abortion laws, although liberalised, still recognise only medical and medicosocial indications for terminating pregnancy have to observe the regulations which apply to their particular community. These sometimes rule out abortion after the twentieth week (400-500 g foetus); and in many places each case has to be judged by a special tribunal, set up by a hospital or the government, and not by individual doctors.

A liberal abortion policy has important consequences for society as a whole. The outcome includes:

- The outlook on abortion changes among the public, medical and nursing professions, criminal abortionists and Courts of Law.
- The practice of criminal abortion, although not eliminated, is considerably reduced.



- The number of maternal deaths from abortion of all kinds are reduced.
- There is a lowering of moral standards with an increase in sexual freedom in the expectation that any resulting conception can be removed.
- There is an increase in STDs.
- The last two consequences are seen particularly among young girls, less than 16 years of age, in whom pregnancy creates a special problem because it is often not diagnosed until it is so far advanced that it cannot be interrupted or can only be interrupted at great risk. This is because, in young girls, the occurrence of amenorrhoea is often dismissed (by them and their parents) as being of no significance.
- The practice of contraception is discouraged as being unnecessary and this is particularly true of the young who, having had one pregnancy terminated, become heedless if not promiscuous and soon come back with another. In some countries 50 per cent of those who have had one abortion return for another within 2 years.
- The illegitimacy rate is not reduced, although this may reflect a change in the views of the modern generation regarding marriage.

### Indications for Therapeutic Abortion

In assessing whether termination of pregnancy is truly in the interest of a woman's physical and mental health, it is proper to take a wide view and to recognise that medical indications change from time to time with advancing knowledge. As one disease no longer contraindicates pregnancy, another takes its place. Moreover, an assessment of the impact of pregnancy, or of having more children, on any disease must take into consideration the domestic background. For example, a physically handicapped woman who is in good circumstances with help available is in a different position from one similarly handicapped who is older, without a good home, or who cannot rest because of having other children in her care.

Even when a strong medical indication is present, the medical attendant can do no more than advise termination of pregnancy and explain the reasons. Some women, even those without religious scruples, refuse the operation despite their life being at stake. These are mostly those pregnant for the first time with no responsibility for other children. In adopting this attitude they may well be wise for, when maternal instinct is

strong, life without at least one baby may seem worthless. A short full life may be better than a longer empty one, but consideration for the quality of life of the unborn foetus is also of importance.

This raises the need to emphasise that valid consent of the woman is essential before a pregnancy is terminated and that of her partner, although not essential, is desirable.

The possible indications for therapeutic abortion are so many that they cannot all be listed. The following are the main ones.

### Pre-existing Maternal Disease

#### *Heart Disease*

It is extremely difficult to assess how the heart will tolerate pregnancy so it is rarely justifiable to terminate *a first* pregnancy, no matter how serious a woman's cardiac state may appear. Therapeutic abortion *may* be indicated when there is a history of heart failure or cardiomyopathy in a previous pregnancy; when heart failure occurs early in pregnancy — in such cases *abortion must not be induced until the crisis has passed* and until compensation is temporarily restored; in cases of Eisenmenger's syndrome, Marfan's syndrome, cyanotic heart disease, coarctation of the aorta, severe aortic stenosis or primary pulmonary hypertension; or when a woman with moderately severe cardiac disease already has two or more children and is physically incapable of attending to the welfare of any more. Pregnancy should be terminated in the first trimester. Termination in the second trimester has almost the same risks as labour at term.

#### *Severe Degrees of Chronic Hypertension*

These are indications, especially if associated with myocardial or renal damage.

#### *Kidney Disease*

Chronic renal disease of any kind with evidence of impaired function justifies therapeutic abortion. Previous removal of one kidney is not an indication if the other one is healthy.

#### *Pulmonary Disease*

Pulmonary insufficiency is as important an indication as is severe heart disease. It can result from bilateral lung

disease but is often the result of radical chest surgery for tuberculosis or bronchiectasis. A vital capacity of at least 1500 ml is necessary if a woman is to be reasonably certain of escaping death from cardiorespiratory failure in late pregnancy and labour.

### *Diseases of the Alimentary Tract*

Possibilities under this heading are impaired liver function, pancreatitis and ulcerative colitis (sometimes made worse, sometimes better by pregnancy).

### *Diseases of the Central Nervous System*

Organic diseases such as disseminated sclerosis and paralysis of various kinds are not made significantly worse by pregnancy.

It is doubtful whether an intracranial aneurysm is less likely to rupture as a result of induced abortion than of pregnancy and labour.

### *Psychiatric Disorders*

Mental disorders are not strictly acceptable medical indications for inducing abortion unless they are *being caused or made worse by pregnancy*.

Psychological indications cover a wide field, so wide that they are easily abused. They vary from frank psychoses induced by pregnancy to emotional distress at the idea of having a child which has been conceived under unfavourable circumstances, including rape and incest.

Some women have only to issue a meaningless threat of suicide to find someone to advise abortion. It is extremely rare for a woman to commit suicide after being refused termination of pregnancy on psychiatric grounds. Nevertheless, in certain areas and hospitals, psychological disturbances, which amount to no more than normal reactions to unwanted pregnancies, head the list of all indications for therapeutic abortion.

### *Malignant Disease*

There is a possibility that malignant disease, or any islets of cancer cells remaining after treatment, are activated by the hormone conditions of pregnancy. For this reason, many consider abortion justifiable in a woman who is suffering from, or has suffered from, cancer. The position is difficult to assess because cancer in a young woman (and she must be young to become pregnant) is generally

virulent and its unfavourable behaviour may well reflect age rather than pregnancy. Although many cancers appear to be unaffected by pregnancy the ultimate outcome may still be unfavourable and its treatment may affect the foetus. There is firm evidence of an adverse effect of pregnancy on cancers arising in the breast and the salivary glands.

### **Diseases of Pregnancy**

These include severe hyperemesis gravidarum, liver necrosis, bilateral pyelonephritis not controllable by other means, and pregnancy psychoses.

### **Fetal Disease and Malformation**

Foetal death or malformation and hydatidiform mole are indications for abortion.

Foetal malformation or genetically transmitted disease is a clear indication when its presence is established by special tests such as chromosome analysis carried out on cells obtained by amniocentesis, chorion villus biopsy or ultrasound. Often, however, termination of pregnancy is justified by a strong probability of abnormality as may be suggested by the following circumstances:

- **Viral disease:** If the mother contracts rubella within the first 3 months of pregnancy it can be lethal to the embryo. If it is not, there is a risk that the foetus will have a malformation of the brain, eyes, ears or heart. To disturb organogenesis, maternal rubella need not be present in a severe form and may not even be clinically manifest. However a woman who conceives within 2 months of being *vaccinated* against rubella need not have her pregnancy terminated.

No association between fetal malformation and other maternal viral infections such as mumps, measles, poliomyelitis and influenza has been demonstrated convincingly. Exposure to chicken pox in the first twelve weeks of pregnancy can lead to significant anomalies, especially the involvement of the central nervous system.

- The inadvertent exposure of the foetus to *heavy* irradiation or to noxious drugs in the first trimester is known to cause malformations.

### **Methods of Terminating Pregnancy**

Many techniques are available for inducing abortion therapeutically (and legally) and this alone indicates that

they all have disadvantages. The choice is governed to a large extent by the duration of the pregnancy to be terminated, the general health of the woman, and whether a sterilisation procedure is also necessary. Personal opinion and experience also influence the choice. Whichever the method applied, unless the patient is sterilised as well, it is important to administer anti-D gamma globulin to rhesus-negative women to protect them from isoimmunisation. For pregnancies of more than 12 weeks' duration, a dose of 300 µg is appropriate.

This means that the blood group as well as the haemoglobin level must be determined preoperatively. After the abortion, follow-up of the patient for after-effects and for instruction in and supervision of contraception is important, but can be difficult to arrange.

## First-trimester Termination

### Medical Methods

Medical methods of abortion can be tried up to 9 weeks' gestation. Mifepristone (RU 486), a synthetic steroid, binds to the progesterone receptor and blocks its action. Used alone in a single oral dose of 600 mg, it brings about complete abortion in 60 per cent of pregnancies; this success rate is increased to 95 per cent if a prostaglandin (sulprostone 0.25-0.5 mg i.m., or gemeprost 1 mg vaginal pessary, or most commonly, misoprostol 800 µg vaginally) is administered 36 to 48 hours later. Abortion occurs 4 hours later with pain and bleeding and is usually likened to a heavy period. If it does not, the dose of prostaglandin is repeated. Bleeding may occur for 10-20 days. Patients are re-evaluated after 2 weeks to assess whether suction evacuation is required.

There are no significant adverse effects with the mifepristone—misoprostol combination. Heavy bleeding causing collapse is seen in less than 1 per cent of patients, while severe pain is seen in 10-20 per cent. Some women are averse to the two-stage nature of the procedure.

Contraindications to medical abortion include: gestation of more than 9 weeks; extrauterine gestation; cardiac disease; asthma; bleeding disorder; anti-coagulant therapy and adrenal insufficiency. Medical abortion is relatively contraindicated in women who are over 35 years of age, those with hypertension, obesity and heavy smokers. Myocardial infarction has been reported in women with these problems who received sulprostone.

A combination of methotrexate—misoprostol has also been used. Methotrexate 50 mg/m<sup>2</sup> is administered i.m. on day 1 followed by 800 µg misoprostol vaginally on day 7, repeated, if required, on day 8. Complete abortion occurs in 92 per cent of cases. Compared with the mifepristone—misoprostol combination, it is slightly less effective, takes longer for abortion with a longer interval of vaginal bleeding but is cheaper.

Tamoxifen 20 mg bd for 4 days followed by misoprostol has also been tried and the results have been found to be comparable to methotrexate—misoprostol.

### Suction Curettage

This is the method of choice and is applicable to pregnancies up to 10 weeks' duration and is done usually under sedation with paracervical block or under general anaesthesia. After passing a sound and dilators, a flexible plastic or metal cannula, with dimensions appropriate to the size of the conceptus, is directed into the uterus and suction applied to it to create a negative pressure in the range of 650-700 mm Hg. The cannula most commonly used is that designed by Karman which is usually 6-8 mm in size. The endometrium is curetted and the fragmented conceptus is sucked into a special container. The operation is completed by conventional curettage which removes the remaining products of conception.

Suction evacuation done prior to 7 weeks' gestation is more likely to result in incomplete abortion or even in continuation of pregnancy if the foetus is missed. The procedure should therefore be deferred until this time for optimal results. Blood loss and related complications are proportional to the period of gestation so there should be no undue delay once the decision for termination is made. Previous administration of prostaglandin E<sub>2</sub> cervical gel 6-8 hours before the procedure reduces the risk of haemorrhage and of trauma to the genital tract.

Gestation of between 10-14 weeks' is a grey zone. Vacuum aspiration can be done but the risk of blood loss and trauma to the genital tract increases. Termination can also be done by intramuscular prostaglandins (*see below*).

## Mid-trimester Abortion

### Medical Methods

Intra-amniotic instillation of various solutions was a popular method for terminating pregnancies in the

second trimester, after the fourteenth week. The materials used were: 40 g sodium chloride in 200 ml of water; a 25 per cent solution of mannitol; 80 g of urea in 100 ml of 0.9 per cent saline; or a solution containing prostaglandins (*see below*).

The presence of renal disease or hypertension is a contraindication for the use of saline or urea and, before the last is given, blood urea estimation is always essential. When saline is used, 50 per cent is absorbed and can cause some blood electrolyte changes; another consequence is a minor degree of disseminated intravascular coagulation in four out of five cases. This can usually only be detected by haematological studies but, rarely, the full and dangerous clinical picture is seen. If saline enters the bloodstream by accident, death of the woman occurs; the significant findings at autopsy are multiple foci of oedema and haemorrhagic necrosis in the brain.

It may take the uterus 2-4 days to expel its contents and the mean induction-to-abortion interval is 20-46 hours, varying with the agent employed.

Because of the serious nature of the side-effects, this method of termination of pregnancy has been superseded by the use of prostaglandins.

### Prostaglandins

These are acidic lipids which have a capacity to stimulate smooth muscle. In minute amounts they have a wide distribution in the body but, for therapeutic purposes, they are manufactured biosynthetically.

In obstetrics, and for inducing an abortion, the ones in current use are mainly prostaglandin  $E_2$  ( $PGE_2$ ) and prostaglandin  $F_{2\alpha}$  ( $PGF_{2\alpha}$ ). In general,  $PGE_2$  is used to produce cervical dilatation (although dinoprostone has been used successfully for mid-trimester abortion), and  $PGF_{2\alpha}$  to stimulate the uterine myometrium to contract.

Gemeprost is a  $PGE_1$  analogue used for mid-trimester abortion, but is not yet widely available. Prostaglandins such as these cannot be administered orally in doses sufficient to terminate pregnancy without causing severe vomiting, diarrhoea and other systemic upset. So they are applied in other ways, mainly to interrupt mid-trimester pregnancies. By themselves, they are inefficient at an earlier stage. Prostaglandins are also used to promote the expulsion of a missed abortion.

Misoprostol is a  $PGE_1$  analogue which is administered orally and is effective in inducing an abortion in both the first and second trimester.

**Intramuscular injection:** Intramuscular injections of 15-methyl prostaglandin  $F_{2\alpha}$  (carboprost, trometh-amime) 250  $\mu$ g are administered every 2-3 hours up to a maximum of 10 doses. The mean induction-to-abortion interval is 16 hours and 87 per cent of patients abort successfully within 24 hours. Pre-treatment with laminaria tents or  $PGE_2$  gel has been shown to increase the success rate to 95 per cent while decreasing the mean induction-to-abortion interval to 8 hours. It also decreases the incidence of bucket-handle tears in the cervix.

In 40 per cent of cases, abortion with intramuscular prostaglandin is incomplete and needs to be completed with curettage. There is a high incidence of nausea, vomiting, diarrhoea and cramping abdominal pain. So prophylactic antiemetics and intestinal motility inhibitors are often recommended. Bronchospasm and mild fever may occur. Prostaglandins should not be used in asthmatics or in patients with a compromised cardiovascular status. Sulprostone, a  $PGE_2$  analogue used intramuscularly, was as effective as intramuscular  $PGF_{2\alpha}$  in inducing abortion but was withdrawn following reports of cardiovascular deaths.

**Intra-amniotic injection:** Prostaglandins injected into the amniotic sac by way of abdominal amniocentesis are safer than 20 per cent saline and other solutions. After withdrawing 10 ml of liquor under aseptic precautions, 2.5 mg (10 ml) 15-methyl  $PGF_{2\alpha}$  is instilled intra-amniotically. This procedure need not necessarily be done under ultrasound guidance, but units equipped with the facility prefer to use it to avoid penetrating the placenta. The mean induction-to-abortion interval is 12-14 hours. In general, there are few adverse effects, certainly fewer than those seen with the parenteral administration of the drug; however vasovagal collapse, or more usually transient hypotension, can be an immediate reaction; occasional cases of cardiovascular collapse and death have been reported. Pyrexia, vomiting and diarrhoea may occur.

**Intravaginal applications:** Vaginal pessaries containing 1 mg gemeprost are applied 6-hourly (up to 4 doses) between 12 and 16 weeks of gestation. In 82 per cent of patients abortion is reported within 24 hours with a mean induction-to-abortion interval of about 15 hours. However, the placenta is expelled in only 7-40 per cent of cases, the rest require surgical intervention. Nausea, vomiting and diarrhoea are seen in 20-40 per cent of

patients. Rarely, cardiac arrhythmias have been reported even with the vaginal route.

Dinoprostone, a PGE<sub>2</sub> derivative, has been used as a 2.0 mg vaginal suppository every 3 hours. The mean induction-to-abortion interval in mid-trimester patients is 12 hours and 90 per cent abort within 24 hours. However, it is expensive, needs refrigeration and is not suitable for use in developing countries. It is contraindicated in patients with glaucoma and bronchial asthma.

Misoprostol has been used both vaginally and orally. A 400 µg oral dose 3-hourly up to 5 doses is successful for inducing mid-trimester abortion with a mean induction-to-abortion interval of 12 hours. A 200 µg dose used vaginally can produce the same effect. At 24 hours, 89 per cent of patients, and at 38 hours all patients receiving misoprostol are reported to abort. Adverse effects of nausea, vomiting and diarrhoea are seen with the same frequency as with gemeprost when the drug is administered by the oral route, but are seen in only 4 per cent of women in whom the drug is used intravaginally.

Misoprostol works well in pregnancies complicated by intrauterine foetal demise. It is effective from the mid-trimester up to 41 weeks. Three-hourly oral doses of 400 µg have been used in these patients. The induction-to-abortion interval in those with mid-trimester pregnancies has been found to be shorter in those with intrauterine foetal death (10.4 hours) than in those with a live foetus (15.4 hours).

Misoprostol is cheap, stable at room temperature and has a low incidence of side-effects, but is not yet widely available.

### *Ethacridine Lactate*

Ethacridine lactate (Emcredil) is an acridine derivative with uterotonic and antiseptic properties. The exact mechanism of action is unknown. A 16 F Foley catheter is used to introduce 0.1 per cent ethacridine into the extra-amniotic space in a dose of 10 ml per week of gestation to a maximum of 150 ml. The bulb of the catheter is inflated with 10-15 ml of saline to seal the internal os. The catheter is removed after 6 hours and an oxytocin infusion of 50 mIU/minute started to expedite the procedure. Alternatively, the catheter is left in place until it is expelled on its own once cervical dilatation occurs. The mean induction-to-abortion interval varies from 24

to 36 hours with ethacridine alone; with oxytocin supplementation it is about 18 hours.

Extra-amniotic 15-methyl PGF<sub>2α</sub> has also been used instead of oxytocin.

Ethacridine has been widely used in India because of the advantages of low cost, simple technique, low incidence of adverse effects and widespread availability. However, other inexpensive, more effective agents such as misoprostol may replace it in the future.

### Surgical Methods

*Dilatation and evacuation (D and E)* In the USA, medical termination of pregnancy (MTP) up to 16-18 weeks' gestation is done by D and E. The cervix is prepared by osmotic dilators, e.g. *Laminaria japonica*, Lamicel and Dilapan, or by pharmacological agents, e.g. vaginal prostaglandins. The uterus is evacuated under paracervical block with light sedation, short-acting intravenous barbiturates or general anaesthesia. Adequate training of the surgeon is an important prerequisite. The foetus can be removed by the intact or non-intact procedure. Sometimes foetocidal techniques are used 16-24 hours before the procedure to soften the foetal cortical bone and decrease the amount of cervical dilation required. The agents used to induce foetal demise are usually potassium chloride or digoxin, instilled transabdominally into the foetus or even into the amniotic fluid without ultrasonographic guidance.

Several special forceps have been devised for the D and E procedure and a combination of these may need to be used. With gestations of 14 to 16 weeks, suction evacuation with a wide-bore cannula may be sufficient. An oxytocin drip is kept running in both the methods. Paracervical instillation of vasopressin has been used to decrease the blood loss.

D and E is faster as compared with medical methods. It may be associated with greater blood loss and carries a higher risk of traumatic injury to the uterus and cervix from the bony spicules of the foetus and from perforation. However, in the USA it has been shown to be safer than medical abortion with intra-or extra-amniotic prostaglandins.

### *Hysterotomy*

Abdominal hysterotomy was performed for the removal of a second trimester pregnancy and for terminating

pregnancy at any stage if there was a need to sterilise the woman as well, but is now infrequently used. In seriously ill women, it can be performed under local infiltration anaesthesia without difficulty. The incision in the uterus should be a vertical one, placed as low as possible after reflection of the bladder and covered, in part at least, by the bladder subsequently. Some prefer 'lower segment' hysterotomy with a transverse incision but this is technically difficult; the lower segment is not of sufficient width at this stage in pregnancy.

This method has the advantage that it permits safe and complete removal of the products of conception without any injury other than that of the incision. Its disadvantage is that, being an abdominal procedure, it carries a slightly higher mortality rate (mostly from embolism) and leaves a scar in the uterus which is liable to rupture during a later pregnancy and labour. The danger of this is just as great as that following caesarean section at term and subsequent pregnancies should generally be delivered abdominally. If the woman is sterilised simultaneously, this problem does not arise. There is a greater incidence of scar endometriosis following hysterotomy than caesarean section.

### *Hysterectomy*

This maybe occasionally indicated if there is uterine disease as well as a pregnancy to be removed, e.g. leiomyomas. It carries a much higher morbidity rate than does hysterotomy or tubal resection. When the pregnant uterus is removed it should be by the abdominal route.

### **Dangers and Complications**

Termination of pregnancy, therapeutic or legal, is always potentially dangerous. When the indication is serious physical maternal disease, the risk is considerable. For example, when heart disease, pulmonary insufficiency and renal incompetence are reasons for inducing abortion, a fatal outcome in not less than one per cent, and *serious* postoperative complications in not less than 10 per cent of cases may be expected.

The morbidity rate also varies with the stage of pregnancy at the time of its interruption, the earlier it is done the safer it is. This is partly because the duration of pregnancy often determines the choice of method; abdominal hysterotomy is, in general, more dangerous than surgical evacuation of the uterus vaginally.

The whole subject of inducing abortion arouses such emotional reactions and political issues that it is impossible to obtain accurate statistics on morbidity, or even mortality rates either from official sources or from individual operators. The authorities in countries which keep reasonably complete returns also tend to understate the risks by introducing correcting factors and adjusting the figures by excluding a proportion of the deaths. On the other hand, those persons opposed to a liberal abortion policy, tend to exaggerate the incidence and seriousness of non-fatal sequelae.

Analysis of the evidence suggests that for women who are generally fit physically and whose pregnancies are terminated mostly by vaginal evacuation of the uterus, intrauterine injections or intravenous infusions of oxytocic agents, the dangers and complications are as follows:

### **Mortality**

High levels of mortality prevail when legislation is restrictive because only high-risk cases have pregnancies terminated. Where abortion is more liberal, mortality will be lower. For example, in the USA in 1973-75, mortality was about 3 per 100 000 legal terminations, but by 1976-78 it had fallen to less than 1 per 100 000. The period of gestation at which pregnancy is terminated is always a factor and in the USA during 1972-78, mortality ranged from 0.4 deaths per 100 000 legal abortions at 8 weeks or less to 16 deaths per 100 000 at 21 weeks or more (about a 30 per cent increase per week of gestation).

Presently, the WHO estimates that as many as 53 million pregnancies are terminated by induced abortion each year. One-third of these abortions are performed in unsafe conditions, resulting in about 50-100 000 maternal deaths each year, and many more women with long-term health related complications. It has been estimated that around 25 per cent of maternal deaths in Asia and 30-50 per cent of maternal deaths in Africa and Latin America occur as a result of induced abortion.

### **Morbidity**

#### *Immediate*

Significant operative and postoperative complications occur in 10 per cent of cases when the pregnancy is less than 12 weeks advanced. The figure rises to 15 per cent for 12-13-week pregnancies and 30-40 per cent for later

ones. The overall morbidity rate for all gestations is 12 per cent.

The complications included in these figures are:

- **Haemorrhage and shock:** These are always likely and can be severe. A loss of more than 500 ml of blood from the uterus occurs in 3-5 per cent of cases and a need for blood transfusion is reported in 2-5 per cent. This applies even when prostaglandins are used. The risk of haemorrhage is decreased if the procedure is carried out under local anaesthesia and if the cervix is prepared with prostaglandins.
- **Retained products of conception:** This complicates 10 per cent of procedures other than abdominal hysterotomy and necessitates conventional curettage.
- **Cervical injury:** Tearing of the cervix during surgical dilatation is common, especially in young primigravidae whose tissues are resistant. Gross injury is recognisable at the time in 1-2 per cent of cases and can cause haemorrhage and shock. Deep tearing of the undilated cervix can also result from violent uterine contractions induced by oxytocics, especially combinations of prostaglandins and oxytocin. Lateral tearing of the cervix, or expulsion of the conceptus through its posterior wall to leave a cervicovaginal fistula has been reported. In most of these cases, an oxytocin infusion was supplemented by an intra-amniotic injection of prostaglandin. This accident is least likely when the cervix has been primed, or the drug administered extra-amniotically, possibly because the balloon of the Foley catheter protects and opens the cervix.
- **Perforation of the uterus:** This occurs during not less than 0.3 per cent of evacuations by the vaginal route and in some cases the figure is as high as 2 per cent. This accident occurs even when the operators are skilled and when suction techniques are used; a sound, dilator, curette or suction tube can be the responsible instrument and the risk is particularly high when the uterus is retroverted. If the accident is not immediately recognised, intestines and other abdominal and pelvic viscera can be damaged. Management depends on the stage of the procedure at the time of occurrence (whether completed or not); the instrument causing the damage and the consequent size of the perforation; and damage to the abdominal viscera, chiefly the intestines, although vascular injury can also occur.

- **Infection:** Significant pyrexia follows termination of pregnancy in 5-10 per cent of cases and, in 1-2 per cent, this is caused by such severe endometritis, salpingitis and peritonitis as to leave the pelvic organs permanently damaged. Prophylactic doxycycline therapy reduces the risk.
- **Thrombosis and embolism:** Deep venous thrombosis and pulmonary embolism are more likely after abdominal operations than after vaginal procedures. Chemical and air embolism can complicate certain techniques.
- **Other complications:** These are only seen when certain techniques are used; they are referred to under the section on 'Methods'.

#### *Remote Psychological*

Maternal instinct may be so strong that permanent regret and remorse are left in the minds of some women who demand or agree to termination of a pregnancy. When the indications are flimsy from the standpoint of health the incidence of psychological reactions of some degree appears to be similar to that for pregnant women, being higher in divorced, separated or widowed women. Aborted and pregnant women are most at risk of admission to a psychiatric unit during the first 3 months after an abortion or delivery.

For the vast majority of women, feelings of guilt and depression are mild and transitory, followed by a sense of relief associated with resolution of a crisis.

#### *Remote Physical*

The late overall permanent physical disability rate is probably not less than 5 per cent comprising disorders listed below. The exact incidence of each or all is unknown because late follow-up studies are impracticable. Most women, and especially unmarried ones, do not wish to be reminded of the event some years later, by which time their circumstances are likely to have changed. They may, for example, have acquired a husband who knows nothing about the previous abortion.

- **Menstrual disturbances** include menorrhagia, polymenorrhoea, dysmenorrhoea, menstrual tension and occasionally amenorrhoea (Asher-man's syndrome). Some of these are the outcome of chronic pelvic infection and can give rise to a need for hysterectomy.

- **Infertility** is the result in 1-2 per cent of cases, being mostly caused by tubal obstruction secondary to salpingitis.
- **Abortion and premature labour** in subsequent pregnancies are 10 times *more* likely than expected in women who have had a pregnancy terminated, especially if they were primigravid at the time. The cause is cervical incompetence.
- **Rupture of the uterus** during a later pregnancy or labour. This may represent the dehiscence of a hysterotomy or cervical scar, with or without extension. Often, however, it occurs in an unsuspected weak area of the uterine wall, this being the result of an undiagnosed instrumental injury at the time of the evacuation.
- **Rhesus isoimmunisation:** Unless rhesus-negative women are routinely protected with anti-D gamma globulin at the time their pregnancy is terminated, 5-10 per cent develop antibodies which threaten their future reproductive life.
- **Ectopic pregnancy:** When tubes are damaged by infection but not closed there is a risk of tubal pregnancy in the future.
- **Cervical conditions:** These include ectropion, chronic cervicitis and cervicovaginal fistulas.
- **Endometriosis** of the cervix and vagina can develop after vaginal procedures; pelvic and scar endometriosis may follow abdominal hysterotomy.

### Abortion as a Means of Contraception

There are wide differences between preventing and terminating a pregnancy, judged not only ethically but by the procedures involved and their relative risks to life and health.

Because it is easier and safer to terminate a very early pregnancy there is a body of opinion in favour of

inducing abortion immediately the diagnosis becomes evident, or even suspected, without delaying to assess the case and to consider an alternative method of patient care.

### 'Lunchtime' Abortions

This term is sometimes used to denote the practice of terminating very early pregnancies as an out-patient procedure without anaesthesia, or with paracervical nerve block, and allowing the woman to return home within a few hours. Suction through the smallest polythene cannula is the method employed and satisfactory results are claimed. Except in highly developed organisations, the urgency of the operation may preclude a proper assessment of the case with cross-reference for the opinion of other specialists, including social workers. The practice is usually only acceptable where there is 'abortion on demand'.

### Menstrual Regulation

This procedure goes a stage further back in that it is intended for any woman whose period is a few days late, irrespective of whether she is pregnant or not. A small-bore plastic cannula is inserted into the uterus and suction applied with a 50 ml syringe. This extracts 'menstruation' or the endometrium and any blastocyst which may happen to be present.

The method is an unreliable means of disturbing a pregnancy and it introduces serious risk of infection, especially if repeated. It is in any case quite improper to expose a woman to an operation without a diagnosis being made as it may often be unnecessary.

In general, the risks of medical termination of pregnancy are higher than those of contraceptive methods, so the use of abortion as a method of contraception needs to be decried.



# CHAPTER 52

## Urinary Problems

Bladder Dysfunction	839	Incontinence of Urine	847
Urethral Sphincter Dysfunction	843	Enuresis	854
Investigation of Urinary Problems	844	Urinary Retention and Difficulty in Micturition	855
Treatment of Urinary Problems	846		

This chapter deals with those disturbances of bladder and urethral function which commonly present to the gynaecologist. To understand them a knowledge of the physiology of micturition and its control is necessary (*see* Chapter 2). This knowledge has been considerably enhanced in recent years by the development of urodynamics. Urodynamic studies enable the delineation between bladder dysfunction and urethral dysfunction, which aids the management of patients with urinary symptoms and, in particular, of women who present with urinary incontinence. This chapter initially describes the symptoms and signs of bladder and urethral dysfunction and then the investigation and management of these problems are discussed. Following that, urinary incontinence is described in greater detail and, finally, difficulties with micturition, including urinary retention, are discussed.

### BLADDER DYSFUNCTION

#### Bladder Irritability and Instability

Irritability of the bladder can be caused by local disease which directly stimulates the detrusor muscle or heightens the sensitivity of the stretch receptors in the bladder wall. The bladder muscle then becomes so insensitive that the central nervous system may fail to control it, producing detrusor instability.

Alternatively, irritability and/or instability may be the result of a primary error in the nervous inhibition of an essentially normal bladder muscle.

Irrespective of the mechanism behind detrusor irritability, the sphincter mechanism is normal, and the fault lies in the bladder which becomes intolerant of even moderate amounts of fluid. The clinical effects are frequency, urgency and nocturia. If detrusor instability develops then either urge incontinence or enuresis may occur. Moreover, if the bladder wall goes into spasm, pain and dysuria are added.

Dysuria can also be explained by any disease making the urethra or vulva sensitive to the passage of the urinary stream. Certain local causes of bladder irritability — those characterised by congestion and ulceration — also result in haematuria.

## Causes of Bladder Dysfunction

### *Polyuria*

A complaint of frequency, diurnal and/or nocturnal, is sometimes explained merely by an increased excretion of urine. This can be caused by the following:

- A cold environment, causing a reduction in the excretion of fluid by the body surface.
- A habit of drinking large quantities of tea, coffee or other fluids. Such a habit can have a background of nervous tension, loneliness, and unhappiness.
- The woman drinks to console herself or for want of something to do. This type of patient tends to have urgency as well as polyuria.
- *Pregnancy*: Except in the later weeks, when the presenting part crowds the pelvic organs and makes the bladder intolerant to large volumes, frequency in pregnancy may be explained by polyuria.
- Diabetes mellitus and diabetes insipidus
- Impaired renal function resulting in the output of large quantities of unconcentrated urine. This is mostly seen in old age.
- *Insomnia*: Women often attribute insomnia to a nocturnal desire to void. An alternative explanation is more likely. Because they are wakeful, their kidneys continue to secrete. This, as well as the need for something to do, causes the frequency and urgency.

## Mechanical Factors

### *Displacement of the Bladder*

Any displacement which stimulates the stretch receptors can cause a frequent desire to void. This is seen typically in cystocele, when the frequency is only diurnal because the displacement disappears on rest.

### *Pelvic and Lower Abdominal Tumours*

These may cause direct pressure on the bladder wall and result in diurnal frequency if they are mobile, or diurnal and nocturnal frequency if they are impacted in the pelvis.

### *Adhesions and Bands in the Uterovesical Pouch*

These may result from operations, infections and endometriosis. They act mainly by opposing enlargement of the bladder but, unless the causal disease is active and progressive, the bladder can learn to accommodate itself to the new anatomy.

### *Incomplete Emptying of the Bladder*

This is a common feature of cystocele and the patient, having voided, has an almost immediate urge to void again. Incomplete emptying is a common sequel to postoperative retention and is deceptive in that the patient complains of frequency and not of difficulty in voiding.

### *Diseases of Organs Adjacent to the Trigone*

Diseases of the anterior vaginal wall and the cervix, by causing congestion and irritation of the trigone, or by interfering with the nerve supply to the bladder, can be the basis for frequency and dysuria. They include the following:

- Any pelvic operation which disturbs the bladder base. Wertheim's and other radical operations often result in permanent detrusor dysfunction because they damage the innervation of the bladder as well as disturb the anatomy. Occasionally detrusor dysfunction follows pelvic surgery for benign disease but is usually less severe and may be temporary.
- Endometriosis of the anterior lip of the cervix, of the anterior vaginal wall or of the bladder wall itself.
- Carcinoma of the cervix. By the time this disease irritates the base of the bladder, the forward extension is usually serious and there is a threat of fistula formation.

Chronic cervicitis is *not* a cause of bladder irritability but may be associated with urethritis which may produce bladder irritability (*see below*).

### *Diseases of the Renal Pelvis and Ureter*

These include especially pyelonephritis and ureteric calculus.

### *Diseases of the Bladder*

All these are likely to cause dysuria, and sometimes haematuria, as well as frequency and urgency.

### *Cystitis*

The susceptibility of women to cystitis is commonly blamed on the shortness of the female urethra and the close proximity of the bacteria-infested vagina and anus. Approximately 8 per cent of women of childbearing age and 20-25 per cent of women over 60 years of age have significant bacilluria (100 000 or more organisms per ml

in at least two separate specimens). It requires little to change from a carrier to an infectious state. Precipitating factors include pregnancy, labour, operations, urinary retention and incomplete emptying of the bladder. In many cases, however, cystitis is traceable to catheterisation. Few women escape this procedure, requiring it at some time in life, in association with childbirth or operations.

The bacilluria of the apparently normal adult woman probably dates back to childhood when there may not have been overt attacks of cystitis. Recurrent cystitis in young girls can be associated with ureteric reflux which causes urinary stasis.

Recurrent attacks of acute cystitis in women are sometimes explained by an underlying nidus of low-grade infection in a hydronephrosis, diverticulum or other anatomical fault, but in many cases there is no evidence of these. When investigated, a number of women who suffer from recurrent cystitis are found to have lower urinary tract dysfunction -incomplete bladder emptying, for example. The attacks of frequency and dysuria may occur without evidence of any infection in the bladder. Often they represent exacerbations of chronic urethritis (*see below*). Otherwise a condition of allergic cystitis, and urethritis, is not uncommon. Attacks can be attributable to reactions to toilet preparations, antiseptics, drugs and chemical contraceptives.

#### *Diverticula*

These cause problems mainly because the urine residing within them becomes infected, or because of calculus formation. Bladder diverticula, except possibly multiple tiny ones, are uncommon in women.

#### *Vesical Calculus and Foreign Bodies*

Except when it forms in a diverticulum or an incarcerated cystocele, or around a foreign body, a vesical calculus is rare in women. This is because any stone which negotiates the ureter is easily passed through the short straight urethra (Fig. 52.1). Occasionally mineral deposits are found in the bladder in severe chronic cystitis.

#### *Papilloma and Carcinoma of the Bladder*

These generally cause haematuria as well as bladder irritability.

#### *Trigonitis*

In many women with long-standing bladder irritability, the only positive finding on investigation is slight injection of the vessels on the trigone. This leads to a diagnosis of 'trigonitis', despite the fact that urinalysis does not usually reveal any evidence of infection.

#### **Diseases of The Urethra**

Urethral conditions can reflexly cause bladder irritability or can account for dysuria which is mistakenly attributed to cystitis. They include the following.

#### *Trauma*

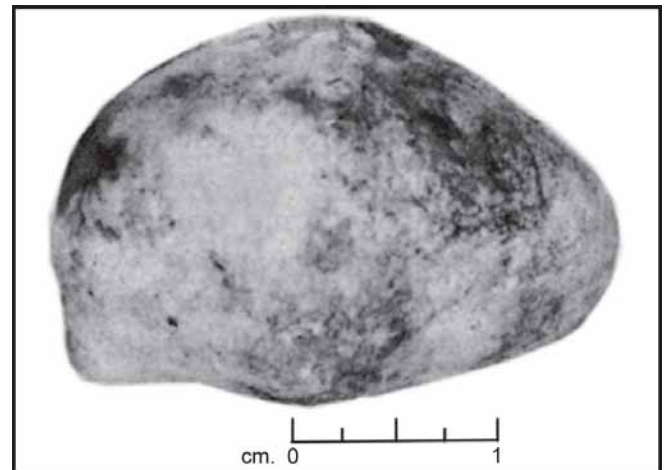
Urethral injury may be sustained during catheterisation, operation and childbirth. Coitus, too, can irritate the urethra and commonly causes a desire to void. 'Honeymoon cystitis' is mostly attributable to trauma of the external urethral meatus.

#### *Urethral Prolapse*

*See Chapter 27.*

#### *Urethritis*

Bacterial and viral organisms have been implicated in the aetiology of acute and chronic urethritis. In addition to bacterial pathogens isolated from the urine, *Chlamydia*, *Candida* and *Trichomonas* may result in infection of the urethra, producing symptoms similar to cystitis. Urine



**Fig. 52.1:** A urinary calculus passed spontaneously per urethram. Its size illustrates the distensibility of the female urethra

examination is generally unhelpful. The term *urethral syndrome* is used to describe the symptoms of frequency, dysuria and urgency produced by chronic urethritis. Atrophic urethritis commonly presents 2 or 3 years after the menopause and is an inflammatory mucosal reaction to oestrogen deficiency which often parallels changes in vaginal epithelium.

#### *Urethral Tumours*

These include caruncle, papilloma, diverticulum, para-urethral cysts and carcinoma (*see Chapter 27*).

### Diseases of The Vulva And Vagina

Any painful and tender lesion of the introitus or vulva can give rise to a complaint of dysuria as urine passes over it.

### Diseases of The Central Nervous System

Frequency of micturition and urgency are common manifestations of organic disease in the central nervous system. Examples include multiple sclerosis, previous vascular accidents and disc lesions of the spine which may be asymptomatic. *Among sufferers from multiple sclerosis, 60 per cent have urgency, 50 per cent frequency and 35 per cent urge incontinence at some stage of the disease. Moreover such symptoms are the first manifestations of multiple sclerosis in 2 per cent, and among the first in 12 per cent of cases.*

Neurological disease may produce a hyperactive or a hypoactive detrusor. The former is associated with urgency and urge incontinence and the latter with an atonic bladder, producing urinary retention and overflow incontinence. If the neurological deficiency affects both sensory and motor pathways an 'automatic bladder' results. This fills and empties without the woman being aware of it, the control being the basic spinal reflex.

Senility can result in loss of central inhibition and this, as well as incomplete emptying of an atonic bladder, causes frequency and urge incontinence.

### Functional — The Psychogenic Bladder

In some women suffering from chronic and resistant frequency and urgency, investigation fails to reveal an organic cause. At most, cystoscopic examination reveals

what is labelled 'trigonitis'. These may represent, in part, unknown pathology but often the cause of the bladder irritability is essentially a bad habit, or failure of the central nervous system to inhibit the detrusor reflex.

The habit of voiding frequently may develop in childhood, being acquired from another member of the family. Sometimes there is a history of enuresis in adolescence. Occasionally the dysfunction starts with true cystitis, or urethral injury during catheterisation, and persists when the primary lesion is cured. More often, the onset dates from psychological trauma such as death of the husband or a friend, a child sustaining a serious accident or illness, or a marital quarrel.

Sufferers from this functional disorder are generally women, sometimes girls, of anxious and tense disposition, nail biters, often lonely or unhappy with an insecure home life, fearful of cancer and full of complaints. They usually have had many operations, investigations and treatments, all with only temporary improvement in symptoms. Common associated conditions are irritable bowel syndrome, headaches, depression, nervous exhaustion and obesity (from seeking consolation in food). A past history of frank psychosis in the patient or in a close relative is not uncommon. Indeed, psychotherapy and hypnosis may be modes of treatment.

With this background the patient not only loses her inhibitory control of the bladder; the stretch receptors become more sensitive and the detrusor muscle itself is 'on edge' ready to contract at the slightest provocation. The provocation may be the thought of a full bladder, the sound of running water, or even physical movement. The escape of urine on changing position can give rise to a false diagnosis of stress incontinence.

When urge incontinence occurs, the woman loses confidence in her bladder and then voids more and more frequently in the hope of avoiding an accident. The bladder, therefore, is never allowed to fill and becomes intolerant of fluid. In severe cases, even 50 ml of fluid may be enough to excite detrusor contraction but the bladder *never* becomes organically contracted. Under general anaesthesia its capacity is always normal. Colicky action of the hypertonic detrusor can also cause intense pain and dysuria.

It is characteristic for the frequency and urgency to occur only by day. When severe, however, bladder spasms can wake the patient or lead to nocturnal enuresis.

## The Hypotonic Bladder

This is generally associated with neurological disease (as described above) but may follow pelvic surgery. If the motor denervation is accompanied by a sensory denervation, the woman will be unaware of the urinary retention until overflow incontinence develops. It is a far less common clinical problem than the hypertonic irritable bladder.

## URETHRAL SPHINCTER DYSFUNCTION

The urethral sphincter is designed to permit bladder emptying when required and to prevent escape of urine from the bladder at rest and when the intra-vesical pressure is increased secondary to raised intra-abdominal pressure. *Urinary loss which occurs with sudden elevations of the intra-abdominal pressure without detrusor contraction is called stress incontinence.*

Stress incontinence is reported as an occasional event in up to 50 per cent of young nulliparous women but sometimes may be more frequent. It occurs more commonly during pregnancy but frequently it first presents immediately after delivery. Thus pregnancy and delivery are implicated in the aetiology of the condition. In some women it first presents many years after pregnancy, inferring an age-related aetiology. Several factors contribute towards urinary incontinence with stress.

### The Urethral Sphincter

The internal smooth muscle and external striated muscle sphincter combine to provide a considerable functional reserve of urethral closure pressure (*see below*). Women with stress incontinence have a reduced maximum urethral closure pressure which reduces the capacity to resist urinary leakage under pressure. In urethral sphincter weakness, both the smooth and striated muscle components of the sphincter are invariably weakened.

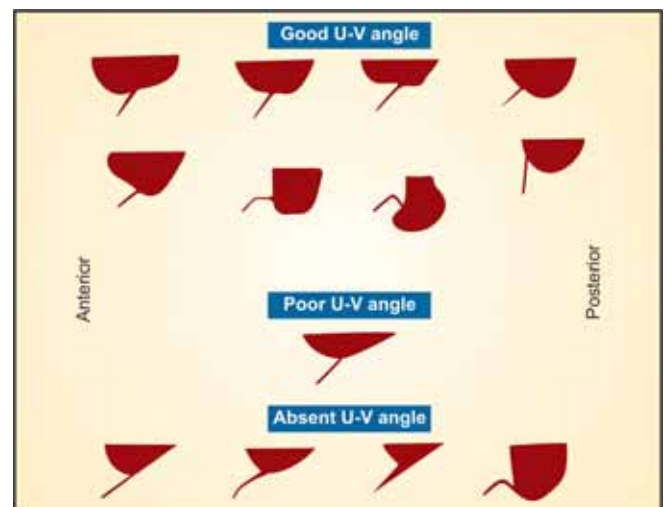
### Urethral Length

Weakness of the urethral muscle wall tends to result in funnelling of the proximal urethra, resulting in a shortening of the functional urethral length. It is unlikely that urethral shortening itself is a primary factor in the aetiology of stress incontinence.

### The Pelvic Floor

The pubococcygeus muscle of the pelvic floor lies lateral to the urethra on each side. Contraction of the pelvic floor elevates and lengthens the urethra and maintains the posterior urethrovesical angle due to the fascial attachment to the urethra. This position of the urethra is important for the sudden elevation of intra-abdominal pressure to be transmitted to the proximal urethra (encouraging closure) as well as to the bladder (encouraging urethral opening). The improvement in posterior urethrovesical angle produced by urethral elevation aids continence with stress by preventing proximal urethral funnelling. Different types of posterior urethrovesical angles are shown in Fig. 52.2. Women with significant stress incontinence usually have pelvic floor weakness which may be sufficiently severe to allow genitourinary prolapse. Surgical cure of stress incontinence necessitates elevation of the proximal urethra to an intra-abdominal position to improve pressure transmission and improve the posterior urethrovesical angle.

Current research suggests that the pelvic floor and urethral sphincter muscle weakness is due to muscle denervation. This denervation is a normal accompaniment of ageing and appears to be increased by pregnancy and parturition.



**Fig. 52.2:** Types of 'posterior urethrovesical angles' seen on lateral urethrocytography. The presence or absence of the angle is merely a radiological sign of a good or incompetent internal urethral sphincter

Any factors which produce an acute or chronic rise in intra-abdominal pressure may precipitate stress incontinence. Intra-abdominal tumours should not be overlooked. Obesity and a chronic smoker's cough are common associations with stress incontinence.

### Detrusor Sphincter Dyssynergia

This represents a small proportion of the sphincter dysfunction group. Detrusor contraction is accompanied by urethral sphincter contraction instead of relaxation, resulting in voiding difficulty. The cause of this is generally neurogenic.

## INVESTIGATION OF URINARY PROBLEMS

### History and Examination

A careful history is necessary in the investigation of urinary problems. *Examination of the patient should include a full neurological examination*, particularly if bladder dysfunction is suspected. Vaginal atrophy or infection should be noted. History and examination may, however, be of little help in determining the precise cause of incontinence.

### Examination of The Urine

Urine microscopy and culture is essential in the investigation of urinary problems. Repeat examinations may be required to exclude contamination. The finding of glycosuria should be followed up by a glucose tolerance test.

### Uroflowmetry

This involves measurement of the urinary flow rate. The normal adult voids at a maximum rate greater than 20 ml/second resulting in complete bladder emptying. Reduced urinary flow and incomplete bladder emptying indicate detrusor and/or sphincter dysfunction. A patient with incomplete bladder emptying will probably complain of frequency rather than voiding difficulty.

### Cystometry

In its simplest form, cystometry employs a fluid-filled manometry system to record intravesical pressure during bladder filling. Isotonic saline at body temperature is infused into the bladder at 50 ml/min through a urethral catheter. In the normal bladder, a first sensation of the desire to void is recorded at 100-250 ml. Capacity is

generally recorded at 450-750 ml. The intravesical pressure rise during filling to capacity is not normally more than 10 cm of water. Detrusor instability is defined as a pressure rise of at least 15 cm water during filling cystometry when the patient is trying to inhibit micturition. The intravesical pressure recorded clearly represents the cumulative recording of detrusor-generated pressure and intra-abdominal pressure. To establish the intrinsic detrusor muscle pressure, a balloon catheter is placed in the rectum to record intra-abdominal pressure and a graphic recording of intravesical, intra-abdominal and detrusor pressures (intravesical minus intra-abdominal pressure) is made. Thus any pressure rise recorded by the detrusor muscle recorder will represent detrusor muscle activity.

Microtip pressure transducers are now available. These allow more provocative manoeuvres to be performed by the patient during cystometry (e.g. walking) than is possible with a fluid-filled system.

Radiological screening of filling cystometry and micturition has been developed and may be recorded on video tape (videocystourethrography, VCU). Inevitably, greater sophistication involves greater expense and technical expertise. Examples of filling cystometrograms are shown in Figures 52.3A to C.

### Urethral Profilometry

A recording of the closure pressure along the length of the urethra is made with a pressure transducer. Correlation of sphincter weakness with reduced closure pressure is possible, aiding the diagnosis of urethral sphincter weakness and choice of management.

### Electromyography

Electromyography is now being used more frequently to gain an understanding of the neuromuscular interactions between bladder, urethra and pelvic floor. It seems likely that much of the lower urinary tract dysfunction previously described as idiopathic has a neurogenic origin.

### Cystourethroscopy

Cystourethroscopy, which is generally performed under local anaesthesia, is an important part of lower urinary tract assessment. The exclusion of inflammatory lesions is particularly important. Bladder tumours are also occasionally found.

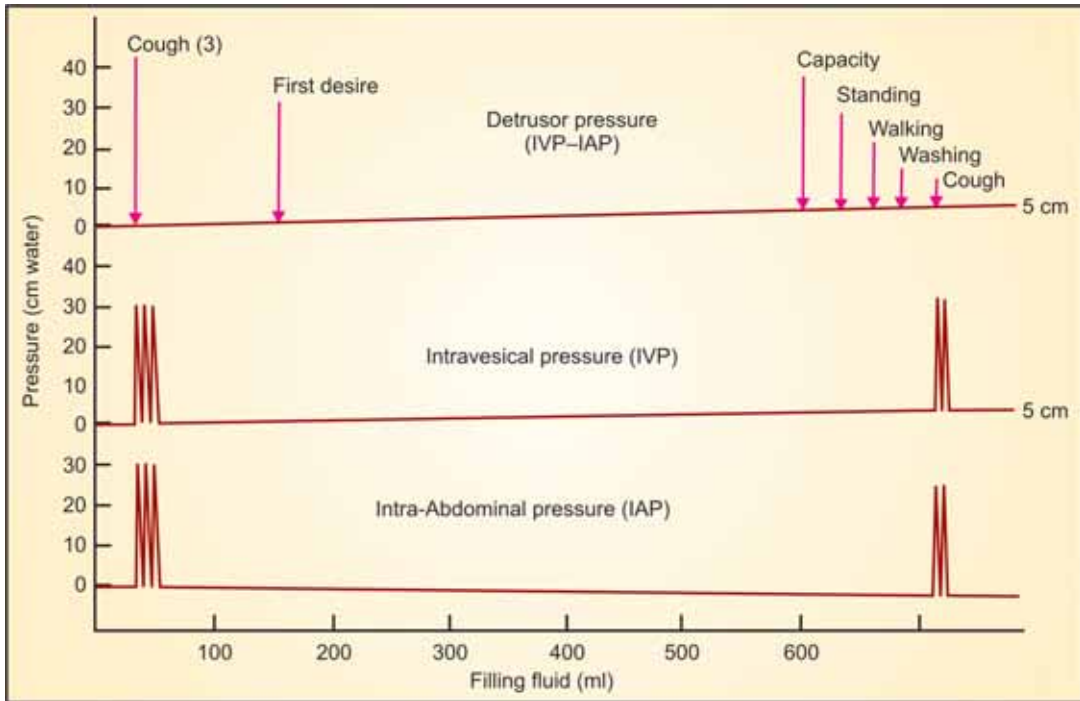


Fig. 52.3A

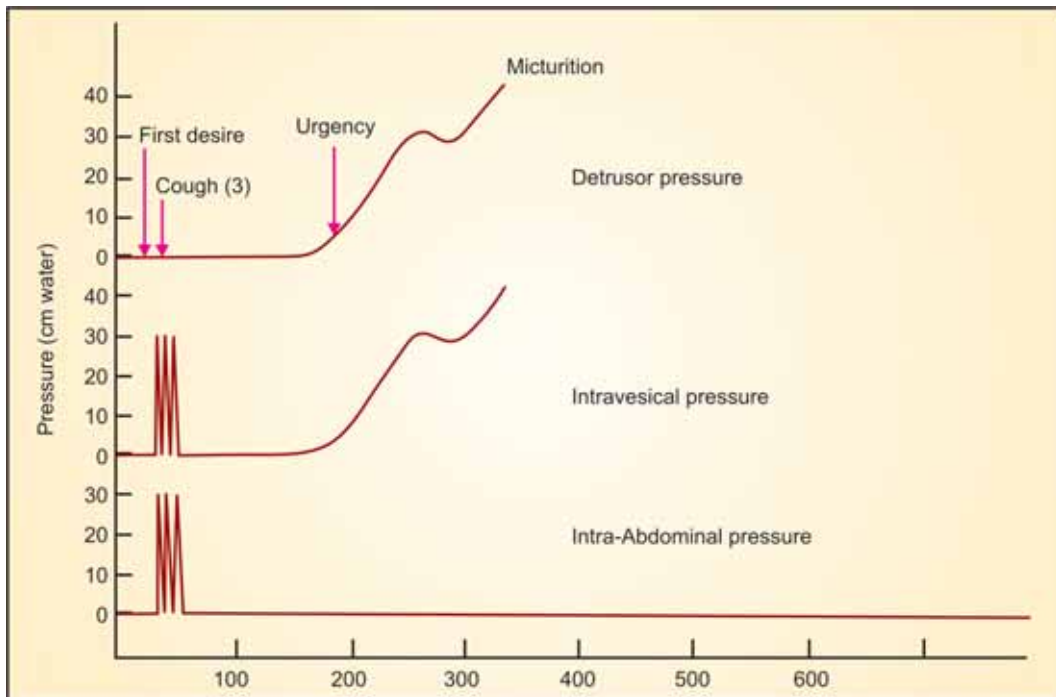


Fig. 52.3B

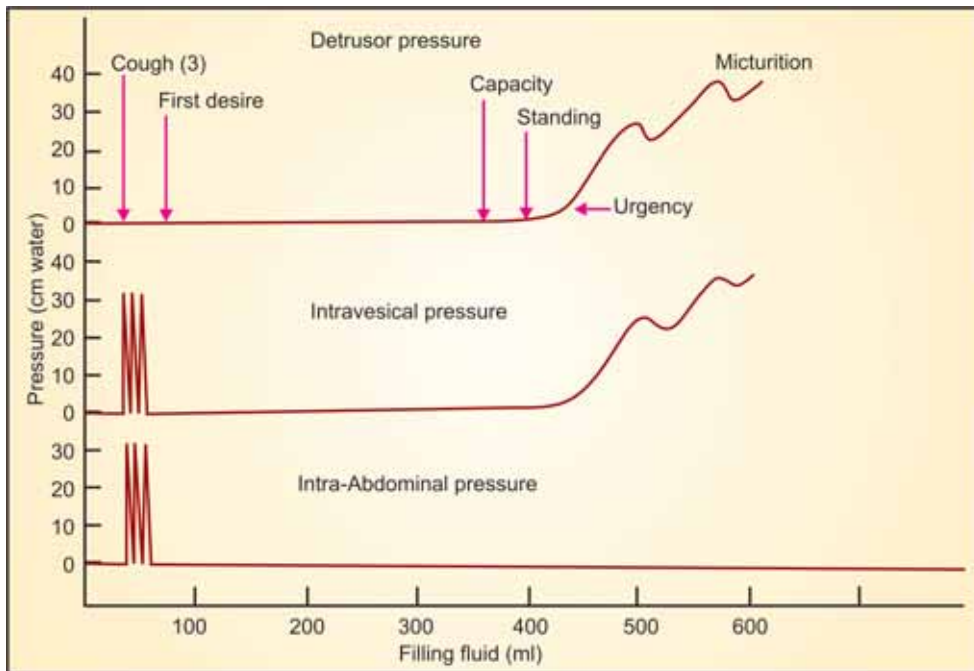


Fig. 52.3C

**Figs 52.3A to C:** (A) Normal cystometry. The diagram illustrates a recording of a three-channel filling cystometry. Fluid is infused at 50 ml/min. Three coughs are recorded by the rectal catheter (intra-abdominal pressure) and the intravesical catheter recorders, but there is no increase in the detrusor pressure. The 'First desire' to void is noted here after infusion of 175 ml which is normal. There is no significant rise in detrusor pressure on filling to capacity (5 cm water). No detrusor contractions are recorded when provocative actions (standing, hand washing) are performed, (B) Detrusor instability. In this recording, the 'First desire' to void is noted early (30 ml). After infusion of less than 200 ml into the bladder, the detrusor pressure rises and is followed by involuntary micturition, (C) Detrusor instability with provocation. In this recording, the detrusor muscle is stable to a reduced capacity of 375 ml in the supine position. However on standing detrusor instability is demonstrated with involuntary micturition

### Radiological Studies

Lower urinary tract symptoms may be a sequel to upper urinary tract disease which may be detected by intravenous urography. Intravenous urography is also important to exclude congenital abnormalities such as duplicate ureters. X-ray of the lumbosacral spine is pertinent to women with a history of backache accompanying lower urinary tract dysfunction to identify intervertebral disc lesions and the cauda equina syndrome.

Lateral urethrocytography is discussed below.

### Ultrasound

Ultrasound is useful in estimating postmicturition residual volume, and in assessing the bladder neck and the surrounding areas.

Estimation of residual urinary volume is done by measuring the three diameters in two perpendicular planes and multiplying the product of the three by a correction factor of 0.625, since the bladder is not spherical until full. The bladder neck can be evaluated by abdominal, vaginal, rectal or perineal probes. Descent of the bladder neck, bladder wall thickness, urethral cysts, etc. can be demonstrated.

### TREATMENT OF URINARY PROBLEMS

#### Infection

Urinary infection should be treated with appropriate antibiotic therapy. Recurrent or chronic cystitis should be treated with long-term (3-6 months) low-dose antibiotics. Urethritis should also be treated with long-



term low-dose antibiotics accompanied by urethral dilatation which may need to be repeated from time to time. Atrophic urethritis responds dramatically to topical oestrogens in its early stages but thereafter urethral dilatation and antibiotic prophylaxis, in addition to hormone replacement therapy, are necessary.

### Detrusor Dysfunction

Detrusor irritability or instability will generally disappear if the infection precipitating the disorder is treated. A local or generalised neurological disorder should be managed appropriately. Idiopathic detrusor instability is best managed in the first instance by a bladder retraining programme ('bladder drill') which will produce good urinary control in 80 per cent of patients, particularly when they are well motivated. It is best started with a period of hospitalisation. If bladder retraining is not successful in inhibiting reflex bladder contraction, the programme may be supplemented by drug therapy. Oxybutynin or propantheline are the most effective drugs but, like all anticholinergic drugs, produce unwanted side-effects at therapeutic doses. Most women tolerate the side-effects if the therapy is effective. Antidepressant agents like imipramine may also be useful in decreasing bladder contractility.

Hypotonic detrusor dysfunction may be treated with distigmine bromide. Cholinergic side-effects may, however, be intolerable and self-catheterisation may have to be used intermittently.

Occasionally bladder dysfunction is refractory to treatment. Urinary diversion is the choice of a few women who are prepared to undergo the major surgery involved and the inconvenience of a stoma bag thereafter.

### Sphincter Dysfunction

A large proportion of women who leak urine with stress are unable to adequately contract their pelvic floor and voluntary urethral sphincter muscles. Pelvic floor physiotherapy is designed to strengthen these muscles by voluntary contraction (Kegel's exercises), often with the aid of electrical stimulation. This treatment produces satisfactory control in many women, particularly when the stress incontinence is not severe and precludes the need for surgery.

*Surgery for stress incontinence essentially provides an increased resistance to urinary outflow by producing a*

*mechanical obstruction in the urethra under stress conditions. It cannot replace the muscular weakness, which will remain forever. Surgery may be undertaken by the vaginal or abdominal approach (see below).*

## INCONTINENCE OF URINE

A woman who complains of an uncontrollable escape of urine, or of feeling constantly wet, sometimes confuses vaginal discharge with urine. The characteristic odour of the latter is one of the guides in distinguishing the two. There are four types of urinary incontinence: continual (true); overflow; urge; and stress.

### Continual Incontinence

This is also described as true incontinence. In this condition, the urine flows continuously by day and night. It is caused by some form of urinary tract fistula, either acquired or developmental, the latter including ectopia vesicae and aberrant ureter.

### Overflow Incontinence

This occurs as the sequel to prolonged and neglected retention. Its mechanism is not certain but incontinence occurs when the pressure in the bladder overcomes the urethral resistance; there may also be compensatory detrusor hypertrophy.

### Urge Incontinence

Urge incontinence is a common problem, frequently confused with stress incontinence but essentially different in nature and aetiology. In *genuine stress incontinence*, bladder function is completely normal but there is urethral sphincter dysfunction (see above).

In urge incontinence, the sphincter mechanism is normal but is overpowered by abnormal activity of the bladder, the detrusor muscle of which is hypertonic, oversensitive or outside the voluntary control of the central nervous system. Ordinarily the patient is continent but once she experiences a desire to void, the bladder escapes from inhibition and contracts so strongly that it opens its urethral sphincter. So, immediately after the urge to void occurs, the woman has 'to run to avoid an accident'. If she is too late, the bladder empties itself in part or whole. Diurnal frequency is an inevitable accompaniment and sometimes there is nocturnal frequency as well, especially if the woman has insomnia.

The problem is one of 'bladder irritability', the causes and treatment of which are described above.

The diagnosis of urge incontinence rests primarily on the fact that the leakage of urine occurs in relatively large amounts (not drops) and is heralded by a desire to void. However, it can be extremely difficult to assess because the woman's description is often muddled. Moreover, a bladder detrusor which is hypertonic, unlike the normal one, is stimulated to activity by movement of the body. So when a patient says that the urine escapes on changing position on rising from a chair, for example, it is easy to assume that she has stress incontinence.

In long-standing cases, bladder sensation may also be lost, so the subject is unaware of fullness or emptiness and may suffer a constant involuntary escape of urine. This can then be mistaken for stress incontinence, or incontinence from a fistula.

The assessment is made more difficult by the fact that it is not uncommon for a woman to have a mixture of stress incontinence and urge incontinence, the latter sometimes developing from a habit of frequent voiding adopted to limit the former. For these mixed types it is generally best to re-educate the bladder and to cure the urgency first. The stress incontinence is then treated surgically and bladder discipline continued post-operatively.

### Stress Incontinence

#### *Definition and Clinical Features*

Stress incontinence means the escape of urine through the urethra when the intra-abdominal (and therefore intravesical) pressure is raised by a sudden movement, coughing, laughing, walking or, in certain cases, even turning in bed. In extreme cases, it requires a rise in bladder pressure to only 20 or 30 cm of water to cause a leak; in the mildest, the pressure may have to be raised to 70 or 80 cm of water. The amount of urine lost at any one time is usually *only a few drops* and this is a feature important in the diagnosis.

The frequent and repeated small leaks lead to soreness and excoriation of the vulva, and necessitate frequent changes of underclothing or the constant wearing of a protective towel. In severe cases the woman's life becomes a misery; she feels a social outcast and avoids leaving the house.

Even more important, she ceases to buy new clothing and wears dark colours which will not show any stain.

All those things which matter most in preserving youth and health become unattainable so the woman sits at home, eats to comfort herself and becomes fat. It is noticeable that many women with stress incontinence are overweight but, as suggested here, this may be the result rather than the cause of the complaint.

In an effort to keep dry, most patients resort to emptying the bladder frequently. This, however, does *not* prevent stress incontinence and a few drops often escape when the bladder is apparently empty. It is indeed a feature of stress incontinence that it occurs irrespective of the degree of fullness of the bladder, although to cause leakage when the volume of urine is low, rather higher intravesical pressures are required.

### Demonstration of Stress Incontinence

Before accepting that a woman suffers from stress incontinence, it is essential to see the escape of urine when the patient coughs or strains. In this respect it should be noted that some women find it impossible to demonstrate incontinence except when they stand. It is therefore imperative that all women complaining of incontinence are examined both supine and erect. The character and timing of an observed urethral leakage also deserves analysis.

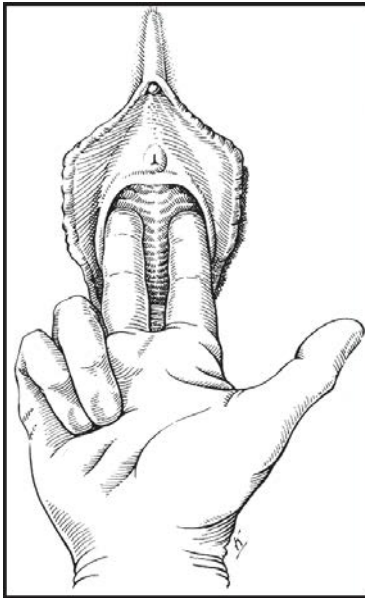
#### *Bonney Test*

This clinical test, illustrated in Fig. 52.4, is often said to have the object of seeing whether an uplift of the urethrovesical junction will stop the incontinence during coughing, so giving a guide as to the operation required. Victor Bonney himself, however, described the application of pressure, not uplift. A positive test merely shows that closure of the internal sphincter by pressure from the vagina controls the leak. It therefore has limited value in the assessment of urinary incontinence.

#### *Q-tip Test*

The Q-tip test detects urethral hypermobility and assesses the likelihood of response to surgery.

The patient is placed in the lithotomy position. A lubricated sterile cotton-tipped swab is passed through the urethra into the bladder and then withdrawn to the level of the urethrovesical junction. The axis of the urethrovesical junction at rest and after straining using a Valsalva manoeuvre is measured. If the cotton-tipped swab moves upward by more than 30° after straining, it



**Fig. 52.4:** Bonney's test for stress incontinence as described by the late Victor Bonney. Light pressure is applied immediately to the sides of the upper urethra and is directed forwards. There is no suggestion that the test involves 'uplift'. The effect of such pressure merely tightens or closes the internal sphincter and will, of course, control any form of urethral incontinence

indicates urethral hypermobility. A negative Q-tip test in a patient with previous failed surgery suggests genuine stress incontinence.

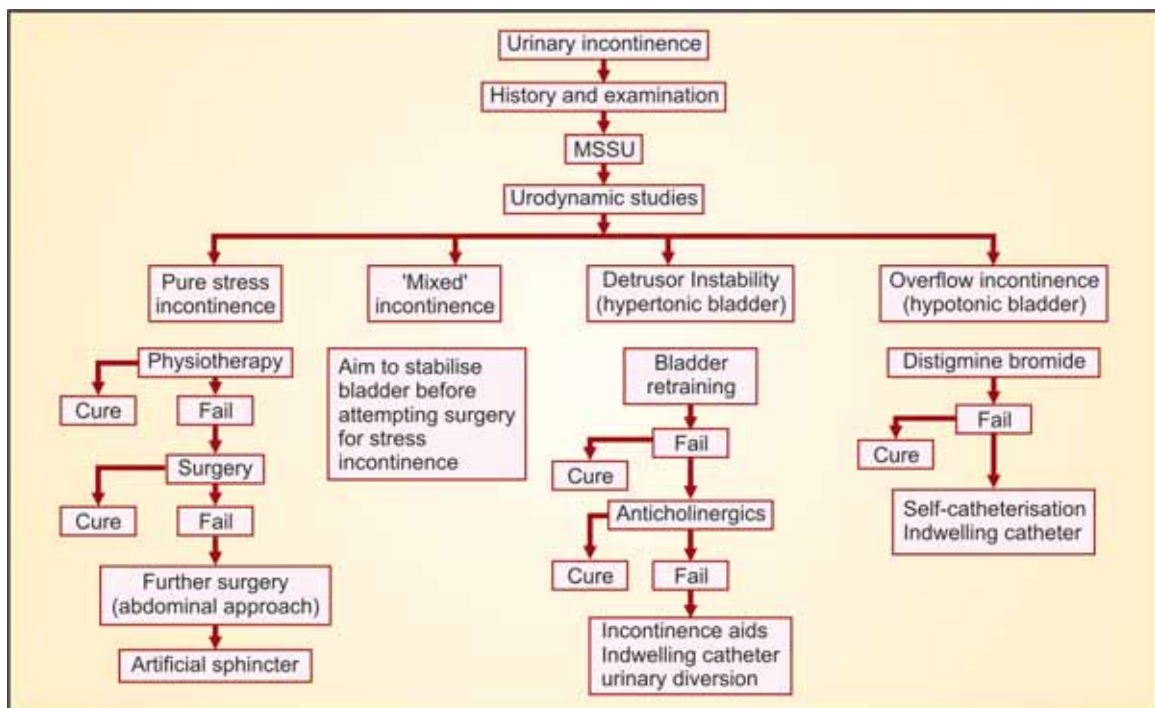
### Investigation of Urinary Incontinence

This has been discussed under the investigation of urinary problems; the management of urinary incontinence is summarised in Fig. 52.5.

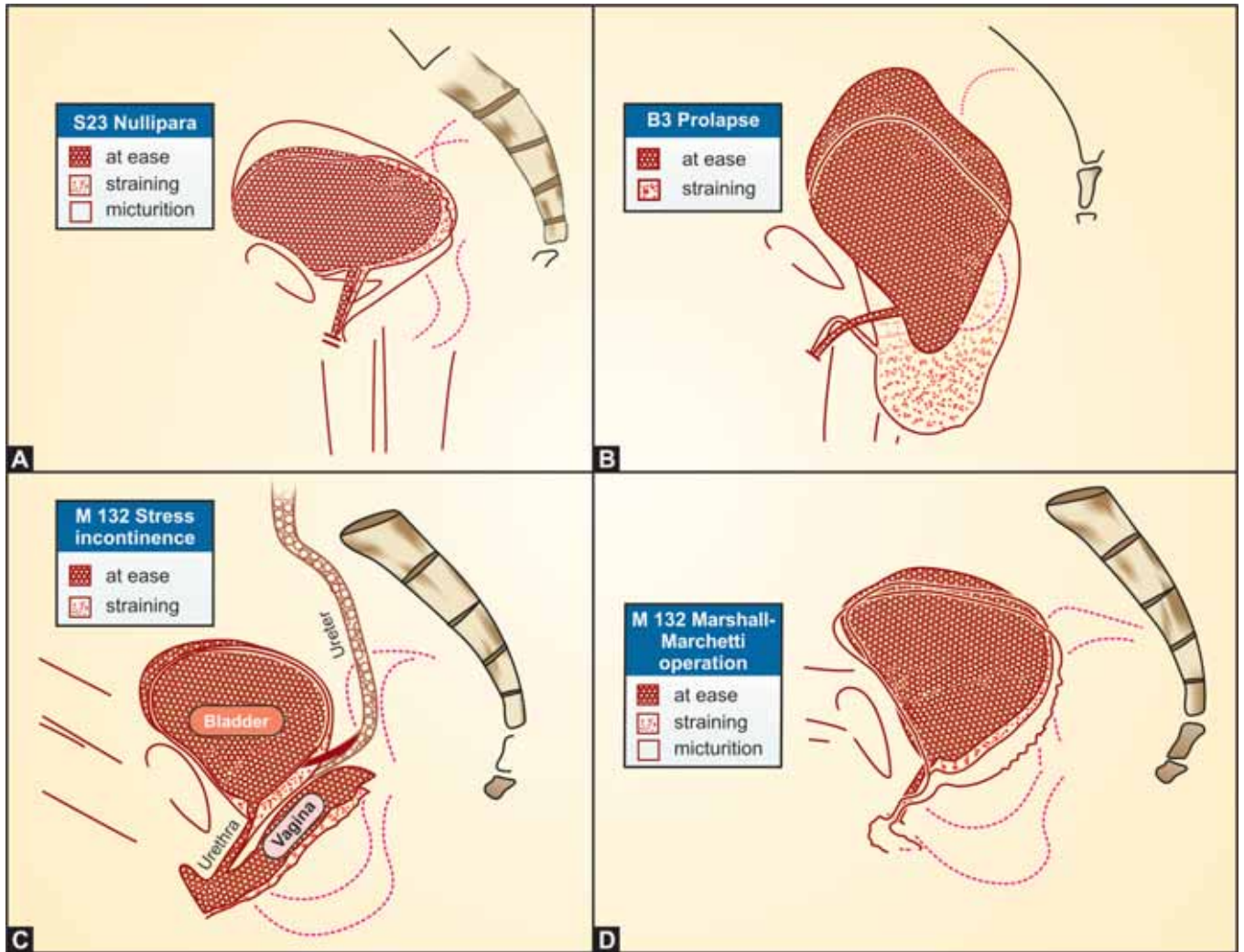
#### Radiological Findings

Lateral urethrocytography ('micturating cystourethrogram' or 'micturating cystogram') may be used to demonstrate urethral sphincter weakness in cases of suspected or proven stress incontinence. A radio-opaque medium is introduced into the bladder through a urethral catheter and lateral radiographs are taken at rest, under strain and with micturition.

During normal voiding the posterior urethrovesical angle is lost so that the floor of the urethra and trigone come into line and the bladder neck opens (Fig. 52.6A). In women who have an incompetent internal urethral sphincter, the posterior urethrovesical angle is also lost (Fig. 52.6C). In severe cases this feature is apparent even



**Fig. 52.5:** Management of urinary incontinence



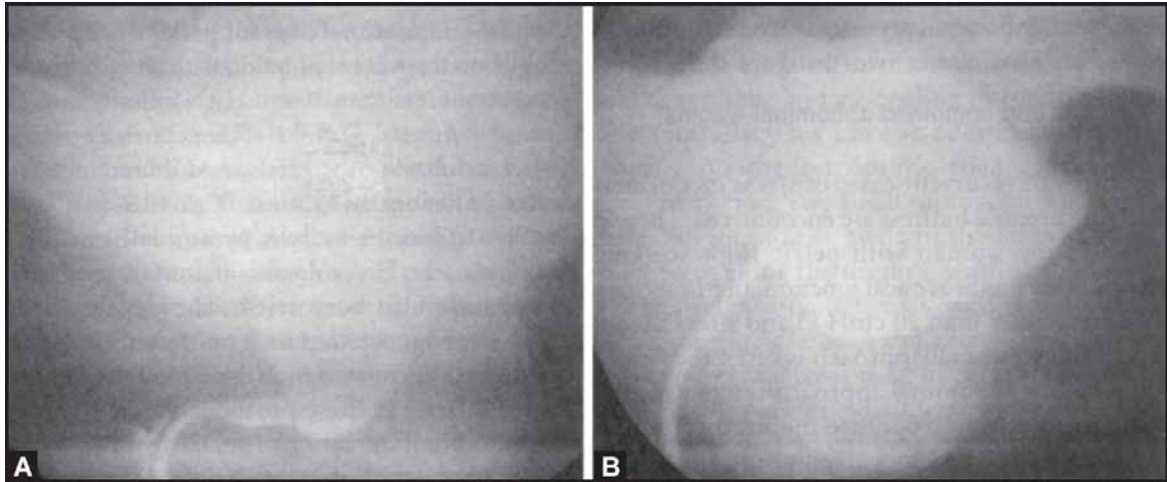
**Figs 52.6A to D:** Tracings of urethrocytograms to help in the interpretation of others, (A) Nulliparous woman with normal bladder function, (B) Multiparous woman with prolapse but not stress incontinence. The anatomy of the urethrovesical junction remains normal even when the patient bears down, (C) A case of urinary stress incontinence. A poor posterior urethrovesical angle is present when the patient is at ease but disappears when she strains, (D) The situation after a successful urethrocytostomy carried out in case (c). The anatomy of the urethrovesical junction is restored, meaning a competent internal sphincter; even on voiding the posterior angle does not fall away completely — a characteristic of successful operations of this type, (A, B, and C by permission of Mr Henry Roberts and the Editor, *J Obstet Gynaecol Br Emp*; and (D) by permission of the Editor, *Surg Gynecol Obstet*)

when the woman is sitting or standing quietly; in others it appears only with straining.

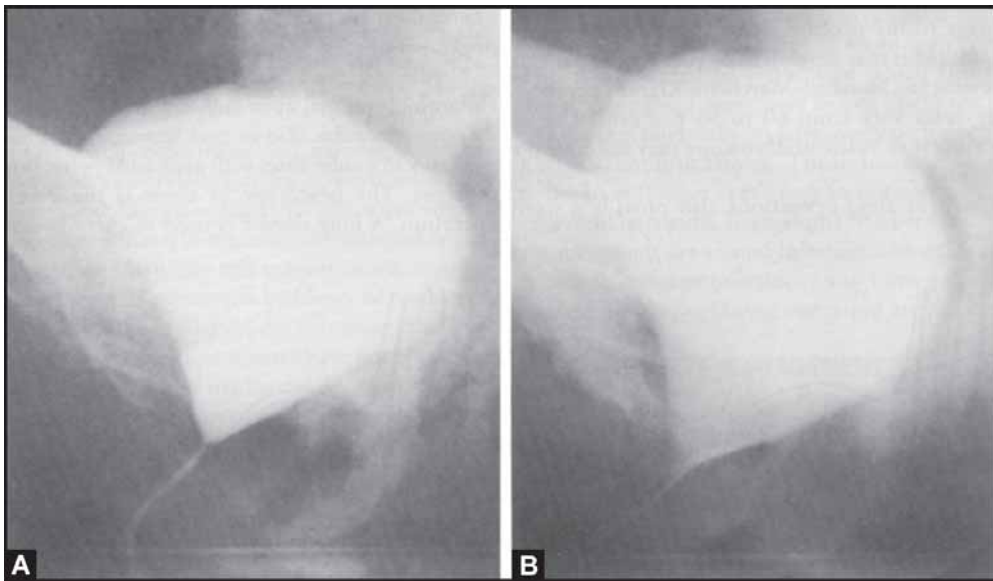
The lateral urethrocytogram is also useful in the assessment of the woman in whom surgery for stress incontinence was unsatisfactory. Figures 52.7 and 52.8 illustrate problems encountered after surgery and their recognition by cystourethrography.

#### *Selection of Patients for Detailed Urodynamic Studies*

A detailed history and examination, including urinalysis, of women complaining of urinary incontinence will not always determine the precise cause of the incontinence. Urodynamic studies should ideally be performed on all incontinent women, but this is not always possible. The



**Figs 52.7A and B:** The effect of a successful urethroplasty and internal sphincter plication operation as shown by lateral urethrocytography with the patient straining, (A) Before operation there is loss of the posterior urethrovesical angle and leakage past the internal sphincter as well as some cystocele. (B) After operation the anatomy and function restored to normal



**Figs 52.8A and B:** A failed Aldridge sling operation. The patient concerned, aged 75 years, had had two previous urethroplasty operations and prospects for cure by a sling seemed good until it was noted at operation that the abdominal fascia was very weak. The stress incontinence recurred within one month and these radiographs were taken 3 months after operation, (A) When the woman bears down the posterior angle, very poor at ease, virtually disappears, (B) During voiding there is no sign of the slight kink just below the urethrovesical junction which is a feature of successful operations

clinician must select those patients who would benefit from detailed urodynamic studies, if limited facilities are available, otherwise they would be overburdened. In general, surgery should not be performed without urodynamic studies when there are any symptoms suggestive of bladder dysfunction.

### Medical Management

This should always be tried as the first line of therapy. Kegel's exercises (*see* Chapter 58) strengthen the pubococcygeal and periurethral muscles producing an objective response in 21-80 per cent of patients. Biofeedback aids the response.

Pharmacological therapy often produces disappointing results and has significant side-effects on the autonomic nervous system but should be tried, especially in patients with mixed incontinence. Imipramine 25-150 mg/day increases the tone and may improve mild to moderate incontinence. Other drugs which have been used are  $\alpha$ -adrenergic stimulators such as phenylpropranolamine 25-150 mg/day.

The use of topical oestrogens thrice a week for 6 to 12 weeks has been associated with a subjective response.

### The Surgical Management of Stress Incontinence

As discussed earlier, surgery for stress incontinence essentially provides an increased resistance to urinary outflow by producing a mechanical obstruction in the urethra under stress conditions. Surgery may be performed by the vaginal or the abdominal approach.

#### Vaginal Approach

Traditionally, the primary surgical approach to stress incontinence has been vaginal. A urethral buttress operation should involve buttressing the urethra and bladder neck only with the pubourethral and pubovesical fascia (Kelly's sutures). The fascia should preferably be apposed with non-absorbable material, which provides support until fibrosis is complete. This should not be confused with the operation for repair of a cystocele, for an anterior repair involves mobilisation of the bladder from the cervix and supporting the bladder base. A urethral buttress, adequately performed, will cure stress incontinence in 60-90 per cent of cases but, in a proportion of these cases, the pelvic floor and urethral muscle weakness will be such that in time (as age-related weakness develops) stress incontinence will recur.

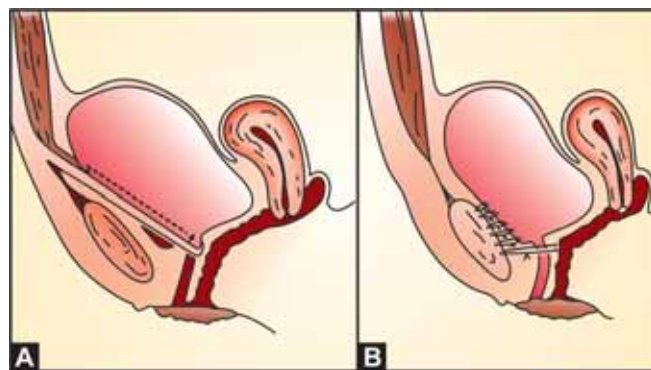
#### Periurethral Injection

Periurethral injection of glutaraldehyde cross-linked bovine collagen (Contingen) or polytetrafluoro-ethylene micropolymer (Urethria) is a simple day-care procedure, performed under local anaesthesia. These materials can be injected transurethrally using a cystoscope, or directed periurethrally. Contingen is easier to inject than Urethria, but being biodegradable it is broken down in 3-4 months and replaced by the patient's own collagen. The injection may need to be repeated in some patients. This procedure is suitable for mild urethral sphincter incompetence, both

primary and in case of failed previous attempts, especially in the physically frail, but is not suitable for excessive urethral hypermobility. The mechanism of action is to improve coaptation of the urethra at the level of the bladder neck, preventing the proximal urethra from opening when intra-abdominal pressure increases. Satisfactory results are obtained in two-thirds of cases.

### Abdominal and Combined Abdominal-vaginal Approach

A number of recurrent cases of stress incontinence following urethral buttress are encountered. Therefore in the young woman with pelvic floor weakness, hypermobile urethrovesical junction, urethral closure pressure greater than 20 cm H<sub>2</sub>O and stress incontinence, an abdominal approach is often the primary method. The abdominal approach is likely to prove and remain effective because the urethral support provided is attached to a fixed point and will not descend with progressive pelvic floor weakness. In the Marshall-Marchetti-Krantz operation, the paraurethral fascia is attached to the periosteum of the pubis and the symphyseal cartilage (Figs 52.9A and B), whilst in a Burch colposuspension operation the paraurethral fascia is fixed to the ipsilateral ileopectineal ligament. Both operations involve surgery in the cave of Retzius which may be complicated by damage to the profuse vasculature in the region. Osteitis pubis may develop in 2-5 per cent of patients following the Marshall-Marchetti-Krantz operation. Cure rates vary from 60 to 90 per cent. Use of intraoperative video-urethroscopy may improve the outcome.



**Figs 52.9A and B:** The principles of two operations for stress incontinence not cured by more simple procedures, (A) A urethral sling operation: in this case the Aldridge sling technique is illustrated, (B) The Marshall-Marchetti-Krantz operation (urethro-cystopexy)

Urethral sling operations also provide a fixed support. These are suitable for patients with a hypermobile urethrovesical junction with a urethral closure pressure of less than 20 cm H<sub>2</sub>O. Initially fascia lata was used (Goebel-Stoekel-Frangenheim operation). Other autologous materials used include the rectus fascia (Aldridge operation, Fig. 52.9A), round ligaments, gracilis muscle, pyramidalis muscle and rectus muscle. Heterologous materials such as dura mater have also been tried. The development of synthetic sling materials such as Marlex mesh, silastic bonded to dacron and mersilene mesh has increased the popularity of these procedures.

Abdominal operations involving more complex surgery have the inherent danger of injury to the vascular and nerve supply of the bladder, and are therefore associated with more frequent complications. Urgency and urge incontinence may follow colposuspension particularly, and on occasions this may be refractory to treatment. Such complications are less likely to occur with the vaginal approach to surgery. In modern gynaecological urological practice, a careful explanation to the patient of the risks and prognosis of each proposed operation is essential.

Needle-suspension procedures using the combined abdominal-vaginal approach are an alternative to the open retropubic bladder neck suspension methods, especially in milder cases with associated pelvic organ prolapse. The prototype of these is the Pereyra operation. A long needle is used to carry two sets of suture from the abdominal fascia to the perivesical fascia, suspending the bladder neck on a swing. The Raz technique is a modification of this method in which a wider dissection of the endopelvic fascia is carried out and sutures include this fascia and a part of the vaginal wall. These operations are quick and easy to perform and have a low morbidity. It is easy to combine them with other vaginal procedures, e.g. hysterectomy or anterior colporrhaphy.

An artificial urinary sphincter can be implanted as a last resort in cases of urethral sphincter incompetence where conventional surgery has failed and the patient is not willing to accept her lot of continued incontinence or catheter drainage, nor is she willing for a diversion procedure. If the bladder capacity is normal with no infection, and the detrusor muscle and upper tracts are normal, a success of 66 per cent can be expected.

### *Endoscopic Bladder Neck Suspension*

Endoscopic techniques are suitable only for those patients who have not undergone previous surgery. The Stamey operation consists of needle insertion of a suture on either side of the bladder neck, which anchors the pubocervical fascia to it. A No. 2 Prolene suture is used.

The Burch colposuspension, paravaginal suspension and suburethral sling operations can be performed laparoscopically. The advantage of endoscopy is that it is minimally invasive and recovery is faster. The visibility and magnification at surgery is also better. However the incidence of bladder and ureteric injury is higher. An intraoperative check cystoscopy ensures that sutures have not been passed through the bladder inadvertently. At follow-up of 1-2 years, success rates of 85-90 per cent have been reported but long-term results are around 70 per cent.

### *Tension-free Vaginal Tape*

This procedure, introduced by Ulmsten, is the latest addition to the wide range of techniques for the treatment of female stress urinary incontinence. Unlike conventional techniques, the tape is positioned under the mid-urethra without tension. This restores the function of an intact pubourethral ligament and may also lead to a reflex stabilisation of the proximal urethra, as evidenced by the fact that patients who showed large funnelling of the bladder neck before surgery did not show this later.

The procedure is carried out under local anaesthesia by injecting 140 ml of sterile water mixed with local anaesthetic and adrenaline retropubically and paraurethrally. This has the additional benefit of opening up the retropubic space and causing vasoconstriction. Two small suprapubic incisions are made. An incision is made in the anterior vaginal wall 1.5 cm along the urethra, starting 0.5 cm from the external meatus. The tissue is dissected laterally towards the pubic bone. A straight inserter introduced into a Foley catheter is used to control the position of the urethra and the bladder.

The 'tape' is a 40 cm long, 10 mm wide prolene gauze covered with a plastic sheath fixed to two disposable bowed needles. These are inserted through the urogenital diaphragm between the levator muscle and the arcus tendinous fascia, through the retropubic space and the abdominal wall. Concomitant cystoscopy ensures that

the bladder has not been perforated. The tension on the tape is adjusted while the patient coughs and the plastic sheath removed. The patient does not receive a transurethral catheter unless there is residual urine of more than 100 ml. This is confirmed by ultrasound which also rules out a retropubic haematoma before discharge. This technique is minimally invasive, easily performed and has few complications. These include bladder perforation (5.4%), urge incontinence (5.1%) and retropubic haematoma (0.8%). Rare complications are wound infection, obturator nerve irritation and tape rejection. Long-term data on the success of this promising operation are awaited.

### Postoperative Management

The patient operated on successfully for stress incontinence almost inevitably suffers postoperative retention of urine. If she does not, a cure is most unlikely because it means that the internal sphincter has not been tightened or supported sufficiently. Efforts by the patient to void in the face of difficulty and attempts to catheterise her in the ward carry a real risk of injury to the operation site. This risk, as well as that of overlooking incomplete emptying of the bladder, is excluded by routine insertion of a self-retaining catheter at the conclusion of every operation for urethral incompetence. The catheter, either suprapubic or urethral, should not be removed for 5 days. Even then the patient may find it difficult to empty the bladder. If she does not, the operation will almost certainly fail. If she does, the catheter may have to be allowed to drain continuously for a further 2 or 3 days. Prophylactic antibiotic therapy may or may not be given according to individual preference. All infections should, of course, be treated immediately and effectively with the appropriate antibiotic.

Physiotherapy in the form of Kegel's exercises and biofeedback methods, or even digital palpation have been recommended. While these methods on their own may be inadequate to treat stress incontinence, they may be useful as adjuvant methods to improve long-term cure rates after surgery.

### Pregnancy After Cure of Stress Incontinence

The majority of women are approaching the end of the childbearing era by the time they undergo surgery for stress incontinence. The effects of pregnancy and labour following surgical treatment of stress incontinence have

not been well studied, but parturition is considered to involve a risk of disturbing the fibrous tissue around the urethrovesical junction. Because of this, delivery by elective caesarean section is generally recommended, irrespective of the type of operation which cured the urethral incompetence.

## ENURESIS

### Aetiology

Nocturnal incontinence of urine (bed-wetting) is the rule in children, until they have learnt to inhibit the automatic action of the bladder during sleep as well as during consciousness. It continues for a variable number of years and can persist in the adolescent and in the adult. Sometimes it is 'secondary' in that it represents the breakdown of an acquired control, usually under stress. It is then closely related to functional urge incontinence. Many bed-wetters have diurnal urgency.

In children, the complaint is more often seen in boys than girls; in either sex, it tends to be familial and its causes are as follows.

### Natural Variability in Age

There is a natural variability in the age at which control is developed; this is dependent on the time of maturation of the nervous system. Enuresis persists until the age of 5 years in 10 per cent of children and to puberty in 1 per cent.

### Organic Disease

Conditions which may underlie or contribute to enuresis include lesions of the central nervous system, urinary tract infection, and diseases causing polyuria. These are more often found in adults than in children. In the latter, an organic basis is found in less than 1 per cent of cases. In girls, an intermittent leak from an accessory ureter can be mistaken for enuresis.

### Psychological Disturbances

These are the most important of all causes, and primary enuresis is nearly always the result of a combination of delayed maturation with a variety of psychological and environmental factors. The latter include an unhappy and insecure home background, and lack of parental care and guidance in the conditioning of the bladder reflex.



Once established, and depending on its handling, enuresis can persist as a means of attracting attention or of avoiding unwanted occupations and responsibilities.

### Subnormal Bladder Capacity

Although it is sometimes alleged, the capacity of the bladder is never organically small; the detrusor muscle is merely intolerant of large volumes, and behaves in exactly the same manner as is described for the irritable bladder.

### Management and Treatment

The investigation and treatment of enuresis in the adult is the same as for the irritable bladder already described. What follows applies mainly to enuresis in childhood and adolescence, although some of the measures and drugs mentioned can be useful in adults. When enuresis in a child persists for an unreasonable time and despite treatment, full investigation is indicated to exclude an organic basis. Otherwise it is best avoided lest it exaggerate the problem in the mind of the sufferer. If urinalysis and physical examination reveal no abnormalities, the symptoms should be treated on the assumption that its cause lies in the psyche. The fact that it is psychological makes treatment difficult and explains why 30 per cent of 'cures' are followed by relapse.

- *General approach:* It is best not to worry the child, for if the problem can be disregarded a spontaneous cure is encouraged. The fact that spontaneous cure is always likely makes it extremely difficult to claim success for any remedy. It is reckoned that when general measures and drugs (not including the bed buzzer) fail, 50 per cent of enuretic children cure themselves by the age of 9 years and at least another 25-30 per cent by the age of 14 years. It is most exceptional for the complaint to persist after the age of 19 years. So exhortation at night and scolding in the morning are to be avoided. Some say there should be no comment on whether the bed is wet or dry; others say that comment on success gives encouragement to a child who is probably losing confidence and becoming distressed inwardly.

Children and their parents certainly deserve help and support and, as time goes by, it is not enough to give an assurance that the girl will 'grow out of the habit'.

- Correction of the background of unhappiness, insecurity and nervous stress
- Bladder discipline during the day
- Avoidance of drinking any fluid for 3 hours before retiring
- *Drugs:* Desmopressin is the drug of choice. Propantheline, amitriptyline and imipramine are also used. However the benefits of drug therapy are often not sustained over a period of time after discontinuation. Great caution is necessary in increasing the dose or in continuing medication for a long time because imipramine can cause fatal poisoning and there is no specific antidote to it.
- Waking the child to empty the bladder every 3-4 hours. The resentment to interruption of sleep can also have a good disciplinary effect.
- Electric bed buzzers act in a similar way and are activated by the initial escape of water. They should not be used for children less than 7 years of age and need to be put in place regularly for not less than 3 months. The results are good (a 75% cure rate is claimed) and long-lasting, but care is necessary to avoid their producing burns or shocks.
- Specialist psychiatric treatment.

### URINARY RETENTION AND DIFFICULTY IN MICTURITION

For an understanding of the causes and mechanisms whereby a woman develops retention of urine, the reader is advised first to review the physiology of voiding.

The classical gynaecological cause of urinary retention is an impacted pelvic tumour. In such a case the diagnosis is usually made clear by attention to associated symptoms, as indicated below.

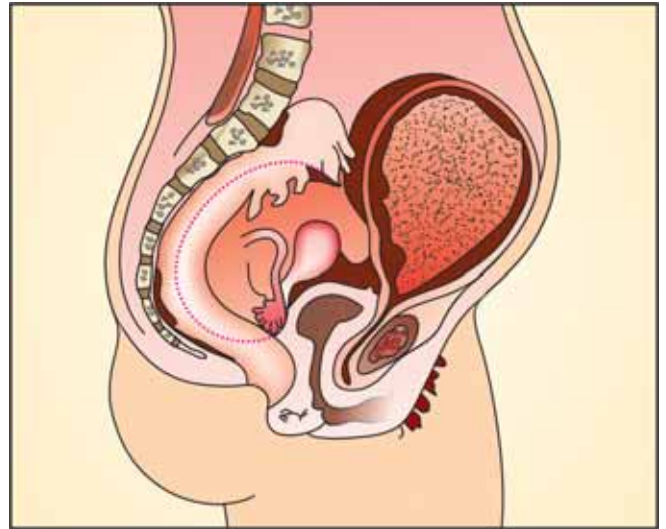
Retention + primary amenorrhoea	= haematocolpos
+ secondary amenorrhoea	= retroverted gravid uterus
+ menorrhagia	= uterine leiomyoma
+ no menstrual upset	= ovarian or broad ligament tumour
+ irregular bleeding	= threatened abortion from a retroverted gravid uterus or pelvic haematocele or pelvic abscess

### Causes and Mechanisms of Retention

Acute retention occurring under the above circumstances has long been explained by assuming that the tumour elevates the bladder base into the lower abdomen, thus elongating and stretching the urethra. Attenuation of the urethra, rather than direct compression, is thus held accountable for difficulty in outflow of urine. How did this concept arise?

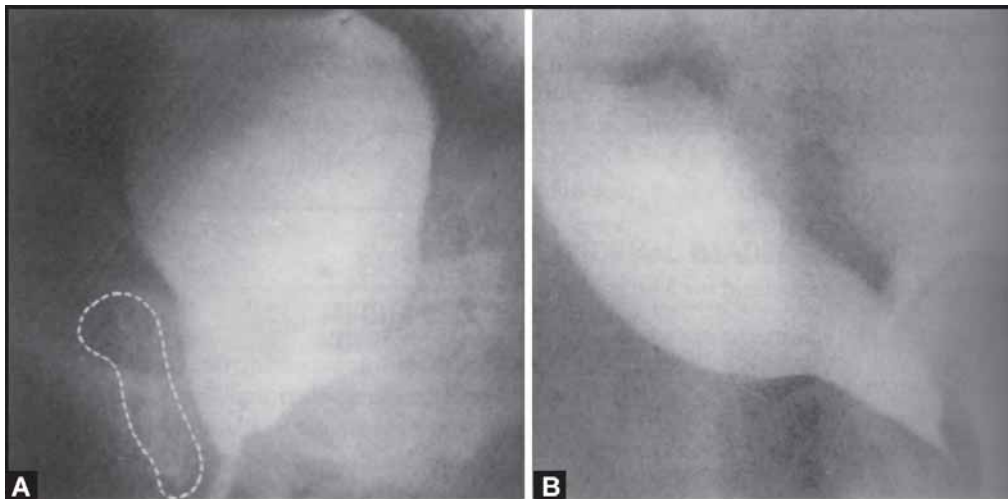
Schatz in 1870 and Halliday Groom in 1890 studied the pelvic anatomy of women dying from an impacted gravid uterus. Both emphasised that the urethra is *not* elongated in this condition and that the urethro-vesical junction remains at its normal level in the pelvis (Fig. 52.10). Despite careful documentation by these authors, their illustrations were misinterpreted by subsequent writers who, without any anatomical evidence, fostered the notion that retention is caused by attenuation of the urethra.

Lateral urethrocytography in women suffering from retention caused by an impacted gravid uterus or other pelvic tumours (Figs 52.11A and B) confirms the accuracy of the observation by Groom and Schatz, and also demonstrates the reason for retention. The urethrovesical junction remains in its normal pelvic position and the urethra is not elongated. The patient fails to void in these



**Fig. 52.10:** Drawings from a frozen section of the trunk of a woman who died as a result of acute urinary retention caused by impaction of retroverted gravid uterus (Schatz, R, *Arch'. Gynakol.*, 1870,1,469). Although the appearances at first suggest elongation of the urethra, it is the collapsed lower compartment of the bladder. The urethrovesical junction is *not* elevated and is in its normal position behind the symphysis pubis

cases because the tumour interferes with the opening of the internal urethral sphincter, and this shows



**Figs 52.11A and B:** Retention of urine caused by tumours impacted in the pelvis. The mechanism is *not* elongation of the urethra. Although the fundus of the bladder rises into the lower abdomen the urethrovesical junction is at its normal level behind the symphysis pubis. Voiding fails because, despite contraction of the bladder detrusor muscle, the internal sphincter cannot open properly — because of the pressure of the tumour from behind, (A) Retroverted gravid uterus (14 weeks' amenorrhoea); the urethra is marked by a catheter but the patient is trying to void, (B) Uterine leiomyomas impacted in the pelvis. The patient is trying to void but has only succeeded in getting a few drops of fluid into the upper urethra. The posterior urethrovesical angle is still present to some degree. (By permission of the Editor, *J Obstet Gynaecol BrEmp*)

radiographically by persistence of the posterior urethrovesical angle. Incidentally, retention of urine by this mechanism can be reproduced experimentally merely by packing the vagina tightly with gauze to produce an artificial tumour.

Retention of urine in the female can always be explained by one of four mechanisms.

*The Bladder Detrusor Muscle May Fail to Contract and Thus to Open The Upper Urethra*

This is the usual mechanism for retention after lower abdominal operations but happens whenever:

- The woman fails to contract the abdominal muscles as an initial trigger to voiding.
- There is inhibition of the detrusor muscle by emotional upsets such as hysteria, excessive modesty and fear.
- The excitatory nerves to the bladder are paralysed by disease of the central nervous system, or are injured during extensive pelvic operations (radical hysterectomy, for example).
- The bladder muscle becomes atonic from overstretching; this may result from neglect of retention of any kind.

*Interference with the Opening of the Internal Sphincter*

This mechanism for retention is seen in the following circumstances:

- When a tumour such as the retroverted gravid uterus, a cervical leiomyoma, an impacted ovarian cyst, or the foetal head late in labour, crowds the pelvic space: It is still too commonly stated that, in labour, the bladder is lifted up into the lower abdomen, and that this elongates and attenuates the urethra to cause retention. Radiography during labour shows that, although the fundus of the bladder does rise as the presenting part descends, the urethrovesical junction always remains at its normal level behind the symphysis pubis and the urethra is not lengthened. This is true no matter how long labour lasts and even when it is obstructed. This is the reason that obstetrical fistulas resulting from prolonged labour and pressure are always sited in the trigone of the bladder and not in the urethra.
- When the vagina is tightly packed for any therapeutic reason

- After operations which buttress the tissues behind the urethrovesical junction with the object of curing stress incontinence of urine
- When these tissues are made inelastic by disease such as cancer extending from the cervix and vagina.
- When a urethral sling is made too tight or urethrocytostomy is performed too enthusiastically (Fig. 52.12).

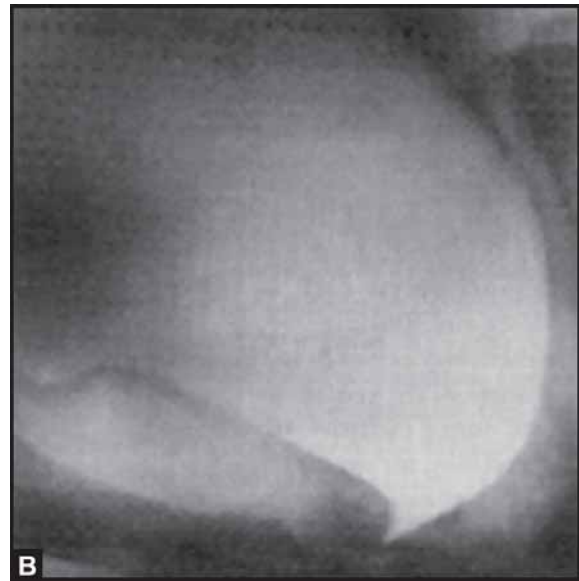
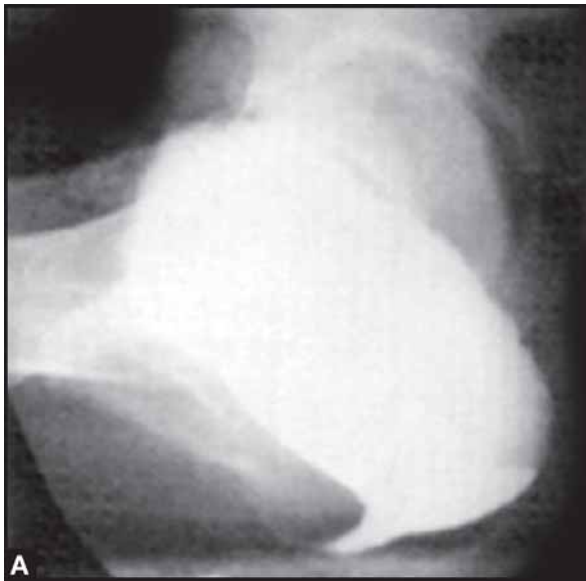
*Spasm of the Voluntary External Urethral Sphincter*

Despite proper contraction of the bladder detrusor and proper opening of the upper urethra, retention can still occur as a result of failure of the voluntary external sphincter to relax (Fig. 52.13).

This produces a typical radiological appearance which is identical with that seen during wilful arrest of the normal voiding act. Failure of the external sphincter to relax occurs in the following circumstances: nervousness and embarrassment of the woman; perineal



**Fig. 52.12:** The effect of urethrocytostomy in which the tissues were stitched too high behind the symphysis pubis. The urethrocytogram taken during attempts to void shows that the detrusor muscle is contracting but the posterior urethrovesical angle cannot fall away to open the internal sphincter fully. A very tiny stream of urine escapes with difficulty. Moreover, the base of the bladder forms a pouch below the level of the outflow and cannot be emptied. The patient in this case suffered postoperative retention for several weeks and thereafter had incomplete emptying. (By permission of the Editor, *Surg Gynecol Obstet*)



**Figs 52.13A and B:** Retention of urine caused by spasm of the voluntary external sphincter of the urethra, (A) Deliberate contraction of the external sphincter by a normal woman, instructed to stop voiding; she arrests the stream despite the fact that the detrusor has not stopped contracting, (B) An identical appearance in the case of a woman who suffered retention following perineorrhaphy; she is contracting the bladder which opens the upper urethra but she cannot relax the external sphincter

injuries during childbirth; operations on the perineum and perianal tissues; urethritis; and neurological disease.

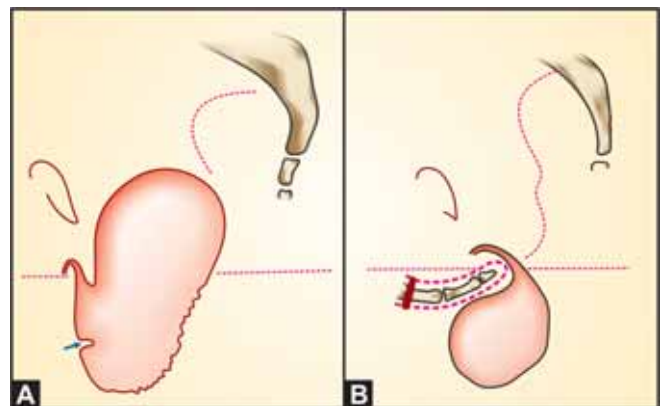
It appears that the compressor urethrae and the levator ani muscles act in unison, and lesions which cause the latter to go into spasm tend to have the same effect on the external urethral sphincter. This explains why vaginal operations rarely cause retention of urine *unless posterior colpoperineorrhaphy* is included.

#### Obstruction of the Urethra

This is the rarest mechanism of urinary retention and its causes include the following:

- Congenital atresia, valves or functional closure can cause gross distension of the bladder and ureters of the foetus *in utero*.
- Foreign bodies and calculi are rare because the urethra is so distensible.
- Stenosis of the urethra following injury or infection is rare (see Fig. 15.17).
- Stenosis of the vulva (see Fig. 15.22)
- Paraurethral cysts and abscesses
- Carcinoma of the urethra, vulva or vagina
- Angulation of the urethra. This occurs in cases of gross prolapse of the uterus and anterior vaginal wall

(see Figs 16.9 and 52.14). The more the patient strains, the more the angulation, so she learns to lift up the prolapsed tissue and thus straighten the urethra in order to void.



**Figs 52.14A and B:** Tracings of lateral urethrocytograms which show retention of urine caused by angulation of the urethra associated with procidentia. (A) During voiding the stream has to pass upwards and attempt to negotiate a sharp bend in the urethra. The arrow marks the hypertrophied interureteric bar. (B) In order to avoid the difficulty the patient has learned to insert a finger in such a position as to lessen the angulation of the urethra

## Treatment

The treatment of urinary retention and incomplete emptying of the bladder is primarily by catheterisation and then by dealing with the cause. Pelvic tumours require removal; management in the case of an impacted gravid uterus is described in Chapter 17. The treatment of postoperative retention, in which any of the first three causal mechanisms may be concerned, is described in Chapter 56. When the bladder is temporarily or permanently paralysed, the possible treatments are as follows:

- Continuous drainage to keep the bladder empty and to allow its walls to recover tone. Clamping the catheter with intermittent release does not hasten or facilitate the recovery.
- For residual urine, a catheter is passed once daily until the amount is less than 50 ml.
- Cholinergic drugs are most uncertain in their effects on the bladder detrusor muscle. If they stimulate it at all, they often cause incomplete emptying and thus deceive the attendants.
- *Change of posture:* This may be the only way to ensure evacuation of the bladder in women suffering from diseases of the central nervous system.
- *Expression:* Women can be taught to express urine by manual pressure over the lower abdomen. This is appropriate for certain cases of bladder paralysis.
- Dilatation of the urethra and of the urethrovesical junction may compensate for a weak detrusor action, or correct an operative overtightening.
- *Resection of the bladder neck:* This operation, sometimes recommended for idiopathic 'atony' of the bladder as well as for persistent retention, is rarely justified in women. It is usually unnecessary and carries a real risk of damaging the all-important internal sphincter. Idiopathic atony is generally the effect of nothing more than a habit of voiding too infrequently. It can be cured by disciplinary measures. Resection of the internal sphincter may, however, sometimes be indicated in the management of chronic retention in senile women suffering from true detrusor atrophy.
- *Intermittent self-catheterisation:* Some women are able to ensure adequate bladder emptying by self-catheterisation on a once- or twice-daily basis. Infection is rarely a problem with reasonable hygienic measures.
- An ileal loop bladder may be an option.

## URINARY TRACT INFECTIONS IN WOMEN

Urinary tract infections are among the most common bacterial infections in women and an important cause of morbidity.

### Incidence

During a life time more than half of the women will have UTI and upto 50 per cent of these will have another infection within a year.

3-5 per cent of women will have multiple recurrences and upto 20 per cent of women between 20-65 years age will have one attack of UTI a year. The prevalence of UTI is 5 per cent per year.

### Definitions

*Bacteriuria:* It is presence of small numbers of bacteria in urine and is asymptomatic.

*Significant Bacteriuria:* It is a condition which is symptomatic and the urine shows  $> 10^5$  colony forming units (cfu) per ml.

20-40 per cent symptomatic women may have a lesser count (previously a lesser count was labelled as contamination).

*Asymptomatic Bacteriuria:* 5 per cent of young and 20-40 per cent of older women may have a "cfu" of  $>10^5$  in urine without any symptoms. This is significant in pregnancy, instrumentation, renal operations etc and in such cases must be treated.

*Recurrent UTI:* About 12-27 per cent of women will have a recurrence of symptoms after resolution of a previous UTI. This may be relapse of same infection or reinfection. Reinfection is more common.

*Complicated UTI:* 3-10 per cent of women have UTI with a complicating factor like an indwelling catheter, stones, cancer, fistulae, diverticula and/or strictures.

- Functional complicating factors are neurogenic bladder, voiding dysfunction, reflux etc.
- Iatrogenic factors are catheter, stent, nephrostomy, etc.
- Miscellaneous causes are nosocomial, pregnancy, uraemia, diabetes, renal transplant, etc.

### Aetio-pathogenesis

Urinary infections in women results from complex interaction of host and micro-organisms. Women are more prone to UTI's due to the anatomy: short patulous

urethra and urethral proximity to vagina and anus. Urinary tract is sterile while vagina and anus have abundant of potentially pathogenic microbes (PPM), any weakening of host immunity may lead to these PPM's from vagina and anus to migrate into the urethra and cause UTI's (Fig. 52.15).

### Host Risk Factors

- Intercourse and meatal trauma
- Urethral massage
- Changes in normal vaginal flora due to lack of oestrogen and lack of lactobacilli
- Spermicidal use
- Diaphragms
- Increased age
- Impaired voiding
- Bad perineal hygiene
- Medical conditions like diabetes, obesity, anaemia, sickle cell trait, tuberculosis etc.
- Anatomical congenital anomalies
- Urinary tract caculi
- Bladder catheterisations
- Pregnancy induced physiological changes (vesico-ureteric reflux)
- Direct trauma to urinary – genital tract
- Prolapse

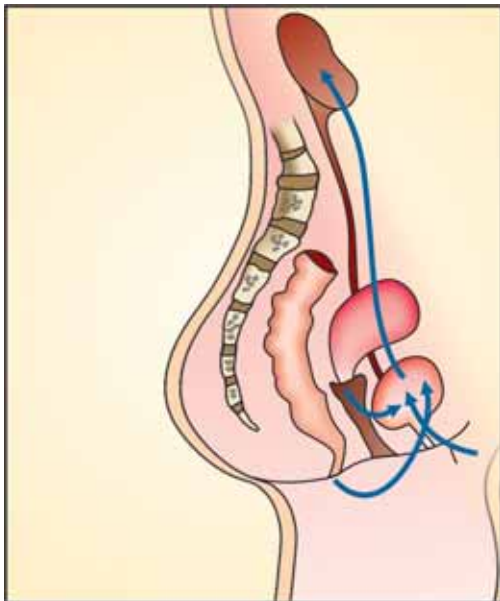


Fig. 52.15: Routes of Infection in UTI

### Bacterial Factors

Majority of the causative organisms for UTI are normal perineal flora which are potentially pathogenic microbes.

<i>E. coli</i> is the commonest	67-77%
<i>Proteus mirabilis</i>	5%
<i>Klebsiella pneumoniae</i>	7-8%
Coagulase negative staphylococcus	17%
<i>Staphylococcus aureus</i>	1-2%
Mycoplasma, Chlamydia and ureoplasma	rarely
<i>Pseudomonas aeruginosa</i>	nosocomial

### Diagnosis

#### History of Symptoms

- Frequency
- Burning
- Urgency
- Nocturia
- Dysuria
- Haematuria
- Supra pubic pain
- Loin pain
- Fever

### Investigation

- Clean catch mid stream urine for microscopic and culture sensitivity
- Culture is done on blood agar or McConkey agar plates.
- In uncomplicated UTI's urine culture sensitivity is the only test required
- In complicated cases
  - Ultrasound of upper urinary tract
  - IVU
  - Cystoscopy

### Treatment

Uncomplicated UTI's are treated with short course of antibiotics depending on culture sensitivity reports

### Common Antibacterials

Common antibacterials used are:

- Nitrofurantoin
- Quinolones (Cipro, Levo, Gati, Norflox, Zenfloxacin)
- Cephalosporins (Ceftriaxone, Cefotaxime)

- Aminoglycosides (gentamicin, tobramycin, amikacin)
- Trimethoprim – sulfamethoxazole (TMPSMX)

**Common Treatment Regimens**

*Single Dose Treatment*

Ampicillin	2 gm
Amoxicillin	3 gm
Nitrofurantoin	200 mg
TMPSMX	320/1600 mg

*3-Days Course*

Amoxicillin	500 mg	3 times daily
Ampicillin	250 mg	4 times daily
Cephalexin	250 mg	4 times daily
Nitrofurantoin	50 mg	4 times daily
	100 mg	2 times daily
TMPSMX	160/800 mg	twice daily
Ciprofloxacin	250 mg	twice daily
Levofloxacin	250 mg	once daily
Norfloxacin	500 mg	twice daily
Zenfloxacina	200 mg	twice daily

*Other Regimens*

Nitrofurantoin	100 mg	bed time	7-14 days
	100 mg	four times	7-14 days
Cefalosporins	250 mg	twice daily	5-7 days

*Aminoglycosides (Injectable)*

Gentamicin	80 mg	twice daily	5-7 days
Amikacin	500 mg	twice daily	5-7 days

**General treatment measures**

- Excessive oral fluids
- Voiding at short intervals
- Alkalisng agents (Potcitrae) for symptomatic relief
- Anti-spasmodics for pain
- Probiotics (Lactobacilli) orally
- Oestrogen creams and oral oestrogens (HRT) to menopausal women

**Special Conditions**

*Recurrent UTI's / Recurrent Cystitis*

- Almost 35 per cent women will have recurrence
- Test of cure i.e. urine culture and sensitivity is performed 1-2 weeks after completing therapy
- If there are 3 or more attacks in a 12 month period, continuous prophylaxis is indicated (Ciprofloxacin, Nitrofurantoin, trimethoprim or norfloxacin or cephalixin)
- Long term prophylaxis for 1 month reduces recurrence by 95 per cent in sexually active women
- Postcoital prophylaxis can also be tried.
- Cranberry or lingonberry juices decrease the risk of recurrent UTI's. Concentrated tabs of 200-750 ml are also used.
- Preventive measures are wiping, postcoital voiding, douching and timing of voiding

*Acute Cystitis*

Acute infection of bladder is often uncomplicated and the symptoms are dysuria (mild to severe), frequency and urgency. Some patients also have suprapubic pain and fullness. Diagnosis is suspected on clinical symptoms and confirmed by urine exam (routine, microscopic and culture). Rarely acute cystitis may also be due to Chlamydia.

*Acute Pyelonephritis*

This is a severe type of usually ascending infection of the kidney and clinically the patients complain of flank pain, chills and fever with dysuria, urgency and frequency.

Urinary tract abnormalities and urolithiasis and other obstructive causes are predisposing factors. Pregnancy is also a common risk factor. A urine culture and sensitivity with appropriate antibiotics is the line of treatment.

Women are more prone to urinary tract infections. This should not be ignored and treated early and aggressively to prevent complications.

Definitions and Staging of Menopause	862	Cancer Screening in Menopause	877
Effect of Oestrogen Deficiency	867	Various Types of Hormonal and Non-Hormonal	
Urinary Symptoms at Menopause	870	Pharmacological Agents Available	878
Bone Loss (Osteoporosis) and Fracture Risk	871	Use of Progesterone for HRT	880
Prevention and Management of Osteoporosis	873	HT in Special Circumstances	881
Menstrual Problems	875	Androgens in Menopause	882

## INTRODUCTION

Women all over world now have to spend almost 1/3rd of their lives in menopause years because average life expectancy is increasing. Average life expectancy for Indians is 68 years and 80 years for Americans, average age of menopause being 46-51years. So knowledge about menopause and various problems related to menopause is very important.

## History

About menopause not much was known till mid sixties of nineteenth century. It was only after this that work was started on menopause and relationship of ovary and hormones produced by ovaries were related to menopause and its related symptoms and then there were lots of studies on menopause and first International Menopause society was formed in 1978. After this the research on menopause was at a fast pace, but still gaps in knowledge and understanding are there and lots of awareness in clinicians and menopausal women is the need of the hour. It is not only quantity of life but quality of life of menopausal women which is important.

We have to go more for preventive aspects and lifestyle managements which should be started early in life i.e. just beyond thirty-five years itself.

## DEFINITIONS AND STAGING OF MENOPAUSE

Menopause is defined as the permanent cessation of menses. By convention the diagnosis of menopause is not made until the individual has had 12 months of amenorrhoea.

Menopause is not just cessation of menstruation it is “**Depletion of Ovarian follicles**” leading to decrease in ovarian hormones.

Menopause is thus characterised by the menstrual changes that reflect oocyte depletion and subsequent reduction in ovarian hormone production. However,



the manifestations that occur around the time of menopause are caused by the underlying ovarian changes, rather than by the cessation of menstruation itself. Therefore, a woman who has undergone a hysterectomy but who retains her ovaries will experience normal menopausal symptoms as oocyte depletion leads to hypoestrogenism, even though cessation of menstruation occurred with surgery. In cases where we do hysterectomy but leave the ovaries behind the depletion of oocytes would occur earlier than expected and so woman will perceive menopausal changes earlier but not immediately after surgery.

Natural menopause occurs at or after 40 years of age and has no underlying pathologic cause.

**Induced menopause** may occur after:

- Chemotherapy,
- Pelvic radiation, or,
- Bilateral oophorectomy.
- Menopause is considered premature when it occurs before 40 years of age but is otherwise normal and not surgical
- **The climacteric**, a term now used infrequently, refers to the time of waning ovarian function associated with menstrual irregularity and vasomotor symptoms.
- **Perimenopause** is the time between the onset of the climacteric and the year after the last menses.
- **Premenopause** is the entire reproductive span before onset of the menopausal transition, and postmenopause is the span of life after menopause.

### The Menopausal Transition

Menopausal transition is replacing perimenopause and climacteric as the preferred term to describe the time of physiologic change around the cessation of ovarian function.

This is the stage which precedes menopause, has an average duration of 4 years, with a range of 0 to 10 years. The mean age at which menopause occurs in developed countries is 51 years and may be increasing. The standard deviation around this mean is about 2 years. Approximately 95 per cent of women experience menopause by 55 years of age.

### Postmenopause

*As Defined by WHO*

By WHO the term postmenopause is defined as dating from the final menstrual period, regardless whether the menopause was induced or spontaneous.

The postmenopause lasts about 10-15 years and is followed by the senescence from about 65 years of age to the end of life. This age limit is marked by the successive occurrence of the maximum rate of cardiovascular, orthopaedic and oncologic diseases. After this age, oestrogen substitution may be accompanied by higher vascular and oncologic risks.

### Early Postmenopause

This is the period within 2 years after menopause.

### Senescence

After the age of 60 years. Some use 65 years as the cut off age.

There is staging of reproductive aging by STRAW (The stages of Reproductive Aging Workshop) where relationship of final menstrual period and menstrual cycles with FSH levels was taken into account, and in this staging reproductive years, menopause transition and post menopause are divided into early and late.

### Another Menopause Staging was first Published by Dr. Behram Anklesaria in 1997 (Fig. 53.1)

#### Stage I

From the earliest perimenopausal symptom (usually vasomotor instability or menstrual irregularity) to menstrual cessation (menopause). The stage can last from 3 to 5 years.

#### Stage II

"Five years after menopause". This stage is further subdivided into stage IIA and Stage IIB.

Menopause			
<b>Stage I</b> Roughly 2 years before the menopause Early (Premenopausal) symptoms	<b>Stage II</b> <b>Stage IIA</b>	<b>Stage IIB</b> Upto 5 years after the menopause Intermediate (Postmenopausal) symptoms Atrophic changes	<b>Stage III</b> ? Life time Late (Postmenopausal) complications
<b>IA</b> Vasomotor instability		<b>IIB Late</b> Psychosomatic symptoms	<b>IIIA</b> Residual changes
<b>IB</b> Early psychosomatic symptoms			<b>IIIB</b> Ischemic heart
			<b>IIIC</b> Very late complications e.g. Alzheimer's disease
<b>Palliate !</b>	1 year	<b>Treat !</b>	<b>Prevent !</b>

Fig. 53.1: Stages of Menopause by Dr. Behram Anklesaria

**Stage IIA:** "From the cessation of menstruation upto 1 year" (that is upto confirmation at menopause by WHO definition). The main symptoms of menopause during this stage are vasomotor instability and urethral syndrome.

**Stage IIB:** From end of stage IIA upto four years. The common issues here are:

- a. Atrophic symptoms, vaginitis, dyspareunia
- b. Urinary symptoms
- c. Weight gain
- d. Skin and hair changes
- e. Genital prolapse
- f. Late psychological symptoms
- g. Sexual disorders.

**Stage III**

"From 5 years after menopause upto an indefinite period; probably life time".

These are divided into the following:

- IIIA - Residual atrophic symptoms
- IIIB - Stage of Ischemic Heart Disease and early osteoporosis.
- IIIC - Very late complications like cerebrovascular changes and Alzheimer's disease.

In USA in 2003 survey percentage of menopausal women is as under:

- At years 89 per cent
- At 40-50 years 6.9 per cent
- <40 years 0.5 per cent
- Surgical 4 per cent

In India mean age of menopause is 49.4 years and 130 million Indian women are expected to live beyond menopause into old age by 2015. In India 19 per cent of women age 40-41 have already reached menopause, and the incidence of menopause increases rapidly after the age 41. By age 48-49, two thirds of women are in menopause. So the number of women in menopause is increasing with increase in life expectancy and so is the increase in reported problems. Therefore quality of life of this population becomes a major issue and understanding of menopause is very important issue for all the clinicians as most of the time it is a multidisciplinary approach to the problems of menopause.

### Factors Influencing Age of Menopause

Several factors appear to influence the age at which women experience menopausal symptoms and the final menstrual period; for example,

- Menopause occurs approximately 1 year earlier in smokers and
- Occurs earlier in nulliparous women.
- Menopause may also occur earlier in women who have had ovarian cystectomies or unilateral oophorectomies.
- Ovarian drilling done for PCOD
- When patient get pelvic radiotherapy or chemotherapy
- In Indian women it is earlier so genetics or racial factors may also be contributing towards age of menopause.

### Physiology of Menopause

In females throughout reproductive life ovarian follicular depletion is occurring by atresia. In fact this process starts earlier in foetal life itself. At 5 months of foetal age, the ovaries contain their peak number of primordial follicles, totaling approximately two million. At birth, girls have one million primordial follicles, approximately 25 per cent of which remain at puberty. During the reproductive years, many follicles will begin to develop during each ovulatory cycle; except dominant follicle all other follicles become atretic. So only estimated 500-1,000 follicles remain in the ovaries of a woman 51 years of age. Some follicles persist for a few years after the menopause but these are poorly responsive. This progressive loss of follicles that goes on with aging is characteristic of all mammals studied to date; however what are the controlling factors for this process have not been well defined.

Beginning as early as 10 to 15 years before menopause, there is shortening of the follicular phase of the cycle and so the length of the menstrual cycle starts decreasing. This decrease in cycle length continues until the onset of the menopausal transition, when both the average cycle length and the standard deviation of cycle length begin to increase as follicles are depleted and ovulation occurs less frequently. Insufficient follicular development results in inadequate oestrogen production. With little oestrogen available to stimulate the endometrium, amenorrhoea results (Fig. 53.2).

There is good evidence that the timing of natural menopause is genetically programmed, but the specific genes involved are yet to be well defined. Common allelic variants of the oestrogen receptor gene (oestrogen receptor- [*ER-α*] and *ER-β*) contribute to the variability in the timing of menopause. In addition, all of the steroid

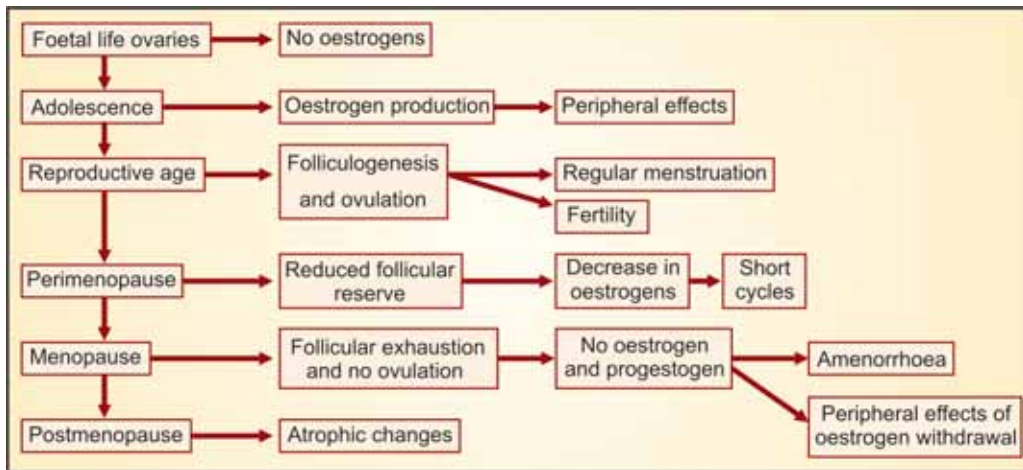


Fig. 53.2: Chronology of Age related oestrogen production

receptors, as well as the proteins and enzymes involved in steroid biosynthesis and metabolism, are known to be coded by polymorphic sites (genetic changes found in at least 1% of the population). Because of this variability there are different timings of menopausal symptoms and intensity and duration of symptoms are also variable.

### Hormonal Changes

A subtle rise in the concentration of follicle-stimulating hormone (FSH) is the earliest and most consistent clinically measurable hormonal change noted in studies of reproductive aging. An FSH level measured during the early follicular stage of the menstrual cycle that is greater than two standard deviations above the mean level in women of reproductive age is a marker of impending menopausal transition.

In the premenopause ovarian granulosa cells under the influence of FSH are producing oestrogens but because of follicular atresia there is first fall of oestradiol and fall of Inhibin B and this leads to increase in level of FSH but there is further decrease in levels of oestradiol and it is oestrone that becomes main dominant hormone because of peripheral conversion of testosterone into oestrone.

A slow rise in FSH occurs first, followed by a rise in LH and a decline in oestradiol and oestrone. There are no abrupt changes in testosterone, but a gradual continuous decline occurs that begins before the menopausal transition and this is because of aging of adrenal cortex and testosterone from adrenal cortex is

decreased because of aging starting from third decade onwards. Ovaries continue to produce androgens and so at menopause there is not much fall of testosterone.

Luteinizing hormone (LH) levels remain normal initially, but it is also elevated as ovarian steroid secretion falls and gonadotropin-releasing hormone (GnRH) increases because of follicular atresia inhibin B levels are decreased and this causes early selective increase in FSH. Inhibin A and B, hormones that are involved in directing follicular development suppress pituitary FSH production. As anovulation predominates in perimenopause period FSH and LH remain chronically elevated (Fig. 53.3).

There is a 10-fold to 20-fold increase in the FSH level and a threefold to fivefold increase in the LH level, and oestradiol levels fall below 50 pg/ml.

Even in menopause ovarian theca cells are producing androstenedione and testosterone under influence of increased levels of LH, and they are the source of androgens in menopause and when we do oophrectomy in women there is sudden fall of androgens because of loss of this source of androgens. By aromatisation adipocytes produce oestrone from testosterone and so in menopause oestrone becomes dominant hormone. Hormonal synthesis by the adrenal gland remains fairly constant, undergoing changes associated with aging, not menopause per se. Because of aging of adrenal gland levels of androgens fall up to 50 per cent at 60 years of age as compared with women at 40 years of age and after age 70, levels of DHEA and DHEAS are 20 per cent or less.

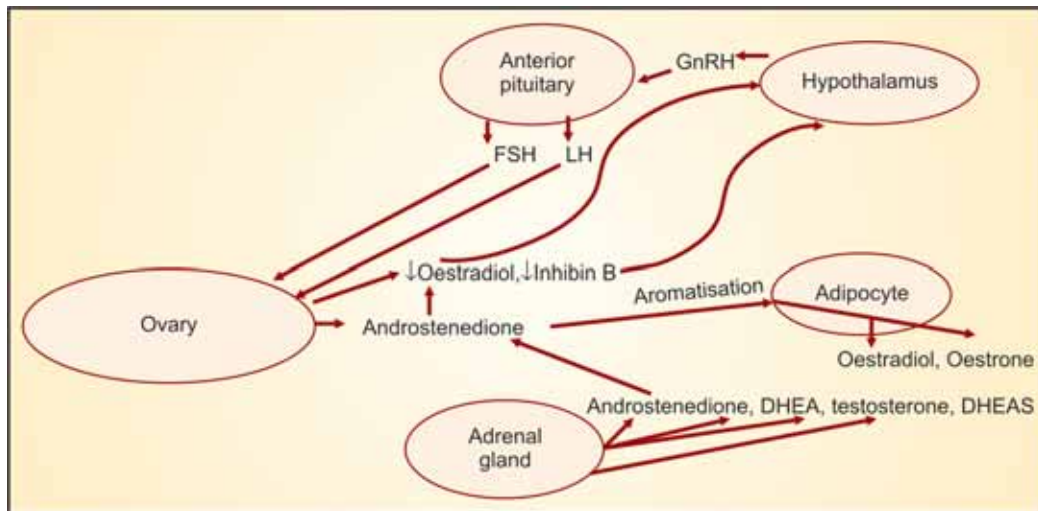


Fig. 53.3: Cycle of Hormonal changes in menopause

### Final Hormonal Changes with Established Menopause

Compared with the typical hormonal changes in the early follicular phase of ovulatory women, in postmenopausal women, the most significant findings are the marked reductions in E2 and oestrone (E1) levels. The serum E2 level is lower than the serum E1 level. Serum E1 is produced primarily by peripheral aromatisation of androgens, which are not as dramatically affected by menopause. Postmenopausal levels of E2 average 15 pg/mL and range from 10-25 pg/mL. In oophorectomised women, levels are usually 10 pg/mL or lower. Serum E1 values average 30 pg/mL but may be higher in obese women, because aromatisation increases because of increased mass of adipose tissue. Oestrone sulfate (E1S), an oestrogen conjugate that serves as a stable circulating reservoir of oestrogen, has the highest levels of any oestrogen. In premenopausal women, E1S is usually above 1000 pg/mL; in postmenopausal women, levels average 350 pg/mL.

- Androgens produced by adrenals are androstenedione, DHEAS (Dehydroepiandrosterone sulphate), DHEA (Dehydroepiandrosterone), testosterone and DHT. However, DHEA, DHEAS, and androstenedione are considered proandrogens because they must be converted to testosterone in order to be effective. Androgen biosynthesis occurs in the ovary and the adrenal under stimulation by LH (luteinising hormone) and ACTH (adrenocor-

ticotropic hormone), respectively, along with intraglandular paracrine and autocrine regulatory mechanisms. Starting from the third decade of life, independent of menopausal transition, circulating  $\Delta$ -5 androgen levels fall linearly with age. After menopause thecal cell of ovary under influence of LH go on producing androgen, but after surgical menopause or oophorectomy there is sudden fall of androgens to about 50 per cent of preoperative values whether hysterectomy with bilateral salpingo-oophorectomy was done in perimenopause or in menopause.

Women undergoing the transition from pre- to postmenopause have some changes in androgens, with the menopausal transition. Specifically, both androstenedione and testosterone decline 3 years before menopause, and some fluctuations in the testosterone levels occur after menopause. However, immediately after menopause, it is decline in androstenedione which is greater than that of testosterone; that is, in early postmenopause, testosterone levels may be indistinguishable from those in premenopausal women. During postmenopause, virtually 100 per cent of active sex steroids derive from the peripheral conversion of precursors, mainly DHEA and DHEAS, to oestrogens and androgens. Ultimately, several years after the menopause, the levels of androstenedione and testosterone are significantly lower than levels measured in premenopausal women.

## Problems Associated with Menopause

Two oestrogen receptors exist: ER-alpha and ER-beta. Although the DNA-binding domains of the 2 receptors are almost identical (about 97% homology), the ligand-binding domains are different and have only 60 per cent homology. Various oestrogens have different affinities for ER-alpha and ER-beta, which, in turn, have different tissue distributions in the body. For example, preliminary evidence suggests that in certain regions of the brain (e.g., frontal cortex), ER-beta predominates over ER-alpha. In the cerebellum, only ER-beta is expressed.

Because ERs are abundant throughout the body, the menopausal decline of oestrogen potentially affects virtually all organ systems.

Most of the problems associated with menopause are mainly because of deficiency of estrogens but some problems may be because of deficiency of other hormones also as testosterone.

So far 35 symptoms have been associated with menopause:

1. Hot flashes, flushes, night sweats and/or cold flashes, clammy feeling
2. Bouts of rapid heart beat
3. Irritability, mood swings
4. Sudden tears
5. Trouble sleeping through the night (with or without night sweats)
6. Irregular periods; shorter, lighter periods; heavier periods, flooding; phantom periods, shorter cycles, longer cycles
7. Loss of libido
8. Dry vagina
9. Crashing fatigue
10. Anxiety, feeling ill at ease
11. Feelings of dread, apprehension, doom
12. Difficulty concentrating, disorientation, mental confusion
13. Disturbing memory lapses
14. Incontinence, especially upon sneezing, laughing; urge incontinence
15. Itchy, crawly skin
16. Aching, sore joints, muscles and tendons
17. Increased tension in muscles
18. Breast tenderness
19. Headache change: increase or decrease
20. Gastrointestinal distress, indigestion, flatulence, gas pain, nausea
21. Sudden bouts of bloat
22. Depression
23. Exacerbation of existing conditions
24. Increase in allergies
25. Weight gain
26. Hair loss or thinning, head, pubic, or whole body; increase in facial hair
27. Dizziness, light-headedness, episodes of loss of balance
28. Changes in body odor
29. Electric shock sensation under the skin and in the head
30. Tingling in the extremities
31. Gum problems, increased bleeding
32. Burning tongue, burning roof of mouth, bad taste in mouth, change in breath odor
33. Osteoporosis
34. Changes in fingernails: softer, crack or break easier
35. Tinnitus: ringing in ears, bells, 'whooshing' buzzing etc.

## EFFECT OF OESTROGEN DEFICIENCY

### Brain and Central Nervous System

Oestrogen receptors are abundant in the brain. Oestrogen is known to have a role in many brain processes, and the absence of oestrogen can result in physiologic and symptomatic changes. Oestrogen is important for cerebral blood flow, cerebral glucose administration, synaptic activity, neuronal growth, the survival of cholinergic neurons, as well as such complex functions as cognition.

### Hot Flashes

Hot flashes are an early and acute symptom of oestrogen deficiency. They often begin in the perimenopause when oestrogen levels characteristically fluctuate widely. It is the rapid fall in oestrogen level that precipitates the symptoms. Hot flashes typically last from 0.5 to 5 years after natural menopause but may persist as long as 15 years. They tend to last longer and be more severe with surgically induced menopause.

Night sweats can be more upsetting than daytime flushes because they disrupt sleep. Some women find that as a result of hot flashes they suffer from

- Insomnia, which leads to
- Irritability,

- Tiredness and
- Forgetfulness.

However, psychological changes attributable to chronic sleep disturbance may be more than side effects of hot flushes — a direct effect of changing hormonal status may also play a role.

But these symptoms are not universally experienced and high prevalence in western societies (58 to 93 per cent in 1st two menopausal years) is not found in other societies. elsewhere. Japanese women report very few hot flushes and Mayan women at Mexico do not report any symptoms of menopause. Among Indians too, the symptoms are not very common. Thus, the prevalence of vasomotor symptoms varies widely across populations and is strongly influenced by culture and ethnicity.

### Physiology of Hot Flushes

Although the proximate cause of flushes remains illusive, the episodes result from a hypothalamic response (probably mediated by catecholamines) induced by a change in oestrogen status. The flush has been well characterised physiologically: heat dissipation occurs through an increase in peripheral temperature (e.g., in the fingers and toes); a decrease in skin resistance, associated with diaphoresis; and a reduction in core body temperature). Heart rate and skin blood flow peak within approximately 3 minutes of hot flush onset, which leads to vasodilatation and decrease in internal temperature (0.1 degree to 0.9 degree C) leads to a feeling of chill. Skin temperature returns to normal usually within 30 minutes. No significant change in BP is associated with hot flushes.

There are hormonal correlates of flush activity, such as an increase in serum LH and plasma proopiomelanocortin peptides (adrenocorticotrophic hormone, beta-endorphin) at the time of the flush; however, these occurrences are thought to be epiphenomena that result as a consequence of the flush and are not related to its aetiology.

### Diagnostic or Metabolic Workup for Differential Diagnosis of Hot Flushes

- Levels of follicle stimulating hormone (FSH) indicate ovarian reserve. FSH values of >10 IU/L are indicative of declining ovarian function. FSH values >20 IU/L are diagnostic of ovarian failure in women

in the perimenopausal age group with hot flushes even in the absence of cessation of menstruation.

- Serum pooled prolactin levels are useful in differentiating hyperprolactinaemia from menopause. After 1-3 years of cessation of menstruation (menopause) LH levels reach to over 30 IU/L.
- Although, as mentioned, there are multiple different aetiologies for hot flushes apart from menopause, carcinoid syndrome is one that is essential to suspect and exclude given the underlying association with malignancy. This is associated with systemic symptoms and elevated levels of urinary 5-HIAA.

### Management

Counselling the woman is most important.

- *Pharmacological Preparations:* The gold standard of treatment for menopausal hot flushes is oestrogen therapy.

Hormone therapy either oestrogens alone (in hysterectomised women) or in combination with progestogen, in minimum dosage and for shortest period of time are prescribed, they can be either by oral route or transdermal route or transvaginal route or pellets of oestrogens. Other than oestrogen, no other therapy has been approved by FDA for the treatment of hot flushes. However, some women may be unsuitable for HRT due to contraindications; unwilling to take HRT; or unable to continue HRT due to intolerable side effects. Tibolone is another drug which is found to be effective in hot flushes.

The various non pharmacological options for managing hot flushes are as follows:

- *Lifestyle modifications:*
  - Adopting certain life-style measures can decrease the intensity and frequency of hot flushes. It is recommended that all women with hot flushes be counseled regarding these options and encouraged to use them.
  - Avoidance of triggering factors like stress, caffeine, alcohol, spicy foods, beverages
  - Avoid smoking
  - Reduction of stress - practice meditation, yoga, massage, paced breathing
  - Staying in a cold environment, avoiding warm places
  - Keeping cool and the ambient temperature low, drinking cold drinks, bathing in cool water, using

- fans, using cotton sheets, wearing appropriate breathable cotton clothing, dressing in layers
- Exercise – undertake aerobic and weight bearing exercises, exercise reduces hot flushes in 50 per cent of cases.
  - Weight loss
- *Placebo*: Placebo use may lead to 20-50 per cent reduction in hot flushes after 4 weeks of treatment. Combinations of above.
  - *Non-hormonal* medications includes the use of following drugs:
    - a. Antidepressants – venlafaxine (serotonin and norepinephrine reuptake inhibitors), paroxetine, fluoxetine
    - b. Propranolol
    - c. Gabapentin-A  $\gamma$ -aminobutyric acid (GABA) analogue used for seizure disorders as an anticonvulsant
    - d. Evening primrose oil
    - e. Verapride
    - f. Herbal remedies – black cohosh, red clover, Dong quai
    - g. Belladonna is not advised now in view of side effects.
    - h. Clonidine – $\alpha$  adrenergic agonist is commonly used as an antihypertensive
    - i. Cetrizine
    - j. Nutraceuticals like Vitamins – B complex, C, E
    - k. Dietary Phytoestrogens
  - *Behavioural interventions*
    - Paced respiration (slow deep abdominal breathing)
    - Relaxation training
    - Cognitive behavioural intervention and diversion techniques
    - Progressive muscle relaxation or biofeedback or applied relaxation
    - Hypnosis
    - Acupuncture
- Among the non-pharmacological therapeutic options, antidepressants **Venlafaxine, paroxetine, fluoxetine have better results.**

### Mood Changes and Cognitive Function

In general, oestrogen has a positive effect on mood and contributes to a sense of well-being.

Exercise like aerobic training, dance, meditation, yoga and swimming may also help in some cases.

The role of oestrogen deficiency in postmenopausal depression, declining cognitive function, dementia, and Alzheimer's disease is not clear and is an area of intensive debate and research

### Migraines

Oestrogens and progestins affect central serotonergic and opioid neurons. Alterations in the level and cycling of these hormones may cause a change in the prevalence or intensity of headaches. Because the orderly pattern of oestrogen and progesterone secretion is lost as menopause approaches, perimenopausal women with a history of menstrual migraines may experience an exacerbation.

### Vision

There is an increased incidence of some vision-threatening conditions in postmenopausal women. For example, idiopathic full-thickness macular degeneration predominantly affects women older than 60 years. There appears to be a hormonal component, because symptoms become more severe with menopause. Changes in hormonal status may thus affect the physiology of the eye.

There are gender and age differences in ER-alpha expression in the retina. ER-alpha was detected in the retina and retinal pigment of young female eyes but not in the eye tissues of postmenopausal women.

### Collagen

Oestrogen has a positive effect on **collagen, which is important for bone and skin. Both oestrogen and androgen receptors have been identified** in skin fibroblasts. The loss of collagen is more rapid in the first few years after menopause, and 30 per cent of skin collagen is lost within the first 5 years after menopause. The rate of collagen decrease is approximately 2 per cent per year for the first 10 years after menopause. This statistic, which is similar to that of bone loss after menopause, strongly suggests a link between skin thickness, bone loss, and the risk of osteoporosis. In addition, reductions in collagen support and atrophy of the vaginal and urethral mucosa have been associated

with a variety of symptoms, including uterine prolapse and urinary incontinence.

### Urogenital Atrophy

Oestrogen deficiency has deleterious effects on the urogenital system. It has been reported that as many as one third of women aged 50 years and older experience urogenital problems. Oestrogen deficiency results in a

- Thin and paler vaginal mucosa
- Loss of normal rugosities
- The moisture content is low
- The pH increases (usually pH > 5), and
- It may exhibit inflammation and small petechiae.
- Cytology reveals a loss in superficial cells and an increase of basal and parabasal cells.
- In reproductive-age women, the vaginal flora is dominated by lactobacilli. In postmenopausal women, the vagina is gradually repopulated with diverse flora, including pathogenic organisms commonly found in urinary tract infections (e.g., coliform bacteria), as a result of the reduced acidity. The decrease in lactobacilli, yeast, and bacterial vaginosis-associated bacteria also may explain the lower incidence of bacterial vaginosis and yeast vaginitis in postmenopausal women than in women of reproductive age (Fig. 53.4).
- The lower urinary tract and the genital tract in females have a common embryological origin. Oestrogen receptors have been reported in the trigone of the bladder and the proximal and distal urethra.



Fig. 53.4: Vaginal atrophy, loss of rugosities, pale epithelium

- Functional changes which have been noted include the following:
- Elderly women have lower flow rates,
- Higher bladder volume at the first sensation to void,
- Increasing urinary residue,
- Similarly, changes in collagen in the endopelvic fascia and periurethral tissue account for the hypermobility and reduced urethral closure pressure and may thus explain the prevalence of stress incontinence.

Dry and atrophied vaginal and urethral epithelium can cause

- Vaginal discomfort,
- Itching,
- Dyspareunia, and
- Recurrent vaginitis

### URINARY SYMPTOMS AT MENOPAUSE

Common symptoms which are encountered at menopause, postmenopausal age group and the elderly are:

1. Increased day time frequency and nocturia
2. Urgency with varying degrees of urge incontinence
3. Stress incontinence
4. Dysuria
5. Incomplete evaluation of varying degrees upto frank chronic retention with overflow incontinence.
6. Recurrent UTI and asymptomatic bacteriuria.
7. Enuresis.

### Recommendation

All women presenting with urinary symptom should be evaluated with a detailed history and the following tests: as appropriate to the individual

- Urine routine and culture
- Cytology (Where indicated)
- Ultrasonography
- Urodynamic
- Hormonal profile
- Bladder diary

### Treatment Includes

1. Antibiotics for UTI.
2. Local oestrogens or system oestrogen ± progesterone therapy.
3. Appropriate surgical intervention.
4. Bladder training.



### Weight Gain and Loss of Muscle Mass or Sarcopaenia

- The prevalence of obesity in adult women rises significantly each decade, until it begins tapering off late in life.
- About 20 per cent gain weight of about 4.5 kg in the three years surrounding menopause. While only 3 per cent lose that amount of weight.

### Changes in Fat Distribution

Although weight changes may be more strongly associated with aging than with menopause,

- Women who have undergone menopause may have higher levels of body fat and a more central fat distribution than age-matched controls.
- Women are losing more of lean muscle mass and gaining more of fat.

From a clinical standpoint, the effect of menopause on abdominal obesity is of major concern, since abdominal obesity has been shown to be an independent predictor of type 2 diabetes, dyslipidemia, hypertension, certain cancers, and cardiovascular disease.

### Causative Factors for These Changes

- The age-related decline in RMR and decreased physical activity, with or without increased caloric intake, could easily result in weight gain.
- Changes in resting metabolic rate (RMR) have been observed, which may be due in part to a decline in fat-free mass or sarcopaenia.
- Loss of ovarian function and loss of interleukin in the luteal phase of the menstrual cycle may also contribute to decreased RMR.
- Oestrogen has been found to influence eating behaviour and their loss causes weight gain in animals.

### Prevention of Weight Gain

Life style modifications are the mainstay of prevention and control.

Currently, the most effective behavioural approach for management of overweight and obesity is a combination that includes:

- Reduced caloric intake (typically 1,000 to 1,200 kcal/day for women)
- Dietary fat reduction (30% of calories)

- Increased physical activity (at least 30 min -45 min of moderate-intensity activity on most days of the week) when losing weight along with aerobic activity resistance and strength building exercises should also be started to counteract the loss of lean muscle mass.
- Behavioural guidance.

### BONE LOSS (OSTEOPOROSIS) AND FRACTURE RISK

In women, peak bone mass is achieved by the second decade and begins to decrease thereafter after 35 years of age.

In industrialised western countries, more than one third of women older than 65 years suffer from symptoms of osteopaenia/osteoporosis, a disorder characterised by low bone mass (Fig. 53.7).

### Risk Factor Assessment

The most important risk factors for osteoporosis related fractures are:

- Prior fracture(s) with trivial trauma as an adult, which strongly predicts the potential for future fractures and,
- Low bone mineral density (BMD) in patients with or without fracture
- Advancing age
- Family history of osteoporosis, fractures in first-degree relatives
- Loss of more than 1.5 inches height loss
- Vitamin D deficiency (very common in India)
- Low calcium intake (<300 mg per day)
- Tobacco use
- Alcohol intake more than 7 oz per week
- Weight loss and low body weight
- Any condition that increases the risk of falling
- Other secondary causes of bone loss (which may be present in up to 1/3rd of women)
- Activity level, and lifestyle
- Extremely important is the total amount of bone a woman has at the time of menopause.

### Definition

Postmenopausal osteoporosis is characterised by low bone mass and microarchitectural deterioration of bone tissue leading to enhanced bone fragility and increased fracture risk.

According to the World Health Organisation, osteoporosis is defined based on the following bone density levels:

- BMD is compared to two norms - healthy young adults (T-score) and age-matched (Z-score) (Fig. 53.5). A T-score within 1 SD (+1 or -1) of the young adult mean indicates normal bone density.
- A T-score of 1 to 2.5 SD below the young adult mean (-1 to -2.5 SD) indicates low bone mass.
- A T-score of 2.5 SD or more below the young adult mean ( $> -2.5$  SD) indicates the presence of osteoporosis.

Oestrogen deficiency is a dominant pathogenic factor in bone loss. This can be noted for the first time during perimenopause. From 1.5 years before menopause to 1.5 years after menopause, spine bone mineral density (BMD) decreases by 2.5 per cent per year, compared with a premenopausal loss rate of 0.13 per cent per year.

At menopause, an accelerated loss of bone occurs, which results in a 3 per cent reduction in bone mass per year for the first 5 years; thereafter, the rate of loss of bone ranges from 1-2 per cent per year. Dramatic changes in bone architecture accompany this loss in bone, greatly increasing the risk of fracture. Every standard deviation of reduction in bone mass results in a 1.5 to 2-fold or greater risk of fracture (Fig. 53.6).

### Role of Oestrogen in Osteoporosis

- Oestrogen action on bone is mediated by direct effects on bone through the oestrogen receptor and by effects

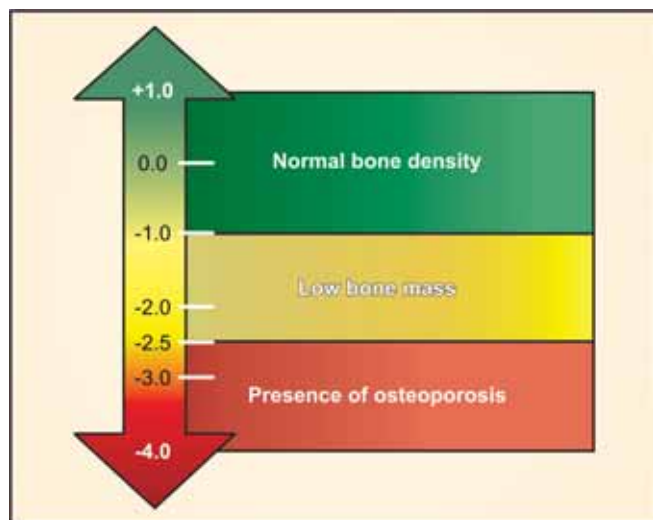


Fig. 53.5: T-score normal, osteopaenia and osteoporosis

on collagen. The accelerated decline in bone mass that occurs with oestrogen deficiency is mediated by a variety of mechanisms, but the primary event is increased resorption (osteoclastic activity), which becomes uncoupled from bone formation (osteoblastic activity).

- There are also indirect effects mediated by parathyroid hormone and cytokines, which oppose the resorptive effects.
- Osteoprotegerin (OPG), for example, a member of the TNF-receptor family, is a soluble protein that inhibits osteoclastic bone resorption. OPG is secreted by osteoblasts and binds to OPG ligand, a factor necessary for osteoclastogenesis. Serum levels of OPG appear to be significantly elevated in postmenopausal women with osteoporosis. In addition, oestrogen enhances OPG secretion by osteoblasts *in vitro*, suggesting that OPG may have an important role in the antiresorptive action of oestrogen on bone.
- In postmenopause, the positive effects of oestrogen on growth factors, calcitonin, vitamin D metabolism and calcium absorption are also diminished.

### Biochemical Markers of Bone Turnover

- Biochemical markers of bone turnover could reflect primarily formation (serum bone-specific alkaline phosphatase enzyme, serum osteocalcin), or resorption (urinary C- or N-telopeptides- collagen breakdown products). These biochemical markers are not useful in the diagnosis of postmenopausal

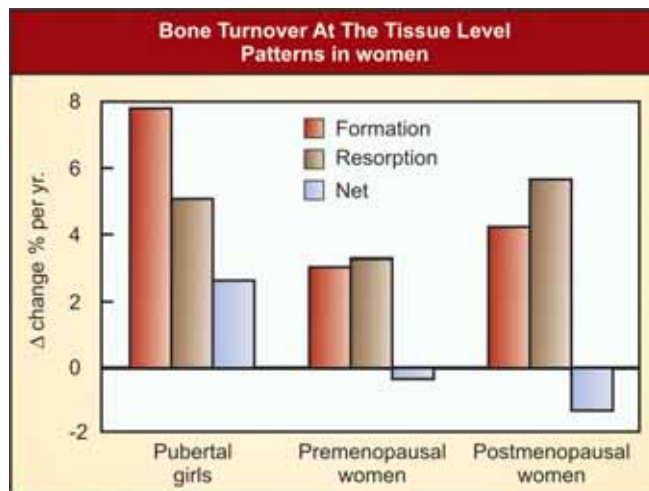


Fig. 53.6: Bone turnover from puberty to menopause

	2002	2010	2020
<b>Women</b>			
Osteoporosis	7,800,000	9,100,000	10,500,000
Low bone mass	21,800,000	26,000,000	30,400,000

**Fig. 53.7:** Projected prevalence of osteoporosis and/or low bone mass of the hip in U.S. women  $\geq 50$  years old

osteoporosis because the values in normal and osteoporosis show a substantial overlap. However, they may be useful in the following situations

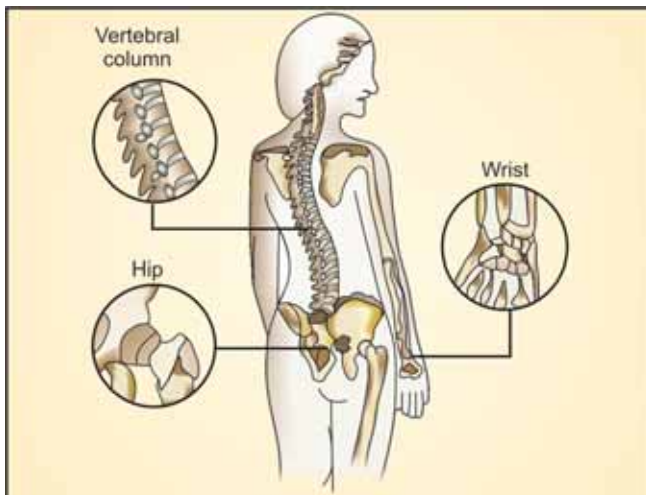
1. Assessing response to antiresorptive therapy.
2. Assessing compliance to medications.

Three main sites of increased risk of fracture in postmenopause women are (Fig. 53.8):

- Wrist
- Hip
- Spine and 30 per cent of spine fractures go unnoticed

### Spinal Complications of Osteoporosis

- Kyphosis
- Vertebral wedging
- Compression fractures.
- The most common fractures due to osteoporosis are vertebral fractures, and yet less than a third of all vertebral fractures are clinically diagnosed (Fig. 53.9).



**Fig. 53.8:** Sites of fracture

These complications lead to poor quality of life for these women and they have problems in walking and in carrying our routine activities of life.

### Back Exercises for Kyphosis

The thoracic kyphosis of oestrogen-deficient women has been found to be directly correlated with weakness of the back extensor muscles, and increasing the back extensor strength has been shown to decrease the kyphosis. In this instance, when the torso is carried flexed forward, the patient will need to retrain the extensor muscles of the spine with isotonic resistance exercises. This is most effective when done in an upright, weight bearing position. So from 35 years onwards all women should do resistance exercises to strengthen back muscles.

### PREVENTION AND MANAGEMENT OF OSTEOPOROSIS

A management strategy focused on lifestyle approaches may be all that is needed for women who are at low risk for osteoporotic fracture.

These life style modifications are:

- No smoking
- Calcium 1200-1500 mg/day
- Vit. D 400-600 IU/day
- But main stay is exercise and these have to be weight bearing and resistance exercises, especially for back



**Fig. 53.9:** Kyphosis in menopause



Fig. 53.10: Wide grip pulley press for upper back muscles

muscles to prevent kyphosis, (Fig. 53.10) wrist muscles, to prevent fractures of wrist, to strengthen thigh and buttock muscles to prevent fractures of hip bone. Quadriceps muscles weakness causes buckling of knees in old women so these muscles have to be strengthened. These exercises and proper calcium and nutrition should be started at adolescent level itself so that they don't have a negative BMD at midlife. Exercise specially weight bearing and resistance exercise have no age bar and can be started at any age even 80-90 years and they do increase functional independence and increase in strength and increase in bone density.

### Recommendations for Pharmacological Treatment

- All postmenopausal women with total hip or spine T scores worse than -2.5.
  - All postmenopausal women with total hip or spine T scores from -2.0 to -2.5 and at least one additional risk factor for fracture.
  - All postmenopausal women with an osteoporotic, vertebral fracture (no bone mineral density is needed).
    - *In premature menopause:* HT is recommended for prevention of osteoporosis till the time of her natural menopause and then it can be substituted by other pharmacological agents along with life style modifications and exercise.
- Several other agents are as effective as hormone therapy in preventing fracture due to osteoporosis:

- *Bisphosphonates:* Alendronate, risedronate, and ibandronate are commonly used for both prevention and treatment of osteoporosis. For prevention alendronate is available as a daily tablet of 5 mg and a weekly tablet of 35 mg. For treatment of postmenopausal osteoporosis the doses available are 10 mg tablets daily and 70 mg tablets weekly. For maximal GI absorption and to reduce the incidence of oesophageal irritation, alendronate must be taken in the morning on an empty stomach (1/2 hour before breakfast) with about 240 ml of plain water and the patient must remain upright for 1/2 hour after ingestion.
- Bisphosphonates in combination with oestrogen are more effective than either agent alone.
- *Selective oestrogen receptor modulators (SERMs):* SERMs (e.g., raloxifene) are indicated for the prevention and **treatment** of osteoporosis. They are not indicated for the **treatment** of menopausal symptoms and may even aggravate hot flashes in some women. They also do not help vaginal atrophy. As with oestrogen, a past history of venous thrombosis is a contraindication to their use. Current venous thrombosis is an absolute contraindication. They have a favourable effect on lipid profile and are cardioprotective. Available as 60 mg tab/day for prevention as well as treatment.
- *Calcitonin:* The nasal spray used for osteoporosis **treatment** that inhibits bone resorption and reduces fracture rates. Nasal irritation and cost limit its use. **Calcitonin** is available as a subcutaneous injection (about 100 IU per day) and as a nasal spray (about 200 IU per day) for treatment of postmenopausal osteoporosis
- *Parathyroid hormone (PTH e.g., teriparatide):* Daily subcutaneous injections are used for osteoporosis **treatment**. PTH is Food and Drug Administration (FDA) approved but carries a black box warning about possible risk for osteosarcoma based on rat studies.
- *Tibolone* is a synthetic steroid with oestrogenic, progestational and androgenic properties. It is metabolised by local tissue enzymes and therefore provides a unique "tissue specific approach" to menopause. It treats climacteric symptoms and does not increase mammographic breast densities (although data on breast cancer occurrence are not yet available). Tibolone seems to exert osteoprotective

effects similar to oestrogen, as judged by bone density and bone markers, but data on fracture prevention are awaited. The recommended dose is 2.5 mg daily. It increases libido, reduces hot flushes and so can be prescribed for that effect along with to prevent osteoporosis.

- *Osteoprotegerin*: This is a new drug and it is a naturally occurring protein and is a negative regulator of osteoclast formation that has shown promise as a potential treatment for osteoporosis.
- Zoledronic acid is new drug approved by FDA. A single intravenous infusion of Zoledronic acid 5mg over 15 min period once in a year decreases bone turnover and improves bone density and is effective in reducing hip, vertebral and other fractures.

### Cardiovascular Effects

The degree to which oestrogen deficiency increases the risk of cardiovascular disease (CVD) in women has not been definitively established and is a subject of intense debate and research.

Various studies have found increased incidence of CAD in menopausal women. Globally, it is also the leading cause of morbidity and mortality in women (54% in women Vs 43% in men).

Although, the death rate has fallen in men, it has increased in women because of the rising prevalence of hypertension, diabetes mellitus, sedentary habits, obesity and less decline in smoking.

- The most prevalent finding is that total cholesterol rises at an accelerated rate after menopause.
- This increase in total cholesterol results from increases in levels of low-density lipoprotein cholesterol (LDL-C),
- With the more dense forms predominating, and increases in very-low-density lipoprotein (VLDL) and lipoprotein a (LP(a)).
- The oxidation of LDL-C is also enhanced. High-density lipoprotein cholesterol (HDL-C) levels may decrease over time, but these changes are small and insignificant relative to the increases in LDL-C.
- Coagulation balance is not altered significantly with menopause because a counterbalance of changes occurs; some procoagulation factors increase (factor VII, fibrinogen), but so do certain fibrinolytic factors such as antithrombin III and plasminogen.
- Blood flow in all vascular beds decreases after menopause;

- Prostacyclin production decreases
- Endothelium levels increase
- Vasomotor responses to acetylcholine challenges are constrictive.
- Further, circulating plasma levels of nitric oxide increase
- Levels of angiotensin-converting enzyme decrease.
- Oestrogen and progesterone receptors have been found in vascular tissues, including coronary arteries. Overall, the direct vascular effects that occur after menopause are considered as important as, or more important than, the changes in lipid and lipoproteins in terms of CVD risk.

The WHI study showed some possible initial adverse cardiovascular effects, perhaps due to the dose of oestrogen being too high, but was suggestive of an eventful benefit. The benefit appeared to be greater in those women on oestrogen alone than in those on combined HRT, suggesting a possible adverse effect of MPA. Age of patient when oestrogen is started is important. If oestrogen is started earlier then cardio-protective effect is seen but at present hormone therapy is not indicated for prevention of CVD.

Randomised clinical trials have shown no benefit and some trials have suggested an increased rise of CHD during the first year after randomisation by HT (hormone therapy).

### Present Recommendations

Specific recommendations from several sources currently include the following:

- Identify and treat all CHD risk factors.
- Do not initiate HT for the prevention of CHD.
- Do not initiate HT in patients with known CHD.
- If CHD develops while on HT, consider other alternatives.

For prevention and to increase cardiorespiratory endurance 30 min/day of moderate aerobic activity is recommended like walking at a brisk pace, or swimming, cycling, yoga, taichi, lawn mowing or any other activity which causes repetitive movement of large muscles, along with proper diet.

### MENSTRUAL PROBLEMS

The perimenopausal period begins 2-5 years before the final menstrual period and lasts for 1 year thereafter. It is complex and unpredictable and DUB is one such

complexity. Contrary to popular belief, *oestradiol levels do not gradually wane in the years before menopause but remain slightly elevated until 6 months to 1 year before follicular growth and development cease.*

The greatest concern about DUB is relative oestrogen excess with endometrial hyperplasia and neoplasia although the usual finding is a non-neoplastic tissue with oestrogenic effects unopposed by progesterone. The menstrual cycle becomes irregular and unpredictable with both short and long follicular phases, defective ovulation and anovulation and highly erratic cycles. This pattern of irregularity should be distinguished from regular menstrual cycles interspersed with intermenstrual bleeding. Intermenstrual bleeding is associated with genital tract pathology and the gynaecologist should not overlook this. Anovulatory menorrhagia is frequent in this period but age-related and pathology-related changes in the uterus and ovaries may also be responsible. Experience and sensitivity is required to distinguish 'normal' perimenstrual patterns from pelvic pathology.

Similarly serious pathology may be present in 10-20 per cent of women with postmenopausal bleeding and it should be diagnosed and treated accordingly

- The endometrium is normal in 50 per cent,
- Atrophic in 20 per cent,
- Endometrial hyperplasia in seen in 15 per cent,
- Polyps in 3 per cent, endometrial cancer in 2 per cent.
- In India cervical malignancies, genital tuberculosis (cervix and endometrium), genital prolapse with decubitus ulcers are common causes of postmenopausal bleeding.
- 10 per cent of women with benign findings at initial evaluation will subsequently develop pathology in 2 years. Persistence of abnormal bleeding requires re-evaluation
- Approach for patients of perimenopausal and postmenopausal bleeding.

#### 1. History and Examination

- Careful history with menstrual pattern over the past 2-3 years is essential. A complete physical examination including breast must be done. Local examination of vulva, urethra for caruncles and anal region for fissures/piles to rule out other causes of bleeding. A Pap smear should be taken before pelvic examination At pelvic examination vagina and cervix must be thoroughly inspected for polyps, growths, ectropion etc. Finally a

bimanual pelvic examination is done and uterine and adnexal pathology assessed.

#### 2. Transvaginal sonography

- TVS is the next step and endometrial thickness, fibroids, adenomyosis, ovarian pathology evaluated. In a postmenopausal women endometrial thickness > than 4mm mandates endometrial biopsy.

#### 3. Endometrial Sampling

- An outpatient or office biopsy with plastic endometrial suction device using a 3-4 mm cannula is now recommended. No traditional D & C as first step.

#### 4. Colposcopy, cervical biopsy, fractional curettage and hysteroscopy.

- Additional procedures would be colposcopy, cervical biopsy and endocervical curettage for abnormal cytology or obvious lesions. Hysteroscopy and saline infusion sonography may be done in problematic cases with persistent bleeding to rule out polyps, any focal lesions or submucous fibroids.

#### • Management

#### • Perimenopausal DUB

- In the absence of organic disease management will depend on age of patient and endometrial histopathology. In women with a proliferative endometrium or simple hyperplasia oral progestins for 12 days of the month for 3-4 cycles is given. Hyperplasia with atypia does not respond to progestins. Progestin therapy reverses hyperplasia in majority of patients and is continued till withdrawal bleeding ceases. This reliably indicates oestrogen deficiency and oestrogen can be added or the combined oestrogen-progestin HRT started.

- If *contraception* is required a low dose pill will provide contraception, prophylaxis against irregular, heavy anovulatory bleeding and neoplasia, regularise cycles and relieve menopausal symptoms.

#### • Postmenopausal Bleeding

- Any organic pathology appropriate management
- Staging laparotomy for endometrial cancer
- Radical Wertheim's in invasive cancer cervix.
- Total abdominal hysterectomy with bilateral salpingo-oophorectomy in fibroids, adenomyosis etc and hormone therapy thereafter if women symptomatic after that.

### Management of Bleeding on Postmenopausal Hormone Therapy

- *Counselling* prior to initiating HRT is beneficial. With sequential HRT regular withdrawal bleed is seen in 80-90 per cent of patients. In continuous combined regime irregular breakthrough bleeding is common in the first 6 months but majority achieve amenorrhoea by the end of 1 year. Persistence of breakthrough bleeding is a management problem. Increasing the oestrogen or progestin dosage, education and patient support will help.
- Persistent bleeding can be re-evaluated by TVS and endometrial sampling and hysteroscopy if required. LNG- IUD, endometrial ablation or switching over to a more predictable sequential regime are other strategies.

### CANCER SCREENING IN MENOPAUSE

Leading cancers in women are:

- Breast cancer
- Cervical cancer
- Endometrial cancer.

### Recommendations for Screening for Breast Cancer

Early diagnosis of breast cancer is important. The 5-year survival rate depends on the stage at the time of diagnosis and ranges from 100 per cent for stage 0 to 16 per cent for stage IV. Other concomitant medical conditions also influence the survival rate.

- All women should be told at age 20 about the benefits and limitations of BSE. Breast self-exams should be supplemented with a clinical breast exam by a health professional every three years until age 40. After age 40, women should have a clinical breast exam and a mammogram every year.
- In some instances, physicians may recommend beginning screening mammography before age 40 as in instances of the woman having a strong family history of breast cancer or a lifetime oestrogen/HRT exposure such as nulliparity, older age at first birth, early menarche, late menopause or obesity.

### Management of Menopause

This is a physiological phenomenon and most of the women just breeze through menopause without having any initial problems but there can be problems later on,

which might influence her quality of life or some other medical problems can be diagnosed and treated effectively.

So when women come to us in menopausal transition we have to assess her for the high risk factor which would influence her quality of life later on and these include following:

1. Assess her weight and height and calculate her BMI which should be between 19-23 for the Asians and 20-25 for others.
2. If she is over-weight advise her regarding lifestyle modification like weight bearing exercises, regular walk and proper diet.
3. Take family H/O osteoporosis or fragility fractures or other risk factors for osteoporosis.
4. H/O Diabetes, hypertension
5. H/O previous fracture
6. H/O any drug intake
7. Family or Pt H/O CHD
8. Any H/O breast cancer in the family
9. Do her PAP smear if already not done and then every year till the age of 50 years
10. Do trans vaginal U/S if not already done or if dysfunctional bleeding
11. There is no need to do FSH or hormonal levels for diagnosis of menopause.
12. Advise mammography and BSE (breast self examination) once in month
13. Clinical breast examination (CBE) once in a year
14. Mammography 1-2 years after 40 years and every year after the age of 50 years.

### CREATING AWARENESS

The first step is creating an awareness in the women and in the society on the whole of the prevalence of problems and their prevention. So we have to create awareness about the vasomotor symptoms, about sarcopaenia, loss of bone mass, incidence of various cancers, screening procedures for them and guidelines about when they should have those. We should have regular menopause clinics.

### Life Style Modifications

- Avoid smoking
- Avoid alcohol
- Calcium 1200-1500 mg/day preferably from dietary sources

- Vitamin D 600 IU/day
- Exercise specially aerobic for cardiorespiratory and general fitness and weight bearing and resistance training for sarcopaenia and loss of BMD.

### Prescription of Exercise

Prescription of exercise should be given to all the women to prevent osteoporosis, sarcopaenia, for weight loss, for mood elevation, for less sleep disturbance. By exercising regularly flexibility and range of movement of joints is increased and added advantage of prevention of metabolic diseases like diabetes, hypertension, and CVD and over all health benefits are also there. Resistance and weight bearing exercises under the care of a trainer initially and then by integrating into lifestyle modifications would go in a long way to prevent osteoporosis and sarcopaenia (Fig. 53.11).

Exercise can be:

- Aerobic exercises like walking and dancing cycling, tread mill every day for cardiorespiratory benefits.
- Balance training like Tai Chi
- Flexibility and endurance like yoga
- Strength training and resistance training 2-3 times a week.
- Meditation like yoga.

### Informed Consent for Hormone Therapy

This is an era of informed choice by the patient. Patients deserve to know the facts and need help in dealing with any new state-of-the-art therapy and the uncertainty



Fig. 53.11: Global recommendations: Physical activity in middle-aged and older adults (50+ years of age)

associated with it. The clinician's role is to provide the education necessary for the patient to make the proper choices. Hence it is very necessary to assess the state of knowledge regarding the risk of breast cancer and HRT or HT for symptomatic relief of vasomotor or urinary or vaginal symptoms. We have to educate the women.

Before initiating therapy, women should undergo a complete health evaluation, including a comprehensive history, physical examination, and mammography. Other specific examinations, such as bone densitometry, should be considered on an individual basis. Oral health should also be seen, though incidence of osteonecrosis of jaw is rare.

Women should be informed about the various side effect of hormone therapy in the light of various studies like WHI, HERS, Million Women Study by taking HRT for a long time i.e. more than five years may lead to more incidence of breast cancer, CHD and DVT and stroke.

### Advantages of Hormone Therapy

Women must also be informed about the benefits of hormone therapy. Documented benefits of hormone therapy not directly related to menopausal symptoms include the following:

- Significant reductions in hip, vertebral, and total fractures with CEE/MPA
- Significant increases in spine and hip BMD with CEE/MPA
- Decreases in biochemical markers of bone turnover that correlate with increases in BMD
- Aids in the prevention of osteoporosis
- Reductions in the risk of colorectal cancer.

### VARIOUS TYPES OF HORMONAL AND NON-HORMONAL PHARMACOLOGICAL AGENTS AVAILABLE

#### Natural Oestrogens

Numerous natural oestrogen preparations are available, the principle products available being estradiol, estrone and oestriol in that order of potency

- Oestradiol is most physiological oestrogen since it is the predominant circulating oestrogen in the premenopausal reproductive women.
- Oestrone is less potent than oestradiol. Both *oestradiol* and *oestrone* have been demonstrated to be cardioprotective and osteoprotective



- *Oestriol* is a less potent natural oestrogen that has not yet been shown to be cardioprotective and osteoprotective, but has a good local action on genitourinary structures and also controls vasomotor symptoms.

### Semisynthetic Oestrogens

Because native steroids are relatively water insoluble, modifications of oestrogens for oral administration and gastrointestinal absorption includes conjugated oestrogens (oestrone sulphate, oestradiol valerate and conjugated equine oestrogen), micronisation (micronised oestradiol).

*Oestradiol valerate*: It is a natural human source of oestrogen which is chemically synthesised, provides rapid relief from climacteric symptoms prevents postmenopausal osteoporosis, and cardiovascular risks.

Bioavailability is good. Only 3 per cent is sufficient to exert effect on target organ.

*Micronisation* of oestradiol results in good levels of systemic oestrogens, although it is rapidly metabolised to oestrone and conjugated to oestrone -3-glucuronide in the liver.

### Synthetic Oestrogens

*Ethinyl oestradiol, quinestrol, and diethyl stilboestrol*, although used in contraceptives and other indications are not used in HRT because of their increased potency and extended half life. A regimen of the method of hormone administration is given in table 53.1.

**Table 53.1: Method of hormone administration**

Regimen	Oestrogen	Progestogen
Cyclic sequential	1st to 25th day	13th to 25th day /mth
Continuous sequential	Everyday	1st to 14thday /mth or 13th to 25th /mth
Continuous	Everyday	Everyday
Seasonal	Everyday	Last 14 days/every 3rd month

- Oral and transdermal oestradiol have provided similar benefits in clinical studies. Oral and non-oral hormone therapy regimens appear to have an equal positive impact on relieving symptoms of oestrogen loss, such as hot flashes, vulvovaginal atrophy, and loss of BMD.

- Combination of CEE 0.625 mg (conjugated equine oestrogen) with MPA 2.5 mg is as effective as CEE 0.3 mg/MPA 1.5 mg.
- Now combined patches of oestrogen and progestogen are available for women with intact uterus and there is no need to supplement oral progestogens. A combined transdermal patch containing norethisterone acetate 0.25 mg/day and 17 $\beta$  oestradiol 50 microgram/day is available. Transdermal HRT has favourable effect on total HDL cholesterol and triglycerides and no potentially adverse effect on glucose and insulin levels, in contrast to oral therapy. Efficacy of low dose of oestrogens has been studied.

Some new preparations are also available in the market with oestradiol as estrogen and this has also been found to be effective in dosage from 2 mg to as low as 0.5 mg/day.

If patient is hysterectomised then no need to add progestogen. But if patient has intact uterus, then progestogens are to be added. Progestogens are added for endometrial protection only.

Disadvantage of oral route are:

- Increased VTE risk
- Adverse lipid changes
- Hepatic side effects
- Gastrointestinal irritation
- Peaks and troughs in plasma levels are not stable.

### Hormone Delivery System

Additional investigations are required to clarify differences between hormone delivery systems.

- Because transdermal oestrogen bypasses first-pass metabolism in the liver,
- The transdermal delivery system makes it possible to achieve therapeutic concentrations in a steadier, smoother manner.
- Transdermal delivery also facilitates the use of lower doses than are required with oral delivery, with the benefit of reducing the potential for adverse effects.
- In cases where we want to by pass liver we can use transdermal delivery system.
- Transdermal delivery system is available as patches, as gels, creams and now available as spray also.
- It is available as estradiol and other advantages of transdermal spray are that it does not cause irritation which is there with transdermal patch.

- Intranasal estradiol preparations are also available and patient satisfaction is there.
- Pellets of oestrogen are also available but the only negative point is that it requires office visit every 3-6 months. Some times some soreness at implantation site is seen.

### Transvaginal Route

Drugs available as:

- Vaginal creams – Creams for local benefits are available, their absorption is limited and mainly used for local effects.
- Oestradiol ring releases 8 mg. oestradiol/24 h. at a constant rate. The ring is easy to insert and remove as it is soft and flexible. Each ring is to be used continuously for 90 days and is well tolerated giving significant relief from vaginal dryness, itching, dyspareunia and dysuria
- Vaginal tablets of oestradiol are also available.

At the doses recommended in labelling, all of the low-dose vaginal oestrogen products approved in the United States for treatment of vaginal atrophy are equally effective. The choice of treatment should therefore be individualised based on clinical experience and patient preference.

- Oestrogen cream is usually applied at a dose of 2 to 4 g/day for 2 weeks, at which point the dose should be lowered to the minimum necessary to improve symptoms.
- The sustained-release oestradiol ring is replaced every 90 days.
- The oestradiol tablet is usually inserted into the posterior vaginal vault once daily for 2 weeks, and the dose is then decreased to twice weekly.

Local oestrogen therapy is effective for symptoms of vaginal atrophy, although it is not effective for the management of vasomotor symptoms and cannot reduce the risk for osteoporosis.

Vaginal oestrogen therapy reduces vaginal pH by restoring lactobacilli.

Vaginal oestrogen may also treat vaginal atrophy caused by treatment with gonadotropin-releasing agonists and antagonists, aromatase inhibitors, and selective oestrogen receptor modulators. Local oestrogen therapy should be considered immediately following pelvic irradiation to stimulate epithelial regeneration.

When low-dose oestrogen is administered locally for vaginal atrophy, progestogen is generally not indicated. Data are insufficient to recommend annual endometrial surveillance in asymptomatic women using vaginal oestrogen therapy.

Vaginal oestrogen therapy should be continued as long as women continue to have distressing symptoms. Management of vaginal atrophy is similar for the group of women without a cancer history and for women treated for non-hormone-dependent cancer. However, for women with a history of hormone-dependent cancer, management recommendations are individualised and vary based on each woman's preference in consultation with her oncologist.

Overall, subjective improvement occurs in 80 to 90 per cent of women treated with local vaginal oestrogen.

### USE OF PROGESTERONE FOR HRT

Progesterone generation by the ovaries grinds to a stop at menopause. Hence the need to replace progesterone with oestrogen. *Currently, progestones are viewed as endometrial protective agents.* They are also used as progesterones only pills in perimenopause and control DUB in anovular cycles. However, in hysterectomized patients, they are often not prescribed. The main reasons are patient's intolerance to them, and the fear of their adverse effects on lipid profile and the breast. With the advent of natural progesterones and newer drug delivery systems we are able to bypass the first pass effect on the liver and we may have to reconsider the incidence of adverse effects and intolerance. We propose here a novel scoring system to help the gynaecologist tailor the HRT to the individual woman's need.

The currently available compounds are:

Progesterone analogues	Dydrogestone
	Hydroxyprogesterone
	Medroxyprogesterone acetate
Testosterone analogues	Norethisterone
	Norgestrel
	Levonorgestrel IUD
Newer synthetic progesterones	Desogestrel
	Norgestimate
	Gestodene
Halogenated progesterone	Cyproterone acetate
Antimineralocorticoid	Drospirenone
Progesterone	

### Regimes of Progesterone Therapy

It has been given along with oestrogen regime (Table 53.2).

**Table 53.2: Comparative doses of progesterone**

Types of Progesterone	mg available	Sequential minimum Effective dose/day x12 days /month	Combined Continuous
Dydrogesterone	10 mg	10 mg	10 mg
MPA	10 mg, 5 mg, 2.5 mg	5 mg	2.5 mg
Norethisterone	5 mg	1 mg	0.3 mg
Norethindrone	5 mg, 1 mg	2.5 mg	0.50 mg
Neogest	0.075 mg	0.150 mg	0.075 mg
Vaginal Micronised	100, 200, 400 mg	200 mg	100 mg
Oral micronised	100, 200, 400 mg	300 mg	200 mg
Cyproterone Acetate	50 mg, 1 mg	1 mg	—

The two main concerns are intolerance and adverse effects. Intolerance can be circumvented by assessing the individual patient's symptoms, altering the preparation, tailoring the dose and choosing a non oral route of administration.

### Present Scenario of HT Risks and Contraindications

#### Key Points

- There may be a small increase in breast cancer risk after several years of HT, although this continues to be debated.
- Progestogens added to the HT regimen largely eliminate any increased risk of endometrial cancer. If hysterectomy has been done then only oestrogen can be given.
- The risk for venous thromboembolism (VTE) is increased approximately twofold in current, but not former, users of HT, although the absolute risk is still very low.
- HT should be given for the shortest period in smallest dosage possible for symptomatic relief only.

### HT IN SPECIAL CIRCUMSTANCES

**Gallbladder disease:** The risk of gallbladder disease (cholelithiasis, cholecystitis) and cholecystectomy is increased in women taking HT. This effect was seen in women taking oestrogen only as well as oestrogen/progestin combination therapy. But after cholecystectomy HT can be taken.

**Ovarian cancer:** There may be a weak association between the prolonged use of oestrogen and ovarian cancer, but no epidemiological evidence has been established.

**Myocardial infarction (MI):** There does not appear to be an overall effect on the rate of fatal MI associated with an HT regimen, although the EPT arm of the WHI trial noted an increase in the rate of nonfatal MI. The oestrogen-only arm did not show an increase in MI. HT should not be used in MI cases and if women who are using HT and MI occurs they should stop HT.

**Alzheimer's disease:** Hormone therapy adversely affects global cognition, which includes memory and other basic mental abilities including concentration, language, and abstract reasoning. In particular, EPT doubled the risk of dementia in older women. In the ET group, there was a weaker, but similar trend in the results.

**Colorectal cancer:** The WHI oestrogen-progestin (EPT) arm confirmed that HT lowers the risk of developing colon cancer. The oestrogen-only arm did not show a reduction in colon cancer. However, HT should not be used solely for colon cancer prevention and women taking HT still need colorectal cancer screening at the recommended intervals.

#### Contraindications to HT

**Unexplained vaginal bleeding and pregnancy:** These are temporary but absolute contraindications to HT.

**Past history of breast cancer or endometrial cancer:** While usually considered contraindications to HT, short-term use for severe menopausal symptoms may be considered with proper precautions.

An increasing number of younger women are being cured of breast cancer, and some of these women may require treatment for severe vasomotor symptoms or significant vaginal atrophy. Short-term oral or transdermal HT or intravaginal oestrogen may be considered after consultation with an oncologist.

Most oncologists agree that women with past history of stage I endometrial cancer that has been successfully treated may safely use HT if it is otherwise indicated.

*Women with a past history of venous thrombosis* are at increased risk for recurrence; however, taking OCPs or HT confers an overall low increase to this risk of recurrence.

*Family history of premenopausal breast cancer:* In the Iowa Women's Health Study there was not an increased incidence of breast cancer in HT users with a family history of breast cancer, relative to those HT users without a family history of cancer.

*Hypertriglyceridaemia:* Oral oestrogens are contraindicated because of the danger of precipitating pancreatitis. Transdermal oestrogens or intravaginal oestrogens, which avoid the first-pass hepatic effect, do not carry this risk.

*Chronic liver disease:* Oral HT is a relative contraindication. Again, transdermal and intravaginal oestrogen avoid the first-pass hepatic effect of oral HT.

*HT is not contraindicated* in these clinical settings where many practitioners have often been reluctant (often unjustifiably so) to recommend oral contraceptives; OCPs have much more potent oestrogenic effects than HT. These conditions include:

- Endometriosis
- Fibrocystic breast changes
- Hypertension
- Mastalgia
- Migraine headaches
- Obesity
- Tobacco use
- Uterine leiomyomata (fibroids)

### Gonadomimetic Agents

A widely acting gonadomimetic hormone (with a combination of all oestrogenic, progestogenic and androgenic actions) known as Tibolone is also included as a form of HRT. The pharmacological agent is not an oestrogen, progestogen or androgen. It is called STEAR.

*Temporal implications of HRT use:*

- The temporal implications of HRT use may be differentiated into the following patterns of use:
- Short term HRT implies use for 2-3 years
- Long term HRT implies use for more than 5 years. (This is to be differentiated from long cycle therapy)
- And now to add a multifocal aspect is:

- *HRT Relayed Placement:* Where changes of the HRT types and forms are made over a period of time, shifting from the initial use of oestrogen-progestogen therapy to gonadomimetic use, to raloxifene and finally in some handing over to the non-hormonal agents or to vaginal oestriol.
- This placement of various therapies in a woman's postmenopausal lifespan with a view to maximizing benefits and minimising risks of individual groups of hormones gives the women reason to want to continue with it over long-term.
- *Concomitant Multiple hormone therapy:* Where simultaneous administration of some form of HRT takes place along with another HRT form (e.g. oestrogen-progestogen combined with raloxifene, oestradiol combined with oestriol or another route (e.g. Oral EPRT with vaginal oestriol).
- *Concomitant Multimodal Therapy:* When HRT is variably combined with another therapeutic modality (e.g. HRT with Bisphosphonates and calcium, HRT with antioxidants, micronutrients, multivitamins, and calcium). These combinations may need to be considered for maximal therapeutic outcomes. Hence, their duration of use would vary along with the risk benefit connotations and choice of the individual woman.
- *Long term intermittent therapeutic HRT:* Implies the use of 6-12 weekly EPRT or local vaginal ERT intermittently for recurring urogenital symptoms.

### ANDROGENS IN MENOPAUSE

While no testosterone products have received FDA approval for treating symptoms of sexual dysfunction in women, some women may benefit from testosterone therapy. Now it is recommended that postmenopausal women may be candidates for testosterone therapy if they complain of symptoms of decreased sexual desire associated with personal distress and are unable to identify another cause for their sexual concerns.

Foremost, other physical, psychological, and emotional relationship factors that may influence sexual function must be ruled out.

Once other factors have been ruled out, the primary candidates for androgen therapy are women with significant, near-total androgen depletion.

- These include women with loss of adrenal or ovarian function, which may be caused by Addison's disease or

- Bilateral oophorectomy.
- Women with premature ovarian failure of auto-immune origin and
- Women with Turner's syndrome may also have abnormally low androgen levels and may benefit from androgen therapy.

While transdermal patches are currently available for use in men, these patches are not appropriately dosed for use in women.

Testosterone is readily absorbed through the skin. Patches delivering lower doses of testosterone ranging from 150 mg/d to 300 mg/d are currently being studied for use in women. Transdermal testosterone gels, creams, and ointments have been approved in the United States for use in men. However, because these products deliver high doses, women may experience masculinising effects with their use. These formulations have not undergone

rigorous trials and quality-control testing. Still not approved by FDA for use in women.

*Phytoestrogens and isoflavones:* Soy products or isoflavones, either through diet or supplementation, may not reduce the incidence of hot flashes. Inconsistencies among studies to date may be explained by different doses, products, sources, and processing.

*Herbal preparations and dietary supplements:* Black cohosh, dong quai, evening primrose oil, flaxseed, ginseng, progesterone creams, red clover, and wild yam extract are commonly used but poorly studied.

So to conclude HT is to be tailor-made according to needs of perimenopausal or postmenopausal women and with informed consent and follow-up of these patients is must.

# CHAPTER 54

## Hysterectomy and its Aftermath

Indications for Hysterectomy	884	Should the Ovaries be Removed?	887
Types of Hysterectomy	884	The Aftermath of Hysterectomy	889
Routes of Hysterectomy	886		

### INDICATIONS FOR HYSTERECTOMY

Hysterectomy is a relatively easy operation to perform and is often easiest when least necessary. Many women die annually as a result of having this operation unnecessarily. It has even been said by some gynaecologists that, once a woman's family is complete, the uterus is *a foreign body* which should be removed. Many perform the operation merely at the request or demand of their patients who are led to believe that all their troubles originate in their pelvic organs and that they will be cured by 'having everything removed'. The surgeon lacking in conscience or care to make an accurate diagnosis can take a similar view, and so resorts to hysterectomy on the slightest pretext and for indications such as 'chronic pelvic pain' of unknown aetiology or chronic cervicitis. It is not exaggerating the situation to say that an ever-ailing woman is sometimes deprived of her uterus and adnexa so that the gynaecologist can thereafter shun responsibility for her care, on the grounds that there is nothing left in 'this department' which can possibly cause her symptoms.

Even for the woman who does not wish to have more children the uterus is not an organ to be discarded lightly. The very knowledge that she is 'normal', and the recurrent evidence of this by way of menstruation, is psychologically if not physically important.

The indication for hysterectomy in any case must therefore be clearly defined, and should be one for which more conservative treatment is not likely to be efficacious.

### TYPES OF HYSTERECTOMY

#### Total Hysterectomy

This involves removal of the whole uterus including the cervix.

#### Subtotal Hysterectomy

In this operation the vaginal part of the cervix and a variable amount of the supravaginal cervix are not removed.

### Advantages Over Total Hysterectomy

- The operation is technically easier and involves less risk to the ureters, bladder and rectum. For the experienced operator the difference in this respect is negligible, except in some exceptionally severe cases of endometriosis or of advanced ovarian cancer; inexperienced surgeons should not be carrying out hysterectomy.
- Many now believe that it reduces the risk of subsequent prolapse by preserving the integrity of the supporting ligaments.
- The subtotal operation does not disturb the anatomy and length of the vagina, and does not leave a scar in the vault. Coitus is therefore not affected. This argument is largely theoretical because the vagina is not usually shortened materially in the total operation and is, in any case, capable of stretching to accommodate the phallus.
- Retention of the cervix is said to be advisable because its mucus secretion helps to lubricate the vagina. This argument may have some substance but the fact remains that, so far as coitus is concerned, lubrication depends on Bartholin's glands rather than on the cervix.
- Lower urinary tract dysfunction does not occur.

### Disadvantages Compared to Total Hysterectomy

- The cervix remains as a potential site for cancer. Cervical stump carcinoma is relatively common where subtotal hysterectomy is frequently practised, its incidence varying from 2 to 6 per cent of all cases of cancer of the cervix. Sometimes the cancer is present in either the cervix or corpus at the time of operation but passes unrecognised. Excluding such cases it is estimated that there is a 0.5-1.0 per cent risk of cancer of the cervix developing in the 10 years following subtotal hysterectomy.
- Not infrequently, the remaining portion of the cervix causes symptoms of which the commonest are chronic discharge and dyspareunia. Menstrual or ovulation bleeding can also occur, especially if the isthmus is not removed. For one or other reason, excision of the stump is often necessary at a later date.
- If the supports of the vagina and uterus are slack, prolapse is more likely after subtotal than after total hysterectomy.

In view of these considerations, subtotal hysterectomy is seldom practised by gynaecologists, and then only for some special reason such as the presence of dense adhesions obliterating the pouch of Douglas, making the total operation unusually hazardous. A few gynaecologists prefer it in the case of the younger woman who does not have any prolapse, whose cervix is free from injury and infection and whose exfoliated cells have normal microscopic appearances.

### Panhysterectomy

This is an old term, the meaning of which is in dispute. Some use panhysterectomy to mean that the tubes and ovaries as well as the whole uterus are removed, others regard the term as being synonymous with total hysterectomy. To avoid confusion the term is best discarded in favour of the descriptive term 'total abdominal hysterectomy with bilateral salpingo-oophorectomy'.

### Radical Hysterectomy

Rutledge has defined five classes of hysterectomy in cases of malignancy, depending on the extent of resection.

Class I – Extrafascial hysterectomy with bilateral salpingo-oophorectomy

Class II – Modified radical hysterectomy which is the original Wertheim hysterectomy. In this the medial half of the cardinal and uterosacral ligaments are also removed as well as those pelvic lymph nodes which are enlarged.

Class III – Radical hysterectomy. This is the modified Wertheim's operation as described by Meigs. It includes complete pelvic lymph node dissection, removal of almost the whole of the cardinal and uterosacral ligaments and the upper one-third of the vagina.

Class IV – Extended radical hysterectomy. This includes removal of the periureteral tissue, superior vesical artery and up to three-fourths of the vagina.

Class V – Partial exenteration. This is rarely performed. Here portions of the distal ureter and bladder are also dissected.

### Schauta's Operation (Radical Vaginal Hysterectomy)

See Chapter 29.

## ROUTES OF HYSTERECTOMY

### Abdominal Hysterectomy

This means total or subtotal hysterectomy carried out through an abdominal incision.

### Vaginal Hysterectomy

Here the approach is through the vaginal vault and the operation is nearly always of the total hysterectomy type. The tubes and ovaries can be removed as well if the need arises. This operation is technically easy for the expert, even when there is no prolapse of the uterus, provided the pelvis is relatively free from adhesions and the uterus is not larger than the size of a 10-week pregnancy. When the uterus is enlarged further by leiomyomas, its vaginal removal is still possible if the tumours are shelled out during the operation. A large uterus can also be hemisected and removed vaginally, one-half at a time.

### Advantages Over Abdominal Hysterectomy

- Vaginal is generally safer than abdominal hysterectomy and carries a very low mortality rate.
- Postoperative shock and discomfort are negligible; often the patient scarcely knows she has had an operation. Earlier ambulation decreases the need for nursing care. There is a lesser requirement for analgesics. Pulmonary function is better.
- Lesser bowel handling and early ambulation result in earlier return of bowel function and lesser requirement for intravenous fluids.
- The operation is better tolerated by the elderly, the obese and those with associated medical disorders.
- The operation leaves no abdominal scar and involves little risk of later complications such as hernia, adhesions and intestinal obstruction, and avoids others such as infection or wound dehiscence.
- An associated prolapse of the vagina can be corrected at the same time.
- Postoperative thrombosis and embolism were said to be rare in the past but occur with equal frequency under conditions of modern surgery.

### Disadvantages Compared to Abdominal Hysterectomy

- The excision is generally less wide than in the case of abdominal hysterectomy so the operation is not ordinarily carried out for malignant disease.

- The operation is stated to be difficult and unsafe in the presence of dense adhesions caused by pelvic inflammatory disease, endometriosis or previous pelvic surgery. Its scope in these cases depends very much on the skill and experience of the operator. In fact, it may be much safer and easier than an abdominal approach.
- It offers little opportunity to inspect other abdominal viscera.
- It is alleged that vault prolapse (eversion of the vagina) is more likely than after abdominal hysterectomy. This is not true if the operation is well done, if all redundant pelvic peritoneum is excised in every case, and if slackness of the vaginal supports is recognised and treated simultaneously (*see* Chapter 16).

In general it can be said that vaginal hysterectomy is preferable to abdominal hysterectomy, so long as the above technical hindrances are not present, and so long as the indication for hysterectomy is not malignant disease. In regard to the latter, however, exceptions can be made. Thus, early stage carcinoma of the body of the uterus in a woman who is obese and generally unfit may be better treated by vaginal hysterectomy.

### Laparoscopy-assisted Vaginal Hysterectomy (LAVH)

Laparoscopy-assisted vaginal hysterectomy is of greatest benefit in those conditions in which vaginal hysterectomy is relatively contraindicated. It should be used to convert an abdominal hysterectomy to a vaginal procedure and not to convert a vaginal hysterectomy into a laparoscopic one. The latter is associated with increased operating time, cost and pain at abdominal puncture sites in such a situation.

Thus, LAVH is ideally suited in cases of endometriosis, known pelvic adhesions, pelvic inflammatory disease or adnexal masses where a vaginal procedure would not be possible (*see above*). It is also indicated in Stage I endometrial cancer. LAVH permits laparoscopic assessment of the pelvis and division of pedicles up to the level of the uterine artery. The rest of the procedure can then safely be done from below.

Several types of LAVH can be performed depending upon the degree up to which surgery is carried out laparoscopically, e.g. adhesiolysis and resection of endometriosis, detachment of adnexa, bladder dissection, or uterine artery ligation, before proceeding to the vaginal



hysterectomy. Several alternative laparoscopic techniques for hysterectomy have been described which include the following.

### Laparoscopic Supracervical Hysterectomy

In this procedure a subtotal hysterectomy is done laparoscopically and the fundus removed through an enlarged umbilical incision or via a posterior colpotomy. The advantages and disadvantages are the same as for a subtotal hysterectomy.

### The CASH Procedure

This procedure was described by Semm. CASH is an acronym for Classic Abdominal SEMM (Serrated Edged Macro-Morcellated) Hysterectomy. Laparoscopic supracervical hysterectomy is followed by 'coring out' of the cervical canal by a special serrated resection device. This additional procedure should decrease the risk of cervical cancer in the stump, while retaining the benefits regarding prolapse and sexual function. Long-term results are awaited.

### Laparoscopic Doderlein Hysterectomy

After the adnexa have been detached laparoscopically, an anterior colpotomy is made to draw the uterine fundus into the vagina and complete the rest of the procedure, including the ligation of the uterine arteries, vaginally as with Heaney's technique.

The choice of technique is largely a preference of the individual operator.

### Advantages of LAVH

- An abdominal procedure can be converted to a vaginal one, even in the presence of complications
- Overall morbidity is reduced
- Hospital stay and recovery time are less than that for abdominal hysterectomy

### Disadvantages of LAVH

- Special equipment and training is required
- Baseline cost is higher
- Operative time is increased
- Major complications encountered include injury to major vessels, pulmonary embolism and injury to bladder and bowel.

## SHOULD THE OVARIES BE REMOVED?

The ovaries deserve even more respect than the uterus because their endocrine function has such a wide-spread effect on general well-being. Yet there are some who still hold the view that if the uterus is to be removed it is just as well to remove the ovaries because the ovaries may later become the seat of neoplastic disease; the ovaries may become cystic or painful; removal of the uterus invariably causes the ovaries to cease function within 2-3 years. These and other arguments are not always valid and the situation is as follows:

- If the ovaries are hopelessly diseased, as in the case of ovarian abscess, they may have to be sacrificed with the uterus — even if the woman is young. Here it must be remembered, however, that bilateral ovarian disease invariably leaves some normal tissue which can be found if looked for.
- If the operation is for malignant disease of the uterus, then removal of the ovaries allows a wider excision and is ordinarily indicated. Even in this circumstance, however, young women deserve special consideration. In them, ovarian function can often be conserved without serious prejudice to the cancer recurrence rate.
- When the indication for hysterectomy is bilateral ovarian tumours in a woman aged more than 45 years, both ovaries and tubes should be removed. But for unilateral Stage IA ovarian cancer in a young woman there is a strong case for not removing either the uterus or the other ovary.
- If the ovaries appear normal then it *may* be justifiable to remove them in women over the age of 50 years on the grounds that it removes a possible site for cancer. In younger women, at least one ovary should be conserved. Those who are impressed by the risk of subsequent cancer have usually become prejudiced by a single unfortunate experience. This is a natural reaction which influences all medical persons in their views on various matters, just as one is likely to be prejudiced the other way if malignancy has never occurred when an ovary has been left.

Many attempts have been made to compute statistically the chance of a woman developing ovarian cancer after hysterectomy, with an astonishingly wide variation in the conclusions reached. Again, in some, there may be an element of bias. The most convincing reports suggest that the risk of cancer arising in an ovary

during the 10 years after hysterectomy is 1.5 to 2 per 1000 cases. The chance of a benign tumour is rather higher, perhaps 1 in 100.

These statistical chances are less than those to which all women of comparable age are exposed. The chances are lower because only ovaries which are seen to be normal are conserved at the time of hysterectomy.

- If ovaries are conserved, trouble can arise as a result of their becoming painful and cystic when the indication for the operation was pelvic inflammatory disease, when they become buried in adhesions; otherwise it is rare. Intermittent ovulation pain may continue but *most one-sided pains after hysterectomy do not originate from the ovary*. They are probably caused by the condition (for example, spastic colon) for which the hysterectomy was wrongly undertaken.
- Contrary to an earlier belief that the ovaries ordinarily atrophy and cease to function as a result of hysterectomy, it is now established by hormone assays, vaginal smears, temperature charting and symptomatology that ovarian function continues normally in *most* women until the natural age of menopause. In *some* cases ovarian function does cease earlier (*see* Chapter 5). Some of these may be explained by a naturally occurring premature menopause, others perhaps by interference with the blood supply to the ovary following hysterectomy.

The incidence of *severe* menopausal symptoms following hysterectomy in premenopausal women is lowered from 50 to 1.5 per cent if at least one ovary is conserved.

- Not only does the removal of both ovaries from premenopausal women commonly result in vasomotor symptoms and other menopausal changes; it is followed during the next 3-6 years by osteoporosis more frequently and in more severe form than is the natural climacteric.

Twenty per cent of women subjected to a surgical menopause later develop symptom-producing hypertension and arteriosclerosis; it is questionable whether this is a greater than expected incidence. But it is clearly established that removal of both ovaries before the age of 40 years increases 6-7 times the chance of a woman subsequently dying from coronary thrombosis. The effect takes 14-15 years to develop and is not apparent when bilateral oophorectomy is performed on older women:

- Those who practise bilateral oophorectomy routinely at the time of hysterectomy, emphasise that replacement therapy with oestrogens and progestogens adequately compensates for loss of normal ovarian function. This is not entirely true. Though it does protect against osteoporosis and several other problems (*see* Chapter 5) there is no clear evidence that such treatment prevents subsequent coronary artery disease. Meanwhile, the treatment itself carries its own hazards and difficulties which lead to poor compliance. Moreover, the duration for which such therapy can be safely continued is not yet clearly established. This is especially important for young women undergoing bilateral oophorectomy.

It is difficult not to conclude that the practice of routine bilateral oophorectomy with hysterectomy has an insecure basis. The disadvantages far outweigh the advantages. Unless there be some special indication, it is generally wise to conserve at least one ovary in all women who are still menstruating up to the time of hysterectomy.

### Should the Uterus be Removed at the Time of Bilateral Oophorectomy?

There are cases of ovarian cancer in which the findings at laparotomy indicate that the outlook is so poor that it is not worth adding hysterectomy to bilateral salpingo-oophorectomy.

More important is the fact that some women are still treated by bilateral salpingo-oophorectomy without hysterectomy when they suffer from widespread pelvic infection or endometriosis. Such a procedure may, on rare occasions, be justified by technical difficulties in excising the uterus safely; on other occasions it may be possible to perform a subtotal hysterectomy without endangering adjacent organs. A uterus left *in situ* without the ovaries is functionless. Moreover, it is likely to be permanently damaged by the conditions mentioned above. Even if it is not, its chance of developing subsequent disease, including cancer, is quite high. Again, the presence of the uterus hinders hormone replacement therapy which the artificial menopause might call for and rules out a subfascial implant of an oestrogen. Generally, therefore, removal of both ovaries calls for simultaneous total hysterectomy.

With advances in assisted reproduction technology, however, it is now possible for a woman who has

undergone bilateral oophorectomy to receive into her womb an embryo conceived through oocyte donation and *in vitro* fertilisation and carry the foetus to term. These exciting new developments, therefore, make it necessary for each case to be treated on its own merits.

### THE AFTERMATH OF HYSTERECTOMY

Excluding the effects of oophorectomy, the results of hysterectomy are extraordinarily good — provided the indications for it are good. There are no patients more grateful than those who have been relieved of the symptoms of leiomyomas, endometriosis and pelvic infection, and of intractable dysfunctional bleeding, by having their uteri removed. What then of the many women who, after hysterectomy, are left chronic invalids or full of complaints such as headache, depression, urgency of micturition, backache, nausea, pelvic pain, sexual unresponsiveness, dyspareunia, marital disharmony and the like?

There are many such, and for two main reasons:

- In the majority the operation was carried out for the wrong indication and unnecessarily. These women suffered the same type of symptoms previously, or at any rate they are of the complaining type with a background of emotional disturbance. Often they are fussy, continuously demanding attention and sympathy from a husband who is perhaps too

considerate. The very idea of 'having the womb removed' surrounds them with an aura of mystery and fragility to the unknowing and unsuspecting male.

Women are referred to psychiatrists much more commonly after hysterectomy than after any other operation. This is not usually because psychiatric breakdown results from surgery; it is because hysterectomy is often performed for symptoms caused by psychiatric instability.

- Women and their husbands misunderstand or have never been told what the operation involves. So they often expect to have menopausal symptoms, even though the ovaries are not removed. They may believe that coitus should not or cannot be practised after the operation; they may fear it will cause injury.

Such happenings emphasise the need for the medical attendant to see that patients are counselled in these matters; it should always be explained clearly that hysterectomy by itself should have no physical effect except to cause amenorrhoea, and should not materially affect a woman's way of life, sexual or otherwise.

The woman who puts on weight after hysterectomy blames the operation for it. The cause of the obesity is self-indulgence in foods, chocolates and sweets brought by sympathetic friends and relatives, and a refusal to resume full and natural physical activities quickly. The same is true even if both ovaries have been removed.

# Conditions of the Lower Intestinal Tract

Rectal Prolapse	890	Irritable Bowel Syndrome	894
Incontinence of Faeces and Flatus	892	Pruritus Ani	895
Diarrhoea	893	Rectal and Anal Pain	896
Difficult Evacuation	893		

The close anatomical relationship between the lower bowel and the genital tract brings certain anal and rectal conditions within the purview of the gynaecologist; the following comments represent this particular view and do not aim to be all-embracing or comprehensive.

## RECTAL PROLAPSE

### Rectal Prolapse in Childhood

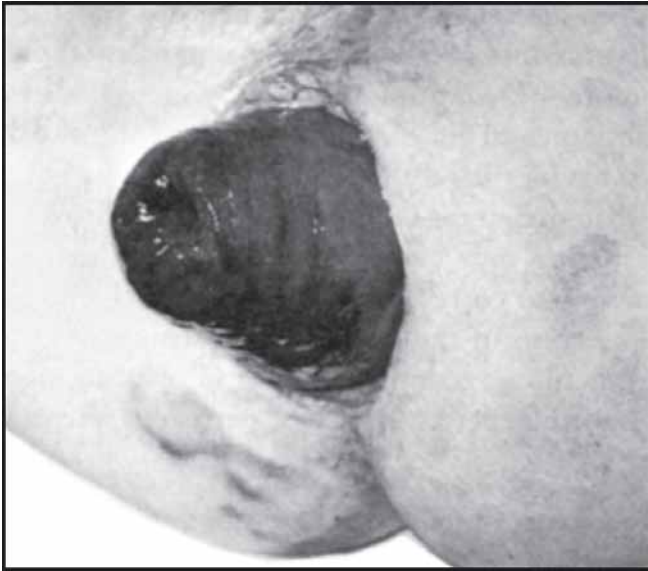
Spontaneous prolapse of the rectum, occasionally seen in young children, is usually self-curative and calls for nothing more than replacement followed by supporting pads and strapping.

### Rectal Prolapse in the Adult

This distressing condition is, in women, mainly a disease of middle and old age. It is often associated with genital prolapse or the patient gives a past history of treatment for such. The anal and rectal mucosa becomes inverted through a lax sphincter to produce a red mass of prolapsed bowel which may be several inches in length (Fig. 55.1). Although reducible on lying flat, the prolapse occurs with each bowel action and with standing or walking. Faecal incontinence is usual and the prolapsed tissues bleed, ooze mucus and ultimately become ulcerated.

### Causes

Rectal prolapse is not caused by obstetrical injury, or by repeated straining at stool, although these can be activating factors. It is not dragged down by haemorrhoids but is said sometimes to follow forcible and excessive surgical dilatation of the anus in the elderly. Mostly, however, the disease reflects an inherent weakness in the supporting perirectal fascia which becomes worse with advancing years. Another underlying fault is a sliding hernia of the uterorectal peritoneal pouch. This is why enterocele and vault prolapse are common associates. It has also been suggested that there is often a neurological component.



**Fig. 55.1:** Rectal prolapse in a woman aged 70 years who had already had five previous operations for the condition. She had also had the uterus removed and a plastic operation for genital prolapse. Two further operations designed to remove the redundant mucosa and to tighten the perineal and perianal tissues also failed, but the patient managed to maintain a good degree of comfort by controlling the prolapse with the device shown in Fig. 55.2

## Treatment

### *Surgical*

The condition is extremely difficult to cure and women who suffer from it often give a history of several unsuccessful operations. The aim of surgery is to remove the intussusception and to prevent it from recurring. Most methods of repair are by the transabdominal approach but in elderly or unfit patients a transperineal approach may be more appropriate, especially if pelvic organ prolapse is associated. Surgical procedures include:

- The rectal sling operation (Ripstein). A sling of teflon or marlex wraps the fully mobilised rectum anteriorly and attaches it to the presacral fascia.
- Support of the rectum intra-abdominally (Wells' operation). A polypropylene mesh wraps the rectum posteriorly only and is sewn to the sacrum. It results in less obstruction of the rectum but may be followed by pelvic sepsis.

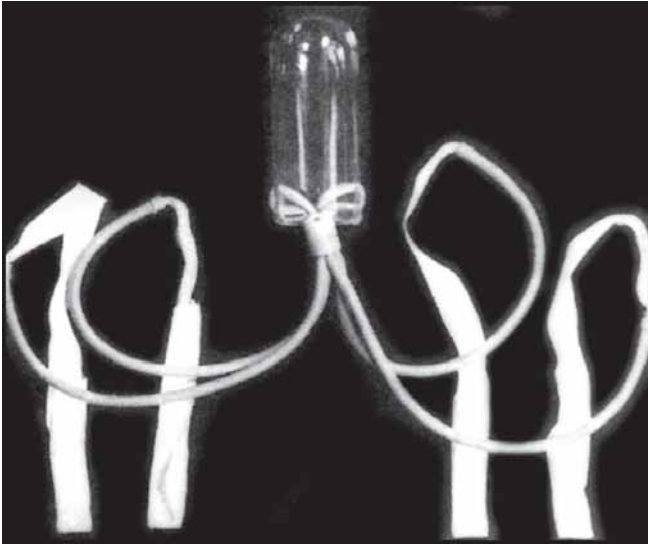
Both the Ripstein and Wells' operations can be done laparoscopically as well.

- Anterior resection of the redundant colon loops followed by primary anastomosis.
- Transabdominal rectosigmoid resection and rectopexy. This is a composite procedure. The rectum is fully mobilised to the level of the pelvic floor musculature. The redundant rectum and sigmoid are resected and a primary anastomosis done. The endorectal tissue and peritoneum on each side of the mid-rectum are then sutured to the presacral fascia. This is the preferred method in previously failed operations.
- Perineal rectosigmoidectomy. This is an excellent choice for elderly patients with prolapse extruded at least 3 cm. The prolapsed rectum and redundant sigmoid colon are excised endorectally.
- The modified Delorme procedure is suitable when the prolapse is located within the anus or comes out less than 3 cm through the anus. The submucosa from the dentate line is stripped circumferentially with electrocautery and continued proximally till taut and then resected. The proximal cut end is then anastomosed to the dentate line incorporating the denuded rectal wall to eliminate the dead space. Both these procedures are well tolerated with little postoperative pain.
- Ringing the anal canal with stainless steel wire or a silastic or nylon suture may be suitable in the elderly but it often fails or leads to infection.

No matter what operation is carried out on the bowel, it must be accompanied by cure of any pelvic organ prolapse which may also be present. The recurrence rate of all procedures is up to 10 per cent at 3 years follow-up.

### *Palliative*

In the very old and feeble, or when all forms of surgery have failed, the rectal prolapse can be controlled to some extent by various pads and devices supported by tapes to a belt. One of these is the McCullagh plastic tube which was ordinarily used for genital prolapse (Fig. 55.2). More hope of good relief is offered by a perspex plug which carries a muscle-stimulating electrode energised by a small portable tetanic current generator. By improving sphincteric tone this type of device can control both the rectal prolapse and faecal seepage.



**Fig. 55.2:** The McCullagh supported pessary. A polyethylene vaginal obturator is supported by protected tapes which are tied to a waistband. This can be used to control rectal as well as pelvic organ prolapse, but is seldom used nowadays

## INCONTINENCE OF FAECES AND FLATUS

Faecal incontinence is more common in women than in men. Minor faecal incontinence is the inadvertent passage of flatus or soiling in the presence of diarrhoea. Incontinence of flatus is generally more embarrassing and troublesome than faecal incontinence. The latter, unlike the former, can be controlled to a large extent by the woman learning to keep the stools well formed and by using muscles such as the levatores ani in place of damaged anal sphincters. The escape of flatus *per vaginam* has to be distinguished from the escape of air which enters a relaxed introitus.

Major faecal incontinence is the inadvertent passage of formed stools at least twice weekly.

### Causes

Usually minor faecal incontinence follows damage to the anal sphincters whereas major faecal incontinence is usually caused by neurological injury, stretched, damaged or atonic anal sphincters.

- Obstetrical injuries such as complete perineal tear; puerperal atony is often only temporary
- Rectal prolapse, condylomata, second-degree haemorrhoids
- Operations on the anus, e.g. anal stretching, haemorrhoidectomy

- Debility and old age
- Impacted faeces.

## Neurological Conditions Affecting The Nervous Control of The Sphincters

- Prolongation of pudendal nerve latency following vaginal delivery
- Organic disease of the central nervous system
- Damage to the cauda equina by intrathecal injections of anaesthetics and of neurotoxic agents used for intractable pain
- Cordotomy
- Mental deficiency, senile change and psychological disturbances.

## Fistulas

See Chapter 15.

## Congenital Malformations

See Chapter 13.

## Descending Perineum Syndrome

In this syndrome the perineum balloons down below the level of the bony pelvis, especially on straining. The pudendal nerves are stretched and the pelvic muscles denervated. This leads to a constant perineal aching pain in the upright position, anal incontinence and a feeling of incomplete emptying caused by prolapse of the anterior rectal wall mucosa into the anal canal. There may also be a solitary mid-rectal ulcer caused by the excessive straining which may bleed and is sometimes, painful.

### Treatment

Injured or inherently defective anal sphincters can usually be reconstituted sufficiently well to restore continence; fistulas can be closed. Rings of fascia, or of unabsorbable material, can be inserted subcutaneously around the anus to replace sphincters. The tendon of the gracilis muscle has also been used.

Faecal incontinence due to senility or a nerve lesion calls for a low-residue diet and good nursing rather than surgery.

The anterior rectal mucosal prolapse in the descending perineum syndrome can be treated by sclerotherapy or by surgical excision. Perineal body descent can be corrected surgically. The solitary rectal

ulcer syndrome may require rectopexy if associated with rectal prolapse.

### DIARRHOEA

Diarrhoea has many possible causes but it is necessary to emphasise that this symptom can be caused by pelvic lesions which irritate and 'hurry' the bowel. These are pelvic peritonitis, pelvic abscess, pelvic haematocele or antibiotic therapy - conditions which should always be suspected when a woman develops diarrhoea following a gynaecological operation.

### DIFFICULT EVACUATION

#### Causes

##### *Constipation*

It is sometimes said that all women are constipated. This is not true but many women think they are. They develop a phobia about bowel action and encourage the same in their daughters. Their habit of taking laxatives regularly is good for manufacturing chemists but bad for the physiology of the lower bowel. These women think that constipation causes headaches, lethargy and all manner of ills. In fact it is without any ill-effect, as is shown when bowel action is deliberately suppressed for 5-10 days after certain operations.

Nevertheless, the accumulation of large masses of hard faeces in the rectum can cause dyspareunia; their passage is painful and can result in fissures.

##### **Pregnancy and Puerperium**

Constipation is common in pregnancy; difficulty in evacuation for 1 or 2 weeks after delivery is almost the rule and can cause considerable distress, even collapse from straining. In both circumstances the factors responsible are: atony of the bowel; stretching of the muscles of expulsion; and physical inactivity. An acute episode in the puerperium is treated by a simple enema or stimulant suppository. Thereafter the situation is corrected by muscle exercises, fluids and by mild laxatives if necessary.

##### *Rectocele*

The ballooning forward of the rectum into a rectocele causes difficulty in evacuation unless the posterior vaginal wall is pressed back digitally.

### Constriction of The Rectum and Anus

#### *Malformations*

See Chapter 13.

#### *Stricture Following Infection*

The main causes under this heading are lymphogranuloma venereum and granuloma inguinale.

#### *Stricture Following Operation or Radiotherapy*

Postradiation rectal strictures may occur in cases of carcinoma of the cervix and may develop several months or years after treatment.

#### *Pelvic Tumours*

Benign tumours such as cysts and leiomyomas rarely cause difficulty in emptying the bowel, even when they are so impacted as to result in retention of urine. The same applies to a retroverted gravid uterus. A retroverted non-pregnant uterus *never* causes bowel symptoms. A tumour which causes dyschezia is usually malignant and may arise from the vagina, uterus or ovary.

#### *Endometriosis*

When this disease involves the rectum some narrowing may result but the main complaint of the patient is pain on defaecation.

#### *Carcinoma of the Rectum*

While this may be associated with a change in bowel habits, there is also likely to be some rectal bleeding.

### Faulty Powers of Expulsion

Neurological disorders, old age, debilitating disease and physical inactivity constipate by causing atony of the voluntary muscles of expulsion and of the involuntary muscles of the bowel.

### Treatment

The treatment of specific conditions is described in the appropriate sections.

When constipation itself requires treatment the appropriate measures are as follows:

- An increase in the intake of fluid
- Regular physical exercise
- Regular habits
- A high-fibre diet with bran or other agents which increase stool bulk
- Liquid paraffin, or preparations containing it, are suitable for short periods of time but are contra-indicated for regular use because they may interfere with the capacity of the bowel to absorb vitamins; they may be carcinogenic; and they can cause pruritus ani.
- Saline laxatives and preparations containing mucilage or senna are more suitable for prolonged usage.
- Stimulant laxatives which act by increasing intestinal motility, such as bisacodyl, are often used but prolonged use should be avoided as they can eventually precipitate the onset of an atonic non-functioning colon and hypokalaemia.
- Enemas and stimulating rectal suppositories should not be used repeatedly, only as isolated procedures for clearing the lower bowel for specific indications.

### IRRITABLE BOWEL SYNDROME

The irritable bowel syndrome is a functional disorder which is twice as common in women as in men. It is mostly seen between the ages of 20 and 60 years, and is usually more troublesome during the week preceding menstruation to form part of the pre-menstrual syndrome. The resulting pain is therefore often mistaken for dysmenorrhoea. The patient suffers considerable discomfort over the course of the descending colon which is usually palpable as a cord in the left iliac fossa. Associated symptoms are constipation (which is the *result* and not the *cause* of the spasm), alternating constipation and diarrhoea, flatulence, and sometimes attacks of diarrhoea alone. With or without allied spasm of the rectum, colonic spasm can also be the basis of dyspareunia.

Caecal distension is commonly present as well; it causes similar symptoms but the pain is right sided. The caecum is palpably distended and tender.

These closely related conditions persist for many years with intermittent exacerbations related mainly to periods of nervous stress. The clinical picture is also described as the spastic colon.

The syndrome frequently leads to unnecessary appendicectomy, laparotomy for 'adhesions' and even hysterectomy for 'pelvic pain'.

### Causes

The underlying cause in a high proportion of cases, but not exclusively, is a state of nervous tension and neurosis. The resulting instability of the autonomic nervous system makes the colon irritable and 'on edge', ready to react to any stimulus or circumstance.

Affected women may be of anxious or emotional disposition, sometimes spoiled by mother or husband and always looking for sympathy. Domestic stresses, family illness and bereavement, financial worries, fear of cancer and similar factors are often present. Given such a background, specific factors which precipitate attacks of discomfort are the abuse of purgatives — women themselves, in the belief that the pain is due to constipation, often make matters worse by taking laxatives which have an irritant effect on the colon; certain foods which cause flatulence; a domestic crisis or other source of worry; the death of a relative or friend from cancer; and premenstrual tension.

### Diagnosis

The diagnosis of irritable bowel syndrome is readily made on the basis of the clinical features. Barium enema radiography confirms the spasmodic action of the bowel wall in 75 per cent of cases and excludes the presence of other lesions. This investigation is important, as is sigmoidoscopy in some cases, because this is such a common syndrome that it is easy to overlook the occasional presence of some organic lesion in the bowel which gives rise to similar clinical features. Diseases such as diverticulitis and carcinoma of the colon must therefore be excluded.

### Treatment

Once an organic lesion of the bowel is excluded, treatment is always on medical lines and never by surgery. In this respect the important measures are as follows:

- Reassurance and explanation of the situation to the patient and relatives; teach the woman to live with her symptoms



- Attention to the psychological and environmental factors which are nearly always present in the background
- A high-fibre diet and bran supplements
- Avoidance of laxatives which excite the gut. The pain is not caused by constipation but by muscle spasm of which constipation is merely a sign. Purgatives make the spasm worse. Saline laxatives, senna, or one of the mucilage preparations which make the stools big and soft, are helpful if taken regularly
- Antispasmodics with anticholinergic effects or those that have a direct effect on smooth muscle may be used when the pain is severe.

### Results

When the case is handled well, the results are good, although complete elimination of the discomfort is unusual and the symptoms tend to reappear during periods of stress; the woman should be warned of this and told to avoid surgery.

### PRURITUS ANI

This complaint is nearly as common as is pruritus vulvae and is equally distressing; the two sometimes occur together (*see* Chapter 43). The perianal skin may be pink or red but, in the chronic case, is usually white and thickened and keratinised. It shows epithelial changes similar to those found in the vulva and these have sometimes been ascribed to lichen sclerosus or leukoplakia. The affected skin frequently cracks, not only at the anal margin but also in the natal cleft. It very rarely undergoes malignant change.

### Causes

#### *Threadworms*

Infection with threadworms (*Enterobius vermicularis*) is the commonest cause of pruritus ani in children but is not common in adults. The pruritus is experienced mainly at night when the parasites leave the anus for the surrounding skin.

#### *Fungus and Other Infections*

In the majority of cases the symptom is a reaction to a low-grade infection of which there is likely to be a

primary focus elsewhere. Thus, pruritus ani is commonly associated with 'athlete's foot', erythrasma between the toe clefts, and candidiasis of the toe and fingernails, of the hard palate and of the bowel. Pruritus ani can complicate diabetes and the oral administration of broad-spectrum antibiotics.

#### *Drugs; Allergy*

Prolonged seepage of liquid paraffin taken as a laxative is said to cause pruritus ani but such an association is not commonly seen. Other laxatives such as phenolphthalein can cause an idiosyncratic reaction. The condition may represent an allergy to soap or other articles of hygiene.

#### *Haemorrhoids, Fissure In Ano*

These are alleged to cause pruritus ani and many sufferers are subjected to needless haemorrhoidectomy. Nevertheless, except in the case of pruritus limited to a discrete haemorrhoid, and except when anal tags form a nidus for infection, it is extremely doubtful whether these conditions ever cause pruritus.

### Treatment

Pruritus ani can last for years and there is a wide-spread idea that it is incurable. This is a pessimistic view and the results are good provided treatment is sufficiently conscientious and persistent. Any obvious cause must be eliminated but, if none is found, pruritus ani is best treated on the assumption that it represents a chronic fungus or other infection with a nidus elsewhere. Apart from treating the perianal skin, the infection must be eliminated by regular applications of fungicides (*see* Chapter 20). Local treatment comprises the following:

- Careful anal hygiene; this means *washing* with water and a good-quality soap after every act of defaecation. If this is practised daily without fail for months or years, complete relief is the rule.
- If further treatment is necessary, a fungicidal ointment or powder should be applied regularly after washing as described above.
- If these measures fail, oral antifungals should be tried.
- Steroid ointments and suppositories may give temporary symptomatic relief.

## RECTAL AND ANAL PAIN

### Fissure in ano

#### Pathology

A fissure is usually situated posteriorly as a tiny crack in the anal margin. It occurs in an acute form and also as a chronic indolent ulcer, but tends to heal more easily in women than in men. Often it is associated with haemorrhoids. A fissure is generally caused by the passage of bulky, hard stools and commonly develops during the days or weeks after delivery.

#### Symptoms

The main complaint is pain during defaecation, followed by a deep-seated throbbing ache for 2 or 3 hours afterwards. The aching is caused by rectal spasm and is extremely trying to the sufferer. The fissure often sheds a few drops of blood during defaecation but this stops immediately afterwards.

#### Signs

The crack or ulcer is visible on careful inspection. An attempt at digital rectal examination causes severe pain and spasm of the sphincters.

#### Treatment

Most fissures *in women* can be healed by conservative treatment. This consists of:

- Bed rest
- Keeping the bowels regular and the stools soft by habit, diet and liquid paraffin, and by avoiding straining at stool
- Supporting the anal ring manually during defaecation to prevent the crack from reopening
- Careful anal hygiene — washing with cotton wool swabs or preferably sitting in a warm bath after defaecation and at bedtime
- Applying a local anaesthetic ointment before defaecation and, when this is acting, passing an anal dilator which is left in place for a few minutes. This overcomes the spasm which is the cause of the pain and the basis for the fissure failing to heal. Gentle and careful dilatation of the anus in this way can be carried out by the patient two or three times daily. This alone will cure most fissures, and should in any

case be practised regularly after any operative treatment of the fissure.

If these measures fail, more active treatment consists of the following:

- Dilatation of the anus under caudal or general anaesthesia, probably the most effective of all treatments
- Incision of the internal sphincter
- Excision of the fissure.

### Haemorrhoids

#### Pathology

Most women of European stock, and probably all those who have a baby, develop haemorrhoids at some time; those with a family history of haemorrhoids and varicose veins suffer the most. Haemorrhoids develop as part of the pelvic congestion of pregnancy and are probably encouraged by atony of the vessel walls. They are, however, only painful *when they prolapse and become thrombosed* as a result of their strangulation by the anal ring; this is particularly likely to occur during the second half of pregnancy, or during and immediately after labour. Once the haemorrhoids are thrombosed they remain extruded and become swollen, tense, oedematous and tender; thereafter they may ulcerate. The thrombus begins to organise in a few days the swelling then subsides and the pain disappears; but the haemorrhoid remains as a small and more fibrous structure.

#### Treatment

##### Prevention

It is impossible to avoid haemorrhoids but it is often possible to prevent their becoming strangulated and painful. This is done by:

- Keeping the bowels regular and the stools easy to pass without straining
- Gentle replacement of prolapsed haemorrhoids immediately after defaecation
- Resting flat in bed for 15-30 minutes after defaecation to give the anal sphincter time to recover tone; this very valuable measure is carried out most efficiently by changing the bowel habit so that defaecation takes place at night immediately before retiring to bed.
- Avoiding standing with the pelvic floor muscles relaxed.

When haemorrhoids prolapse during the second stage of labour their replacement, then or immediately after delivery, is usually valueless; this is because the anal sphincter is so stretched that it cannot contain them. So they invariably thrombose to cause discomfort in the early puerperium.

### *Treatment of Strangulated Haemorrhoids*

The best treatment for 'an attack of piles' is rest. Two or three days of lying flat in bed will cure them more quickly than any other procedure. Lying is essential, sitting up makes the situation worse. The prone position, with the haemorrhoids at the highest level of the body, often brings quick relief.

Anaesthetic ointments and anal suppositories satisfy the patient that something is being done but are of little intrinsic value. Ice packs and cold compresses are more helpful. Hot baths should be avoided because, although temporarily soothing, they increase the congestion.

### Treatment Between Attacks

Treatment depends on the type of haemorrhoids. The application of rubber bands, cryotherapy or sclerotherapy are the most effective procedures and can be done without anaesthesia on an out-patient basis. Haemorrhoidectomy is now performed only when all other methods have failed. It is more appropriate for cases of internal and external haemorrhoids, but is not free from risk.

### Infections

Painful inflammatory states include perianal, intersphincteric and ischiorectal abscesses, and resulting fistula *in ano*. These are much more often seen in men than in women.

### Radiation Proctitis

Proctitis can be an immediate temporary reaction to radiation, or can appear many months or years later. In the latter circumstance, it causes intense pain which is throbbing and sickening in character, deep-seated and sometimes referred to the buttocks. This is accompanied by the passage of blood and pus when the lesion becomes ulcerated. On examination the anterior rectal wall feels indurated and is fixed by adjacent cellulitis. It bleeds on examination and a frank ulcer may be seen or felt. The

condition is thus often mistaken for a recurrence of malignancy.

Radiation proctitis is treated by keeping the motions soft and loose; local treatment with corticosteroids as enemas or suppositories; frequent hot baths; analgesics and antispasmodics; and temporary colostomy, which may become necessary for effective local treatment to be carried out.

### Proctitis

This may occur alone or in conjunction with ulcerative colitis. The measures detailed above may be appropriate but sulphasalazine enemas or suppositories may be required in addition to corticosteroids. A compound preparation with hydrocortisone can be inserted into the rectum two to three times daily.

### Endometriosis

When endometriosis is adjacent to the rectum — as it is when the lesion is in the pouch of Douglas, uterosacral ligaments and rectovaginal septum, and when it invades the rectal wall — a deep-seated discomfort results. This amounts to actual pain at the time of defaecation and is especially noticeable just before and at the time of menstruation. Endometriosis rarely penetrates to the bowel mucosa and does not often cause rectal bleeding.

### Malignant Disease

Carcinoma of the rectum, and carcinoma invading or approaching the rectum from any of the genital organs, invariably give rise to an incessant and deep-seated ache with a frequent desire to empty the bowel. Rectal spasm plays an important part in causing these sensations.

### Rectal Spasm; Proctalgia Fugax

Although rectal spasm usually has an organic lesion as its basis, it does occur as a functional disorder. Its aetiology is then the same as for colonic spasm in the irritable bowel syndrome.

Rectal spasm causes a deep-seated pelvic discomfort and a desire to evacuate the bowel. The rectum is tender, so dyspareunia is a common complaint and the findings on vaginal examination may mislead the observer into thinking that adnexal disease, cellulitis or retroversion is the cause of symptoms. The treatment of rectal spasm is the same as for the spastic colon of irritable bowel syndrome.

Proctalgia fugax is characterised by sudden, and sometimes severe, rectal pain that occurs at irregular intervals by day or by night. It can be easily diagnosed clinically. Treatment may be difficult. Some patients may respond to the oral administration of nifedipine. Topical application of nitroglycerine has also been found to be useful.

### Vaginal Neuralgia; Vaginal Myalgia

For want of better names, these are devised to describe a complaint of deep-seated pain, usually unilateral and paravaginal, which is persistent for years. It is not relieved by sitting or lying. The pain is often at the level of the insertions of the pubovaginalis and puborectalis

muscles, and these may appear to be in spasm. However, despite the fullest investigation and prolonged observation, the majority have no organic cause in the spine or in the pelvic organs. The patient is usually of introspective and tense disposition, and sometimes has cancerophobia. It is therefore tempting to conclude that the syndrome has a psychogenic basis. This is supported by the fact that the pain, of which the patient complains bitterly, rarely keeps her awake.

The only treatment of any value consists in the elimination of background factors, placebos and reassurance. Pudendal nerve block sometimes gives temporary relief, but such an effect is probably psychological because, on repetition, the treatment is usually unsuccessful.

# CHAPTER 56

## Preoperative and Postoperative Management: Postoperative Complications

Preoperative Management	900	Postoperative Examination	907
Postoperative Management	903	Postoperative Complications	907

Although minor procedures usually cause little disturbance, most major operations impose nervous and physical stresses which result in metabolic and chemical changes in the body tissues and fluids. Many of these are brought about by 'stress' alterations in the functions of the adrenal cortex but other mechanisms, some not fully explained, are also involved. Increased adrenal cortical activity is manifested by a rise in the excretion of 17-ketosteroids, and by a fall in the eosinophil count (indicative of increased production of hydrocortisone) for 1 or 2 weeks after operation.

### Fluid and Electrolytes

Water constitutes approximately 50 to 55 per cent of the body weight of the average woman. Two-thirds of this water is contained in the intracellular compartment. One-third is contained in the extracellular compartment, of which one-fourth is contained in plasma, and the remaining three-fourths is in the interstitium.

Osmolarity, or tonicity, is a property derived from the number of particles in a solution. Sodium and chloride are the primary electrolytes contributing to the osmolarity of the extracellular compartment. Potassium and, to a lesser extent, magnesium and phosphate are the major intracellular electrolytes. Water flows freely between the intracellular and the extracellular spaces to maintain osmotic neutrality throughout the body. Any shifts in osmolarity in any fluid spaces within the body are accompanied by corresponding shifts in free water from spaces of lower to higher osmolarity, thus maintaining equilibrium.

The average adult daily fluid maintenance requirement is approximately 30 ml/kg per day, or 2,000 to 3,000 ml/day. This is offset partially by insensible losses of 1,200 ml/day, which includes losses from the lungs (600 ml), skin (400 ml), and gastrointestinal tract (200 ml). Urinary output from the kidney will provide the remainder of the fluid loss, and this output will vary depending on total body intake of water and sodium. Both the lung and the kidney play integral roles in the maintenance of normal extracellular pH via retention or excretion of carbon dioxide and bicarbonate. Under conditions of alkalosis, minute ventilation decreases and renal excretion of bicarbonate increases to restore the normal ratio of bicarbonate to carbonic acid. The opposite occurs with acidosis. Ultimately, the kidney plays the most important role in fluid and electrolyte balance through excretion and retention of water and solute.

The main changes which immediately follow surgical procedures are as follows:

- Loss of blood and surface evaporation from exposed tissues during the operation reduce the volume of circulating fluid. This is gradually made good by water taken from the extracellular space but, in the meantime, haemoconcentration and vasoconstriction maintain blood pressure and conserve the blood supply to the brain and heart. The number of blood corpuscles is subsequently restored to normal by increased activity on the part of the bone marrow.

A further loss of fluid from the circulation occurs by way of exudates into damaged tissues and from wounds during the early postoperative period.

- The volume of urine excreted is at first reduced, so the amount of extracellular fluid is kept constant or increased. A phase of diuresis follows 3-7 days after operation. In the meantime, the reduced urinary output is not to be interpreted as being due to an inadequate intake and as an indication for administering more fluids.
- Breakdown of tissue protein results in an increased excretion of urea, ammonia and amino acids, and this, unless counteracted by a high intake, can cause a lowering of the plasma protein level. The excretion of nitrogen returns to normal, and the tissue proteins are restored, 1-2 weeks after operation.
- Sodium and chloride are retained within the body because of increased adrenal cortical activity and decreased excretion by the kidneys. Salt excretion returns to normal along with the diuresis after a few days. Unless sodium and chloride are being lost by other channels (for example as a result of vomiting), saline is rarely required in the early postoperative phase. This is true even though the blood level of sodium is low because this finding is accounted for by a shift from the extracellular to the intracellular compartment.
- Depletion of the potassium content of the tissues is caused by an increased excretion of potassium by the kidneys for a few days postoperatively; a loss of potassium-rich intestinal secretions by way of vomiting, diarrhoea and gastric suction; and the breakdown of tissue proteins. The blood level of potassium may not reveal this deficiency to the full. It tends to be kept at a constant level and can remain within normal limits no matter whether cellular potassium is being depleted or replenished. Muscle

activity is very sensitive to potassium concentration in the tissues so one of the best methods to assess the latter is to study electrocardiographs, taken daily if required.

These and other changes are essentially protective and represent the normal response of the body to injury. The extent to which they occur after operation depends on the severity of the procedure, on its nature and on the ability of the patients' organs to respond. The capacity of the adrenal cortex to react to stress is all-important and women with adrenal insufficiency (such as occurs in Sheehan's syndrome or after corticosteroid therapy) can die as a result of a minor operation, or even of anaesthesia.

The bodily reactions to surgery become pathological when they are exaggerated, inhibited or modified by factors such as the following:

- Excessive blood loss before, during or after operation which is not immediately replaced
- Artificial overloading of the patient with fluid and salt
- Starvation before and after operation
- Vomiting and diarrhoea (including purgation) before and after operation
- Operations affecting renal and intestinal function
- Prolonged shock affecting the functions of endocrine and other organs
- Depression of haemopoiesis by disease or drugs.

Fortunately, most gynaecological surgery is relatively simple and does not disturb the alimentary and renal tracts. Moreover, it is usually carried out on women whose general health and capacity to react to stress are good. So metabolic and electrolyte disturbances rarely give rise to serious problems for the gynaecologist, unless the case is complicated or mishandled.

## PREOPERATIVE MANAGEMENT

### Preoperative Counselling

Personal exchange of information between physician and patient is essential before surgery. An informed written consent is to be taken after explaining to the patient the diagnosis, procedure, its benefits, risks, expected outcome and alternative treatments. The only exception to this may be in times of medical emergencies or, sometimes in the case of minors. In all cases the physician must have a sound knowledge of the law of the land

with regard to medical practice. Offering the patient a second opinion is wise in case of any doubt regarding diagnosis or management. If the patient refuses therapy, an informed refusal should be documented.

### Routine Investigation

Except in the case of minor procedures which can be carried out as out-patient procedures or necessitate only a short in-patient stay, most women are best admitted to hospital at least one day before operation. This not only permits thorough review of their case but enables them to get accustomed to their surroundings and to the staff who will care for them. The patient can also get acquainted with the physiotherapist and practice exercises which will be required of her afterwards. However, an unnecessarily long stay in hospital before operation is to be avoided. It is psychologically undesirable and, by enforcing inactivity, increases the risk of postoperative phlebothrombosis.

Assessment of the general health by ordinary clinical methods is essential in all cases, examination of the blood pressure, heart, lungs and urine being particularly important. The haemoglobin level and blood group should always be determined. Other tests such as blood sugar, platelet count, bleeding and clotting time are desirable. An electrocardiogram and routine radiological examination of the heart and lungs should also be carried out.

Many genital diseases disturb bladder function and are complicated by urinary tract infection. Full examination of the urine and estimation of blood urea are therefore necessary in all cases of prolapse, as well as in circumstances when there is good reason to suspect renal incompetence. Estimation of plasma electrolytes, proteins and liver function tests are desirable before extensive procedures such as radical operations for malignant disease. In selected cases, intravenous urography is indicated, especially if dissection near the ureters is envisaged. One of the reasons for this is the frequency of congenital anomalies; it may save the surgeon from looking for a ureter which is not present or from cutting one of two ureters on the same side.

Before any patient is subjected to anaesthesia or surgery it is wise to ask her specifically about the taking of corticosteroids in any form during the previous 2 years — such a history may indicate a need for boosting doses before and after operation; the taking of tranquillizers or other drugs which are incompatible with certain

anaesthetic agents; and the previous occurrence of general or local reactions to antibiotics, antiseptics or other medication.

Unless the urgency of the condition dictates otherwise, the patient should come to operation in as fit a condition as possible. This means correcting or combating any ill health, and especially anaemia, revealed by the above investigations. If there is a real likelihood of transfusion becoming necessary, cross-matched blood should be available at the start of the operation.

The almost routine infusion of fluid replacement, which anaesthetists are prone to give, may have merit in helping the patients to recover. Blood replacement is, however, quite unnecessary for the straightforward hysterectomy or other operation carried out on a relatively fit woman. The risk of transmission of blood-borne infections such as hepatitis and HIV has led many centres to practice autotransfusion. A healthy woman can donate one unit of her own blood preoperatively which is then set aside for her and transfused intraoperatively, if required.

### Surgery and Menstruation

Many gynaecologists prefer not to operate when a menstrual period is in progress. It is argued that the pelvic tissues are more vascular at this time, that a high vaginal pH makes infection more likely, and that endometrial debris may become implanted in vaginal and perineal incisions to cause endometriosis. These arguments do not withstand critical inquiry: the tissues are more vascular premenstrually than intramenstrually; the raised pH is caused by the presence of blood alone and follows any vaginal operation at any time; endometrium spilled during menstruation, when it is relatively inactive, is less likely to become implanted than is endometrium at any other stage in the cycle.

*There is no contraindication to operating during menstruation* except when tubal testing, hysteroscopy, or a similar procedure which involves the risk of intravasation of gas or fluid, is contemplated.

### Prophylactic Antibiotics

The prophylactic use of antibiotics is recommended when the expected incidence of infection is in excess of 10 per cent. Gynaecological procedures which carry a significant risk of infection include vaginal hysterectomy

tomy, abdominal hysterectomy, pelvic abscess drainage, radical surgery for gynaecological malignancies and selected cases of termination of pregnancy. Routine prophylaxis is desirable in all cases of vaginal hysterectomy. It may not always be necessary in the case of abdominal hysterectomy but is certainly desirable in high-risk patients, e.g. those from a poor socioeconomic status, prolonged procedure (more than 2 hours), presence of malignancy, combination of surgical procedures.

Antibiotics are selected according to the flora expected in the hospital and at that particular site. In gynaecological practice these are usually coliforms, streptococci, *Fusobacterium* and *Bacteroides*. Drugs selected for prophylaxis are generally older agents which would not ordinarily be used to treat established infection; which have a broad spectrum of action; which are cost-effective; and which have a low risk of complications. The first- and second-generation cephalosporins are the most commonly used, along with metronidazole, as they act against Gram-positive, Gram-negative and anaerobic organisms. Most classes of penicillins, tetracyclines, sulphonamides and anaerobic drugs have been effective as prophylactic antibiotics but none has been found to be superior to the first-generation cephalosporins.

The antibiotic is administered sufficiently in advance for adequate concentrations to be present in the wound area when the incision is given and, in the case of hysterectomy, when the vaginal cuff is opened. The drug remains effective for 3-4 hours. Depending on the agent selected, 1-3 doses are required, i.e. coverage for the first 24 hours. If surgery is prolonged and blood loss is significant, a second intraoperative dose may be required especially if an antibiotic with a short half-life is used. For termination of pregnancy, a single oral dose of doxycycline 100-200 mg at bedtime on the evening prior to surgery may be sufficient prophylaxis.

There is a very thin line between prophylaxis and early treatment. Overuse of prophylactic antibiotics leads to the development of resistance. Cross-infection is also more likely; there is an increased incidence of superinfection due to *Pseudomonas* and *Candida* with cephalosporins. For optimal results, prophylactic antibiotics should be used as an adjunct to, and not in lieu of, sound surgical principles which include careful handling of tissues, meticulous haemostasis, avoidance of unnecessary tissue pedicles in ligatures, minimal use of suture material and adequate drainage.

### Preparation of the Bowel

The alimentary tract should be disturbed as little as possible. The evening meal before surgery should be light and easily digestible. Thereafter, the patient remains in the fasting state. For most gynaecological operations, all that is necessary is to make sure that the lower bowel is empty; this can be achieved by an enema or a stimulating suppository, such as one containing 10 mg bisacodyl given 6-12 hours before the operation.

In the case of operations involving the lower bowel such as the repair of a complete perineal tear or rectovaginal fistula, or if bowel injury is a possibility as in cases of severe endometriosis or advanced ovarian cancer, more vigorous and complete bowel preparation is required. The patient is advised to take a low-residue diet for 3-4 days before surgery and only clear fluids for 1-2 days preoperatively. Oral gut lavage solution containing polyethylene glycol, sodium chloride, potassium chloride and sodium bicarbonate is ingested at a rate of 1.5 L/hour until the diarrhoeal effluent is clear. Usually about 4 litres of fluid are required but the concomitant use of bisacodyl reduces the requirement to 2 litres.

Rarely, in the case of inadvertent bowel injury with an unprepared bowel, intraoperative irrigation of the bowel with Hartmann's solution can be done through a 14 F Foley catheter inserted through a pursestring suture into the colon or rectum.

Antibiotics are generally used in addition to the mechanical methods described above for complete bowel preparation. Oral neomycin, alone or in combination with erythromycin reduces the gut flora; the addition of metronidazole is required for the elimination of anaerobes. Neomycin has now been replaced by ciprofloxacin. Oral antibiotics have the disadvantage of promoting antibiotic resistance and superinfection with staphylococci and yeasts. Systemic antibiotic therapy overcomes this disadvantage. Various combinations include metronidazole with ciprofloxacin, ceftriaxone or gentamicin.

### Preparation of the Vagina

Although the attempt must be made, it is difficult if not impossible to sterilise the vagina with its irregular surface of rugae. Fortunately, organisms normally found within it are non-pathogenic or of low virulence. When it comes within the field of any operation, the vagina is prepared



in the operating room after the patient is anaesthetised. This is done by swabbing out any discharge, washing with gauze or cotton wool pledgets soaked in antiseptic solution, and thereafter by painting it with povidone-iodine. One of the most efficient vaginal antiseptics is 'Bonney's blue' — equal parts of crystal violet and brilliant green to make a 1.0 per cent solution in 50 per cent alcohol — but it stains everything with which it comes in contact. Some gynaecologists argue that this should be used because the colour permits identification of the vagina during total hysterectomy. If they need this help they should not be doing this operation. Some gynaecologists regularly operate without any form of antiseptic treatment of the vagina. Certainly, if total hysterectomy becomes unexpectedly necessary when the vagina has not been previously prepared, the surgeon need not worry about subsequent infection. Obvious infection should, of course, be treated preoperatively.

### Preparation of the Bladder

The bladder should, for reasons of safety and surgical access, always be empty at the time of a pelvic operation when performed by the abdominal route. But for vaginal procedures such as curettage, cervical biopsy, vaginal hysterectomy and repair of prolapse, catheterisation is quite unnecessary. It is enough for the patient to void voluntarily a short time before anaesthesia is induced. If some urine remains in the bladder it is of no consequence; it helps rather than hinders identification of the bladder during dissection, and offers it protection from injury. The need for catheterisation should be judged in each case by the surgeon and the catheter passed when the patient is anaesthetised.

If by chance the bladder is full at laparotomy it is perfectly safe to suck out the contents with a syringe attached to a needle passed directly through the bladder wall.

### Preparation of the Abdomen

Shaving of the abdomen and vulva are not essential but if required can be done preoperatively in the ward, or at the time of anaesthesia. Excess pubic hair can be trimmed with scissors and this is often more comfortable for the patient.

The abdomen is prepared by scrubbing for 5 minutes with povidone-iodine solution. The entire area from the rib cage to the mid-thigh and laterally up to the anterior

axillary line must be cleaned. Special attention should be paid to cleaning the umbilicus with a sponge on a holder or a Q-tip applicator.

### Universal Precautions

All patients may not have been screened for HIV, hepatitis B and other blood-borne pathogens and it is safer that the entire surgical team observe universal precautions, treating *all* patients' blood and other body fluids as potentially infective. All members of the team should be vaccinated against hepatitis B infection.

Recommendations for universal precautions include the following:

- The routine use of gloves when handling blood and body fluids (or items soiled with these), mucous membranes or broken skin
- Wearing double gloves while performing surgery
- Wearing a gown or plastic apron and gum boots if splashing of blood or other fluids is anticipated
- Wearing masks and eye protection if splashing or aerosolisation is expected
- Special care in handling and disposing of needles, blades and other sharp objects
- Prompt and thorough washing if accidental contamination occurs
- Relieving personnel with exudative skin lesions from patient care till treated.

In addition, emergency resuscitation devices should be available to minimise the need for mouth-to-mouth resuscitation.

## POSTOPERATIVE MANAGEMENT

### General

On return from the operating room to the recovery ward the patient is put to bed and covered with blankets. The bed should not be warmed with hot water bottles or electric blankets either before or after the patient's arrival. Warmth does no good, and may do harm if a condition of shock is present. Moreover, no matter how much care is taken, artificial methods of heat carry the risk of burns. Until she recovers consciousness, the patient should never be left unattended and should be laid flat and well over on her side to reduce the risk of inhalation of vomit and mucus. Thereafter, she should be encouraged to move freely in bed and to adopt any posture which she finds most comfortable, unless there are instructions to

the contrary, as in certain fistula repair and vulvar operations.

Deep breathing and simple arm, leg and foot exercises are commenced on the first day after operation. They should be carried out every hour when the patient is awake. Routine postoperative exercises reduce the incidence of fatal embolism. It is now established that it is advantageous to encourage ambulation as soon as possible. This is true for practically all types of gynaecological operations, including repair of the vagina and perineum although exceptions may have to be made when continuous gastric, intestinal or bladder drainage is employed. Early ambulation involves no risk of disruption of wounds in any site, even when the only buried suture material is thin catgut. It has the merits of reducing postoperative chest, bladder and alimentary tract complications, of avoiding muscle wasting, and of ensuring rapid physical and mental recovery from the operation. Besides raising morale, it contributes to the patient's comfort in many ways, by soon freeing her from the need for bed pans and from dependence on others for all her minor wants. Early ambulation also lowers the incidence of thrombosis and embolism in those clinics where a physiotherapist is not available to see that exercises are performed in bed; but in those where postoperative exercises are conscientiously performed its value in this respect is not established.

Ambulation must be early if it is to be valuable. The usual plan is to allow the patient to sit on the edge of the bed, then stand and take a few steps on the first day; to walk round the bed on the second; and thereafter to venture and walk at her will. Unfortunately, early ambulation as often practised is not *ambulation*. Having risen from bed, the woman sits in a chair, takes a few steps and sits again. Many hospitals are so planned that there is nowhere for her to walk. Sitting with flexed legs impedes the circulation of the lower legs more than any other posture. To obtain the best results from the standpoint of preventing thromboembolism, the patient should be either walking or in bed, *not sitting*.

The time of discharge from hospital depends on many factors such as the type of surgical procedure, home conditions and the amount of domestic help available. In some places it is influenced by shortage of hospital beds or cost.

After minor surgery the patient can be discharged in a few hours or days. In the case of biopsy or diathermy coagulation of the cervix she must be warned of the

possibility of secondary haemorrhage and told to report to the hospital if it occurs.

Ideally, after a major abdominal or vaginal operation it is wise to keep the patient under observation in hospital for 3-5 days until she is fit and active. There is always a risk of thromboembolic complications in the first week and secondary haemorrhage up to 15 days post-operatively; she must be warned of these and explained the steps to be taken in such an eventuality.

The rising costs of hospital care have led to a situation in many countries where, even for major surgery, the patient is admitted on the morning of the surgery and may be discharged on the same or the next day. This practice is followed not only for endoscopic procedures but also for vaginal hysterectomy. Excellent support systems are required if such practices are to be successfully implemented. Patients must receive clear verbal and written instructions, a homecare support team must be functional and ambulance and flying squads should be available to rush the patient to hospital if any untoward complication ensues.

### Analgesics and Hypnotics

While the operation site is painful, as it usually is for 2-5 days, analgesics should be given freely, not 'as a favour', and the patient should know that they are available whenever *she* thinks that she needs them. Pain is a symptom which can always be relieved and there is no excuse for not doing so. Any respiratory depressant effect which some analgesics may have is of little consequence compared with their beneficial action. There is nothing more conducive to restricting respiratory excursion than a sore abdomen. Morphine in some form, or pethidine, are efficient but can cause nausea and vomiting. These side-effects can be prevented by the simultaneous administration of chlorpromazine or prochlorperazine; this also potentiates the sedation. The use of patient-controlled analgesia (PCA) perhaps improves the quality of analgesia. Usually the total dose of the agent is not exceeded by this method, but in-built controls are provided to prevent toxicity due to overdosage.

The use of opioids or fentanyl in epidural anaesthesia provides effective pain relief and should be considered in all patients with large abdominal incisions. A combination of opioids and local anaesthetics provides a synergistic effect. Here also, patient-controlled top-up administration improves analgesia. Long-acting

anaesthetic agents injected into the incision are of doubtful value.

Once the acute pain subsides, injectable diclofenac and tramadol are suitable analgesics. After a few days milder analgesics such as paracetamol are generally sufficient.

In addition to analgesics a hypnotic is usually desirable at night initially. Sometimes this may have to be continued even when the physical discomforts of the operation have passed. There is always a reaction to the mental stress of an operation, and the relatively inactive life in the strange atmosphere of the hospital is not conducive to sleep. There is little need to fear a drug habit; patients give up the hypnotic as soon as they are convalescent.

### Epigastric and Shoulder Pain

One special type of pain commonly seen after abdominal operations is situated in the epigastrium, or referred to the shoulder tip, and it can be troublesome for 2 or 3 days. When injury to the brachial plexus has been excluded, it can be assumed that the pain is due either to a pneumoperitoneum or to the soiling of the diaphragm with blood and other fluids. The relationship of the shoulder pain to posture permits a distinction. In either case the cure is spontaneous.

### Fluid Replacement; Diet

If the blood loss during an operation is excessive, it should be replaced at the time or immediately afterwards. Nevertheless, many blood transfusions are given unnecessarily and without appreciation of the potential risk. One unit of blood is hardly ever required for haemorrhage; it needs at least 1-2 litres or none at all! After operation, care is necessary not to overload the circulation with any sort of fluid.

In addition to the basal requirements, intraoperative losses, third-space losses and losses through sweat, bowel secretion or effects of anaesthetics on effective blood volume need replacement. If a central venous line is in place it provides an accurate guide to replacement.

The maintenance fluid requirement can be calculated in the following ways: the body surface area is multiplied by 1000 to get the daily fluid requirement in millilitres; or, by the second method, a 60 kg patient needs 100 ml/hour. For every additional kilogram body weight, 1 ml/hour is added.

Crystalloid solutions are used for perioperative fluid replacement. Ringer's lactate is preferred to normal saline, but in cases where there is hyponatraemia or in the presence of brain injury, normal saline is preferred.

Colloid solutions are used only when large amounts of crystalloids have already been infused, blood pressure is difficult to maintain, or in patients with low colloid oncotic pressure, e.g. in patients with carcinoma of the ovary with massive ascites. Albumin and starch are the most commonly used. Albumin, although a blood product, is free from infectious agents because of heat treatment which is a part of the process of preparation. Dextran was popular earlier but it causes problems in cross-matching of blood. Hetastarch is a synthetic colloidal agent which is also free from infection but can affect the kidney and decrease coagulation so it needs to be used with caution. Packed cells are used when the haemoglobin level is less than 10 g/dl.

Most patients complain of a dry mouth or thirst during the first 24-48 hours after operation. This is due to the preoperative drugs used, by the anaesthetic, by insensible fluid loss from the lungs and skin, and sometimes by vomiting. Unless there is clear evidence of dehydration, thirst does not call for intravenous infusions and, moreover, the patient should be prevented from drinking large quantities of fluid. Frequent small sips and mouth washes are permissible but large quantities tend to cause intestinal distension and vomiting.

Provided the operation has not involved the intestine, the patient should be encouraged to eat a few sweet biscuits or a finger of dry toast within 24 hours of operation. Thereafter, and despite the fact that anorexia is likely for 4 or 5 days, the diet is built up gradually but quickly; the sooner it is back to normal the better. Foods containing protein and potassium are particularly required.

Total parenteral nutrition (TPN) is occasionally required in patients with cancer or impaired oral intake and bowel function. Any patient who cannot eat for more than a week should be put on TPN, and this decision should be made sooner rather than later. A peripheral or central access is used. TPN provides all the essential and trace element components of the diet but may vary depending on the presence of other metabolic and endocrine conditions. The patient with acute blood loss needs replacement with appropriate isotonic fluid or blood or both. There are a wide range of plasma volume

expanders, including albumin, dextran, and hetastarch solutions, which contain large-molecular-weight particles (>50,000 molecular weight). These particles are slow to exit the intravascular space, and about one-half of the particles remain after 24 hours. These solutions are expensive, however, and for most cases, simple replacement with 0.9 normal saline or lactated Ringer's solution will suffice. One-third of the volume of lactated Ringer's solution or normal saline typically will remain in the intravascular space, and the remainder goes to the interstitium.

### Bowel Action

The intestinal function is usually disturbed to some extent by the operation, and it should be made a rule not to disturb it further by irritating laxatives and enemas. With a limited intake of food for a few days after operation there is little residue and, in any case, it does not matter whether the bowel remains unmoved for 3-4 days.

To avoid inspissation of faeces, and provided the continuity of the intestine was not disturbed at operation, 15 ml of liquid paraffin or a preparation of mucilage may be given twice or thrice daily, commencing as soon as postoperative nausea and vomiting have subsided. This, with increasing activity of the patient, is usually followed by spontaneous evacuation within a few days. A simple enema or a mildly stimulating suppository may be given if no action occurs at the end of a week, and is occasionally indicated by the second or third day if intestinal distension or colic are troublesome. *No stimulating laxative should be given until a bowel action has already occurred.*

After perineorrhaphy, while it was customary to delay bowel action if possible until the fourth or fifth day, it is of no consequence if it occurs earlier.

After the repair of a complete perineal tear many aim to delay bowel action for 7-8 days by giving a low-residue diet. At the end of that time an enema should never be given because the nozzle can damage the operation site. A suppository together with mild a laxative should be enough.

### Attention to Bladder—Urinary Retention

For the reasons, and by the mechanisms, urinary retention is common after any pelvic operation. Because of this many surgeons make it a rule to insert a catheter

at the end of all except minor procedures and to leave it in place for 24 hours. The advantage is that it allows measurement of urinary output but it hinders movement, and almost invariably results in some urethritis and cystitis, so when the standard of supervision in the ward is high it can be omitted because 50-75 per cent of women will void spontaneously. If, however, nursing supervision is inadequate then it is safer always to drain the bladder. Retention rarely follows vaginal operations if posterior colpoperineorrhaphy is omitted. There are certain procedures such as radical hysterectomy, operations for urinary stress incontinence and the repair of a fistula in which an indwelling catheter is essential for many days.

When a catheter is omitted, careful watch is kept and the output of urine measured. During the first 12 hours, and especially if the operation is a major one, very little urine may be secreted. But if none has been voided or if the woman's discomfort or percussion of the lower abdomen reveals a distended bladder, a self-retaining catheter should be passed and allowed to drain continuously for 48 hours or more; keeping the bladder empty allows it to recover tone.

After the initial catheterisation, and with encouragement and relief of pain, the woman will usually void naturally.

When urine is being passed regularly it can never be assumed that all is well, and ultrasound examination for residual urine should be made whenever it is uncertain that voiding is complete. The woman who, in the days following operation, passes small amounts of urine at very frequent intervals is not suffering from cystitis. She nearly always has overflow incontinence or incomplete emptying of the bladder. This is most likely to happen when initial retention is overlooked or not treated by prompt catheterisation. The neglect of retention and incomplete emptying is a serious matter which sometimes leads to gangrenous cystitis.

Residual urine is a nidus for infection and the overdistended bladder, damaged possibly by ischaemia, is ill equipped to put up a good defence. The bladder which is emptied regularly has little difficulty in coping with bacterial invaders.

Initial postoperative retention in a nervous woman can sometimes be overcome by simple measures such as encouragement, running a tap, use of a commode instead of a bed pan, and by ensuring privacy. However, too much reliance should not be placed on these, nor on

cholinergic drugs. It is better to catheterise too soon than too late, and too often than too seldom.

When catheterisation becomes necessary, the risk of causing cystitis is minimised by:

- The use of a disposable, pre-sterilised plastic or latex catheter
- The employment of a 'no touch' technique rather than 'scrubbing up' for insertion
- The application of chlorhexidine jelly to the urethra before inserting the catheter
- When an indwelling catheter is employed it should drain into a *closed* sterile container which is fitted with a 'no return' valve
- While the prophylactic use of antibiotics during continuous drainage is often advocated, it is better to reserve these agents for selective use if infection occurs.

### POSTOPERATIVE EXAMINATION

Full examination of the patient is essential prior to her discharge from hospital. This includes the inspection of wounds to assess their state of healing. All unabsorbable sutures should have been removed (a nylon or silk suture in the perineum is easily overlooked), or in the event of an early discharge, a clear plan for removal of these sutures must be given to the patient. Vaginal examination is required if there is any suspicion of collection of blood or pus in the pelvis.

It is desirable for all patients to be seen 6-8 weeks after operation to ensure that progress is normal and that healing is complete. This is instructive to the surgeon as well as satisfying to the patient who often finds a few questions which she has previously omitted to ask. Any light adhesions between anterior and posterior vaginal walls after colporrhaphy can be broken down (Fig. 56.1).

Instructions to the patient should include advice about return to work. Women vary in the rapidity with which they recover. After a minor operation such as curettage, the patient requires 2-7 days' convalescence at home before returning to work outside the house. After major abdominal and vaginal operations, light household duties can be resumed in 3-4 weeks but heavy physical effort and work outside the home should be avoided for 6-8 weeks. At that time, recovery is relatively complete but most women find that it is 3-6 months before they feel entirely well, mentally and physically, after a major operation.



**Fig. 56.1:** Adhesions between the anterior and posterior walls of the vagina following colporrhaphy. Because these were not recognized and broken down 2-3 weeks after operation they became so strong as to form a septum which required division under anaesthesia

One question which is uppermost in their minds, but which women hesitate to ask, concerns resumption of coitus. They should therefore be counselled, and this varies with the type of operation. Most will find that they have little sexual desire until they are physically fit and this is in itself a good guide. Whenever the operation has involved the vaginal walls or cervix, coitus should be banned for 6-8 weeks; preferably until after the first follow-up visit. Premature attempts at coitus can cause breakdown of incisions and, if painful, may result in vaginismus with permanent dyspareunia. On the other hand, the avoidance of coitus for too long after vaginal operations may allow senile contracture to occur to such an extent as to produce permanent apareunia or dyspareunia.

### POSTOPERATIVE COMPLICATIONS

#### Shock

A condition of shock may develop during or following major operations, especially if they are difficult and long lasting. The word shock in this context does not have a precise meaning, but can be defined as a severe circu-

latory disturbance which may progress to circulatory failure and death of the patient. The mechanical factors concerned are: the central venous pressure on the right side of the heart; cardiac efficiency; the resistance in the pulmonary circuit; and peripheral vascular resistance (arteriolar spasm).

The clinical picture of shock is variable. The causes of shock can broadly be categorised as hypovolaemic, intravascular volume depletion, cardiogenic, extracardiac and mixed.

The blood pressure is usually low but may be normal or high. The pulse can be rapid or slow, full or thready. The skin can be warm or cold, moist or dry, pale, cyanosed or pink. Two types are sometimes described as '*warm hypotension*' and '*cold hypotension*'; the former usually precedes the latter.

In warm hypotension, the pulse volume is good, the skin is warm and pink. The underlying cause is often a state of infection. In cold hypotension, the cardiac output is poor and the peripheral vessels are in spasm. The pulse volume is poor and the patient is pale and cold. This is seen classically in conditions of blood loss or in advanced septic shock.

## Causes

### *Hypovolaemic*

Loss of volume may be due to loss of blood or loss of other body fluids.

*Loss of Blood:* The commonest cause of shock and collapse during and immediately after operations is loss of blood; and the effect of this is accentuated if the anaesthesia results in anoxia.

Unless steps are taken to measure it, the amount of bleeding that occurs during an operation is generally underestimated by the surgeon. Haemorrhage, revealed or concealed, may also occur after the operation, from a vessel insecurely ligatured.

The clinical presentation varies depending on the rate and amount of blood loss.

*Loss of fluids:* This may be the result of evaporation from exposed tissues, vomiting, diarrhoea or rapid drainage of ascitic fluid.

### *Intravascular Volume Depletion*

In these cases, the total body water is normal or marginally decreased but there is a shift of fluid from

the intravascular compartment leading to volume depletion.

*Sepsis:* Peritonitis arising in the early postoperative period often does not cause the classical symptoms and signs. There may be distension and vomiting but sometimes the picture is only that of warm hypotension. If the operation disturbs a focus of sepsis, evacuation of incomplete abortion for example, a sudden bacteraemia can produce a most alarming and serious state of shock.

*Adrenal insufficiency:* Adrenal atrophy, possibly associated with previous corticosteroid therapy or with an incompetent anterior pituitary gland can also cause shock.

*Drug sensitivity:* Allergic reactions to antibiotics and drugs can simulate shock and be fatal.

*Posture:* Prolonged maintenance of the lithotomy or Trendelenburg position causes loss of vasomotor tone in the leg vessels so, when the patient is later put in a horizontal position, the volume of blood available for circulation outside the legs is considerably reduced.

*Cardiogenic:* Myocardial infarction, cardiomyopathies and dysrhythmias can all result in decreased cardiac output which further results in circulatory collapse.

*Extracardiac:* Extracardiac lesions that have an obstructive effect include pulmonary embolism, constrictive pericarditis, severe pulmonary hypertension, cardiac tamponade and coarctation of the aorta. Here a vicious cycle of progressively decreasing filling and decreasing cardiac output develops, leading to myocardial insufficiency and collapse.

### *Mixed Aetiology*

*Neurogenic:* Sometimes immediate postoperative collapse occurs, presumably caused by an autonomic nerve reflex, in patients who have stimulation of the genital tract without adequate anaesthesia. This has been seen in some patients in whom a pack was inserted in the uterus. Removal of the pack results in rapid recovery. A similar situation may occur in some patients undergoing dilatation and curettage under local anaesthesia and mild sedation.

## Treatment

### *Position*

Lay the patient flat and elevate the foot of the bed to maintain the circulation to the brain.

### *Warmth*

Cover with blankets but do *not* apply heat. Pallor and coldness of the skin are manifestations of a protective mechanism whereby the peripheral circulation is reduced to maintain the blood supply to the vital organs. Warmth counteracts this and also involves serious risk of skin burns.

### *Oxygen*

Oxygen is administered through a mask or nasal catheter.

### *Blood Transfusions*

Any blood lost must be replaced but, if there is delay in obtaining cross-matched blood, a blood substitute ('plasma expander') can be given. The need to transfuse and the amount of fluid required is best estimated by central venous pressure recordings. If the means for this are not available it is better to judge by the patient's general condition than by her blood pressure or pulse rate. Blood component therapy suited to the condition is desirable, rather than using whole blood.

### *Inotropic Agents and Vasopressors*

Vasoactive agents are not indicated in the management of hypovolaemic shock. Dopamine is used if the mean arterial pressure is less than 60 mmHg. In doses less than 3 mg/kg/min it produces vasodilation by increasing systemic perfusion, but at moderate doses of up to 10 mg/kg/min it has  $\beta_1$ -adrenergic inotropic effects which increase cardiac output. Dobutamine has  $\beta_1$ - and  $\beta_2$ -adrenergic effects and is the preferred agent in cardiogenic shock. Epinephrine and norepinephrine increase blood pressure but their vasoconstrictor effect can precipitate myocardial ischaemia, so they need to be used with caution.

### *Antibiotics*

For the patient exhibiting the warm hypotension syndrome it is wise to give large doses of antibiotics intravenously, on the assumption that the underlying cause is infection or septicaemia.

### *Glucocorticoids*

Glucocorticoids can be life-saving in anaphylactic shock but have no role in treating other types of shock.

### *Morphine*

This is used only in patients with cardiogenic shock. As soon as restorative measures are instituted and the patient's general condition permits, she must be examined to exclude the possibility of haemorrhage from an insecurely ligated vessel at the site of operation. Once this is excluded, other causes are looked for and treated according to their nature.

## Haemorrhage

### *Vaginal Site*

Haemorrhage from the vaginal walls is commonly seen after operations such as colporrhaphy and vaginal hysterectomy, from the cervix after amputation, cone biopsy, cauterisation or trachelorrhaphy, and from the vaginal vault after abdominal hysterectomy.

### *Primary*

This type of haemorrhage is apparent within the first 24 hours after operation and is the result of failure to control one or more large vessels, often an artery. It can be so severe and persistent as to threaten the patient's life, and should *not* be treated by packing the vagina. Effectual tamponade is impossible without anaesthetising the patient and is nearly always followed by infection and breakdown of incisions. It should therefore be made a rule to treat primary haemorrhage of any degree by taking the woman back to the operating room and by suturing the bleeding area, even if this means opening and reclosing perineorrhaphy incisions to obtain access. Vacillation rarely pays; it is worrying to the patient and attendants, and means that ultimately the resuturing has to be carried out on an anaemic woman or be accompanied by blood transfusion.

In the case of bleeding from the vaginal vault after abdominal hysterectomy, the bleeding point can often be sutured by a vaginal approach.

### *Secondary*

Secondary haemorrhage usually occurs between the eighth and fourteenth days or earlier after the first 24 hours after operation and is associated with the separation of a slough. It is nearly always the result of low-grade infection in the wound so, whatever local measures are adopted, systemic treatment with antibiotics is also indicated. The amount of bleeding may be

small and the only treatment then necessary is recumbency, antibiotics and sedation. When the bleeding is more severe, the vagina can be packed tightly with an 8-10 cm wide gauze. This is left in place for 24-48 hours and, if bleeding recurs after its removal, another pack is inserted. Packing is done under general anaesthesia after carefully observing vault.

Suturing for *secondary* bleeding is usually unnecessary and is always difficult. The bleeding is rarely localised to one point and is more in the nature of an ooze; the tissues are infected and friable and sutures cut out unless they are deeply placed and mattress in type.

### Intrapelvic Site

Haemorrhage occurring after an abdominal operation is nearly always the result of a slipped ligature on the ovarian or uterine vessels, more often the former. It requires laparotomy to secure the bleeding point. An ovarian vessel usually retracts retroperitoneally so the haemorrhage is not within the peritoneal cavity and is difficult both to diagnose and to control. A bleeding uterine vessel causes so much extravasation into the cellular tissues that it can be impossible to find; in this case the anterior branch of the internal iliac artery has to be tied. Remedies like intra-arterial embolisation are seldom helpful and usually result in wastage of time.

Haemorrhage from the cavity of the uterus after myomectomy or hysterotomy can occasionally be controlled by packing the uterus under general anaesthesia.

### Pyrexia

Pyrexia of slight or moderate degree during the first 48 hours after an operation is common and sometimes called 'reactionary'. It is probably caused by absorption of the products of tissue damage and blood clots and does not require treatment. Operations which inevitably involve some oozing and haematoma formation, separation of adhesions and myomectomy for example, are nearly always followed by a low-grade pyrexia which may persist for 7-10 days. This is never an indication for administering antibiotics. Nor is the occurrence of a slight rise in temperature 7-14 days after abdominal or vaginal total hysterectomy. This is nearly always caused by a small vaginal vault haematoma with or without low-grade secondary infection. The resulting pyrexia settles when the haematoma discharges itself vaginally, as it nearly always does.

More serious rises in temperature, especially when accompanied by tachycardia, systemic upset or localising symptoms call for investigation of their cause. Treatment is then planned according to the findings. The most common causes are: urinary tract infection; infection in an abdominal wound, usually preceded by haematoma formation; peritonitis, pelvic or generalised; and pulmonary complications including embolism.

### Retention of urine

*See above.*

### Anuria

Anuria is not common after pelvic operations but has to be excluded when the patient appears to be suffering from retention. Failure to secure urine on catheterisation is of serious concern and, if renal disease can be excluded, suggests obstruction of both ureters. Although the ureters are vulnerable during many operations, it is exceptional for both to be involved. Anuria may result from ligation of a one and only ureter but bilateral ureteric obstruction has been reported following anterior colporrhaphy when the dissection and suturing has extended widely in front of the cervix. In such a case the ureters are obstructed by distortion and oedema rather than by actual ligation and if the colporrhaphy is immediately undone, urine begins to flow again. This simple and effective measure is always the best treatment for this complication. Nephrostomy or ureterostomy are sometimes advised but are unnecessary.

Whenever a patient complains of one-sided ureteric pain after a gynaecological operation, the possibility of the ureter on that side being obstructed should be excluded by urography.

### Incontinence of urine

#### *Through The Urethra*

The cause of urethral incontinence after operation is either retention of urine with overflow or a failure of the sphincter mechanism. The latter is not uncommon after a self-retaining catheter has been in place for a long time; it is usually temporary and self-curative.

#### *Through The Vagina*

Escape of urine through the vagina is always due to a fistula between the urinary and genital tracts. If the



leakage occurs immediately after operation, its cause is a direct injury to the bladder or ureter. If it appears 7-14 days later, the cause is ischaemic necrosis of tissues. If the case is handled promptly and well, either type of bladder fistula may heal spontaneously.

### Cystitis; urethritis; pyelonephritis

Cystitis is the commonest complication of pelvic surgery. There may be an associated urethritis but this is not easy to establish. The infection sometimes extends to cause pyelitis and pyelonephritis.

#### Causes

##### *Bacteriology*

The commonest organism found is *Escherichia coli* but *Klebsiella*, *Streptococcus faecalis*, *Proteus vulgaris*, and *Pseudomonas* are also prevalent. Seven per cent of all apparently healthy women carry these and other organisms in the form of bacteriuria.

##### *Mechanism*

- Residual urine in the bladder resulting from retention or incomplete emptying is an underlying aetiological factor. Stasis in the ureters associated with the hydronephrosis of prolapse favours pyelitis.
- Catheterisation.

#### Clinical Features

The disease ordinarily makes itself manifest by dysuria, frequency and urgency, commencing 5-10 days after operation. Pyrexia is common, especially if the ureters are involved. The diagnosis is confirmed by the finding of pus cells, a significant number of bacteria, and sometimes red blood corpuscles, in the urine. The organisms present should be identified and tested for sensitivity to antibiotics.

#### Treatment

- Make sure that the patient is emptying the bladder completely; if she is not, catheterise.
- Give large quantities of water or bland fluids, at least than 2-3 litres daily.
- Render the urine alkaline (pH 7.5) by administering large doses (2 g) of potassium citrate or sodium bicarbonate 2-4 hourly. Alkalinisation of the urine enhances the antibacterial activity of penicillins,

erythromycin and aminoglycosides. This is especially useful in infection caused by *E. coli*, *Proteus* and some other coliforms, some diphtheroids and *Staph. albus* give rise to alkaline urine. Acidification is ineffective in such cases.

- Antibiotics; the choice depends on the results of bacteriological examination. Pending the result of sensitivity tests, it is generally best to administer one of the quinolones as these offer the broadest spectrum of coverage.

#### Results

It is usually not difficult to eradicate the infection. Moreover, the cure is almost always complete and permanent. Follow-up studies show that, in women, infection rarely persists in chronic form after an episode of postoperative cystitis. If it does, there is some underlying anatomical or other defect in the urinary tract.

#### Postoperative Vomiting

Nausea and vomiting are common after any operation but usually subside within 12-24 hours.

#### Causes

##### *Anaesthesia*

Vomiting is seen more often after general anaesthesia.

##### *Operation and Pain*

Abdominal operations are more likely than vaginal to be followed by vomiting. The more extensive the procedure and the greater the handling of the bowel, the more likely the vomiting.

##### *Drugs*

Morphine and other opiates are very prone to cause sickness and should not be used for preoperative medication. The use of morphine postoperatively should always be suspected as the cause of vomiting which is more persistent than usual. Pethidine is less likely to cause this problem but is by no means blameless.

##### *Inherent Tendency*

Certain individuals are more prone to vomit than others. The person who suffers travel sickness is generally also subject to postanaesthetic vomiting.

### Radiotherapy

This causes nausea and vomiting by its effects on the gastrointestinal mucosa.

When vomiting persists for longer than 24 hours, and when it does not respond to simple measures, one of the following more serious causes should be suspected.

- Acidosis resulting from starvation and vomiting
- Electrolyte disturbance (*see* Ileus' below)
- Dilatation of the stomach. The stomach muscle is quiescent for at least 48 hours after abdominal surgery and can become distended with fluid and gas. The last is mostly air swallowed by the patient.
- Paralytic ileus
- Intestinal obstruction.

### Treatment

Postoperative vomiting is best treated by the administration of ondansetron, a highly selective 5-HT<sub>3</sub> receptor antagonist which acts on 5-HT receptors in the chemoreceptor trigger zone. At induction, 4 mg is administered IV or IM and 4-8 mg repeated after 8 hours or as required. Ranitidine 50 mg IV 8-hourly can be administered to patients at risk for vomiting and stress ulcers.

The treatment of persistent vomiting is described below under 'Ileus' and 'Intestinal obstruction'.

### Intestinal Distension and Colic

One of the most distressing features of any abdominal operation, and of certain vaginal operations as well, is the tendency to intestinal distension which occurs in some degree approximately 48 hours after operation. This can be replaced or accompanied by intestinal cramps. These symptoms probably reflect returned activity of the large bowel which, unlike the small intestine, is generally quiescent for 2 or more days after operation. They generally subside within 24 hours of their onset and with the passage of flatus.

Postoperative distension or colic is less likely if the surgeon is gentle in handling viscera and pays scrupulous attention to haemostasis and asepsis; drinking of large quantities of fluid after operation is discouraged and the eating of solid food is encouraged; and early ambulation is encouraged.

Distension causing more than minimal discomfort should be treated with analgesics and antispasmodics administered parenterally every 4-6 hours. A rectal tube can be passed and sometimes a simple enema helps. On

no account should a laxative or other bowel stimulant be given. A heat cradle over the abdomen for a few hours may give relief.

Sometimes the distension fails to settle spontaneously or in response to simple measures, the abdomen becomes larger and tympanitic, and vomiting ensues. The *late* onset of vomiting or its persistence from the time of operation is always ominous. In association with distension it betokens mechanical intestinal obstruction or paralysis of the bowel (*ileus*) and, unless handled promptly and efficiently, can prove fatal.

### Paralytic Ileus

#### Clinical Features

Distension and vomiting are the leading features of ileus, the vomit being profuse and foul. When the vomiting becomes faeculent it usually betokens mechanical intestinal obstruction. Intestinal colic is absent and auscultation fails to reveal the bowel sounds characteristic of peristalsis. The tense abdomen causes generalised discomfort and embarrasses respiration, increasing the risk of chest infection. The patient who suffers from ileus may be of anxious disposition and, if she is not, the condition itself arouses her anxiety; this makes matters worse.

The vomiting leads to acidosis, dehydration and depletion of potassium and sodium. Hypokalaemia has a paralysing effect on the gut and causes further distension. The facies become hippocratic, the pulse rate rises as the blood pressure falls, but death often occurs suddenly from myocardial failure associated with potassium deficiency.

### Causes

#### Shock and Injury to Intestine

These, occasioned by prolonged operation, rough handling and traction on autonomic nerves were formerly regarded as the main causal agents but are now accepted as being unimportant. The *main known aetiological factors* are as follows.

#### Haemoperitoneum

Because of this, ileus is more common after myomectomy (where haemostasis is difficult) and after wide separation of adhesions, such as may be required during operations for pelvic infection and endometriosis.

### Peritonitis

This may be primary or may follow haemoperitoneum, but it can also be the end result of intestinal obstruction. The occurrence of ileus in the presence of peritonitis is considered by some to be a natural defence mechanism; it discourages spread of the infection.

### Swallowed air

This makes the distension worse.

### Treatment

A paralysed bowel should be left at rest and the patient treated with analgesics and sedatives. With the onset of vomiting a fine tube is passed down to the stomach or into the small intestine. Continuous or intermittent suction is then applied. Feeding is by intravenous drip infusion, starting with 5 per cent dextrose saline but varying the solution according to the blood chemistry, care being taken not to overload the patient with sodium.

Records are kept of the intravenous fluid intake, and of the output by both tube and kidneys, and an attempt made to achieve a proper balance. The blood electrolyte levels are studied before and during treatment. Hypokalaemia is corrected by adding potassium chloride to the intravenous infusion fluid or giving it by way of the gastric tube.

Bearing in mind the likelihood of underlying peritonitis, antibiotics are given intramuscularly or in the infusion and, as the days pass, a watch is kept for evidence of a collection of blood or pus in the pelvis or abdomen.

The above regimen is only discontinued when satisfactory bowel sounds return, when it is clear from the gastric suction records that fluid is passing along the alimentary tract, and when flatus is passed. The sensation of hunger is the best indication that normal bowel motility has returned.

### Intestinal Obstruction

If intestinal function does not return to normal within a few days, or if the patient complains of attacks of colic unaccompanied by bowel action and exaggerated peristaltic waves can be heard through a stethoscope, it is practically certain that the intestine is mechanically obstructed. Adhesions which cause this can form within 2-3 days of operation.

Straight radiological examination of the abdomen with the patient in sitting and horizontal positions is of considerable assistance in diagnosis. Many of these patients will respond to conservative measures such as restarting of intravenous fluids, nil per orally and continuous nasogastric suction. If the patient does not respond to these measures, the abdomen must be reopened. It is less dangerous to carry out laparotomy unnecessarily than to overlook mechanical obstruction. In any case it provides an opportunity to release adhesions and any collection of pus or blood.

### Peritonitis

#### Types

General peritonitis makes itself manifest 2-3 days after operation and presents the clinical features described under 'Ileus'. Pyrexia, tenderness in areas other than around the incision, rebound tenderness and hyperaesthesia may be present but *the onset of the disease is often insidious and without the classical signs*. Distension and vomiting are the prominent features; muscle rigidity is slight or absent. The onset of shock may be the first warning.

After gynaecological operation, peritonitis is more often limited to the pelvis where an abscess may form. This is shown by the patient failing to recover as she should, and by pyrexia, tachycardia and leucocytosis. The localising symptoms, however, are nearly all rectal—pain on defaecation, diarrhoea, frequent motions and colic. A rectal examination or ultrasound should be done to exclude a collection of blood or pus in the pelvis before diarrhoea, occurring a few days after operation is blamed on the hospital food. It is remarkable that general peritonitis paralyses the bowel, whereas pelvic peritonitis tends to stimulate it. The diarrhoea, however, is often spurious in that the fluid is excessive mucus from the hyperaemic bowel rather than faeces.

#### Causes

A healthy peritoneum can ordinarily cope with bacterial invaders, provided the invasion is arrested. The development of peritonitis after operation may mean contamination with organisms of unusual virulence but *is more often secondary to haemoperitoneum*; occasionally it results from an unsealed opening in a viscus. The presence of a swab or instrument left behind at the time of operation should also be considered.

### Treatment

This is primarily conservative and is the same as for ileus, with particular emphasis on antibiotic therapy. Surgery is indicated when an abscess forms or when there is a cause for peritonitis which can be removed. A pelvic abscess is generally best drained through the vagina.

### Wound Infection; Wound Disruption

*Closed* wounds do not become infected in the ward and can be left completely uncovered after 3 hours from the time of operation when fibrin seals the wound. This practice avoids much postoperative discomfort and reactions from adhesive strapping; it is economical and permits ready inspection of the incision.

Infection and breakdown of wounds are, in most cases, the results of an error in surgical techniques at the time of the operation, although blame is often attached to a particular batch of suture material or some other factor outside the surgeon's control. Of all the agents which come into contact with the tissues during operation, the suture material as supplied by reputable firms is the least likely to be contaminated. The fault lies more often in the method of scrubbing up, of application of gloves and gowns, of sterilising and handling of instruments, of preparation of the skin, and in the operative technique.

Asepsis is always relative and it is inevitable that some organisms enter the operation field by one means or another. Their types and numbers can, however, be controlled by care; their survival and growth can be prevented by not damaging tissues and by not leaving dead spaces and collections of blood on which they thrive. The basis of nearly all wound breakdowns is haematoma formation and this can be avoided by conscientious haemostasis or, if oozing cannot be arrested, by drainage. It is more important to drain a bleeding than an infected operation field.

### Causes

#### Errors in Surgical Technique

- Breakdown in aseptic technique
- Contaminated dust and air in the operating room
- Operating in the presence of active infection
- Careless and inaccurate suturing
- Inadequate haemostasis
- The use of unabsorbable non-irritant suture material in the fascia makes dehiscence of abdominal wounds

less likely. It is important to concentrate on haemostasis and technique in closing abdominal and vaginal incisions.

- Incisions in the upper abdomen are more likely to disrupt than those in the lower. In the lower abdomen a vertical incision is more liable to serious breakdown than is the Pfannenstiel incision. The latter involves a greater likelihood of small haematoma formation, but I have never seen it break down to involve fascia and peritoneum. Except for removing large or ovarian tumours or undertaking radical surgery, it is always preferable for abdominal gynaecological procedures.

#### Inability to Sterilize the Operation Field

- Infection, peritonitis for example, may already be present and be the indication for operation.
- The vagina is practically impossible to sterilise (as discussed earlier) but this is of little importance.

#### Defects in the Healing Properties of Tissues

- *General debility*: Complete disruption of the wound is not uncommon after laparotomy for cancer and occurs without evidence of infection or haematoma. There appears to be a failure in the healing processes, yet it is extraordinary that when such a wound is immediately resutured after freshening the edges it nearly always unites without further difficulty. The explanation of this is that the original suturing sets in motion a repair reaction in the tissues of which they take advantage the second time.
- *Deficiency states*: Protein and vitamin C deficiencies are especially important.
- *An obese abdominal wall*: Leaving a drain inside markedly improves the chances of primary healing.
- Old age and senile tissues
- Diabetes mellitus.

#### Associated Postoperative Complications

- Haemoperitoneum
- Ileus causing abdominal distension and vomiting
- Severe coughing.

### Diagnosis

The diagnosis of wound infection and breakdown can be obvious but the early recognition of dehiscence of abdominal incisions is not always easy. This is because

it usually occurs from within outwards, that is, the peritoneal layer breaks first. Unexplained abdominal discomfort with malaise, distension and colic can be the first warnings, while *the escape of a volume of lightly bloodstained fluid*, too large to represent the serum from a haematoma in the abdominal wall, is pathognomonic of a 'burst abdomen'. Such fluid can only come from the peritoneal cavity.

### Treatment

Rupture of an abdominal incision through to the peritoneum calls for immediate resuture of the *whole* incision, even though part of it appears secure. Accurate apposition in layers is inadvisable, even if it is possible, and the usual method is to place strong unabsorbable sutures through all layers. The results are surprisingly good in that recurrent breakdown is rare. Incisional hernias, however, follow in 10 per cent of cases.

Superficial breakdown and infection of abdominal wounds requires antiseptic applications, and possibly treatment with antibiotics according to bacterial sensitivity.

Vaginal and perineal incisions often give way a little but, generally, it is only the surface layer which is involved and there is rarely any need to worry that a prolapse might recur. Treatment consists of daily Sitz baths and sometimes antiseptic douches, but the cure is mainly dependent on time and tissue resistance. The ultimate result is invariably good functionally, and often anatomically as well.

### Suppurative Thrombophlebitis

Thrombosis of the pelvic veins secondary to infection and sometimes resulting in pyaemia is an unusual complication of surgery.

### Superficial Venous Thrombosis

Thrombosis of the superficial veins of the leg shows itself within 2 or 3 days of operation, often within 24 hours, and is the result of circulatory stasis caused by immobility before, during and immediately after, operation. Varicosities are an important predisposing factor. The vein and surrounding cellular tissue become painful, hard and tender; the overlying skin is reddened.

This condition is not serious for it hardly ever gives rise to embolism. It is treated by active movement of the leg within the limits allowed by the pain. Local

applications soothe the patient's mind rather than the local disease; cure occurs spontaneously. Treatment with anticoagulants is unnecessary and unwise, unless there is evidence that the thrombosis is spreading and threatening to involve the deep veins.

### Deep Venous Thrombosis

#### *Incidence and Site*

Deep vein thrombosis occurs with equal frequency after any type of operation. Indeed, patients in medical as well as surgical wards of a hospital are prone to develop phlebothrombosis. It occurs in men as well as women and is not explained by the latter taking oral contraceptives.

In those gynaecological units where the medical team is on the alert to prevent and diagnose the condition, not less than one per cent of patients develop *clinically evident* deep phlebothrombosis or pulmonary embolism, or both, *after* admission to hospital. These diseases complicate 3-5 per cent of major operations, irrespective of whether the abdominal or vaginal approach is employed. The figures may be higher in those units where reasonable prophylactic measures are not adopted. Hysterectomy and prolapse repair operations carry equal risk, but certain operations, notably radical vulvectomy and urethral sling operations, are particularly liable to be followed by thromboembolic episodes.

The above figures apply to thromboembolism that gives rise to symptoms and clinical signs of its presence. The use of sophisticated means for studying the venous circulation reveals evidence of some degree of *occult* thrombosis in the lower limbs following 30-60 per cent of *major* operations and in one-third of all hospital in-patients, medical or surgical. About 40 per cent of deaths following hysterectomy are due to pulmonary embolism.

Nevertheless, significant thrombosis found at autopsy has often given no sign of its presence during life. In some such cases it is probably only a terminal event.

There is always some degree of thrombosis in ligated veins and arteries at an operation site; haemostasis depends on this. It is difficult to say how far this has to extend before it is regarded as being beyond the normal reaction to injury. It is reported that asymptomatic pelvic vein thrombosis can be found following 2-4 per cent of hysterectomy operations. Mostly *it starts in the venous*

*plexuses in the soleus muscle of the calf.* From these it spreads upwards to affect the main venous trunks. Less common *primary* sites are the popliteal, anterior tibial, deep femoral and external iliac veins.

## Causes

### *Blood Stasis*

Risk factors for this include:

- Obesity, body weight over 80 kg
- Immobility before operation for more than 4 days; during and after operation
- Impairment of the venous return at the time of operation by flexion of the knees or thighs, as in prolonged vaginal or laparoscopic procedures
- Direct pressure on the popliteal veins by pillows or pads used to support the knees during and after operation
- Direct pressure by the operating table on the calves, the veins being even less protected when the muscles are paralysed by relaxant drugs
- Shallow breathing during the days following operation; this is most likely with a painful abdominal wound and abdominal distension
- Circulatory failure associated with shock
- Age over 45 years
- Compression of the left common iliac vein by the overlying artery; this normal anatomical feature explains why deep thrombosis is more often left-sided
- Gross varicose veins.

### *Hospital Life*

As noted above, all women entering hospital are at risk, even if an operation is not performed. This is because of limitation of physical activity; sitting in chairs rather than walking; and lying in bed on their backs.

### *Dehydration*

This results from vomiting, diarrhoea and haemorrhage.

### *Anaemia*

This results from disease and haemorrhage before, during or after operation, without adequate replacement.

### *Injury to the Vein Walls by Pressure or Anoxia*

This is caused by compression of the popliteal veins in the lithotomy position as noted above.

### *Blood Changes*

Although the modern trend is to attach blame for postoperative thrombosis on blood stasis during the operation, this mostly results in only minor asymptomatic degrees of thrombosis. It is the later extent of the thrombotic process in the leg, or at the operation site, which causes trouble and this does not usually become manifest until 7-14 days after operation. This development coincides with an increasing coagulability of the blood which reaches a maximum at 8-12 days. Changes in the blood are the most important of all factors in causing significant and dangerous thromboembolism and they include: a rise in the number of platelets; an increased adhesive property of platelets; and an increase in fibrinogen content. All these happenings are exaggerated when the operation is prolonged, difficult or complicated by infection, so these must also be reckoned as aetiological factors.

### *Pregnancy*

Pregnancy alone is characterised by alterations in the blood clotting factors and by slowing of the venous circulation. It therefore involves a risk of the spontaneous occurrence of thromboembolism. Labour is followed by all the changes which occur after an operation, so *clinically evident* puerperal thromboembolism complicates 1 in 300 deliveries. Any operation on a pregnant woman, or delivery by caesarean section, doubles this incidence.

### *Oestrogens and Progestogens*

The oestrogen-progestogen preparations used as contraceptives and in the treatment of endometriosis induce blood and circulatory changes similar to those of pregnancy. It may, therefore, be that women who have been on such therapy are at greater risk if subjected to surgery, but this is not proven. Oestrogens, especially natural oestrogens which a woman coming to surgery might be taking for climacteric symptoms, may not encourage venous thrombosis but, added to her age and potential immobility, the risk is greater. Also, women with deficiency of protein C, protein S and antithrombin III are at greater risk.

### *Constitutional*

Certain individuals and certain families seem especially prone to this disease. A past history of phlebothrombosis or embolism is an ominous portent.

### *Malignant Disease*

Advanced pelvic cancer often becomes complicated by deep venous phlebothrombosis in the legs and death from embolism is not uncommon. The aetiological factors concerned are: interference with the venous return by the growth itself; cachexia and anaemia; and physical immobility.

### **Clinical Features**

The first clinical evidence of deep venous thrombosis is usually pain, tenderness and stiffness or cramp in the back of the calf; this the patient tends to dismiss as a muscle ache caused by posture, inactivity or unaccustomed activity. It is wise, therefore, to apply Homan's test (dorsiflexion of the foot to put tension on the calf muscles causes pain if thrombosis is present) daily to all patients recovering from an operation. Those using sophisticated diagnostic methods say that Homan's sign is unreliable. This may be true for minor degrees of thrombosis in the lower leg but the test is certainly valuable for thrombosis of clinical significance. Patients should also be instructed to report *immediately* any discomfort in the leg and, if this is situated over any part of the course of the deep veins, it should always be regarded as a sign of thrombosis. Tenderness is present at the site of thrombosis (Moses' sign).

The first sign of deep thrombosis usually appears 7-14 days after operation but may be earlier in patients who have been confined to bed preoperatively. Any leg pain which is reported during the second postoperative week should be regarded as being due to phlebothrombosis until proved to the contrary. Low-grade pyrexia often accompanies or precedes other evidence of thrombosis. This is the effect and not the cause of the disease; the thrombosis is not due to phlebitis.

Within 2-4 days of the onset of pain, the foot and ankle, and sometimes the whole leg, begin to swell. Exceptionally, the first clinical evidence of phlebothrombosis is painless swelling of the leg. Otherwise it is a mistake to wait for the appearance of oedema before making a diagnosis and starting treatment. By the time the lower leg is swollen the venous system is extensively involved and permanent impairment of the circulation is the likely outcome.

It seems that to cause obvious enlargement of the leg the thrombosis must be as high as the ileofemoral junction. If it extends above this to the inferior vena cava, gross swelling of both legs results.

The typically swollen lower limb is traditionally called a 'white leg' or *phlegmasia alba dolens* although, initially at least, the skin often looks slightly cyanosed.

The much rarer condition of 'blue leg' or *phlegmasia cerulea dolens* is the result of total occlusion of the vein at a high level and associated obstruction of the artery by spasm or by pressure of the tense tissues. The consequence is cyanosis and ecchymoses as well as woody oedema and disappearance of the pulse at the ankle. A possible sequel to 'blue leg' is gangrene of the foot or leg. This condition can have a very acute onset and cause severe pain and even shock. It can develop post-operatively but its usual basis is advanced pelvic or abdominal malignant disease.

### *Investigations*

To confirm clinical phlebothrombosis and to detect occult disease, the following procedures are described.

- *Venography*: The dorsal veins of the foot are injected with a radio-opaque medium and its movement up the veins is studied with X-rays. A persisting filling defect must be seen in at least two films for diagnosis of thrombosis. Although it has been the 'gold standard', it involves hazards like allergic reactions and renal injury. About 5 per cent of patients may develop phlebitis. Other non-invasive tests are usually preferred nowadays. Venography may have a role in cases in which embolectomy is under consideration.
- The ultrasonic Doppler instrument can be applied over the main leg and groin veins to detect the flow of the blood. This is simple and reasonably efficient but it is not sensitive in detecting thrombosis in smaller veins, e.g. the soleal sinuses in the calf (accuracy less than 60%). It is also not effective as a screening test for higher risk groups. Duplex Doppler imaging which combines Doppler examination with real-time ultrasound is most accurate, allows direct visualisation of clots in the femoral system, assessment of venous collapsibility with the probe, is non-invasive and has replaced venography as the gold standard for the diagnosis of deep venous thrombosis.
- *Radioisotopes*:  $^{125}\text{I}$ -labelled fibrinogen is injected into the lower venous system and its progress up the leg is studied by scanning. The discovery of a hold-up is said to be one of the most reliable methods of diagnosis. However, 72 hours may be required for a

positive result. Moreover, it is unreliable in the upper thigh and pelvis because iodine excreted into the urinary bladder and the pelvic blood vessels generates 'noise'.

### *Impedance Plethysmography*

Impedance plethysmography is a non-invasive bedside technique which measures the change in electrical resistance in response to altered venous blood flow. It has a 95 per cent correlation with venography in the larger veins (external iliac, femoral and popliteal) but this falls to 50 per cent for smaller veins, e.g. in the calf and also does not detect thrombi in the internal iliac venous system.

### *Magnetic Resonance Imaging*

MRI can demonstrate venous clots. It has the advantage of being non-invasive but is expensive.

### *Other Methods*

Whole blood D-dimer assay and light reflection rheography (scatter of infrared light) have also been used, mainly in research protocols.

None of these procedures can be trusted to reveal thrombosis which does not actually obstruct the vein to some extent and even large thrombi in the iliofemoral segment do not always do so. Is it any wonder then that those who use them conclude that the only reliable clinical sign is oedema?

## Complications

The *immediate* fear is spread of the thrombosis to involve the large veins at a higher level. With or without this, the main danger is the occurrence of pulmonary embolism which can be lethal. Even when supervision and treatment are assiduous and prompt, clinically recognisable embolism can still occur but is then hardly ever fatal.

*Remote sequelae* are rarely seen if efficient anti-coagulant therapy is commenced within 12-24 hours of the first clinical evidence of thrombosis. This ordinarily results in complete cure without any damage to the veins.

Late diagnosis and neglect of phlebothrombosis can result in the following:

- Extension of the thrombotic process from the lower leg to involve the popliteal, femoral, and iliac veins, even the inferior vena cava

- Permanent occlusion of the main vein with consequent development of chronic oedema, superficial varicosities and gravitational ulcers
- Even if the main veins do not become obstructed or if they become recanalised, their valves are damaged so they function badly
- Intractable menorrhagia is a rare sequel but happens when the iliac vein is obstructed and a collateral circulation develops through the uterus (*see* Fig. 38.4).

## Treatment

### *Prevention*

Measures under this heading include the correction of anaemia and blood loss; the avoidance of pressure on the calf and popliteal fossa; careful surgical technique; early movement and ambulation (*not* angulation) after operation; routine breathing and other exercises before and after operations; the avoidance of the dorsal position and 'foot drop' in bed; the omission of restrictive dressings on the abdomen; and the avoidance of the steep Trendelenburg and Fowler positions. It is also suggested that women confined to bed or hospital should compress their legs (to hurry the venous return) by wearing elastic or thromboembolism-deterrent (TED) stockings routinely, but this cannot be very acceptable to most patients.

Special machines are designed to maintain a good venous circulation during, and for 24 hours after, major surgery. These include a motorised foot mover; leggings which are intermittently inflated by an electric pump; and means for automatic electrical stimulation of the calf muscles. Such measures have been shown to improve the venous return and to prevent stasis and perhaps their place is for cases in which the patient is known to be at special risk of developing thrombosis and in all major operations.

Low-risk patients, i.e. those who are young without any of the risk factors or those who have undergone only minor surgery can be advised early mobilisation and hydration.

Patients with any of the risk factors mentioned above are at moderate risk and should receive low-dose heparin 5000 units administered subcutaneously 2 hours preoperatively and repeated every 12 hours postoperatively for 5-7 days. At this dose, there is no significant change in clotting time and therefore no increase in intra- or postoperative bleeding. Low-dose heparin binds to



antithrombin III and inhibits the early stages of coagulation before the formation of thrombosis.

Low molecular weight (LMW) heparin, e.g. enoxaparin (20 mg/day) has been found to be nearly as effective as subcutaneous heparin in preventing thrombosis formation and is superior to dextran. Other LMW heparins are tinzaparin, dalteparin and reviparin.

Patients with three or more of the risk factors, those with a past or family history of thromboembolism, or those who undergo radical surgery for gynaecological cancer are high-risk patients. They should receive 5000 IU of heparin subcutaneously 8-hourly or low molecular weight heparin 40 mg/day beginning at least 12 hours before surgery and should also be advised to wear graduated compression stockings.

The use of low-dose heparin has been associated with thrombocytopenia and an increased incidence of lymphocyst formation. Infusion of a solution of 6 per cent dextran 70 (molecular weight 70 000) in saline, 1 litre over 6 to 8 hours, provides protection akin to heparin for 5 days. Dextran 40 needs to be given continuously at 20 ml/hour because it is cleared rapidly or, alternatively, 500 ml of dextran 40 may be administered over a period of 4 to 6 hours daily.

### General

As soon as thrombosis is diagnosed or suspected, the patient should be laid flat and the foot of the *bed* raised to speed the venous return from the legs. Once anticoagulant therapy is established, and as soon as pain allows, active movement of the legs is to be encouraged. Walking (not standing still or sitting) is permissible and desirable within 1-3 days, as pain, tenderness and oedema disappear. Anti-coagulants appear to relieve pain very quickly; the patient sometimes notices this within one hour of being given heparin intravenously.

### Anticoagulants

Immediately there is any evidence of deep venous thrombosis, treatment with anticoagulants is a matter of extreme urgency. *It cannot wait until next morning.* These drugs save life and prevent permanent disability. Only those who have seen thrombosis left untreated can appreciate how remarkable are the results of anticoagulant therapy.

If overdosage and consequent haematuria and haemorrhage from other sites are to be avoided, the

administration of most anticoagulants requires strict laboratory control; even this cannot eliminate the dangers completely. The only really safe procedure is to give heparin *intravenously and in divided doses*. We have used this for years without strict laboratory control and without any problems. At the same time complications occurred with all other anticoagulants, and even with heparin given by *continuous* intra-venous infusion.

Anticoagulants prevent the extension of thrombosis; it is the new and not the established thrombus which is potentially embolic. It is doubtful whether they ever clear a vein already obstructed; this explains why they must be employed early in the disease, while the clot is attached to the vessel wall and not filling the lumen, if the circulation is not to be permanently affected.

When anticoagulant therapy is discontinued suddenly, 'rebound hypercoagulability' of the blood may occur and result in a further episode of thrombosis or embolism. To avoid this, anticoagulants are given in full dosage while the clinical picture demands it (at least 7-10 days' treatment is required, no matter how satisfactory the patients' response is), followed by the administration of oral anticoagulants for at least 3 months.

### Heparin

Heparin is an antithromboplastin which acts by interfering with the conversion of prothrombin into thrombin; it may also interfere with the interaction of thrombin and fibrinogen. When given intravenously in a single dose, it is effective within minutes but its action gradually wanes during the course of 4 hours. It is this short-lived effect which, although a nuisance from the practical standpoint, makes heparin safe. Even if an overdose is given and some haemorrhage results, the situation corrects itself in a short time and can meanwhile be controlled easily by the antidote protamine sulphate, given in solution intravenously; 1 mg neutralizes 1000 IU heparin.

In theory the most efficient mode of administration is by continuous intravenous drip infusion, a 5000 unit bolus being followed by an infusion at the rate of 1000 units per hour. This technique has the disadvantage that it makes ambulation more difficult; it also requires constant expert supervision of the rate of the infusion, and repeated laboratory checks if overdosage and underdosage are to be avoided. Heparin therapy should be monitored by estimating the activated partial

thromboplastin time (APTT), four hours after such therapy is initiated. The aim is to maintain the APTT at 1.5-2.0 times the control value. If the APTT test is not available, clotting time is done; it should be maintained at not less than 12 minutes. Because of the difficulty in ensuring a constant delivery speed by day and night, an automatic delivery pump must be used or else *continuous* intravenous heparin therapy can be either ineffective or cause haemorrhage.

Transistorised visual and audio alarm systems for monitoring the rate of infusion offer a degree of security. But, unless such equipment is available, it is better and safer in practice to give heparin by repeated intravenous injection, commencing with 10 000 IU and thereafter giving 5000-8000 IU 4-hourly by day and night. This puts great demands on the services of the resident medical staff and, in practice, good results can be obtained by giving 10 000 IU at 6-8-hourly intervals. The treatment needs no control by blood studies because overdosage causes only temporary bleeding, the occurrence of which is a clear guide to reduce the next dose.

With this treatment, all evidence of early thrombosis usually disappears within 4 or 5 days, but heparin should be continued for a further 5 days during which time oral anticoagulant therapy is initiated, bringing the prothrombin time (PT) to 1.5 times the control value.

Heparin given intramuscularly is painful and dangerous and is very liable to cause a large haematoma at the site of the injection.

For pregnant women all anticoagulants except heparin are dangerous, for they cross the placenta to cause foetal malformation in the early weeks and haemorrhages in the child at a later stage.

The introduction of reliable low-dose subcutaneous heparin has changed the management of women at risk. It can be given twice daily and the woman can be trained to take the injections herself; the recommended dose is 5000 IU every 12 hours.

#### Oral Anticoagulants

Synthetic anticoagulants, e.g. warfarin sodium, phenindione and anisindione are given orally. They compete with vitamin K and interfere with the liver's synthesis of Factors V, VII, IX, X, thromboplastin components and prothrombin. Their effect on coagulation, being indirect, is delayed in onset and slow to disappear. Depending on the particular drug, full anticoagulant action is established in 12-36 hours, and

disappears completely in 36-72 hours from the start of medication. Thus all these preparations require a supplement of heparin to cover the first 1 or 2 days of treatment.

Their use also necessitates careful laboratory control with daily estimation of the PT.

Individual patients show wide variations in their response to the same dose. The effect of oral anti-coagulants is influenced by renal competence, liver function and the vitamin K content of the diet. The simultaneous administration of sedatives and tranquillisers, including phenobarbitone, may call for an increased dose; of salicylates and chlorpromazine, a decreased one.

Control of treatment is exacting; if overdosage occurs and haemorrhage commences from the operation site or elsewhere, it may be many hours before the situation can be controlled. The antidote is vitamin K<sub>1</sub> (not a vitamin K analogue) and this can be given intravenously in a dose of 20-25 mg, or orally in doses of 50-150 mg. It does not take effect for 6 hours; meanwhile, treatment is by repeated transfusions of fresh whole blood.

These agents are of particular benefit in cases of *suppurative* thrombophlebitis with recurrent embolism where it is difficult, if not impossible, to correct the situation by intravenous heparin alone.

The usual dose of warfarin sodium is 40 mg initially, followed by 30 mg on the next day and 5-15 mg daily thereafter. The comparable doses of phenindione are 200 mg, 100 mg and 50-100 mg daily thereafter. In all cases, however, the daily dose depends on the PT.

#### Ligation of Veins; Thrombectomy

Ligation of the common iliac vein or of the inferior vena cava is hardly ever necessary in cases of phlebothrombosis but may have a small place in the treatment of suppurative thrombophlebitis with pyaemia (*see* Chapter 22) or in some cases of pulmonary embolism (*see below*).

Removal of the thrombus from the femoral or iliac veins (*thrombectomy*), with or without ligation or plication of the vessel, is rarely required in gynaecological practice. Despite the enthusiasm of vascular surgeons there is usually no need for such drastic measures. Complete occlusion of the vessel leading to acute iliofemoral thrombosis and phlegmasia caerulea dolens may require surgical treatment, otherwise as many as 50 per cent cases can develop pulmonary embolism. Recurrent thrombosis and embolism, as well as permanent damage to, and occlusion of, the main veins are common after

thrombectomy (*see* Fig. 38.4), so anticoagulant therapy must be continued for 6-9 months.

### Thrombolysins

Once coagulation is arrested, the body is quite capable of dealing with all except the largest clots by the natural reactionary release of fibrinolysins. For massive thrombosis, however, streptokinase, an activator of plasminogen, has been tried in the hope of restoring the patency of a large vein. The dose is 600000 IU intravenously during the course of 30 minutes initially, followed by a continuous infusion of a 10 per cent solution aimed to offer a *maximum* of 100000 IU hourly for 3 days. The dose is gradually decreased over the next 4 days.

Strict laboratory control is essential and this is difficult as well as critical. The stated aim is to reduce the thrombin time to 2-4 times less than the original reading, or the clot lysis time from 24 to 4 hours.

The treatment carries the hazard of precipitating haemorrhages and the antidote is  $\epsilon$ -aminocaproic acid (EACA). The therapeutic value of thrombolysins is not established and they have little if any place in the management of thromboembolism as seen in gynaecological practice.

### Treatment of Residual Oedema

Major degrees of venous thrombosis may leave the affected leg oedematous; or oedema may appear on standing. The best treatment of this is to apply a well-fitting elastic stocking *after the patient has been at rest* to reduce the swelling to a minimum. The stocking is then worn continuously. With time, and with the establishment of a collateral circulation, the oedema usually gradually becomes less and the leg then gives little trouble. The imperfection of the venous drainage, however, may continue to show by slight premenstrual swelling of the leg.

### Pulmonary Embolism

In gynaecological units *recognisable* pulmonary embolism occurs once for every 300 operations of all kinds, much more frequently if only major surgery is considered. In 50 per cent of cases it is preceded or followed by clinical evidence of deep venous thrombosis in the leg; otherwise it presents without warning. Small embolic accidents are probably extremely common but, being silent, pass

unnoticed. Where preventive physiotherapy, and early treatment of deep venous thrombosis and of non-fatal embolism with anticoagulants are practised conscientiously, the incidence of *fatal* pulmonary embolism is reduced to 1 in 2500-5000 gynaecological operations, varying with the proportion of major to minor procedures. Following major surgery, the risk is approximately 1 in 1000 cases.

### Aetiology

The factors concerned in causing pulmonary embolism are the same as for deep venous phlebothrombosis (*see above*).

Pulmonary embolism is a recurrent disease; the woman who has one attack is liable to another within a few hours or days.

### Pathology

The clot which shifts to enter the pulmonary arteries is not one which is established and giving evidence of its presence in the veins of the legs. It is an unstable one, newly formed or a new extension of the original. For this reason embolism can occur before there is any sign of venous thrombosis.

Pulmonary infarction requires the lodgement of a *large* clot in one of the main branches of the pulmonary artery. This clot comes from the femoral or iliac vein in 70-80 per cent of cases, from the pelvic veins in 10-15 per cent.

To kill, it is necessary for the embolus to put out of action at least 50 per cent of all lung tissue (counting both lungs); this means that associated spasm of unblocked arteries plays an important role in fatal cases.

Small emboli do not cause infarction of *healthy* lungs, only of those already diseased or congested by cardiac failure.

A late sequel to the deposition of multiple and recurrent emboli can be pulmonary hypertension.

### Clinical Features

Pulmonary embolism, like deep venous thrombosis, most often manifests itself 7-14 days after operation, but can be earlier if the patient has spent some time in hospital before operation.

Massive embolism results in a dramatic picture in which the patient complains of sudden violent pain in the chest; this is followed by shock and sometimes by

death from ventricular fibrillation or cardiac arrest within a few minutes. Severe dyspnoea can be a leading symptom but generally follows initial non-fatal pain and collapse. It is then accompanied by tachycardia, cyanosis and congestion of the neck veins; the patient may become mentally confused or comatose.

Minor degrees of embolism with peripheral infarction presents by way of pain over one or other lung which quickly assumes the features of pleuritis, being made worse by deep breathing and by any movement of the chest wall. A cough develops and within a day or two the sputum is likely to be stained with blood. By that time, but not previously, there may be clinical signs of consolidation of the lung.

Pyrexia of varying degree is generally present and this may persist for a considerable time if a pleural effusion develops, as it not infrequently does. Pyrexia is the *result* and not the *cause* of the disease.

The sequence of events and the findings make it clear how easy it is to mistake minor and moderate degrees of pulmonary embolism for a painful muscular condition, and for pleuritis and pneumonia.

### Diagnostic Aids

The diagnosis is essentially a clinical one, particularly in the early stages of the disease, but ancillary aids described are:

- *Direct radiography*: This gives negative findings until consolidation of the lung or a pleural effusion develops a few days later.
- *Electrocardiography*: This generally reveals no abnormality and never unless at least one half of a lung is out of action.
- *Arterial blood gas assessment*: This shows evidence of hypoxaemia consequent to hypoperfusion.
- *Ventilation perfusion lung scanning*: This shows decreased perfusion within areas of adequate ventilation but very often the pictures are indeterminate.
- *Arteriography*: This has little place unless embolectomy is contemplated.

### Treatment

In gynaecological practice, unlike obstetrics, the first embolic incident is rarely fatal; hence the importance of its recognition by constant vigilance. Its occurrence is a sure sign that there is deep venous thrombosis somewhere in the body and that a second embolus, possibly a fatal one, is imminent.

If left untreated, 25-30 per cent of women who suffer one embolism will have a second, and one-fifth of these will die as a result. Prompt and efficient treatment of the first attack with anticoagulants usually prevents a recurrence.

### General

Massive embolism calls for resuscitation, the administration of oxygen intratracheally and the treatment of shock. External cardiac massage can be carried out for cardiac arrest. Morphine, atropine, antispasmodics and digitalis given intravenously may help. Any electrolyte imbalance must be corrected.

For the ordinary non-fatal case the main requirements are oxygen and relief of pain. When pyrexia develops, as it often does, antibiotics are *not* indicated; it settles of its own accord as the extravasated blood is absorbed. Nor should a pleural effusion be tapped; it will resolve spontaneously in the course of a few weeks.

Once the acute phase is under control and pain permits, active physiotherapy and ambulation are indicated.

### Anticoagulants

As soon as there is any evidence of embolism 20 000 IU of heparin should be injected intravenously; thereafter treatment with this agent is continued for 7-10 days, the technique being the same as that described for deep venous thrombosis in Chapter 56.

### Embolectomy

This is only indicated if the situation is desperate and the patient shows no response to resuscitative measures. Even then it is rarely practicable because death occurs within 2 hours in two-thirds of the fatal cases; this gives no time to prepare for and carry out the operation. The results are not good and, where cardiac massage has been required, they are very bad. One of the problems attending successful embolectomy is a recurrence of embolism; this prompts some surgeons to say that it must always be combined with thrombectomy.

### Thrombolysins

Pulmonary artery catheterisation with the administration of thrombolytic agents may be of help in patients with massive embolism.

### *Vena Cava Interruption*

Usually anticoagulant therapy will suffice to prevent the recurrence of thrombosis and embolism, while the pulmonary embolus is lysed by normal thrombolytic mechanisms. However, in some cases repeated embolisation from the pelvic veins or lower extremities may require clipping of the vena cava or placement of a vena cava umbrella or filter.

### **Pulmonary Complications**

Inhalation of anaesthesia involves the risk of postoperative bronchitis, bronchopneumonia, pulmonary collapse, inhalation asphyxia, and pneumonia. Prevention of these complications depends on good preoperative preparation and anaesthetic technique, and by encouraging the patient to perform deep-breathing exercises both before and after operation, as well as to stop smoking. Treatment consists of the administration of antibiotics and oxygen as required, together with breathing exercises and postural drainage. Incentive spirometry improves lung ventilation and prevents atelectasis. Suction bronchoscopy is occasionally necessary when an obstruction in a bronchus or one of its branches does not clear by itself.

The above conditions give evidence of their presence within the 2 or 3 days, in some cases hours, following operation. *Chest symptoms which commence after the first week are nearly always caused by embolism*, even if there is no evidence of venous thrombosis in the legs or pelvis. Failure to recognise this leads to many cases of minor embolism being overlooked, or being misdiagnosed as pleuritis and pneumonia.

### **Adult Respiratory Distress Syndrome (ARDS)**

ARDS is a relatively common pulmonary complication with a high mortality rate of about 50 per cent. It is characterised by progressive hypoxaemia resistant to oxygen therapy. Criteria for the diagnosis of ARDS include acute dyspnoea, tachypnoea (less than 20 breaths per minute); cyanosis; absence of left ventricular failure; diffuse pulmonary infiltrates on chest X-ray; PaO<sub>2</sub>, less than 50 mmHg; increased dead space ventilation; decreased total respiratory compliance.

ARDS has been associated with gastric aspiration, pneumonia, fat and amniotic fluid embolism and thoracic trauma. It is also seen in cases of eclampsia, disseminated intravascular coagulation, pancreatitis, infections, acute hepatic failure and massive transfusion.

Treatment is essentially supportive. Ventilatory support is the cornerstone of therapy. The use of steroids is controversial but they may be used in the first 48 hours. Careful fluid administration and broad-spectrum antibiotics in a sophisticated intensive care setting are vital to a successful outcome.

### **Vaginal Discharge After Operations**

#### *Healing of Vaginal Incisions By Secondary Intention*

Healing of the vaginal wall, and especially of the vaginal vault after total hysterectomy, is rarely completed by primary intention. As the wound granulates, it gives rise to a purulent and sometimes bloodstained discharge which is maximum 10-14 days after operation. It gradually decreases and disappears 3-6 weeks after operation. The patient worries over this discharge unless she is warned that it is likely to occur. Treatment is necessary if infection is present.

#### *Granulation Tissue*

In 20-30 per cent of cases of total hysterectomy, granulation tissue, often polypoidal, forms in the vaginal vault. Those who use chromic gut for closing the vagina can expect an incidence of 30-40 per cent. Meticulous attention to accurate apposition of the cut vaginal surfaces reduces the chance of this development.

The granulation tissue causes discharge, sometimes bloodstained, which can persist for months and even years after operation. The lesion is commonly mistaken for cancer or endometriosis but is easily distinguished microscopically. It is treated by avulsing the redundant tissue and by cauterising the area with silver nitrate; it then rarely recurs.

#### *Cellulitis*

Prolonged vaginal discharge following total hysterectomy, vaginal or abdominal, is sometimes the result of cellulitis and haematoma formation at the vault. This is diagnosed by feeling the tender indurated area. Antibiotics and anti-inflammatory agents such as chymotrypsin may help.

#### *Retained Foreign Body*

Whenever an unusually profuse and offensive discharge occurs after operation the possibility of an overlooked swab or tampon in the vagina should be investigated.

*Vaginitis*

*Trichomonas*, *Candida* or other kinds of vaginitis not infrequently date from an operation. It is explained by lowered resistance due to ill health; alteration in the vaginal flora by the administration of antibiotics; acquisition of the infection from another occupant of the ward; and inadequate sterilisation of gloves and instruments.

*Cervical Discharge*

After subtotal hysterectomy, the cervical stump is often responsible for leucorrhoea or for mucopurulent discharge at a later date. The best treatment is to excise the remainder of the cervix, preferably by the vaginal

route. This operation involves considerable risk of injury to the bladder which is usually lying partly on top of the stump. To avoid this during the vaginal approach, the peritoneal cavity should be opened *behind* the stump at an early stage in the operation.

*Urinary and Faecal Fistulas*

See Chapter 15.

*Rare Causes*

Infrequent causes of a discharge following operation include a fistula between the fallopian tube and the vaginal vault after hysterectomy, and endometriosis of the vagina.

# CHAPTER 57

## Nutrition in Women from Adolescence to Menopause

Nutrition Basics	925	Adolescents Nutrition	931
Carbohydrates	929	Obesity in Adolescents	932
Energy	930		

### INTRODUCTION

Nutrition is an input to and foundation for health and development. Better nutrition means stronger immune systems, less illness and better health. Healthy children learn better. Healthy people are stronger, more productive and more able to create opportunities to gradually break the cycles of both poverty and hunger in a sustainable way. Better nutrition is a prime entry point to ending poverty and a milestone to achieving better quality of life. There is vast magnitude of the many forms of nutritional deficiency, along with their associated mortality and morbidity in infants, young children and mothers. However, the world is also seeing a dramatic increase in other forms of malnutrition, characterised by obesity and the long-term implications of unbalanced dietary and lifestyle practices that result in chronic diseases such as cardiovascular disease, cancer and diabetes. Proper nutrition in women from childhood to menopause is very important not for the individual but for that matter for the whole family and for health of whole nation.

### NUTRITION BASICS

Life is nourished by food and the substances in food on which life depends are the nutrients. These provide the energy and building material for the countless substances that are essential to the growth and survival of living things. The nutrients include proteins, fats, carbohydrates, vitamins and minerals. The foods from where we get these nutrients are classified into five groups:

1. Cereals
2. Legumes (pulses)
3. Vegetables, fruits (Fig. 57.1)
4. Animal sources: milk and milk products and flesh foods (fish meat and poultry)
5. Nuts and oilseeds.

Carbohydrates, Proteins and fats are energy giving foods.

Vitamins and micronutrients are organic compounds essential for specific metabolic reactions and cannot be synthesised by human tissue cells from simple metabolites. Many act as coenzymes or as parts of enzymes responsible for promoting essential chemical reactions. Vitamin A and Niacin can be formed in the body if their precursors are supplied. Vitamin K, Biotin, folate and Vitamin B<sub>12</sub>



Fig. 57.1: Fruits and vegetables

are produced by microorganisms in the intestinal tract. Vitamin D is synthesised from a cholesterol precursor in the skin upon exposure to sunlight.

## Proteins

Proteins are needed for various tissues and cells of body:

1. They are important component of muscles and other proteins in the body in the form of enzymes and hormones and are needed for metabolic processes
2. They supply building material and make good for the loss that occurs due to wear and tear
3. As antibodies, proteins help to defend the body against infections.

Dietary proteins are broken down into amino acids and absorbed as such and used for various types of protein synthesis in body, for growth, for formation of enzymes, for wear and tear and hormones formation etc. If the diet does not contain enough carbohydrates and fats to provide for energy then proteins may be broken down to provide energy which is waste, so along with proteins in the diet, enough carbohydrates and fats are needed to provide energy.

1 gm of protein gives 4.2 Kcal of energy.

In normal diet 10-20 per cent of total energy should be from proteins.

## Sources of Proteins

All foods except sugar, oil and fats contain protein in varying degrees. Protein rich foods are animal proteins—meat, fish, eggs, milk and milk products, plant foods like pulses, oil seeds and nuts. Proteins from animal sources

are rich sources containing 20 per cent proteins and Soya bean is richest source containing 40 per cent proteins and cereals and millets are moderate sources containing 10 per cent protein. Rice contains only 7 per cent protein but its quality is better. Leafy vegetables, fruits, roots and tubers are poor sources as they contain only about 2 per cent protein. Defatted oil cakes are rich sources of proteins and contain 50-60 per cent of proteins. They were previously used for animal feed only but now they are available for human consumption by treating them by various methods and converting them into single chain proteins.

## Biological Values of Proteins

Amino acids are building blocks of proteins and there are 19 of them in proteins. Nine amino acids are designated as essential amino acids since they can't be synthesised in body. These nine essential amino acids are threonine, tryptophan, histidine, lysine, leucine, isoleucine, methionine, valine, phenylalanine and possibly arginine. Non-essential amino acids can be synthesised in the body. The best proteins are the ones which provide essential amino acids in the pattern very close to the tissue proteins. Egg protein and human milk protein satisfy these criteria and are classified as high quality protein which serve as reference point for other proteins. Cereal proteins are poor in amino acid lysine whereas pulses and oil seeds are rich in lysine but poor in sulphur containing amino acids so individually they are incomplete proteins. But to improve the quality of incomplete proteins they can be used in combinations so the deficiency of one can be overcome by other. Combination of cereals and pulses in the ratio of 5:1 is optimum combination. Protein value of cereal can also be improved by adding green leafy vegetables. However amino acid fortification in cereals of those taking mixed foods has only a limited value.

## Fats

### Background

Fat is a concentrated source of energy, it supplies per unit weight more than twice the energy furnished by either proteins or carbohydrates, 9 kcal/gm of fat. It also provides the mechanism for absorption of the fat-soluble vitamins A, D, E and K, and carries flavour. Fats retard stomach emptying.



### Sources of Fats

Fats can be visible fat i.e. derived from animal fats like butter, ghee which are solid fat or derived from vegetable fats like ground nut oil, coconut oil, safflower oil, til oil, flaxseed oil, canola and Soya bean oil which are liquid fats. Hydrogenated oil, vanaspati is solid fat and is popular in India.

Second is invisible fat, which is present in food items like cereals, pulses, oil seeds, milk, egg, meat etc. Dietary fat is predominantly triglycerides, which consist of three fatty acids and one glycerol unit. Fatty acids can be classified into saturated, monounsaturated, transfatty acids and polyunsaturated fatty acids.

### Saturated Fatty Acids

- Found in high amounts in animal products; also in high amounts in coconut and palm kernel oils.
- Because saturated fats are stable at high temperatures, they are often used for deep-frying. Deep-fried foods should be avoided, but if you have to fry foods at high temperatures, palm oil, which is mostly saturated, may be the best choice for its stability.
- Many saturated fats raise the risk of heart disease
- Saturated fatty acids predominate in animal fats and unsaturated fatty acids predominate in vegetable oils. Animal fats like ghee and butter contain Vit. A and D which are not present in vegetable oils. However these two vitamins can be added at a level of 700 IU and 50 IU respectively to hydrogenated fats i.e. vanaspathi which is derived from vegetable oil. Vegetable oil on the other hand contain Vit. E which protects the oil from oxidation.

### Trans Fatty Acids

Found mostly in foods made with hydrogenated or partially hydrogenated oils, including margarine, shortening, commercial frying fats, crackers, cookies, and other snacks. One must check the label. Butter and animal fat can also contain trans-fats from bacterial fermentation. The consensus among nutritional professionals is that large amounts of trans fats increase the risk of heart disease and many other diseases.

### Monounsaturated Fats (MUFA)

Also known as omega-9 fats, n-9, or oleic acid. They improve cholesterol levels and are abundant in olive oil, canola oil, high oleic sunflower oil, hazelnut oil, high-

oleic safflower oil, and almond oil. Olive may be the best oil for cooking at moderate temperatures. It is not as refined as other oils, making it a reliable source of vitamin E and possibly other healthy components.

Avocados and many nuts (almonds, cashews, filberts/hazelnuts, macadamias, peanuts, and pecans) are high in MUFA. Because nuts are high in nutrients and other protective compounds, one can benefit from eating them on a daily basis. In one study, eating nuts (including peanuts) 5 or more times per week reduced heart disease by about 50 per cent.

### Polyunsaturated Fats (PUFA)

There are two polyunsaturated fatty acids linoleic acid and  $\alpha$ -linolenic acids which can't be synthesised in the body and so have to be supplied in the food and they belong to families: omega-3s and omega-6s. Below is a list of the important ones. Individuals can use linoleic (omega-6) and  $\alpha$ -linolenic acid (omega-3) to make the long-chain polyunsaturated fatty acids (LCPUFA): arachidonic acid (AA), gamma linolenic acid (GLA), eicosapentanoic acid (EPA), docosahexaenoic acid (DHA) and docosapentanoic acid (DPA).

#### Omega-6s (n-6)

- LA - linoleic acid is the most prevalent omega-6 in plant foods and found in most vegetable oils (especially corn, sunflower, vegetable, soya, and safflower oils).
- Since most vegetarians get plenty of omega-6 fats they should limit these oils, especially in cooking.
- GLA - gamma linolenic acid is found in evening primrose oil, borage oil, black current oil, and breast milk. The body can make it from LA.
- DGLA - dihomo gamma linolenic acid is made from GLA. Some DGLA is converted into series 1 eicosanoids, which are considered good.
- AA - arachidonic acid is found in meat and peanut oil, and is also made from DGLA. AA is converted into series 2 and 4 eicosanoids, which are considered bad.

#### Omega-3s (n-3)

- ALA (aka LNA): Alpha-linolenic acid is found mainly in the oil of flaxseeds, hemp seeds, walnuts, rapeseed (canola oil), camelina (aka Gold of Pleasure), soybeans, and in some animal products. Also found

in very small amounts in leafy green vegetables and other plant foods. ALA reduces blood clotting, improves artery flexibility, and may also reduce heart arrhythmias. LNA shows a strong association with reduced cardiovascular mortality rates, including those from heart attack and stroke. Much of this may be due to its incorporation into cell membranes.

- EPA: Eicosapentaenoic acid is found mainly in fatty fish (from eating seaweed). Also in Irish moss and wakame, but the ratio of iodine to EPA is much too high to make these foods a recommended source. Some EPA is converted into series 3 eicosanoids (discussed below) which are considered neutral and can reduce inflammation, blood pressure, and cholesterol. The body can also make it from ALA or DHA (Fig. 57.2).
- DHA: Docosahexaenoic acid is found in seaweeds and fatty fish. DHA can be made from EPA. It is a major component of the gray matter of the brain, retina, testis, sperm, and cell membranes. Low levels of DHA have been associated with depression.

Long-chain polyunsaturated fatty acids (LCPUFAs) derived from linoleic (18:2n-6) and  $\alpha$ -linolenic (18:3n-3) acids are required for the normal development of the retina and central nervous system, but the extent to which they can be synthesised from the parent fatty acids is debated. Consuming LCPUFAs markedly increases their proportions in tissue lipids compared with their parent fatty acids. Thus, it has been argued that LCPUFAs must be supplied in the diet (Table 57.1). LCPUFAs are generally absent from plant foods, thus it is important to find out how essential fatty acid requirements are met by vegetarians. A developing foetus obtains LCPUFAs via selective uptake from its mother's plasma and LCPUFAs are present in the breast milk of vegetarians. There is no evidence that the capacity to synthesise

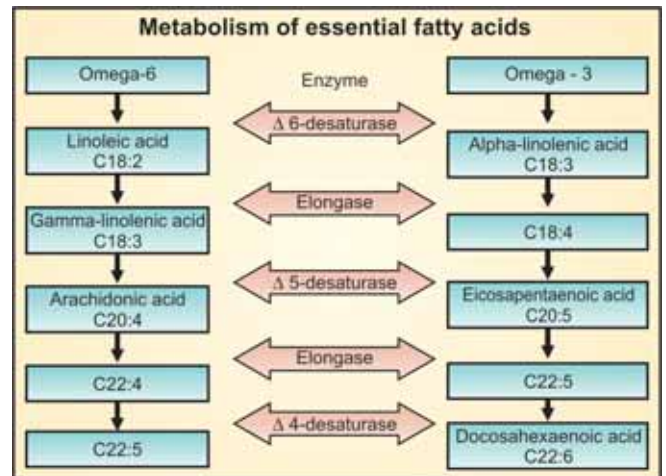


Fig. 57.2: Metabolism of essential fatty acids

LCPUFAs is limited in vegetarians. However, there are greater proportions of n-6 LCPUFAs and lower proportions of n-3 LCPUFAs in vegetarians compared with omnivores.

PUFA or polyunsaturated fatty acids are known to prevent cardiovascular disease.

In addition to quantity and quality, the mode of consumption of fats appears important as smaller amounts of fats frequently during the day causes less elevation of cholesterol.

Energy from fats should be 20-30 per cent, EFA should be 3-6 per cent of total energy intake and ratio of omega-6 to omega -3 should be ideally 5:1 or 10:1. Normally in USA and Newzealand it is 20:1 or 30:1. Sources of omega 3 in various foods (Table 57.2).

*Limit Omega-6 Fats*

Limiting omega-6 intake is important for maximizing the conversion of omega-3s into EPA and DHA. One

Table 57.1: Dietary sources of essential and long-chain polyunsaturated fatty acids

	Omega 6	Sources	Omega 3	Sources
Essential fatty acids	Linoleic acid (18:2, $\omega$ -6)	Corn, soya, safflower and sunflower oils, green leafy vegetables, nuts, seeds	$\alpha$ -linolenic acid (18:3, $\omega$ -3) ( $\alpha$ -LNA)	Canola, flaxseed, walnut, soyabean oils, nuts and seeds
LCPUFA	Arachidonic acid (20:4, $\omega$ -6) Gamma linolenic acid (22:5, $\omega$ -6)	Egg yolk, meats (particularly organ meats) Evening primrose, blackcurrant, oils	Eicosapentanoic acid (20:5, $\omega$ -3) Docosahexaenoic acid (22:6, $\omega$ -3) Docosapentanoic acid (22:6, $\omega$ -3)	Fish oils, fish Fish oils, fish

**Table 57.2: Showing ratio of omega 6 to omega 3**

omega-3 source	approx. n-6:n-3 ratio
flaxseeds/flaxseed oil	1:4
canola oil	2:1
english walnuts	4:1 - 5:1
walnut oil	5:1
soyabean oil	7.5:1
black walnuts	10:1

should aim for an omega-6 to omega-3 ratio of 4:1 or less. The following sources of n-3s are followed by their approximate ratio of omega-6 to omega-3 (Table 57.2):

## CARBOHYDRATES

### Definition and Composition

Carbohydrates are a group of energy yielding organic compounds that consist of carbon, hydrogen, and oxygen and in their simplest form formula are  $C_nH_{2n}O_n$ . Only hexoses (six carbon sugars) and pentoses (five carbon sugars) play important role in nutrition.

#### Classification

- Monosaccharides which are the simplest form
- Disaccharides can be hydrolysed to give two monosaccharides and
- Oligosaccharides yield from 3-10 monosaccharides units
- Polysaccharides yield from 10-10,000 or more
- Food ingredients like simple sugars, cane sugars, glucose, honey are pure carbohydrates
- Grain foods, roots and tubers are largely composed of starch, a complex carbohydrate. When eaten in a cooked form they are completely digested in the gastrointestinal track and the released glucose is absorbed and metabolised in the body to yield energy.

#### What is the Glycaemic Index?

Glycaemic index (also glycaemic index, GI) is a ranking system for carbohydrates based on their immediate effect on blood glucose levels. It compares carbohydrates gram for gram in individual foods, providing a numerical,

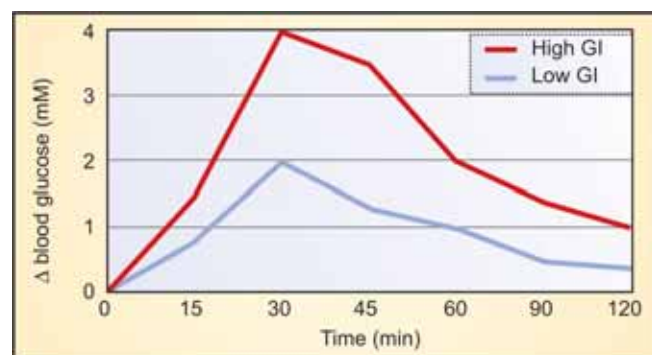
evidence-based index of postprandial (post-meal) glycaemia. The concept was invented by Dr. David J. Jenkins and colleagues in 1981 at the University of Toronto.

Carbohydrates that break down rapidly during digestion have the highest glycaemic indices. Such carbohydrates require less energy to be converted into glucose, which results in faster digestion and a quicker increase of blood glucose. Carbohydrates that break down slowly, releasing glucose gradually into the blood stream, have a low glycaemic index. A lower glycaemic index suggests slower rates of digestion and absorption of the sugars and starches in the foods and may also indicate greater extraction from the liver and periphery of the products of carbohydrate digestion. Additionally, a lower glycaemic response equates to a lower insulin demand, better long-term blood glucose control and a reduction in blood lipids.

The glycaemic index of a food is defined by the area under the 2 hour blood glucose response curve (AUC) (Fig. 57.3) following the ingestion of a fixed portion of carbohydrate (usually 50 g). The AUC of the test food is divided by the AUC of the standard (either glucose or white bread) and multiplied by 100.

Low GI	55 or less
Moderate GI	56 to 69 inclusive
High GI	70 or more

White bread, potato and many types of rice are digested and absorbed very quickly, giving them a high GI, sugar has only a moderate GI, so affects blood sugar quite modestly, often less than bread or rice.



**Fig. 57.3:** Illustration of the changes in blood glucose over time following a high and low GI carbohydrate.

*Glycaemic Index of Foods (Table 57.3)*

GI values can be interpreted intuitively as percentages on an absolute scale and are commonly interpreted as follows:

**Table 57.3: GI values classification**

Classification	GI range	Examples
Low GI	Below 55	sour dough bread (54), apple juice (40), pumpernickel (50), oatmeal (48), pasta (54), Indian Basmati Rice (58)
Intermediate GI	56 to 69	croissant (67) Coca-Cola (63) raisin bran (61) wholemeal bread (65)
High GI	Above 70	white bread (70), corn flakes (80), doughnut (76), white rice (98)

**Fibres**

Beside starch and other digestible carbohydrates many foods contain non-digestible carbohydrates like cellulose, hemicellulose, gums, pectins and lignins. These undigestible carbohydrates are designated as “dietary fibres” or “unavailable carbohydrates”.

1. They are voided as such in the stools and add bulk to the stools. Presence of fibre in the diet is necessary for the mechanism of digestion and elimination of waste, by contraction of the musculature of digestive tract they counteract tendency to constipation.
2. They increase transit time and reduce the time of release of ingested food in the colon. Adding fibre to diet decreases the chance of colon cancer.
3. Some of the dietary fibres like gums, mucilage in our diets have been shown to lower blood cholesterol in hypercholesterolaemic subjects and
4. Lower blood glucose in diabetes.

*Sources of Fibres*

Vegetables particularly the leafy ones, fruits, condiments, spices and unrefined cereals are comparatively rich in fibres and a generous inclusion of these provide a diet rich in fibre.

**RDA**

Recommendations by National Cancer Institute is 25-35 gm/day or 10-13 gm/1000 Kcal. Excessive fibre may interfere with absorption of Calcium and zinc especially in children and elderly.

**ENERGY**

Energy is required to sustain the body's various functions, including respiration, circulation, physical work, and maintenance of core body temperature. The energy in foods is released in the body by oxidation, yielding the chemical energy needed to sustain metabolism, nerve transmission, respiration, circulation, and physical work. The heat produced during these processes is used to maintain body temperature. Energy balance in an individual depends on his or her dietary energy intake and energy expenditure. Imbalances between intake and expenditure result in gains or losses of body components, mainly in the form of fat, and these determine changes in body weight.

REE (Resting energy expenditure) is energy used by body at rest and is defined in terms of either REE or BEE (Basal energy expenditure) and are measured as RMR or BMR. REE constitutes the largest portion of the TEE (Total energy expenditure). BMR is measured in the morning after 12 hours of fasting and RMR is measured at rest any time of the day with 3-4 hours of fasting. TEF (Thermic effect of food) reaches maximum after one hour of food and is dissipated after 4 hours.

The estimated energy requirement (EER) is defined as the average dietary energy intake that is predicted to maintain energy balance in a healthy, adult of a defined age, gender, weight, height, and level of physical activity consistent with good health. In children and pregnant or lactating women, the EER includes the needs associated with the deposition of tissues or the secretion of milk at rates consistent with good health. While the expected between-individual variability is calculated for the EER, there is no recommended dietary allowance (RDA) for energy because energy intakes above the EER would be expected to result in weight gain. Similarly, the tolerable upper intake level (UL) concept does not apply to energy.

Quantitative food requirements of food are usually in terms of energy i.e. calories. K cal is amount of heat necessary to raise the temperature of one Kg of water by 1°C from 14.5°C to 15.5°C. International union of nutritional sciences has adopted a new unit of energy called Joule. A Joule(J) is defined as the energy required to move 1 Kg mass by 1 Newton. One Newton is the force needed to accelerate 1 Kg by 1m per sec<sup>2</sup>.

- 1 Kcal = 4.184 kilojoule (KJ) or 4.2
- 1000 Kcal = 4.184 Megajoule (MJ) or .2 KJ

Table 57.4 shows approximate energy expenditure of various organs in body.

**Table 57.4: Approximated energy expenditure of organs in body**

Organ	% of REE
Liver, brain, heart, kidneys	29%, 19%, 10%
Skeletal muscle (at rest)	7%
Remainder	18%
	17%

REE decreases by 2-3 per cent per decade after early adulthood. More recent studies show that these changes in the body composition may not be age related at all. Exercise may help maintain higher lean body mass and higher RMR. Five kcal of extra energy is needed for gaining 5 gm, so roughly for gaining 1 kg body weight or losing that much, 1000 kcal are required or have to be consumed respectively.

In women REE fluctuates with menstruation, difference of 359 kcal/day had been seen in lowest one week before ovulation and high just before onset of menstruation and mean increment is about 150 kcal/day.

### Physical Activity

Contribution of physical activity to TEE is variable from 10 per cent in bedridden to 50 per cent in athletes.

### Dietary Reference Intakes

Dietary reference intakes (DRIs) comprise a set of reference values for specific nutrients, each category of which has special uses. The development of DRIs expands on the periodic reports called recommended dietary allowances, published from 1941 to 1989 by the National Academy of Sciences, and recommended nutrient intakes, published by the Canadian government.

The reference values, collectively called the dietary reference intakes (DRIs), include the estimated average requirement (EAR), recommended dietary allowance (RDA), adequate intake (AI), and tolerable upper intake level (UL).

**Recommended dietary allowance (RDA):** The average daily dietary nutrient intake level sufficient to meet the nutrient requirement of nearly all (97 to 98%) healthy individuals in a particular life stage and gender group.

**Adequate intake (AI):** The recommended average daily intake level based on observed or experimentally determined approximations or estimates of nutrient intake by a group (or groups) of apparently healthy people that are assumed to be adequately used when an RDA cannot be determined.

**Tolerable Upper Intake Level (UL):** The highest average daily nutrient intake level that is likely to pose no risk of adverse health effects to almost all individuals in the general population. As intake increases above the UL, the potential risk of adverse effects may increase.

**Estimated average requirement (EAR):** The average daily nutrient intake level estimated to meet the requirement of half the healthy individuals in a particular life stage and gender.

## ADOLESCENTS NUTRITION

### Definition of Adolescents

Adolescents are those who are aged between 10-19 years, young people 10-24 years, and youth between 15-24 years. The world's adolescent population — 1200 million persons of 10-19 years of age, or about 19 per cent of the total world's population — faces a series of serious nutritional challenges not only affecting their growth and development but also their livelihood as adults. Yet adolescents remain a largely neglected, difficult-to-measure, and hard-to-reach population, in which the needs of adolescent girls in particular are often ignored.

Adolescence is a particularly unique period in life because it is a time of intense physical, psychosocial, and cognitive development. It has increased nutritional needs because

1. Adolescents gain up to 50 per cent of their adult weight,
2. They gain more than 20 per cent of their adult height, and
3. 50 per cent of their adult skeletal mass during this period.
4. Caloric and protein requirements are maximal.
5. Increased physical activity, combined with poor eating habits changes their nutritional needs.
6. Other considerations, e.g. menstruation, in women REE fluctuates with menstruation, difference of 359 kcal/day had been seen in lowest one week before ovulation and high just before onset of menstruation and mean increment is about 150 kcal/day.

7. Pregnancy, contributes to accentuating the potential risk for adolescents of poor nutrition.

In summary, the main nutrition problems affecting adolescent populations worldwide include:

1. Obesity
  2. Undernutrition in terms of stunting and thinness, catch-up growth, and intrauterine growth retardation in pregnant adolescent girls;
  3. Iron deficiency and anaemia;
  4. Iodine deficiency;
  5. Vitamin A deficiency;
  6. Calcium deficiency;
  7. Specific nutrient deficiencies, e.g. zinc, folate.
- (WHO health topics updated: 03/13/2005 08:34:20).

## OBESITY IN ADOLESCENTS

### Obesity is Epidemic!

According to WHO classification incidence of more than 15 per cent means that there is epidemic and worldwide incidence of obesity is much more, in the last 10 years the incidence of obesity has doubled.

### Parametres of Obesity

#### For Scientific Studies

1. The level of fatness of a child at which morbidity acutely and/or later in life increases is determined on an actuarial basis. Direct measurements of body fat content, e.g. hydrodensitometry, bioimpedance, or DEXA, are useful tools in scientific studies only.

#### In Practice

We use BMI as a predictor of obesity i.e. wt. in Kg/ht sqm.

#### WHO Classification for Adults

- BMI 20-25 normal (for Asia 18-23)
- BMI 25-30 overweight
- BMI >30 obese
- BMI >40 morbid obese

BMI increases with increasing age, and also varies by pubertal stage and gender, so BMI percentiles are used to define degrees of overweight and obesity and normal weight in adolescents (Fig. 57.4).

- BMI > 85 centile for the age is overweight
- BMI > 95 centile is obese

## Aetiology of Obesity

1. Genetic factors explain a large part of the variation of body weight within a given population in a common environment.
2. Environmental factors tend to explain changes in obesity over time in that population.

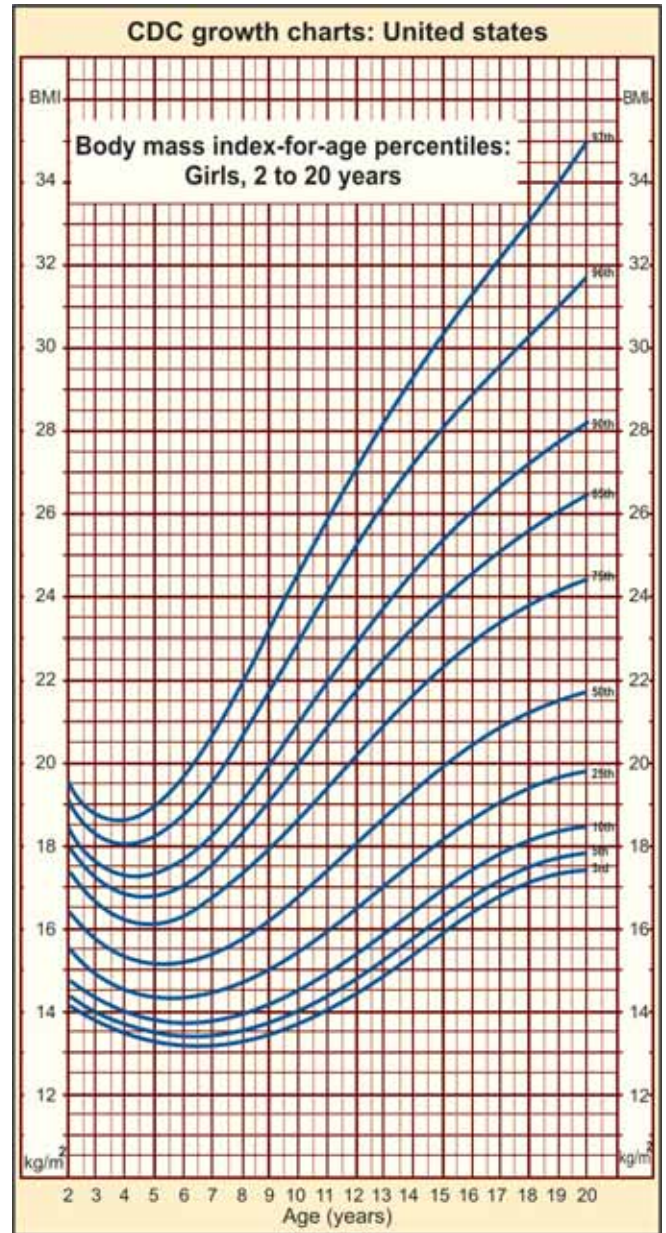


Fig. 57.4: CDC growth charts: United States

[Source: Developed by the national centre for health statistics in collaboration with the national centre for chronic disease prevention and health promotion (2000)]

- Adaptive responses to environmental conditions in gestation are proposed to produce a “thrifty phenotype” or metabolic program that affords an individual a better chance for survival. However, when that individual is then exposed to plentiful nutrition after birth, the metabolic program may be inappropriate for the new conditions and cause disease.

### Other Factors

- High birth weight has been associated with overweight and obesity in children, adolescents and adults.
- Infants of high weight relative to length at birth (e.g., ponderal index ( $\text{kg}/\text{m}^3$ )) have a higher degree of overweight or obesity in childhood and in adulthood.
- Higher a child’s or adolescent’s BMI and the older the child, the more likely they would be an overweight or obese adult.
- The mother’s and father’s own birth weights have been reported to have significance for the infant’s birth size.
- Height in adolescence is predicted by length and weight at birth and by parents’ height, whereas BMI is predicted by birth weight and parents’ BMI.
- Mother’s higher prepregnant weight or obesity has also been associated with children having higher weight at 2, 3 and 5 years of age and is responsible for obesity later on also.

These findings suggest that the intrauterine period has enduring effects on later body size but leave unresolved whether these effects are genetic or environmental. So a girl should have a proper nutrition in adolescents to prepare her for her pregnancy later on.

### Environmental Influences on Obesity

Epidemiologists have used cohort studies and case-control designs to determine which environmental factors may contribute to obesity. Such studies have pointed to

- Dietary trends
- Sedentary lifestyle
- Decreases in structured physical activity, and
- Psychosocial stressors as likely contributors to the obesity epidemic.

### Prevention of Obesity in Adolescents

#### Nutritional

- It should be balanced diet with plenty of low GI cereals, vegetables, fruits, low calorie yoghurt or double tone milk, legumes, nut, poultry, meat and fish
- Limited intake of salt and fats and
- Plenty of fluids. Sweetened beverages should be avoided
- No cold drinks like coke
- No TV viewing with food
- Family should eat together
- No fast foods like Pizzas
- Avoid excessive take-out or restaurant meals
- Meal skipping or inadequate meals (which often lead to out-of control eating later in the day)
- “Grazing” is bad, there should be meal-based eating habits
- Physical activity-one hour of intense physical activity like lawn tennis (Fig. 57.5)
- Withdrawing from sports or other physical activity should be prevented.

The various dietary requirements are shown in Table 57.6 to 57.9.

### Anaemia in Adolescent Girls

**Definition:** Anaemia is a condition of low circulating haemoglobin (Hb) in which Hb concentration has fallen below threshold lying two standard deviation below the median of a healthy population of the same age, sex, and



Fig. 57.5: Lawn tennis

same period of pregnancy. This is a statistical definition and WHO definition is less than 11 gm per cent in pregnant and <12 gm/dl in non pregnant and haematocrit of less than 0.33 (CDC).

**Incidence:** Globally it is 30 per cent and in developing countries it is 40-90 per cent.

Requirement of iron in adolescent girls is more as they are menstruating and iron stores are needed for future pregnancy and lactation. Iron deficiency is not only because of poor nutrition but because of:

1. Poor availability and lack of knowledge
2. Poor bio-availability of iron in vegetarian diet
3. Worm infestation
4. In countries like India males are given more preference, due to which nutrition of female adolescents suffers.
5. Chronic malaria.

**Diagnosis (Table 57.5):**

**Table 57.5: Classification of anaemia**

	Hb	Haematocrit %
Mild Anaemia	Hb 7-11.9 g/dl	24-37%
Moderate Anaemia	Hb 4-6.9 gm/dl	13-23%
Severe Anaemia	Hb<4 gm/dl	<13%

Iron loss is 1-2 mg/day from skin, urine and faeces. Iron loss because of menstruation is 20-30 mg/cycle, so total 2-3 mg/day, i.e. 20-30 mg/day is required in diet.

When the diet is deficient or adolescent girl is anaemic then iron supplementation is required in the form of oral I/M or I/V iron or in acute emergencies and severe anaemia by blood transfusion.

**Sources of Iron in Diet**

Food iron is present in most diets in a proportion of 6 mg/1000 cal and is made of two different pools: Haem and non haem iron. The haem iron pool includes all food containing iron as haem molecules like animal blood, flesh and viscera. Its absorption in normal women is 15-30 per cent but it can increase to 50 per cent in the iron deficiency state and can reduce to 5-8 per cent with excessive haem. Its absorption is usually not affected by inhibitors.

The non-haem iron pool is made of all sources of iron such as cereals, seeds, vegetables, beans, whole wheat flour, milk and eggs.

**Bioavailability or Iron Absorption**

Iron absorption is increased by:

1. Ascorbic acid
2. Haem-proteins
3. Fermentation, ferrous ions
4. Gastric acidity
5. Absorption is also increased at high altitudes
6. Haemolysis and bleeding.

Inhibitors of iron absorption are:

1. Phytates in diet
2. Calcium
3. Tannins
4. Tea and coffee
5. Herbal drinks
6. Fortified iron supplements.

So to increase bioavailability of iron in vegetarian diets, citrus fruits and juices should be taken with meals. Adding vitamin C sources like tomatoes, potatoes, amla with the diet in vegetarians would also increase the bioavailability of iron. Other recommendation is cooking food in iron utensils.

**Folic Acid**

Folic acid is required for the nucleic acid metabolism and for cell division and growth. Its deficiency causes megaloblastic anaemia, neural tube defects, homocysta-naemia. It also prevents isolated cleft lip congenital anomalies.

Sources of Folic acid are green leafy vegetables, fruits, liver, kidney. RDA for adolescents girls is 500 microgram/day.

Deficiency can occur by:

1. Prolonged cooking which destroys the vitamin
2. Body reserves of folic acid are low
3. Intake of goat's milk which is low in folic acid could be cause of deficiency in rural areas
4. Malabsorption syndrome
5. Hook worm infestation
6. Chronic malaria and
7. Antifolate treatment such as antiepileptic drugs which can cause deficiency of folic acid.

Folic acid supplementation should be given to all adolescent girls preconceptionally. 500 microgram/day in low risk cases and in the high risk cases, with H/O previous neural tube defect should be given in the dose of 5 mg/day minimum one month before conception. Iron and folate should be given together.



**Table 57.6: Dietary Reference Intakes (DRIs): Recommended Intakes for Individuals, Vitamins. Food and Nutrition Board, Institute of Medicine, National Academies**

<i>Life Stage Group</i>	<i>Vitamin A (µg/d)<sup>a</sup></i>	<i>Vitamin C (mg/d)</i>	<i>Vitamin D (µg/d)</i>	<i>Vitamin E (mg/d)</i>	<i>Vitamin K (µg/d)</i>	<i>Thiamine (mg/d)</i>
<b>Females</b>						
9-13 years	600	45	5*	11	60*	0.9
14-18 years	700	65	5*	15	75*	1.0
19-30 years	700	75	5*	15	90*	1.1
31-50 years	700	75	5*	15	90*	1.1
51-70 years	700	75	10*	15	90*	1.1
> 70 years	700	75	15*	15	90*	1.1
<b>Pregnancy</b>						
14-18 years	750	80	5*	15	75*	1.4
19-30 years	770	85	5*	15	90*	1.4
31-50 years	770	85	5*	15	90*	1.4
<b>Lactation</b>						
14-18 years	1,200	115	5*	19	75*	1.4
19-30 years	1,300	120	5*	19	90*	1.4
31-50 years	1,300	120	5*	19	90*	1.4

Note: This table (taken from the DRI reports, presents recommended dietary allowances (RDAs) in bold type and Adequate Intakes (AIs) in ordinary type followed by an asterisk (\*). Individuals covered by this intake.<sup>a</sup>

**Table 57.7: Dietary Reference Intakes (DRIs): Recommended Intakes for Individuals, Elements. Food and Nutrition Board, Institute of Medicine, National Academies**

<i>Life Stage Group</i>	<i>Calcium (mg/d)</i>	<i>Chromium (µg/d)</i>	<i>Copper (µg/d)</i>	<i>Fluoride (mg/d)</i>	<i>Iodine (µg/d)</i>	<i>Iron (mg/d)</i>	<i>Magnesium (mg/d)</i>
<b>Females</b>							
9-13 years	1,300*	21*	700	2*	120	8	240
14-18 years	1,300*	24*	890	3*	150	15	360
19-30 years	1,000*	25*	900	3*	150	18	310
31-50 years	1,000*	25*	900	3*	150	18	320
51-70 years	1,200*	20*	900	3*	150	8	320
> 70 years	1,200*	20*	900	3*	150	8	320
<b>Pregnancy</b>							
14-18 years	1,300*	29*	1,000	3*	220	27	400
19-30 years	1,000*	30*	1,000	3*	220	27	350
31-50 years	1,000*	30*	1,000	3*	220	27	360
<b>Lactation</b>							
14-18 years	1,300*	44*	1,300	3*	290	10	360
19-30 years	1,000*	45*	1,300	3*	290	9	310
31-50 years	1,000*	45*	1,300	3*	290	9	320

Note: This table presents recommended dietary allowances (RDAs) in bold type and adequate intakes (AIs) in ordinary type followed by an asterisk (\*).

**Table 57.8: Dietary Reference Intakes (DRIs): Recommended Intakes for Individuals, Total Water and Macronutrients**  
 Food and Nutrition Board, Institute of Medicine, National Academies

<i>Life Stage Group</i>	<i>Total Water<sup>a</sup> (L/d)</i>	<i>Carbohydrate (g/d)</i>	<i>Total Fibre (g/d)</i>	<i>Fat (g/d)</i>	<i>Linoleic Acid (g/d)</i>	<i>α-Linolenic Acid (g/d)</i>	<i>Protein (g/d)</i>
<b>Females</b>							
9-13 years	2.1*	130	26*	ND	10*	1.0*	34
14-18 years	2.3*	130	26*	ND	11*	1.1*	46
19-30 years	2.7*	130	25*	ND	12*	1.1*	46
31-50 years	2.7*	130	25*	ND	12*	1.1*	46
51-70 years	2.7*	130	21*	ND	11*	1.1*	46
> 70 years	2.7*	130	21*	ND	11*	1.1*	46
<b>Pregnancy</b>							
14-18 years	3.0*	175	28*	ND	13*	1.4*	71
19-30 years	3.0*	175	28*	ND	13*	1.4*	71
31-50 years	3.0*	175	28*	ND	13*	1.4*	71
<b>Lactation</b>							
14-18 years	3.8*	210	29*	ND	13*	1.3*	71
19-30 years	3.8*	210	29*	ND	13*	1.3*	71
31-50 years	3.8*	210	29*	ND	13*	1.3*	71

Note: This table presents recommended dietary allowances (RDAs) in bold type and adequate intakes (AIs) in ordinary type followed by an asterisk (\*). <sup>a</sup> Total water includes all water contained in food, beverages, and drinking

**Table 57.9: Dietary Reference Intakes (DRIs): Acceptable Macronutrient Distribution Ranges.** Food and Nutrition Board, Institute of Medicine, National Academies

<i>Macronutrient</i>	<i>Range (per cent of energy)</i>		
	<i>Children, 1-3 years</i>	<i>Children, 4-18 years</i>	<i>Adults</i>
Fat	30-40	25-35	20-35
<i>n</i> -6 Polyunsaturated fatty acids <sup>a</sup> (linoleic acid)	5-10	5-10	5-10
<i>n</i> -3 Polyunsaturated fatty acids <sup>a</sup> (α-linolenic acid)	0.6-1.2	0.6-1.2	0.6-1.2
Carbohydrate	45-65	45-65	45-65
Protein	5-20	10-30	10-35

<sup>a</sup> Approximately 10 per cent of the total can come from longer-chain *n*-3 or *n*-6 fatty acids.

Source: Dietary reference intakes for energy, carbohydrate, fiber, fat, fatty acids, cholesterol, protein, and amino acids (2002/2005).

## Iodine Deficiency Disorders

The disorders induced by dietary iodine deficiency (IDD) constitute a major global nutrition concern. Globally about 740 million people are affected by goitre, and more than 2 billion (or over 38% of the population living in 130 countries) are estimated to be at risk of IDD. Many countries — including China and India — have come to regard their entire population as at risk of IDD.

Iodine is required for the synthesis of thyroid hormones, which are involved in regulating metabolic activities of all cells throughout the life cycle. In addition,

it plays a key role in cell replication. This is particularly relevant for the brain since neural cells multiply mainly *in utero* and during the first two years of life. IDD comprises all the effects of iodine deficiency.

- In the foetus these effects lead to increased rates of abortion
  - Still-births
  - Congenital anomalies
  - Cretinism, psychomotor defects, and
  - Neonatal mortality.
- In the child and adolescent, the effects manifest as:
- Goitre

- Hypothyroidism, impaired mental function
- Retarded mental and physical development, and
- Diminished school performance.

In adults, goitre and its complications, hypothyroidism, and impaired mental function persist.

Urinary iodine is a marker of very recent dietary iodine intake. The normal population median value of urinary iodine is 100-200 µg/L. Values of 50-99 µg/L suggest mild iodine deficiency, while values of 20-49 and below 20 µg/L suggest moderate and severe iodine deficiency, respectively.

### Prevention and Control

Establishing and sustaining national salt iodisation schemes. Globally, 68 per cent of households in countries with IDD now consume iodised salt. Iodisation rates are highest in the Americas at 90 per cent. Africa has achieved a level of 63 per cent.

### Vitamin A deficiency (VAD)

Vitamin A is an essential micronutrient for the normal functioning of the visual system, growth and development, maintenance of epithelial cellular integrity, immune function, and reproduction.

### Sources of Vitamin A

Vitamin A or retinol is present in some animal foods like butter, ghee, whole milk, curds, egg yolk, liver etc. The liver oil of certain fish like cod, halibut, shark and saw fish are some of the richest known sources of vitamin A. In vegetables vitamin A is present as carotene and 1 microgram of carotene yields 0.5 microgram of retinol and carotene present in food is not completely absorbed. The rich source of beta carotene are green leafy vegetables, spinach, amaranth, coriander, drumstick leaves, curry leaves, mint, raddish leaves etc. and ripe yellow fruits such as mangoes, papaya, tomatoes, and carrots and yellow pumpkin. Red palm oil (RPO) is another very good source of vitamin A, 1 g of RPO contains 800 microgram of beta carotene. RDA for adolescents is about 700 microgram (2500 IU) of Vit A, so intake from vegetables should be 3500 microgram of beta carotene as conversion of beta carotene to vitamin A is 50 per cent and absorption from vegetables sources is 50 per cent, so about 50 gm of green leafy vegetables like amaranth would give required amount, or 100 gm of mangoes, 200 gm of papaya etc. In addition to natural

sources vitamin A is available as synthetic source also and are being given to children (200000 IU/mg) in the National Nutritional Blindness Control Programme.

### Clinical Sign of Deficiency

1. Night blindness
2. Bitot's spots
3. Corneal xerosis and/or ulcerations
4. Xerophthalmia-related corneal scars
5. Subclinical deficiency of vitamin A for preschool-age children is defined as the prevalence of serum retinol values  $< 0.70 \mu\text{mol/L}$  minus the prevalence of clinical vitamin A deficiency.
6. Among well-nourished, healthy populations of preschool-age children, and even those still living in poverty but whose vitamin A status is adequate, fewer than 5 per cent have values less than  $0.70 \mu\text{mol/L}$ .

### Prevention

1. Vitamin A supplementation to all children
2. Promotion of egg consumption
3. Fortification of food like maize and sugar with vitamin A.

### Under Nutrition or Stunting in Adolescents

(ACC/SCN (2000) *Fourth Report on the World Nutrition Situation*. Geneva: ACC/SCN in collaboration with IFPRI).

Adolescence is a transition phase when children become adults. During adolescence hormonal changes accelerate growth in height. Growth is faster than at any other time in the individual's postnatal life except the first year.

Prevalence of stunting varies from 27-65 per cent in different countries. (ICRW-International Center for Research on Women).

Can undernourished children catch up on incomplete childhood growth during adolescence if given proper nutrition?

Data is insufficient regarding this, even if adolescent catch-up growth could be brought about by an intervention and stunting thus reduced, this would not necessarily rectify all of the problems for which stunting is merely a marker. For example, while a reduction in stunting would probably reduce obstetric risk due to small maternal size, it would not necessarily reverse the effects of early childhood stunting on cognitive function.

Under weight and under nourished girls are at increased risk of following complications:

1. Under nourished girls reach menarche later and growth is slower.
2. Height attained at the end of menarche is less with growth stunted in early childhood.
3. They get pregnant before their growth is complete. In India, for example, up to 67 per cent of girls were classified as at obstetric risk (by weight and height criteria) in their 15th year compared with about 20 per cent in their 19th year. The mean age of first conception was 15.3 years in six large North Indian states.
4. The stunted adolescent become stunted adults, 67 per cent of severely stunted and 34 per cent of moderately stunted become stunted women.
5. They are at more risk of obstructed labour.
6. In another study in India, early childhood stunting among young girls was found, a generation later, to be significantly related to the low birthweights and infant mortality risk of their children.
7. Increased risk of premature births and increased risk of maternal and foetal mortality, almost twice as much as adult mothers.

### Calcium Requirements in Adolescents

1. RDA for calcium is 1300 mg/day but this varies and depends on many factors. Adequate calcium intakes are affected by many variable factors including age, gender, physical activity, and multiple dietary considerations. Genetic and ethnic variability are also important factors.
2. The current dietary intake of calcium by children and adolescents is well below the recommended optimal levels. The available data support recent recommendations for calcium intakes of 1200 to 1500 mg/day beginning during the preteen years and continuing throughout adolescence.
3. Optimising calcium intake is particularly important during adolescence. Peak calcium-accretion rate is attained at an average of 12.5 years of age in girls and 14.0 years of age in boys. During the 3 to 4-year period of increased bone mass acquisition that occurs during adolescence, 40 per cent of total lifetime bone mass is accumulated.
4. However, available data suggest that if calcium is supplemented for short time periods (i.e, 1-2 years), there may be no long-term benefit in attaining and

maintaining a maximum peak bone mass. This emphasises the importance of establishing dietary practices in childhood that promote adequate calcium intake throughout life (NAS). This would prevent osteoporosis later in life.

5. The gap between the recommended calcium intakes and the typical intakes of children, especially those 9 to 18 years of age, is substantial. Mean intakes in this age group are between approximately 700 and 1000 mg/day, with values at the higher side of this range occurring in males. Preoccupation with being thin is common in this age group, especially among females, as is the misconception that all dairy foods are fattening. Many children and adolescents are unaware that low-fat milk contains at least as much calcium as whole milk, rather more than that.
6. The efficiency of calcium absorption is increased during puberty, and the majority of bone formation occurs during this period.
7. Knowledge of dietary calcium sources is a first step towards increasing the intake of calcium-rich foods. Table 57.10 gives typical amounts of calcium for some common food sources. The largest source of dietary calcium for most persons is milk and other dairy products. Other sources of calcium are, however, important, especially for achieving calcium intakes of 1200 to 1500 mg/day. Most vegetables contain calcium, although at low density. Therefore, relatively large servings are needed to equal the total intake achieved with typical servings of dairy products. The bioavailability of calcium from vegetables is generally high. An exception is spinach, which is high in oxalate, making the calcium virtually nonbioavailable. Some high-phytate foods, such as whole bran cereals, also may have poorly bioavailable calcium.
8. Physical activity, primarily weight-bearing exercise, is encouraged as part of an overall healthy bone program.

### NUTRITION IN PREGNANCY

Nutrition in pregnancy plays a crucial role because it decides morbidity and mortality both for mother and foetus.

1. Every minute, one woman somewhere in the world dies from a complication related to pregnancy or childbirth.
2. In India, one woman dies every five minutes from a pregnancy-related cause.

Table 57.10: Approximate Calcium Contents of 1 Serving of Some Common Foods

Food Serving Size	Calcium Content
Milk 1 cup (240 ml)	300 mg
White beans 1/2 cup (110 g)	113 mg
Broccoli cooked 1/2 cup (71 g)	35 mg
Broccoli raw 1 cup (71 g)	35 mg
Cheddar cheese 1.5 oz (42 g)	300 mg
Low-fat yogurt 8 oz (240 g)	300-415 mg
Spinach cooked 1/2 cup (90 g)	120 mg
Spinach raw 1 1/2 cup (90 g)	120 mg
Calcium-fortified orange juice 1 cup (240 ml)	300 mg
Orange 1 medium (1 medium)	50 mg
Sardines or salmon with bones 20 sardines (240 g)	50 mg
Sweet potatoes 1/2 cup mashed (160)	44

In developing countries, many women are short and underweight and the number of low birthweight (LBW) babies is particularly high (more than 30 per cent in South Asia, 10-20 per cent in other regions). LBW infants have less chance of survival; when they do survive, they are more prone to disease, growth retardation and impaired mental development. A good start in life is important and maternal nutritional status during pregnancy has repeatedly been demonstrated to be associated with pregnancy outcomes for the infant.

### Causes of Maternal Mortality

1. Inadequate nutrition is a significant factor contributing to maternal deaths.
2. Anaemia is responsible for 40-60 per cent of maternal deaths in non-industrialised countries and it is mainly nutritional anaemia.
3. Adolescent mothers are at great risk because they are most of the time undernourished, underweight and anaemic and this leads to all the complications of pregnancy like low birth weight, high mortality, anaemia, toxemia and perinatal loss.

### What is Adequate Nutrition for a Childbearing Woman?

Proteins, carbohydrates, fats, vitamins, minerals and water are all necessary to achieve adequate nutrition in pregnancy. Height, weight, activity level nutritional stress factors, plus 300 calories per day determine calorie

requirements. Nutritional stress factors are nausea, vomiting and weight loss for a prolonged period, pregnancy spacing less than one year apart, prior poor obstetrical outcomes (stillbirths, spontaneous abortions, preterm deliveries), failure to gain adequate weight, age under 20 years, and emotional stress. For each stress factor add an additional 200 calories (400 extra calories maximum). Calorie requirements will need to be refigured during pregnancy since very athletic women may become less active, there will be weight gain and/or loss, and there may be changing stress factors affecting the formula.

### Macronutrients

Approximately 20-25 per cent of calories in protein, 45-55 per cent in carbohydrate and 30 per cent in fat is an effective balance of macronutrients for insuring a steady level of blood sugar and nutrients. Consuming mini-meals of a few hundred calories every two to three hours is effective for patients who wish to avoid erratic energy states. Due to the metabolic preference to meet the foetal demand for energy and the tendency toward prenatal hyperinsulinaemia, this strategy helps prevent blood sugar fluctuations.

### Nutrition during Pregnancy

- High nutrient needs for the tremendous growth of foetus. Whatever weight woman gains during pregnancy, about 40 per cent goes to foetus, placenta

and liquor amnii and rest is used for maternal weight gain, uterus, breasts, blood, interstitial tissues and body fat. Foetal weight is needed for foetal survival and in low birth weight babies, (LBW), foetal mortality is forty times higher.

- Maternal stores laid down during pregnancy are needed for lactation.
- Physiological adaptations during pregnancy partly shield the foetus of inadequacies in maternal diet but they can have consequences for both short and long term health and development of the foetus and infant. These can lead onto metabolic syndrome later on in their life.

### Physiological Changes in Pregnancy

1. Expansion of plasma volume by up to 50 per cent, reaching a plateau in the middle of the third trimester
2. Active transport of certain nutrients from the maternal circulation across the placenta, amino acids, iron, zinc, water soluble vitamin except niacin.
3. Gestational hormone-induced fat mobilisation that increases triglycerides and cholesterol levels by approximately 40 per cent or more and fat soluble vitamins (betacarotene, vitamin D, and vitamin E, but not vitamin A) levels by 30 to 120 per cent.

Nutrition in pregnancy has been recognised for millennia as being important, but the current nutritional practices of pregnant women often do not conform to what we already know to be optimum. Pregnant women are increasingly entering pregnancy overweight as the dietary habits of young women deteriorate in many societies. This increase in overweight was accompanied by a 5-fold increase in gestational diabetes within 15 years in Norway, together with an unprecedented increase in the prevalence of large babies. This is accompanied by increasing risks of foetal malformations, damage to mother and child during parturition, and an increased risk of both obesity and type 2 diabetes in mother and the adolescent child. The prevalence of overweight girls is therefore a public health challenge with intergenerational implications.

### Recommended Weight Gain By BMI (Wt in Kg/Ht in Sqm) (Table 57.11)

Adolescents should strive for gains at the upper end of the recommended range.

Short women (<1.57 m) should strive for gains at the lower end of the range.

**Table 57.11: Recommended total weight gain in pregnant women by pre-pregnancy BMI (kg/m<sup>2</sup>)**

Weight-for-height category	Recommended total gain (kg)
Low (BMI < 19.8)	12.5–18
Normal (BMI 19.8–26.0)	11.5–16
High BMI (BMI > 26.0–29.0)	7–11
Obese (BMI > 29.0)	≥ 6.0

Source: Institute of Medicine 1990.

**Table 57.12: Appropriate BMI cut-offs for estimated equivalent fat tissue proportions**

Classification	BMI (kg/m <sup>2</sup> )		
	Caucasian populations <sup>a</sup>	Polynesian populations <sup>b</sup>	Asian populations <sup>c</sup>
Underweight	<18.5	<18.5	<18.5
Normal range	18.5–24.9	18.5–25.9	18.5–22.9
Overweight	25–29.9	26–31.0	23–27.4
Obese	>30	>32	>27.5

Sources: <sup>a</sup> WHO 2000, <sup>b</sup> Swinburn *et al* 1999, <sup>c</sup> WHO 2004.

For Indians and Asian population cut off for BMI is less as they have more of subcutaneous fat (Table 57.12).

Weight gains outside the Institute of Medicine's suggested ranges are associated with double the number of poor pregnancy outcomes as weight gains within the ranges.

Foetal weight depends on following factors:

1. Maternal weight gain during pregnancy
2. Maternal birth weight
3. Maternal weight at the onset of pregnancy

A study of human ovum donation has shown that an affluent intrauterine environment provided by a heavy recipient mother produces heavier babies, regardless of the genetic contribution of the donor mother.

### Energy Requirements During Pregnancy

Energy requirements increase in pregnancy by about 12 per cent. This is because of the increase in maternal body weight, an average 10–15 per cent increase in basal metabolic rate (BMR) and the energy costs of the growing foetus and maternal physiological changes in pregnancy. Energy requirements are higher in later pregnancy but may be, at least partially, offset by mobilisation of fat stored in early pregnancy.

Normally women require 300 kcal more than their normal prepregnancy requirements during second and 450 kcal in third trimester and not during first trimester unless woman is underweight to start with. She should gain about 400 gms/week. Women carrying twins should gain 35 to 45 pounds or approximately need 150 kcal a day more than for a singleton pregnancy. Women pregnant with twins should gain approximately 4 to 6 pounds during the first trimester and 1.5 lb/week thereafter. This weight gain is associated with a decreased risk of preterm delivery and low-birth-weight infants. Only two studies have assessed weight gain in triplet pregnancies. A weight gain of 50 pounds in total, or approximately 1.5 lb/week throughout pregnancy, may be appropriate.

Energy deprivation in pregnancy leads to metabolic syndrome later on in life of the baby.

It is hypothesised that some chronic adult diseases originate *in utero* as a result of foetal adaptation to optimise survival (Godfrey and Barker 2000) (Fig. 57.6). Low birthweight has been associated with increased risk of later development of Type 2 diabetes mellitus, heart disease, hypertension, obstructive lung disease, hypercholesterolaemia renal damage and PCOD.

An increase in carbohydrate consumption is preferred during pregnancy and lactation, because the foetus and mammary gland tend to use glucose.

### Energy Requirement During Lactation

During lactation women require extra energy for milk production and it is generally between 475-500 Kcal.

### Iron

Iron deficiency has been documented throughout the world, particularly in developing countries. Because of

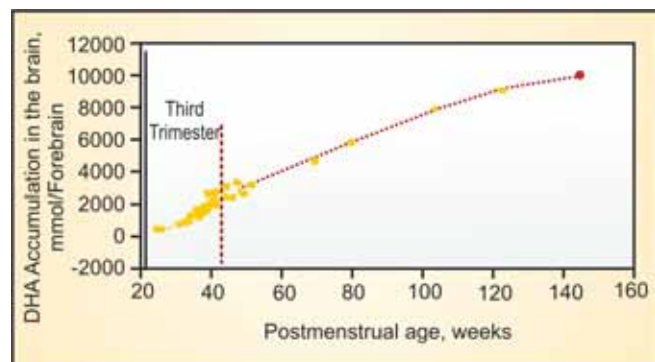


Fig. 57.6: DHA accumulates in the brain beginning *in utero* through childhood

increased iron use during pregnancy for the increase in maternal red cell mass, for foetal erythropoiesis, and for replacing blood lost during delivery, approximately 1040 mg of iron is needed during pregnancy, 840 mg of which is lost from the body during delivery and 200 mg of which is returned to storage as blood volume decreases postpartum. Although iron needs increase little during the first trimester because of cessation of menses, an RDA of 27 mg/day is recommended throughout pregnancy to fulfill the new needs and prevent depletion of maternal iron stores. The UL is set at 45 mg/day.

Iron deficiency results in maternal anaemia, defined by a haematocrit of less than 32 per cent and haemoglobin level less than 11 g/dl, and foetal iron deficiency anaemia. Normal diet provides 6 to 7 mg/1000 kcal of iron so iron supplementation is required in pregnancy.

Routine prophylactic iron supplementation of 65 mg/day from 20 weeks of gestation to prevent iron deficiency anaemia is advocated and for established iron deficiency, as reflected by a serum ferritin level below 12 µg/L or a hypochromic microcytic anaemia, some recommend taking 120 to 150 mg/day of elemental iron, in divided doses, until the haemoglobin level is more than 12 g/dl and the serum ferritin level is more than 35 µg/L.

Female adolescents need routine iron supplementation.

### Calcium

The RDA for calcium is 1200 mg/day. There is increase in 1,25-dihydroxyvitamin D levels (up to twice postpartum values), which leads to an increase in intestinal calcium absorption. The increase is so large that it exceeds the calcium needs and results in 2.5-fold higher urinary calcium excretion during pregnancy than postpartum.

Multiparous women with poor calcium intake may develop clinical osteomalacia, and the foetal bone density may be similarly affected. Leg cramps during pregnancy may reflect altered calcium or magnesium metabolism.

Calcium supplementation of 1 to 2 g/day during pregnancy may reduce the risk of developing the hypertensive disorders of pregnancy, including pregnancy-induced hypertension, pre-eclampsia, and eclampsia.

### Zinc

The RDA for zinc for pregnant women is 11 mg/day, three grams more than that allotted for the nonpregnant

woman, although up to 40 mg/day is considered safe. The RDA is doubled for vegetarians because less zinc is absorbed with this diet. Without supplementation, zinc levels normally decrease during pregnancy, especially between weeks 14 and 35. Even with adequate supplementation, zinc levels decrease by 20 to 35 per cent below prepregnancy levels, possibly the result of increases in blood volume, gestational oestrogens, foetal needs, and the gestational decrease in albumin, which binds zinc. Plasma zinc concentrations decline more precipitously when iron is supplemented orally as a result of competition for absorption by these two ions.

Populations at risk for zinc deficiency include:

- Vegetarians
- Alcoholics
- Smokers
- Teenagers
- Multigravidas with impaired intestinal absorption of zinc
- Women receiving diuretics
- Those with an acute stress response to infection or trauma.

Zinc deficiency has been associated with:

- Foetal intrauterine growth retardation
- Congenital malformations
- Premature and postmature births
- Low birth weight
- Perinatal death
- Abnormal delivery with dystocia and placenta abruption
- Gestational zinc deficiency can impair the development of the foetal immune system and impair neurogenesis and subsequent cognitive development, thereby influencing activity, attention, and neuropsychologic performance.

### Iodine

The current RDA for iodine is 150 µg/day in nonpregnant females, increasing to 220 µg/day during pregnancy. Maternal deficiency can cause miscarriage, stillbirth, congenital anomalies, goitre, cretinism, impaired brain function, and hypothyroidism. Iodine deficiency is estimated to cause a reduction of 10 to 15 per cent on scores in intellectual tests. The extent of cognitive damage correlates with the severity of the deficiency. Moreover, maternal deficiency might compromise neonatal neurologic development even when it does not cause cretinism. Treatment of iodine

deficiency during the first trimester may prevent foetal toxicity from iodine deficiency. Later supplementation may improve brain growth and development slightly, but does not improve neurologic status.

### Essential Fatty Acids

Recommendations are an n-3 intake for non-vegetarians of about 1.3 per cent of calories. They recommended an additional 300 mg/day of DHA for pregnant and lactating non-vegetarians. Limiting n-6 intake and increasing intake of ALA to 1.5 per cent of calories will enhance conversion of ALA to EPA and DHA; however, it can sometimes take a few months of following these recommendations to build up DHA. Based on the recommended dietary allowance (RDA) for caloric intake (and subtracting 0.5% of kcal for usual ALA intake without any supplementation), the following amounts of ALA should be added to the diet (Table 57.13):

**Table 57.13: Amounts of ALA to be added to diet**

Age(years)	ALA(g/day)	Flaxseed oil (rounded teaspoons)
0.5-6	.9 - 2.0	0.5
> 7	2.2 - 3.3	1
<i>Pregnant<sup>A</sup></i>		
2nd Trimester	An extra 0.3	An extra 0.5
3rd Trimester	An extra 0.3	An extra 0.5
<i>Lactating<sup>A</sup></i>	extra 0.6	extra 0.5

A - Pregnant and lactating women should consider replacing the extra 0.5 teaspoon of flaxseed oil with 300 mg (0.3 g) of DHA because infants have more difficulty converting n-3s.

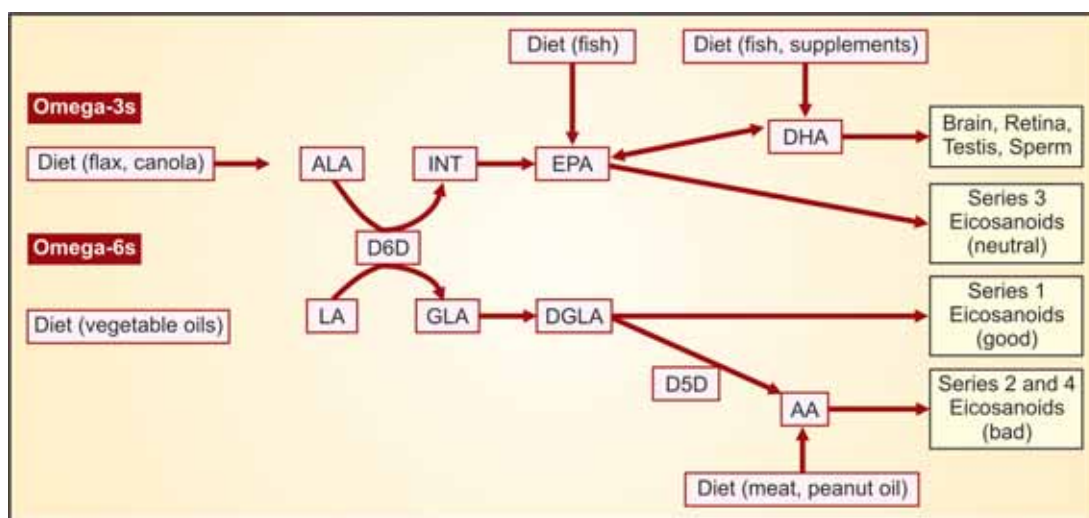
### Nutrition in Elderly

As the life expectancy is increasing so is the number of elderly people and it has increased from 4 per cent of population in 1900 to 13 per cent in 1990 and it would reach to 20 per cent of population by the year 2030. (Rubenstein, 1990). And too often this is also a group most susceptible to many health risks from a nutrient poor diet. Traditionally, the elderly group has been defined as 65 and beyond. Another definitive grouping is 65-75 (young old), 75-85 (old) and 85 above as oldest old.

Poor nutrition is implicated as a contributing factor in 5 of the 10 leading causes of death in women – coronary heart disease, cancer, stroke, diabetes, and diseases of the liver and kidneys. It's also a key factor in osteoporosis, putting women especially at risk for



**Flow chart 57.1:** Showing metabolism of Omega-3 and Omega-6 fatty acids



fractures of the hip, wrist, back and other bones. Since adequate nutrition is critical to health, functioning, and the quality of life, it is an important component of home and community-based services for older people.

Factors responsible for low nutrition in elderly are:

- Decreased sense of taste, smell, sight, hearing and touch are responsible for diminished food intake as decreased appetite, food recognition and the ability to feed oneself is there and also decreased secretion of gastric, pancreatic and salivary secretions and so impaired metabolic processes.
- Oral health status:
  1. Lack of salivation
  2. Tooth loss and wearing of dentures so 75-85 per cent impairment of capacity to chew food and less consumption of meats and fresh fruits and so inadequate intake of nutrients.
- **Gastrointestinal:** In the elderly people there is hypochlorhydria so less absorption of Vitamin B<sub>12</sub>. Intestinal absorption of calcium decreases with age between the ages of 50-60 and fibre recommended for constipation may also alter calcium absorption. Constipation is there because of slackened muscle tone and inadequate fluid intake and inactivity. Laxative use is also associated with hypoalbuminaemia.
- **Metabolic:** Decrease in glucose tolerance associated with aging process leads to an increase in plasma glucose of 1.5 mg/dL per decade. BMR decreases by

20 per cent between the ages of 30 and 90 because of decreased body mass.

Exposure to sunlight triggers vitamin D synthesis in the skin, but older women don't convert sunlight into essential vitamin D as efficiently as they did when they were younger, nor do they process another essential vitamin – B<sub>12</sub> as well as they once did.

- **Sarcopenia:** This is the most significant change in the elderly that is decrease in lean muscle mass of the body and this affects BMR, appetite, insulin sensitivity breathing, ambulation, mobility and independence of the elderly.

This is also associated with decrease in bone mineral density, which predisposes them to fragility fractures.

- **Neurological changes:** Changes in cognitive function are also responsible for decreased food intake.
- Psychosocial:
  1. Depression
  2. Homebound because of fear
  3. Low income
  4. Immobility

### Nutritional Requirements of Elderly

#### Energy

RDA for elderly calls for a reduction in energy intake after 51 years of age, 600 kcal/day for men and 300 Kcal for women. But it should not be less than 1800 Kcal/day

otherwise it would be deficient in protein, calcium, iron and vitamins so nutrient dense food should be planned for them.

### *Protein*

Body protein in healthy elderly is 60-70 per cent of that of young adults but still protein intake of 1.0 gm/kg daily is best for them for nitrogen balance.

### *Carbohydrate*

RDA for carbohydrates is at least 55 per cent of calories and mainly from complex carbohydrates. Diminished lactase secretion frequently leads to lactose intolerance and in these cases lactase treated milk and fermented dairy products would alleviate the symptoms of flatulence, cramping and diarrhoea.

### *Fat*

Thirty per cent of calories should be from fats and they should be in combination. One of the unfortunate consequences of the lower-fat diet message is that often the replacement for fat calories are calories from simple carbohydrates which can elevate plasma triglyceride levels resulting in lower HDL cholesterol concentrations which has been shown to be an important determinant of CHD risk in the elderly. An additional effect of low fat, high simple carbohydrate diet is to increase the expression of LDL particles, so calories from fat should not be reduced.

### *Minerals*

Calcium requirement in menopausal women is 1200-1500 mg/day. As calcium absorption is decreased it results in osteoporosis and hypochlorhydria. All these factors cause increased demand of calcium. But along with calcium we have to advise weight bearing exercises to decrease bone resorption and calcium deposition. In those taking diuretics for hypertension sodium intake should be reduced to 2-4 mg/day and potassium and magnesium should be supplemented.

### *Vitamins*

As the capacity of the skin to synthesise vitamin D is decreased in elderly, lesser exposure to sunlight especially in institutionalised and homebound, and some evidence suggests decreased capacity of aging kidney

to convert vitamin D to the active  $1,25(\text{OH})_2\text{D}_3$  form so elderly women might develop deficiency of vitamin D. Vitamin D supplementation of 400 IU/day might be required. Lack of calcium and Vitamin D would result in osteoporosis and osteomalacia. But most of the elderly use more of vitamins than required and that should always be looked into.

### *Water*

Proper fluid intake is very important for the elderly. Dehydration is most common cause of fluid and electrolyte disturbances and can be because of:

- Reduces thirst sensation and diminished fluid intake
- Diminished water conservation by kidneys
- Use of diuretics
- Diarrhoea or fever
- Incontinent patients

So all these conditions must be monitored for proper fluid intake by the elderly.

## Conclusion

For health from adolescent to menopause if we can do some life style modifications like increasing our daily routine activities, reducing sedentary life style and making exercise an integral part of our life then it would go a long way in keeping us fit and our weight would be under control our diet should be roughly like the pyramid shown here:

- Our diet should have basically more of whole grains that is why we put them on the base of the pyramid. Oat meal, brown rice and whole wheat have low glycaemic index, so they should be used more often.
- *Oils*: They should be mainly from vegetable oils like canola, soya oil, sunflower oil, peanut oil. What ever recommended daily requirements should not be substituted by carbohydrates.
- *Vegetables and fruits*: There should be three helpings of vegetables daily with 2-3 helpings of fresh fruits to give us our all vitamins, antioxidants and iron. They should be of different colors to add variability and taste.
- Fish poultry and eggs to give us proteins and DHA a type of LCPUFAs
- *Nuts and legumes*: They are the source of fibre, protein, vitamins, minerals and fats. Daily 1-3 helpings are needed.

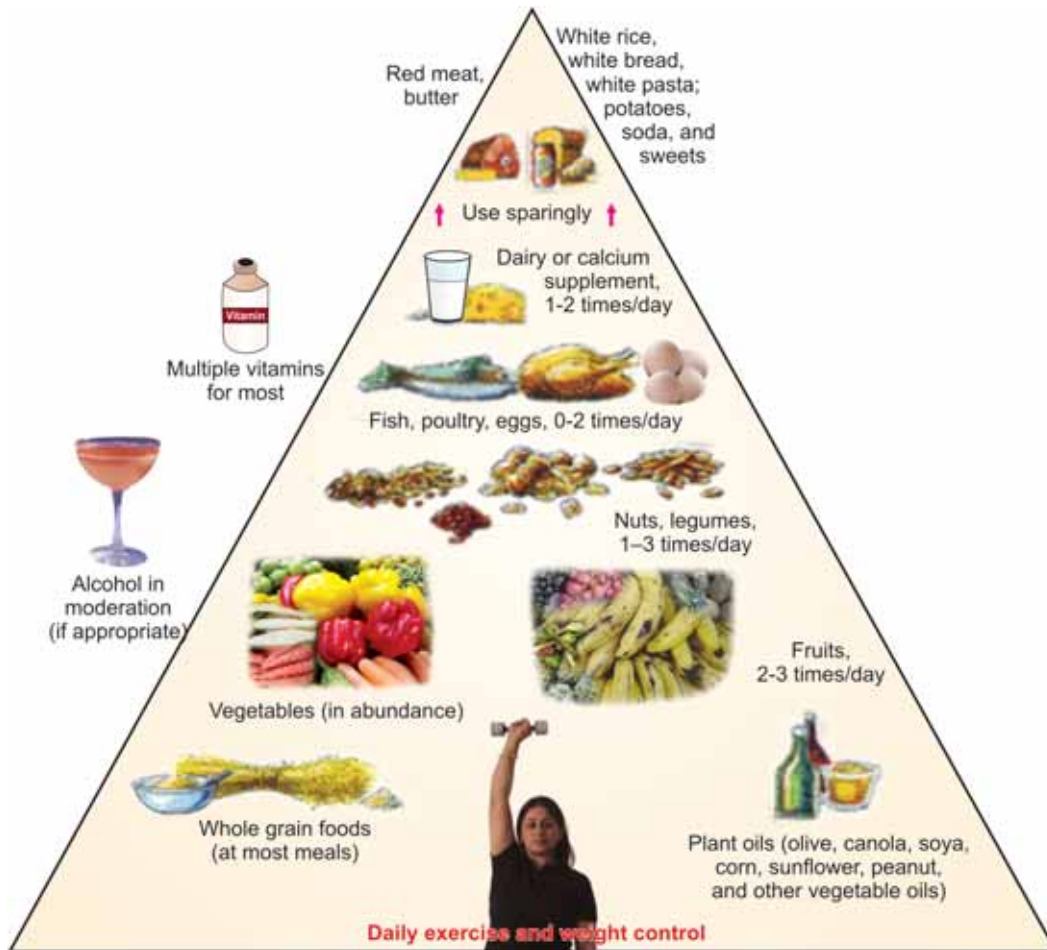


Fig. 57.7: Eat and exercise pyramid

- Milk as a source of calcium is very essential for proper development of bones. 1 cup of milk gives 300 mg of calcium. It can be consumed as milk products also as yoghurt with fruit would make an ideal dessert. Always take low fat milk and milk products
- Red meat and butter should be in minimum quantity
- Alcohol in moderation just 1-2 drinks.
- Pasta, white bread, potatoes, white rice, sweets, aerated cold drinks should be used sparingly as they add to empty calories in the body.

Active Muscle Exercises	946	Short-wave Therapy	951
Electrical Stimulation of Pelvic Muscles	947	Infrared Radiation	952
Supporting Pessaries	948	Transcutaneous Electric Nerve Stimulation (TENS)	952
Vaginal Packing-tamponade	950	Ultrasound	952
Douching	951		

## ACTIVE MUSCLE EXERCISES

Regular physical exercise is essential to health. Provided she maintains a good posture, a woman ordinarily has no need for specially planned exercises because the movements carried out in the course of polishing, bending, lifting and running up and down stairs could hardly be improved upon. The woman unoccupied in this way, and doing sedentary work in factory or office, should be encouraged to take up other activities such as games, dancing, gardening and walking. If she has no other opportunities she can at least walk part of the way to work. The only muscles not exercised routinely in the course of domestic chores are those of the lower abdomen.

The pursuit of physical exercise may be of curative as well as prophylactic value in the treatment of certain cases of dysmenorrhoea, premenstrual syndrome, climacteric symptoms, constipation and other disorders with a background of introspection and overanxiety. It disciplines the mind as well as the body and satisfies the self.

## Postnatal Exercises

Day-to-day activities, together with walking, are valuable during pregnancy. They help to make the muscles strong and supple, prevent constipation and varicose veins, preserve posture, and ensure a quick return to health after delivery. The need for exercises during pregnancy is questionable although they assist in giving the woman confidence and quietness of mind and train her in the correct method of bearing down. Whatever view may be taken about these, the value of exercises during the puerperium is definite. Their objectives are: preservation or restoration of normal bladder and bowel functions; full expansion of the lungs after pregnancy and anaesthesia; maintenance of the circulation to reduce the risk of thrombosis and embolism; restoration of muscle tone, figure and posture; rapid and complete involution of pelvic organs and their supports; and prevention of prolapse.

Postnatal exercises are introduced gradually, commencing on the first day after delivery and continued for at least 3 months. Their exact details vary from clinic to clinic but, in principle, they help to return the pelvic floor and the abdominal wall as near as possible to the pre-pregnancy state. They consist of the following:

- Attention to posture when sitting, standing and walking.
- Deep breathing - inspiration and expiration.
- Arm, leg and foot movements of flexion, extension and rotation.
- Quadriiceps drill.
- Rotation, flexion and extension movements of the trunk.
- Movement of the legs as in cycling, with the patient lying on her back.
- Instruction in how to lift the baby or other heavy objects without bending and injuring the back.

### Pelvic Floor Exercises

These can be carried out while the patient is lying, standing or sitting; they aim to strengthen the levatores ani and the pubococcygeal muscles. The woman is instructed to lift the anus and pelvic floor as she does at the conclusion of defaecation, or she can be told to imagine that she is voiding urine and then to go through the motion of interrupting the stream suddenly. The 'squeeze' is maintained for 10-12 seconds, then relaxed for 15 seconds. The process is repeated 15 to 20 times in one session, one to three sessions a day. When giving instructions the attendant should examine the patient vaginally to ensure that she is contracting the right muscles. The grip of the levatores around the vagina is easily felt. The con-current contraction of the gluteus maximus can also be perceived by a hand placed gently on the buttock. In order to encourage her to make stronger efforts, and to assure her that she is doing the right exercise, it can be of help to give her a Kegel's perineometer (Fig. 58.1). This consists of a vaginal obturator with an air-containing sleeve connected to a manometer which measures the squeeze of the vaginal muscles. Vaginal cones of increasing weight have also been developed to assist the patient in biofeedback.

By pelvic floor exercises carried out for several months, a woman can develop considerable power in the muscles, and can learn to control minor degrees of prolapse and urethral incompetence.



Fig. 58.1: Kegel's perineometer for pelvic floor exercises

### Preoperative Physiotherapy

Preoperative chest physiotherapy is especially beneficial in women with chronic lung disease, obesity, large abdominal tumours or massive ascites which can embarrass respiration, and in smokers. Deep breathing exercises can be better taught at this time. Devices such as the incentive spirometer are useful in high-risk cases as they demonstrate the depth of the breath taken and allow the patient to judge adequacy and improvement herself.

### Postoperative Exercises

These should be carried out each morning and evening, commencing with simple manoeuvres such as deep breathing and leg and arm movements on the first day after operation. Thereafter the exercises are graduated according to the patient's speed of recovery. They are the same in principle as those advised for the postnatal period, with omissions and modifications according to the operation site. Deep breathing encourages expansion of the lungs, prevents atelectasis and improves venous return. Limb movements also help in preventing venous stasis and deep vein thrombosis.

### ELECTRICAL STIMULATION OF PELVIC MUSCLES

Much work has been done on devising means for providing continuous or intermittent electrical

stimulation of pelvic muscles. These are energised by a small generator attached to and controlled by the patient; their aim is the relief of faecal and urinary incontinence not caused by fistulas, and when surgery has failed.

By such means it is certainly possible to induce strong contractions of the voluntary muscles of the pelvic floor, including the external sphincters of the anus and urethra. So rectal prolapse and faecal incontinence can be controlled to some extent. Stress incontinence of urine is, however, not benefited, probably because the involuntary internal sphincter is not stimulated or, if it is, simultaneous stimulation of the bladder detrusor muscle (which is continuous with this sphincter) also occurs to counteract the effect.

### SUPPORTING PESSARIES

These are mechanical devices for correcting and controlling displacements of the uterus and vagina. Hundreds of different kinds have been devised through the centuries but only a few are now in general use; of these the simplest are the best. Choice of pessary depends to some extent on fashion and custom in different centres and clinics.

#### Ring Pessaries

In the past, the most commonly used rings were made of, or covered with, rubber. These are now supplanted by rings made of inert medical-grade plastic and silicon which can be autoclaved, are much less irritant to the vagina and do not absorb secretions and odours (Fig. 58.2).

When in place the ring lies around the cervix but slopes slightly downwards, the upper rim being in the posterior fornix. It is mainly used to control prolapse and acts by distending the upper vagina to make it so wide that it cannot fall through the lower vagina and introitus. Rings are graded by their overall diameters in millimetres. The correct size in any particular case is determined by trial and error but is governed mainly by the *length* of the vagina. The ring must be so large that it will not escape through the introitus when the patient strains or coughs, yet it must not fit so tightly that it cannot be rotated within the vagina by the examining fingers. The distance between the lower rim and the urethral orifice should be at least the width of a finger. Once it is in place the patient should not be conscious of the presence of a pessary.

If the ring is too small, or if the perineum is too weak, the pessary becomes displaced and slips out. Various modifications have been devised.

One modification is to fit a rigid ring (or other shaped) pessary with a short central stalk running at right angles to produce a mushroom-shaped object, e.g. the rigid Gellhorn pessary. The stalk prevents the pessary from turning on its axis in the vagina and allows a more secure fit in certain cases.

When the introitus gapes so much that it will not contain any kind of pessary, the instrument can be kept in place by using a doughnut-shaped pessary. A latex rubber inflatable doughnut pessary is available which can be used in exceptionally severe cases. Sometimes the introitus may have to be tightened surgically under local anaesthesia to permit retention of the pessary.

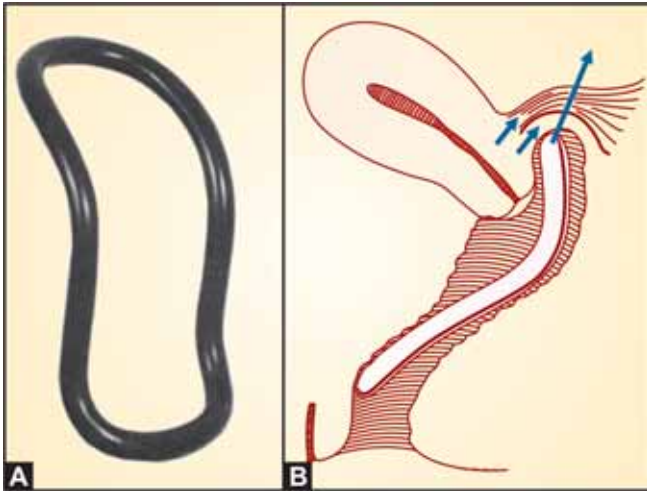
#### Hodge Pessary

The Hodge pessary is a rigid pessary made of vulcanite or silastic. The side walls are parallel, the upper end is rounded and the lower end square. It has a broader anterior limb. When viewed from the side it is curved as shown in Figs 58.3A and B. The size is according to the overall measurement from top to bottom.

The upper end of the Hodge pessary lies in the posterior fornix with its concavity facing the cervix. The lower end rests against the anterior vaginal wall and should be at least one finger's breadth above the urethral orifice. The pessary is only supported when the lower



Fig. 58.2: Plastic ring pessary used mainly to control genital prolapse when operation is ruled out



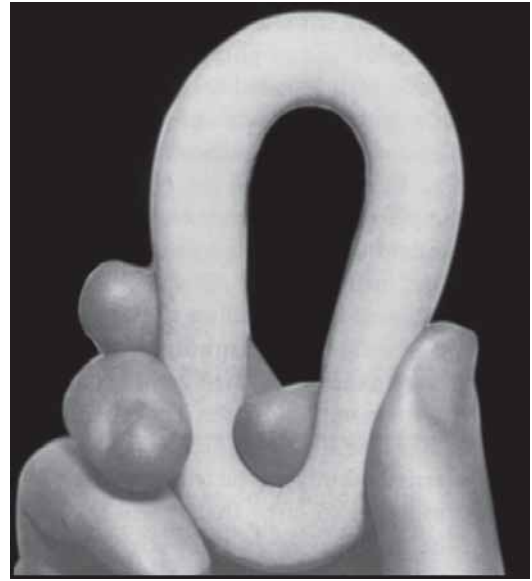
**Figs 58.3A and B:** (A) The Hodge pessary made of vulcanite or plastic material, (B) Diagrammatic explanation of the action whereby this device keeps the uterus anteverted

bar presses well into the anterior vaginal wall and into the narrow part of the subpubic angle. It is normally kept in this position by a strong perineum so, when the pelvic floor is relaxed and the introitus open, the lower end tends to move backwards into the wide part of the subpubic angle and the pessary falls out.

The Hodge pessary is the prototype of the lever pessaries. It is mainly used for prolapse with uterine retroversion and as a preoperative diagnostic aid. It does not press on the uterine fundus but acts by putting an upward and backward thrust on the posterior fornix and overlying uterosacral ligaments. This holds the cervix backwards and the fundus therefore remains forwards (Fig. 58.3B). The Smith pessary has a narrower anterior limb for patients with a narrow pubic arch.

### Insertion and Management

Pessaries must be sterilized before use, and most modern plastic ones arrive from the makers already sterilized and separately packed. All are inserted through the long axis of the vulva, the leading edge being generously lubricated. The width of a ring pessary is temporarily reduced by squeezing; this is possible even with plastic ones, especially if they are first immersed in hot water (Fig. 58.4). Once in the vagina, the pessary turns naturally into the side-to-side plane but care is necessary to ensure that the upper rim is above and behind the cervix. One secret in reducing the momentary discomfort



**Fig. 58.4:** The method of holding a ring pessary when inserting it into the vagina (the same method is used for the vaginal diaphragm)

experienced by the patient as the ring engages the introitus is to avoid pressure against the vestibule and urethral orifice. To remove a pessary the lower rim is hooked down with the index finger.

Pessaries require to be renewed every 4-6 months (rubber ones much more frequently). The patient can sometimes be taught to change the pessary herself at frequent intervals.

No matter who is responsible for changing the device, the patient wearing a pessary needs to remain under regular medical supervision. This is to allow periodic inspection of the vagina and cervix to exclude injurious effects. The presence of inflammation or ulceration is a contraindication to the wearing of a pessary until the lesion has healed.

Plastic pessaries produce practically no local reaction so douching is unnecessary. Rubber devices, however, generally cause discharge which can be most offensive. So, they are rarely used.

### Indications

#### *Prolapse*

Ring pessaries are used to control uterine and vaginal prolapse under the circumstances described in Chapter 16.

### *Retroversion*

The best pessary for treating retroversion is the Hodge pessary. In multiparous women, however, it may not be retained and a ring has to be substituted; this is generally less effective. The circumstances under which pessary treatment might be advised for retroversion are listed in Chapter 17.

## Complications

### *Constipation*

A pessary which is so large that it presses on the rectum may cause difficulty in evacuation. On the other hand, constipation which leads to violent expulsive efforts can displace the pessary.

### *Urinary Incontinence*

A ring inserted for prolapse sometimes causes stress incontinence. This occurs mainly when the ring is too big and stretches taut the anterior vaginal wall in the region of the urethrovesical junction.

A neglected pessary causing deep ulceration can result in a vesicovaginal fistula.

### *Vaginitis, Cervicitis, Ulceration of Vaginal Wall*

These were more likely with rubber devices. Mild vaginitis causes only discharge; it is not of great consequence although it requires treatment. Severe vaginitis and ulceration lead to a heavy offensive discharge and to bleeding. These complications call for removal of the device which usually brings about a spontaneous cure but healing may require specific therapy.

### *Carcinoma of the Vaginal Wall*

This may occur when traumatic ulceration is neglected. It tends to have an annular distribution. Because of this statistically small risk it is sometimes said that pessaries should never be used for prolapse. This extreme view is unjustified. There are circumstances when mechanical control of the prolapsed tissues, sometimes for limited periods of time as during pregnancy, is the only means of giving the woman relief.

For old women, physically or mentally unfit, a pessary control of prolapse can be a 'God-send'.

### *Impaction of the Pessary*

If the pessary is left unchanged for years, it may become impossible to remove it except by operation. This sometimes happens in forgetful or careless old women who develop senile contracture of the tissues lying below the level of the ring. It can also result when the vaginal wall ulcerates and then heals to form a bridge *within* the rim of the pessary (*see* Chapter 15).

### *Strangulation of Prolapsed Tissue*

This, within a rigid ring, is also described as a rare complication.

## VAGINAL PACKING-TAMPONADE

Packing the vagina with a gauze strip, cotton wool or similar absorbent material is sometimes called tamponade, the object inserted being a tampon.

### Indications

- To contain the normal menstrual discharge.
- To stop oozing at the end of an operation on the vagina or cervix.
- To arrest secondary postoperative haemorrhage from the vaginal walls and cervix. It should *not* be used for primary postoperative haemorrhage.
- To convey medication to the vagina and cervix.
- To control uterovaginal prolapse complicated by decubital ulceration. The tampon acts by establishing a normal circulation in the tissues and this allows spontaneous healing. The application of oestrogen cream to the packing in decubital ulceration, prior to vaginal hysterectomy, may also be helpful.

### Method

Proprietary tampons may be encased in a rigid container which allows their easy insertion; an attached string permits their removal. Unless these are used the vagina is generally best packed with one continuous strip of gauze, the end being left protruding. If more than one pack or if pledgets of cotton wool are inserted, a careful count must be made and recorded to ensure that all are later removed.

Ordinarily, vaginal tampons are not left in place for longer than 24 hours because they become infected and



offensive. Sometimes—for haemorrhage for example—it may be wise to leave them unchanged for 48-72 hours.

A vaginal tampon which is overlooked can cause troublesome infection which may ascend to involve the tubes and peritoneum, or the toxic shock syndrome may develop (see Chapter 5). In practice, however, it is rare for serious consequences to occur before the profuse offensive discharge leads to the tampon's discovery.

## DOUCHING

### Types of Douches

#### *Cleansing*

The *normal* woman does *not* require to wash out the vagina at any time and should be advised against it. Douching should also be avoided in cases of true leucorrhoea (see Chapter 42). It dissolves and removes the mucoid discharge of the cervix but it has the disadvantage of upsetting the normal vaginal acidity which can then predispose the woman to reproductive tract infections.

#### *Antiseptic*

Antiseptic douches may be indicated when there is a purulent discharge associated with infection in the vagina and cervix, especially when it occurs around incisions and tears, or for haemorrhage after operations on the vagina and cervix. Examples are acriflavine 1 in 1000 and povidone iodine solutions. Douching, however, is not a very efficient way of applying antiseptics and, if carried out by the patient, involves the risk of too strong a solution being used. Severe chemical burns of the vagina have occurred as a result (see Fig. 38.3).

### Methods

Douching is most efficient when the woman lies flat in a bath. In practice, when treating herself, she usually sits on a WC, bidet or bedpan. For the sick woman in bed, attended by a nurse, the lateral or the dorsal position can be used.

#### *Douche Can*

The safest and best method is to run the fluid from a douche can or bag suspended not higher than 60 cm above the vagina. The tube from this leads into a blunt-

ended metal or plastic nozzle which is inserted into the upper vagina. The fluid is allowed to flow slowly by gravity for a period of 5-10 minutes in the case of a long douche; a shorter time is appropriate for the cleansing 'wash out'. Escape of fluid can be impeded from time to time by closing the vulva with the hand, and this has the effect of ballooning the vagina to open up the rugae.

#### *Syringe or Whirling Spray*

The danger of this method is that too much pressure may force fluid and air into the uterus and peritoneal cavity. Air embolism is a real risk - especially during or just before menstruation, and during pregnancy. There is also a risk of introducing infection into the upper genital tract.

## SHORT-WAVE THERAPY

Short-wave therapy aims to raise the temperature of deeply situated tissues and to induce hyperaemia. This in turn promotes natural resistance to infection and encourages resolution of inflammatory processes as also the elimination of metabolic waste products.

### Indications

Short-wave therapy can easily become a quack remedy, soothing to the mind rather than the body of the patient. It has been, and is, used in the treatment of almost all 'female complaints', and claims are made for its value in conditions such as dysmenorrhoea, cervical erosion, infertility and pelvic pain. All such claims are without scientific foundation.

The only acceptable indications for short-wave therapy are:

- Subacute and chronic cellulitis;
- Subacute and chronic salpingo-oophoritis; and
- Late radiation effects characterised by ischaemia of the tissues in and around the vagina, uterus, bladder and rectum.

Short-wave therapy should not be used during the *acute* stages of pelvic inflammatory disease, nor in cases of tuberculous infection. In both these circumstances it is likely to cause an exacerbation of the problem. When a patient believed to have chronic pyogenic salpingo-oophoritis fails to respond, or it gets worse after treatment, the diagnosis should be reviewed with the possibilities of endometriosis and tuberculosis in mind.

## Techniques

Treatment is given every alternate day for a total of 15-18 exposures. The patient may lie on a couch or be semirecumbent in a special chair. Electrodes are placed on the lower abdomen and back and sometimes on the flexed thighs. The dose is small at first and is gradually increased according to the patient's reactions and progress.

## Results

Usually the patient suffering from chronic pelvic infection gets relief of pain during treatment but some pain may persist for a short time afterwards. During the course of days or weeks the inflammatory reaction in the pelvis tends to subside, masses get smaller and organs become less tender and fixed. This, however, is the natural history of pelvic inflammatory disease and it is always difficult to decide how far pelvic heat assists spontaneous resolution.

## INFRARED RADIATION

Infrared rays are electromagnetic waves with wavelength of 750 nm to 400000 nm. The penetration is only up to the deeper epidermis. They help in pain relief and muscle relaxation in much the same way as short-wave diathermy and are effective in relieving the pain of episiotomies and abdominal wounds.

## TRANSCUTANEOUS ELECTRIC NERVE STIMULATION (TENS)

TENS is a method of electroanalgesia which stimulates the large-diameter afferent sensory fibres and produces an anti-nociceptive effect at the spinal or supraspinal level. It also decreases ischaemia by improving the blood flow and probably decreases the oxygen consumption. The latter effect is thought to be mediated by enkephalins,  $\beta$ -endorphins and dynorphins which are synthesised locally and which may serve a paracrine function. A segmental decrease in sympathetic activity may also contribute to decreased local oxygen consumption.

## Indications

TENS is ineffective for visceral pain of neurogenic and musculoskeletal origin, but is useful if the pain is secondary to local ischaemia as in severe primary dysmenorrhoea and in some cases of chronic pelvic pain. It is used alone or as adjuvant therapy to conventional pharmacological methods.

## Technique

Commercially available TENS stimulators deliver current at 0.2 ms at a frequency of about 70 to 100 Hz. Electrodes applied to the lower abdomen and sacroiliac region deliver a high-intensity stimulation of 40 to 50 mA which can be decreased if it causes discomfort.

## Results

About 90 per cent of patients report some degree of relief while about 30 per cent report significant relief with the addition of TENS.

## ULTRASOUND

Ultrasound is now widely used to treat a variety of traumatic and inflammatory conditions, and is used in obstetrics and gynaecology to treat early episiotomy scars, and also scars of long standing, including those of episiotomy, caesarean section and hysterectomy.

In the treatment of early (i.e. first day) episiotomy scars, the absorption of fluid is promoted and the formation of adhesions is reduced. The analgesic effect gives the patient relief from pain and discomfort, and increased blood supply aids tissue repair.

Long-standing scars, of whatever nature, are softened by the application of ultrasound, and it is of value both for superficial scars and others, up to a depth of approximately 3 cm, including induration following a haematoma.

Therapeutic ultrasound is administered through a transducer head which is kept moving and in contact with the part to be treated by means of a coupling gel, water bag or immersion in water. This ensures maximum contact and therefore maximum absorption. The device can be either pulsed or continuous, according to the depth of the area to be treated and the effect to be achieved.

# Index

## A

- Abdominal myomectomy 497
- Abdominal pregnancy 157
  - diagnosis 158
  - pathology 157
  - treatment 158
- Abnormal and excessive uterine bleeding 598
  - causes 599
    - anovulatory bleeding 604
    - coagulation defects 599
    - deep venous thrombosis 603
    - dysfunctional uterine bleeding 603
    - general systemic diseases 599
    - ovulatory bleeding 604
    - pelvic pathology 599
    - psychological upsets 603
    - tumours 601
    - uterine 601
  - clinical examination 606
  - diagnosis 605
  - haematological and endocrine evaluation 606
  - treatment 607
- Abnormal menopause 99
  - artificial menopause and climacteric 100
    - radiation menopause 100
    - surgical menopause 100
  - follicle stimulating hormone (FSH) and luteinizing hormone (LH) in a menopausal woman 100
  - follicle-stimulating hormone 100
  - late menopause 99
  - luteinizing hormone 100
  - premature menopause 99
- Acquired atresia and stenosis of the genital tract 268
  - causes 270
  - effects 273
  - infections and epithelial disorders 271
  - operative and other injuries 270
  - pathology 268
  - radiotherapy 271
  - treatment 273
- Actinomycosis 331
- Active muscle exercises 946
  - pelvic floor exercises 947
  - postnatal exercises 946
  - postoperative exercises 947
  - preoperative physiotherapy 947
- Adenomyosis 381
  - clinical features 382
  - diagnosis 382
  - mechanism of origin 381
  - pathology 381
  - treatment 382
    - medical 382
    - palliative 382
- Adolescents nutrition 931
- Adult respiratory distress syndrome (ARDS) 923
- Aftermath of hysterectomy 889
- Amenorrhoea 579
  - aetiology 579
    - pathological amenorrhoea 580
    - physiological amenorrhoea 579
  - endocrine disorders 587
  - environment 590
  - exercise-related amenorrhoea 590
  - general constitutional upset and disease 587
  - hormone therapy 593
  - investigation 590
  - special investigations 591
  - therapeutic tests 592
  - treatment 592
  - types 579
    - false amenorrhoea 579
    - true amenorrhoea 579
- Amoebiasis 332
- Anatomy 21
  - fallopian tubes 34
    - general description 34
    - relations 35
    - structure 34
    - vascular connections and innervation 35
  - features of each part of the uterus 30
    - cervix 31
    - corpus (including fundus) 30
    - isthmus 31
  - individual structures 21
    - clitoris 22
    - hymen 23
    - labia minora 22
    - mons veneris and labia majora 1
    - perineum 22
    - vestibular bulb 23
    - vestibule 23
  - ovary 36
    - changes with age and parity 36
    - general description 36
    - relations 36
    - structure 36
    - vascular connections 37
  - pelvic fascia and cellular tissue 45
    - pubocervical fascia 46
    - transverse cervical 45
    - uterosacral ligament 45
  - pelvic peritoneum and ligaments 43
    - broad ligament 44
    - iliococcygeus 45
    - ischiococcygeus (coccygeus) 45
    - levator ani 45

- ovarian ligament 44
- pelvic musculature 44
- pelvic part of piriformis muscle 45
- peritoneal pouches 43
- pubococcygeus 45
- round ligament 44
- uterosacral ligament 44
- rectum and anus 42
  - general description 42
  - relations 42
  - structure 42
  - vascular connections 43
- sigmoid colon 41
  - general description
  - relations 42
  - structure 41
  - vascular connections 42
- ureter 41
  - general description 41
  - relations 41
  - vascular connections 41
- urethra and bladder 37
  - general description 37
  - relations of the urethra and bladder 40
  - structure 37
  - vascular connections 40
- uterus 30
  - general description 30
  - structure 30
- vagina 25
  - general description 25
  - structure 26
- vascular connections 33
  - arterial 33
  - lymphatic 34
  - venous 33
- vulva 21
- Androgens in menopause 882
- Apareunia and dyspareunia 685
  - diagnosis 687
  - female causes 686
  - male causes 686
  - obstruction at the introitus 686
  - treatment 688
- Assessment of response to chemotherapy 562
- Assisted reproductive technology (ART) 721
  - donor insemination (DI) 725
  - intrauterine insemination (IUI) 724
  - other ART methods 726
- Autosomal intersex 230
  - constitutional hirsutism 230
  - testicular feminizing syndrome 231
- B**
- Backward displacement of the uterus 294
  - causes 295
    - developmental 295
    - prolapse 295
    - puerperal 295
  - differential diagnosis 297
  - management and treatment 297
  - physical signs 296
  - prevention 297
  - symptoms 296
    - abortion 296
    - dyspareunia 296
    - infertility 296
    - low backache and pelvic pain 296
  - pelvic congestion syndrome 296
  - rectal symptoms 296
  - spasmodic dysmenorrhoea 296
- Bartholin's glands 21
- Bartholinitis 338
  - aetiology 338
  - clinical features 338
  - pathology 338
  - treatment 338
- Benign breast disease 184, 186
  - screening mammography 184
  - screening strategy 184
- Biological basis of radiotherapy treatment 568
- Blood vessels of the pelvis 47
  - arteries 47
    - common iliac artery 47
    - external iliac artery 47
    - internal iliac artery 48
    - internal pudendal artery 50
    - ovarian artery 47
    - uterine artery 49
    - vaginal artery 49
- Bone loss (osteoporosis) and fracture risk 871
- Bone mineral density (BMD) 812
- Boney's myomectomy clamp 735
- Brachytherapy 569
- Brachytherapy in carcinoma cervix 571
- Breast development 174
  - endocrine control of female breast 175
  - stages of breast development of puberty 174
  - Tanner's staging 175
- Broad ligament haematoma 261
  - causes 261
  - clinical features 261
  - pathology 261
  - treatment 261
- C**
- Cancer screening in menopause 877
- Carbohydrates 929
- Cell-kill hypothesis 563
- Cervical atresia 205
- Cervical cycle 86
- Cervical endometriosis 383
- Cervical pregnancy 157
- Cervicitis 347
  - acute cervicitis 347
  - chronic cervicitis 347
- Cervix 410
  - cervical intraepithelial neoplasia 413
    - diagnosis 415
    - pathology 414
    - treatment 420
  - ectopy 410
    - aetiology 410
    - pathology 410
    - physical signs and diagnosis 411
    - symptoms 411
  - squamous cell hyperplasia 413
  - squamous metaplasia 412
- Chemoradiation in locally advanced carcinoma cervix 571
- Chemotherapy and the cell cycle 562
- Chemotherapy resistance of cancer cells 566
- Chromosomal sex 221
  - chimaerism and dispermy 223
  - chromosomal sex drive 224
  - division and distribution 222
  - errors in sex chromosome 222
  - ovotestis 224
  - sex chromatin pattern 223
  - streak gonads, gonadal aplasia and hypoplasia 226
- Chronic ectopic pregnancy 148
  - acute clinical picture 149
  - classical triad 149
  - diagnosis 150
  - differential diagnosis 149
  - laboratory tests 152

- tests and aids to diagnosis 150
  - treatment 152
  - Clinical use of chemotherapy 562
  - Coital difficulties in the male 692
  - Colour Doppler 14
  - Complete perineal tear 256
    - pathology 256
    - result 257
    - symptoms 256
    - treatment 256
  - Computed tomography 19
  - Contraception 784
    - adverse effects and complications of IUCDs 799
    - barrier methods 789
    - combined hormonal contraception 801
    - future IUCDs 796
    - general consideration 784
      - efficacy of contraception 785
      - epidemiology 784
      - impact of contraception throughout world 785
      - indications of contraception 786
    - hormone releasing IUCDs 796
    - intrauterine contraceptive device (IUCD) 794
    - lactational amenorrhoea method (LAM) 788
    - natural family planning method 787
    - types of IUCDs 795
      - medicated IUCDs 795
      - unmedicated or inert IUCDs 795
  - Correlation of endometrial and ovarian cycles 82
  - Curettage or endometrial aspiration 497
  - Cyclical changes in the tube 86
  - Cyclical haemothorax and pneumothorax 634
    - cyclical haemothorax 634
    - cyclical pneumothorax 634
- D**
- Deep venous thrombosis 915
  - Defective or deficient perineum 255
    - pathology 255
    - symptoms 255
    - treatment 255
  - Development of the urogenital system 189
    - bladder and urethra 194
    - development of the vagina 194
    - development of the vulva 194
    - gonad 189
    - mesenteries and ligaments 193
    - müllerian ducts 191
    - wolffian system 190
  - Developmental anomalies of breast 176
  - Difficult evacuation 893
    - causes 893
    - pregnancy and puerperium 893
    - treatment 893
  - Direct trauma to vulva and vagina 254
    - abrasions from clothing 254
    - cuts and lacerations 254
    - haematoma of the vulva and vagina 254
  - Diseases of the cervix 756
  - Diseases of the endometrium 747
  - Diseases of the uterine cavity 747
  - Distension or retention cysts 524
    - pathology 525
    - symptoms 526
      - corpus luteum cysts 527
      - luteoma of pregnancy 527
      - menstrual disturbance 526
    - types 525
      - atretic cysts 525
      - follicular and theca lutein cysts 525
      - germinal inclusion cysts 525
  - Douching 951
  - Drugs and lactation 179
  - Dysmenorrhoea 617
    - primary dysmenorrhoea 617
      - aetiology 618
      - clinical features 619
      - other factors 618
      - prevention 619
      - surgical treatment 621
      - prostaglandins 618
      - treatment 619
    - secondary dysmenorrhoea 622
      - aetiology 622
      - clinical features 623
      - investigations 624
      - treatment 624
- E**
- Early development of the ovum 123
  - Ectopic pregnancy 142
    - aetiology (causes) 143
    - assisted reproduction techniques 144
    - salpingitis isthymica nodosa 144
    - sites 142
    - smoking 144
    - tubal surgery 144
    - use of IUCD's 143
  - Ectopic pregnancy in fallopian tubes 145
    - chronic ectopic adnexal mass 147
    - clinical features 147
    - foetal survival to term 147
    - general reactions 146
    - pregnancy outcome 146
    - reactions of the tube 145
    - reactions of the uterus 145
    - sites 145
    - symptoms and signs 148
    - tubal rupture 147
  - Electrical stimulation of pelvic muscles 947
  - Embolotherapy 499
  - Emergency postcoital contraception (morning after pills) 818
    - centchroman 820
    - choice of contraception 821
    - combined oestrogen and progestogen pills 819
    - immunological method 821
    - levonorgestrel only pills 819
    - male contraceptive pill 821
    - mechanical emergency contraception 820
    - oral contraception 822
    - other methods of contraception 820
      - hormone agonist and antagonist 820
      - mifepristone (progesterone antagonist) 820
    - postpartum IUCD 822
  - Endocrine disorders (galactorrhoea and breast atrophy) 179
    - breast atrophy 182
      - classification 182
      - clinical features and evaluation 182
      - laboratory tests 183
    - causes of galactorrhoea 180
      - clinical features 181
      - diagnosis 181
      - tables of levels 181
    - galactorrhoea 179
    - management 183
    - pathophysiology of galactorrhoea 180
    - treatment 182
  - Endometrial cycle 79
    - proliferative phase 79
    - secretory phase 81

Endometrial sampling procedures 12  
 culdocentesis and culdotomy 13  
 curettage 13  
 endometrial aspiration 13  
 endometrial biopsy 12  
 hysterosalpingography 13  
 tubal patency tests 13  
 ultrasonography 14

Endometriosis 365, 349  
 acute endometritis 349  
 adenomyosis 365  
 aetiology 368  
 chronic endometritis 349  
 combined medical and surgical therapy 380  
 diagnosis 374  
 extrauterine endometriosis 365  
 general considerations 365  
 general pathological considerations 366  
 hormone therapy 378  
 oestrogens and prostaglandins 369  
 other symptoms 374  
 physical signs 374  
 progestogens 378  
 retroversion 370  
 symptoms 373  
 treatment 376  
     expectant 376  
     medical treatment 378  
     surgery 376

Endosalpingiosis 383  
 Endoscopy 16  
 Errors arising in connection with the cloaca 216

**F**

Fallopian tube 209, 426

Female frigidity 688  
 failure to achieve orgasm 691  
     aetiology 691  
     treatment 691

true frigidity—absence of libido 689  
 aetiology 689  
 constitutional 689  
 contraception 690  
 early impressions 689  
 fear 690  
 infertility 690  
 lack of deep affection of husband 689  
 physiological 689  
 prolonged separation from her male 690

systemic disease 690  
 treatment 690

Female sterilisation 825  
 adverse effects of tubal resection 828  
     immediate 828  
     remote 828  
 contraindications 827  
 laparoscopic sterilisation 826  
 obstructing the tubes via the uterus 827  
 reliability 827  
 techniques 825

Fertility and oral contraception 807  
 Fertilization of the ovum 120  
 Foreign bodies in the genital tract 251  
     other organs and tissues 253  
     uterus 252  
     vagina 251

Formation of foetus and membranes 125  
 Forward displacement of the uterus 294

**G**

Gartner's duct 521  
 General management of the cancer patient 433  
 Genital cancers 427  
     importance 427  
     treatment and results 427

Genital tract fistulas 261  
     causes 262  
     clinical features 263  
     diagnosis 263  
     treatment 263

Types 261  
     faecal 262  
     tubointestinal 262  
     uterointestinal 262  
     vaginointestinal, perineointestinal 262  
     vaginoperineal 262

Genital tuberculosis 323, 361  
     aetiology 323  
     clinical features 326  
     diagnosis 327  
     pathology and bacteriology 323  
     treatment 329

Gestational trophoblastic disorders 765  
 Gonadal intersex 231  
     organizing power of the gonad 231  
     types 231  
         female hermaphroditism 231  
         male hermaphroditism 231  
         true hermaphroditism 231

Gonadotrophin therapy 392  
 Gynaecological procedures 738  
     cervical punch biopsy 739  
     colposcopy 740  
     endometrial biopsy 739  
     hysteroscopy 739  
     speculum examination 738  
     vaginal examination 738

**H**

High-grade stromal sarcoma 513  
 Hirsutism 390, 394  
     aetiology 395  
     diagnosis of hyperandrogenism 397  
     history and physical examination 397  
     laboratory evaluation 398  
     treatment 398

late-onset adrenal hyperplasia 399  
 androgen-producing ovarian or adrenal tumours 399  
     Cushing syndrome 399  
     idiopathic hirsutism 399  
     virilisation and masculinisation 394

Homosexuality 695  
 Hormonal control of early pregnancy 128  
     corpus luteum of pregnancy 128  
     gonadotrophins 129  
     human placental lactogen (HPL) 129  
     placental hormones, enzymes and proteins 128  
     progesterone 129

Hormonal intersex 232  
     combinations of chromosomal, genetic and gonadal causes of intersex 237  
     congenital adrenal hyperplasia 233

Hormone levels and assay 77  
 Hormone therapy 637  
     androgens 647  
         action in the male 648  
         actions in the female 648  
         biological actions 648  
         therapeutic applications 649  
         types and sources 647  
     antiandrogens 650  
     antigonadotrophins 652  
         actions 652  
         GnRH agonists 652  
         GnRH antagonists 652  
         indications 653  
         therapeutic applications 653  
     anti-oestrogens 644

- antiprogestogens 647  
hypothalamic hormones 654  
  actions 655  
  diagnostic applications 655  
  types and sources 654  
oestrogens 637  
  adverse effects 642  
  contraindications 643  
  methods of administration 638  
  natural oestrogens 637  
  synthetic oestrogens 637  
  therapeutic applications 638  
progestogens 644  
  actions 645  
  adverse effects 646  
  endometriosis 646  
  indications 645  
  pelvic cancer 646  
  therapeutic applications 645  
  types and sources 644  
types of gonadotrophins 650  
  adverse effects 652  
  chorionic gonadotrophins 651  
  pituitary gonadotrophins 650  
  recombinant gonadotrophins 651  
  therapeutic applications 651
- Hydatidiform mole 162  
  clinical features 164  
  contraception 167  
  diagnosis 165  
  incidence 162  
  pathology 162  
  treatment 165
- Hypomenorrhoea 595  
  causes 595  
    constitutional 595  
    hormonal 596  
    nervous and emotional 596  
  treatment 596  
  uterine 595
- Hysterectomy 499, 884  
  advantages 885  
  disadvantages 885  
  panhysterectomy 885  
  radical hysterectomy 885  
  types 884  
    subtotal hysterectomy 884  
    total hysterectomy 884
- Hysteroscopy 18, 778  
  advantages 778  
  ancillary equipment 780  
  contraindications 779  
  disadvantages 779  
  distension media 780  
  equipment 779  
  fluid delivery systems 780  
  indications 779  
  technique 781
- I**
- Immunotherapy 573  
  basis of immunotherapy 573  
  types 575  
    active immunotherapy 575  
    passive immunotherapy 576
- Implantation of the ovum into the uterus 123
- Incontinence of faeces and flatus 892  
  causes 892  
  treatment 892
- Infertility 699  
  causes 700  
  investigation 703  
  treatment 715
- Innervation of pelvic organs 53  
  autonomic nerves 53  
  parasympathetic 54  
  somatic nerves 53  
  sympathetic 53
- Instruments in gynaecological surgery 731
- Intersex 219
- Intersex developing after birth 244  
  causes 247  
    diagnosis 248  
    excessive androgen stimulus 247  
    treatment 249
- feminism 244  
  causes 245  
  manifestations 244  
  treatment 245
- hormonal 250  
  antiandrogens 250  
  corticosteroids 250  
  cosmetic 250  
  GnRH agonists 250  
  medroxyprogesterone acetate 250  
  oestrogen 250  
  virilism 246
- Intraligamentary pregnancy 159
- Inversion of the uterus 300  
  acute inversion 301  
  chronic inversion 301  
    clinical features 302  
    pathology 301  
    treatment 302  
  senile inversion 302
- Irritable bowel syndrome 894  
  causes 894  
  diagnosis 894  
  treatment 894
- K**
- Karman's syringe 735  
Kegel's pelvic floor 286  
Klinefelter syndrome 229  
Kobelt's tubules 521
- L**
- Laceration of the cervix 257  
  clinical features 259  
  complications and other effects 259  
  cervical ectropion 259  
  distortion and scarring of the cervix 259  
  treatment 260  
  types and causes 257  
    obstetrical injuries 257  
    surgical injuries 259
- Laparoscopic myomectomy 499  
Laparoscopic ovarian drilling 392  
Laparoscopy 16, 767  
  advantages 767  
  ancillary instruments 770  
  complications 777  
  contraindications 768  
  diagnostic laparoscopy 773  
  disadvantages 768  
  equipment 769  
  indications 768  
  operative laparoscopy 768  
  operative laparoscopy 775  
  techniques 772
- Lateral displacement of the uterus 293  
  causes 294  
  treatment 294
- Leiomyosarcoma 513
- Low backache and chronic pelvic pain 676  
  causes in the genital tract 676  
  chronic cervicitis 677  
  gynaecological operations 677  
  prolapse and retroversion 677  
  tumours 677  
  uterine contractions 677
- extragenital causes 677  
  bone and joint lesions 678  
  diseases of the kidney and the ureter 678  
  diseases of the rectum 678

- muscular and ligamentary lesions 677
  - psychological factors 678
  - general considerations 676
  - management and treatment 678
    - chronic pelvic pain 678
    - evaluation 679
  - Low-grade stromal sarcoma 513
  - Lymphatic drainage 51
    - anus and rectum 53
    - cervix 51
    - corpus uteri 51
    - fallopian tube and ovary 51
    - sigmoid colon 53
    - urethra and bladder 52
    - vagina 51
    - vulva and perineum 51
  - M**
  - Magnetic resonance imaging 20
  - Male sterilization 828
    - compulsory sterilisation 829
    - no-scalpel vasectomy 829
    - other methods 829
    - techniques 828
  - Malformations of the urinary tract 217
  - Management of aberrations of sex present at birth 240
    - diagnosis 240
    - investigations 240
  - Management of advanced pelvic cancer 434
  - Masturbation 685
  - Meigs' syndrome 543
  - Membranous dysmenorrhoea 624
  - Menopause 862
    - effect of oestrogen deficiency 867
      - brain and central nervous system 867
    - hormonal changes with established menopause 866
    - hot flushes 867
      - management 868
      - physiology 868
      - problems associated with menopause 867
    - Physiology 864
    - Stages 862
      - early postmenopause 863
      - postmenopause 863
  - Menopause and the climacteric 91
    - cardiovascular 93
    - climacteric (menopausal) symptoms 92
    - gastrointestinal 93
    - genital and sexual 94
    - management of the menopause and of climacteric symptoms 94
    - neurotic and psychotic 93
    - osteoporosis 93
    - physical changes 91
    - psychological changes 92
    - urinary 94
  - Menstrual epilepsy 636
    - clinical features 636
    - treatment 636
  - Menstrual irregularities 389
    - skin manifestations 389
  - Menstrual migraine 630
    - aetiology 630
    - clinical features 630
    - treatment 630
      - general 630
      - hormone therapy 630
  - Menstrual problems 875
  - Menstruation 88
    - general description 88
    - artificial deferment or advancement of menstruation 90
    - general disturbances associated with menstruation 89
    - management of normal menstruation 89
  - Metastatic (secondary) ovarian tumours 557
  - Metritis 350
    - aetiology 350
    - clinical features 350
    - pathology 350
  - Mixed müllerian tumours 514
  - Monoclonal antibodies as therapeutic agents 577
    - application and uses 577
    - bispecific monoclonal antibodies 577
    - disadvantages 577
  - Monounsaturated fats (MUFA) 927
  - Müllerian duct anomalies 196
    - absence or incomplete development of both müllerian ducts 196
    - pathology 196
    - absence or incomplete development of one müllerian duct 198
      - diagnostic signs 199
      - pathology 198
      - symptoms 199
      - treatment 199
  - clinical aspects 198
  - duplication and diverticula of müllerian ducts 204
  - imperfect fusion of the müllerian ducts 199
    - arcuate uterus 200
    - bicornuate uterus 199
    - deformities in combination 200
    - pathology 199
    - septate and subseptate uterus 199
    - septate and subseptate vagina 200
    - uterus didelphys 199
  - incomplete canalization of müllerian ducts-congenital gynatresia 205
  - sites 205
- Myoma coagulation (myolysis) 499
- Myometrial cycle 86
- N**
- Natural defences of the genital tract 308
  - defence mechanisms 308
    - cervix 309
    - uterus 309
    - vagina 308
    - vulva 308
  - types of infecting organisms 309
  - variations in the efficiency of defence mechanisms 309
    - during the puerperium 309
    - with age 309
    - with menstruation 309
- Neoplasms of the pelvic ligaments and connective tissues 523
- Neoplasms of the peritoneum 523
  - mesotheliomas 523
  - peritoneal carcinomas 523
- Normal female pelvis 741
- Nutrition in women 925
- Nymphomania 691
- O**
- Obesity in adolescents 932
- Oligomenorrhoea 596
  - causes 596
    - chromosomal 597
    - constitutional and physiological 596
    - hormonal 596
  - treatment 597



- Oophoritis 356  
 aetiology 356  
 clinical features 356  
 pathology 356  
 treatment 356
- Other malignant tumours of the cervix 486
- Other sexually transmitted infections 316
- genital human papillomavirus (HPV) 319  
 clinical features 320  
 diagnosis 321  
 pathology 320  
 pathology and clinical features 319  
 treatment 321
- genital mycoplasmas 322  
 diagnosis 322  
 pathology and clinical features 322  
 treatment 322
- granuloma inguinale (donovanosis) 322  
 diagnosis 323  
 pathology 323  
 treatment 323
- human immunodeficiency virus (HIV) infection and acquired immune deficiency syndrome (AIDS) 317  
 clinical features 317  
 diagnosis 318  
 pathology 317  
 treatment 319
- lymphogranuloma venereum (LGV) 321  
 clinical features 321  
 diagnosis 322  
 treatment 322
- Ovarian and parovarian tumours and pregnancy 559  
 differential diagnosis 560  
 pathology 559  
 treatment 560
- Ovarian enlargements 524
- Ovarian functions 56  
 oestrogens 67  
 actions 68, 71  
 production 67  
 receptors 67  
 secondary sex organs 68  
 pituitary hormones 73
- anterior lobe hormones 73  
 catecholestrogens 73  
 follicle stimulating hormone 73  
 posterior lobe hormones 73
- production of ova 57  
 follicular atresia 65  
 follicular phase 59  
 luteal phase 64  
 maturation of ovum 63  
 preantral follicle 58  
 primordial follicles 58  
 rupture of the follicle  
 ovulation 63
- two-cell two-gonadotropin theory 59
- Ovarian neoplasms 528  
 clinical features 543  
 complications 548  
 connective tissue tumours 542  
 adenofibroma 542  
 fibroma 542  
 diagnosis 545
- lipoid cell tumours 538  
 germ cell tumours 538  
 germ cell tumours showing extraembryonic differentiation 540
- germ cell tumours with embryonic differentiation 538  
 mixed germ cell tumours 542
- pathology 531  
 Brenner tumour 533  
 clear cell (mesonephroid) tumours 533  
 endometrioid tumours 532  
 epithelial ovarian tumours 531  
 mucinous cystadenoma 531  
 ovarian adenocarcinoma 533  
 tumours of borderline malignancy 534  
 undifferentiated carcinoma 533
- physical signs 544  
 primary ovarian tumours 528  
 sex cord stromal tumours 534  
 androblastomas 536  
 granulosa and theca cell tumours 534  
 gynandroblastoma 538  
 sex cord mesenchymal tumour with annular tubules 538
- symptoms 544  
 Ovarian neoplasms 763
- Ovarian pregnancy 155  
 clinical features differential diagnosis 156  
 pathology 156  
 treatment 157
- Ovarian sonography 756
- Ovulation 100  
 analysis of symptoms 101  
 cyclical bleeding 101  
 endometrial changes 101  
 ovulation bleeding or discharge (mittelblüt) 101  
 ovulation pain (mittelschmerz) 101  
 premenstrual mastalgia 101  
 temperature changes 101
- changes in cervical mucus 102  
 diagnosis of symptoms 101  
 hormone assays 103  
 ovulation and lactation 101  
 ovulation and the menopause 100  
 treatment 104  
 vaginal smears 103
- P**
- Paget's disease 407  
 Pelvic allergic 633  
 Pelvic cellulitis 357  
 acute and subacute cellulitis 357  
 clinical features 358  
 diagnosis 358  
 pathology 358  
 treatment 358
- chronic cellulitis 359  
 aetiology and pathology 359  
 clinical features 359  
 diagnosis 359  
 treatment 359
- Pelvic inflammatory disease (PID) 359  
 aetiology 359  
 clinical features and diagnosis 359  
 treatment 359
- Pelvic organ prolapse 275  
 activating factors 283  
 aetiology 281  
 carcinoma of the cervix or vagina 281  
 complications 279  
 decubital ulceration 279  
 keratinization of the vagina 279  
 differential diagnosis 284  
 genital prolapse and pregnancy 281  
 hypertrophy of the cervix 280

- congestion and oedema 280
  - elongation of the supravaginal cervix 280
  - glandular hypertrophy 280
  - incarceration of the prolapse 280
  - infection of the urinary tract 280
  - obstructive lesions of the urinary tract 280
  - physical signs 284
  - posterior compartment defects 279
  - predisposing factors 281
    - congenital or developmental weakness of the supports 281
    - injury sustained during childbirth 282
  - prevention 285
  - symptoms 283
  - treatment 286
    - operative treatment 286
    - other operations 290
    - types of operation 287
  - types 276
    - uterine (uterovaginal) prolapse 276
    - vaginal prolapse 277
  - Pelvic peritonitis 356
    - aetiology 356
    - clinical features 357
    - pathology 357
    - treatment 357
  - Persistent gestational trophoblastic tumour 167
    - metastatic disease 168
      - clinical features 169
      - diagnosis 170
      - incidence 168
      - pathology 168
      - staging 170
    - non-metastatic disease 167
      - placental site trophoblastic tumour 168
    - radiotherapy 172
    - surgery 172
    - treatment 170
      - chemotherapy 170
  - Physical sex-coitus 682
    - art of coitus 682
    - consummation of marriage 683
    - frequency of coitus 683
    - coitus during menstruation 683
    - coitus during and after pregnancy 683
  - continence 684
    - annulment of marriage 684
  - Pituitary-hypothalamic relations 74
  - Polycystic ovary syndrome 384
    - clinical features biochemical, and metabolic features 386
    - pathology 385
    - pathophysiology 384
  - Polypectomy and vaginal myomectomy 497
  - Polyunsaturated fats (PUFA) 927
  - Premature orgasm 691
  - Premenstrual mastalgia 631
    - causes 631
    - clinical features 631
    - treatment 631
  - Premenstrual syndrome 627
    - aetiology 628
    - clinical features 627
    - differential diagnosis 628
    - treatment 628
  - Prevention of pelvic cancer 429
  - Prevention and management of osteoporosis 873
  - Pruritus ani 895
    - causes 895
    - treatment 895
  - Pruritus associated with vaginal discharge (leucorrhoea) 663
    - bacterial vaginosis 664
    - Chlamydia trachomatis* 665
    - Neisseria gonorrhoeae* 665
    - symptomatology of vaginal discharge 665
    - trichomonas infection 664
    - vaginal discharge 663
    - vaginal yeast infection 663
  - Pruritus vulvae and vulvodinia 662
    - causes 663
    - natural defence mechanisms 663
  - Pruritus without vaginal discharge 666
    - allergy and drug sensitivity 667
    - animal and fungal parasitic infections 666
    - chronic vascular changes 668
      - investigation 668
      - treatment 669
    - conditions of the urinary tract 666
    - diseases of the anus and rectum 666
    - epithelial disorders of the vulva 668
    - generalized pruritus 666
    - psychological factors 668
    - skin diseases not specific to the vulva 666
  - Pseudo-meigs' syndrome 500
  - Psychological sex 238
    - transsexuality 238
    - transvestism 238
  - Psychosomatic and sociological aspects of gynaecology 2
    - clinical methods 2
    - history 2
    - physical examination 6
      - abdomen 6
      - breasts 6
      - general 6
      - pelvic examination 8
    - special tests and accessory aids to diagnosis 12
      - ancillary services 12
      - colposcopy and colposcopy microscopy 12
      - cytology 12
      - examination under anaesthesia 12
    - symptoms 4
      - menstrual function 5
      - pain 4
      - trivial symptoms 4
  - Puberty and adolescence 111
    - abnormalities of puberty and adolescence 114
      - delayed puberty 115
      - menstrual disorders 115
      - obesity 114
    - management 118
    - management of adolescence; sex education 114
    - precocious puberty 116
      - adrenal cortical tumours 118
      - androgenic tumours of ovary 118
    - ectopic gonadotrophin production 118
    - oestrogenic tumours of the ovary 117
  - Puberty and PCOS 388
    - management 389
    - mechanism of onset of PCOS during puberty 388
- ## R
- Radiation dosage 569
  - Radiotherapy in carcinoma cervix 571
  - Radiotherapy in endometrial cancer 570
  - Radiotherapy machines 569
  - Rectal and anal pain 896

- Rectal prolapse 890  
causes 890  
treatment 891
- Recurrent (cyclical) buccal and vulvar ulceration 631  
aetiology 632  
clinical features 631  
treatment 633
- Recurrent early pregnancy loss 138  
aetiology 138  
coagulation investigation 138  
endocrinologic investigations 140  
immunologic investigations 140  
parental cytogenetic investigation 140
- Relapse 484  
carcinoma of the cervix complicated by other pelvic conditions 485  
further observation 484  
management of patients 484  
stump carcinoma 485  
therapeutic options for local relapse after primary surgery 484
- Retroverted gravid uterus 299  
impaction of the uterus 299  
diagnosis 299  
pathology 299  
treatment 300  
management of the uncomplicated 300  
outcome and effects 299  
retroverted gravid uterus 300  
sacculomy of the uterus 300
- Rhabdomyosarcomas 515
- Routes of hysterectomy 886
- Rubin's insufflation 735
- Rupture and perforation of the uterus 260
- S**
- Salpingectomy and salpingo-oophorectomy 153
- Salpingo-oophoritis 350  
aetiology 350  
clinical features 353  
pathology 351
- Sarcoidosis 330
- Sarcoma of the uterus 512  
pathology 512
- Schauta's operation 885
- Schistosomiasis (bilharzia) 331
- Screening for breast diseases 183  
genetics (familial) 183  
reproductive factor 184  
risk factors 183
- Sex chromosomal intersex 226  
characteristic 227  
primary micro-orchidism 229  
triple X syndrome 229  
Turner syndrome 226  
YY syndrome 230
- Sex determination in the foetus and its anomalies 220
- Sexually transmitted diseases 310  
chancroid (soft sore) 316  
diagnosis 316  
pathology and clinical features 316  
treatment 316
- gonorrhoea 313  
diagnosis 315  
pathology and clinical features 313  
treatment 315
- syphilis 311  
aetiology 311  
clinical features 311  
diagnosis 312  
treatment 313
- Short-wave therapy 951
- Special clinical types of bleeding 612  
abnormal bleeding 615  
causes 614  
evaluation 615  
investigation and treatment 614  
menopausal transition 615  
non-menstrual bleeding 612  
ovulation bleeding 612  
causes 612  
clinical features 612  
treatment 612
- perimenopausal bleeding 612  
postmenopausal bleeding 613  
prepubertal bleeding 612  
precocious puberty 612  
pubertal bleeding 612  
vaginal ultrasonography 615
- Specialised treatment schedules 243  
male hermaphroditism 243  
testicular feminization syndrome 243  
true hermaphroditism 243  
Turner's syndrome 244
- Spontaneous abortion 131  
clinical varieties 135  
complete abortion 136  
incomplete abortion 136
- inevitable abortion 135  
missed abortion 137  
septic abortion 137  
threatened abortion 135  
pathology 131
- Supporting pessaries 948
- Supports of the genital organs 46  
uterus 46  
vagina 46
- Suppression of lactation 179
- Suppurative thrombophlebitis of the pelvic veins 360  
aetiology and pathology 360  
clinical features 360  
treatment 360
- Syndromic approach to vaginal discharge 661
- T**
- Termination of pregnancy 830  
diseases of pregnancy 832  
ethical and legal considerations 830  
fetal disease and malformation 832  
indications for therapeutic abortion 831  
lunchtime abortions 838  
menstrual regulation 838  
methods of terminating pregnancy 832  
first-trimester termination 833  
mid-trimester abortion 833  
morbidity 836  
mortality 836  
surgical methods 835  
pre-existing maternal disease 831
- Therapeutic agents used in the treatment of gynaecological cancer 564  
alkylating agents 564  
antimetabolites 565  
antitumour antibiotics 565  
chemotherapy toxicity 565  
alopecia 565  
bone marrow suppression 565  
cardiotoxicity 566  
nausea and vomiting 565  
renal toxicity 565
- cisplatin and carboplatin 564  
taxanes 565
- Therapeutic ratio 569
- Torsion of pelvic organs 304  
aetiology 305  
adhesions, bands and tumours in adjacent organs 306

- defaecation and micturition 306
  - idiopathic 307
  - movement of the trunk 306
  - pregnancy and the
    - puerperium 306
    - unusual mobility of organs 305
  - differential diagnosis 307
  - torsion of abnormal organs 305
    - ovary 305
    - pedunculated leiomyoma 305
    - tube 305
    - uterus 305
  - torsion of the normal organs 304
    - tube and ovary 304
    - uterus 304
  - treatment 307
  - Transcutaneous electric nerve
    - stimulation (TENS) 952
  - Transrectal sonography 14
  - Transvaginal sonography 14
  - Transvestism and trans-sexuality 696
  - Tumour associated antigens (TAA) 574
  - Tumours of Bartholin's gland 450
    - Bartholin's cyst 450
      - aetiology 450
      - clinical features 450
      - complications 450
      - pathology 450
      - treatment 451
    - neoplasms of Bartholin's gland 451
  - Tumours of the cervix uteri 464
    - benign neoplasm 465
      - adenoma:adenofibroma 466, 488
      - angioma and allied tumours 466
      - papilloma 465
    - carcinoma of the cervix 467
      - aetiology 467, 490
      - complications 472
      - pathology 470
      - physical signs 472
      - symptoms 471
    - cervical screening 472
    - cysts of the cervix 464
      - cysts of embryonic tissues 464
      - endometriotic or endocervicotic cysts 465
    - enlargements of cervix 464
    - screening guidelines 472
      - clinical staging of disease 474
      - diagnosis 473
      - prognosis 474
      - treatment 475
  - Tumours of the corpus uteri 487
    - benign neoplasms 488
      - adenoma 488
      - aetiology 490
      - effect of pregnancy on leiomyomas 494
      - general effects 492
      - leiomyoma 488
      - menstrual disturbance 492
      - pressure symptoms 493
      - symptoms 492
      - symptoms related to pregnancy 493
    - enlargement of uterus 487
    - malignant neoplasms 503
      - adenocarcinoma in situ of the endometrium 504
      - carcinoma of the endometrium 503
      - chemotherapy and hormone therapy 512
      - choriocarcinoma 512
      - invasive carcinoma of the endometrium 505
      - treatment of vaginal metastases 512
    - polyps 487
  - Tumours of the fallopian tubes 517
    - benign neoplasms 517
      - primary 517
      - secondary 517
    - clinical features 518
    - pathology 518
    - treatment 519
  - Tumours of the inguinal canal 454
  - Tumours of the pelvic ligaments 521
    - cysts of the broad ligament and associated structures 521
      - clinical features 522
      - complications 522
      - pathology 521
      - treatment 523
  - Tumours of the vagina 456
    - benign neoplasms 458
      - clinical features 459
      - treatment 459
      - types 458
    - malignant neoplasms 459
      - adenocarcinoma 462
      - blood and lymphatic spread 463
      - melanoma 462
      - sarcoma 463
      - squamous cell carcinoma 459
      - vaginal intraepithelial neoplasia 459
    - swellings of the vagina 456
      - vaginal cysts 456
        - cyst of Skene's tubules 457
        - cysts of vestigial structures 456
        - diverticulum of urethra 457
        - endometriotic cysts 458
        - epidermoid cyst 457
  - Tumours of the vulva 440
    - benign neoplasms 442
      - condylomata acuminata 443
    - malignant neoplasms 444
      - basal cell carcinoma 449
      - malignant melanoma; sarcoma 449
      - squamous cell carcinoma 444
    - oedema 441
    - retention cysts 441
      - epidermoid cyst 442
      - hymeneal and clitoral cysts 442
      - sebaceous cysts 441
    - swellings of the vulva 440
    - varicose veins 441
- ## U
- Ultrasonography in gynaecology 741
  - Ultrasound of the uterus 744
  - Upward displacement of the uterus 293
    - causes 293
    - treatment 293
  - Urethral tumours 451
    - carcinoma of the urethra 454
      - clinical features 454
      - pathology 454
      - treatment 454
    - cysts of Skene's (paraurethral tubules 452
    - diverticulum of the urethra 452
    - granulomatous caruncle or diffuse caruncle 453
      - clinical features 453
      - pathology 453
      - treatment 453
    - prolapse of the urethra 451
      - acute 451
      - chronic 451
    - true caruncle 452
      - clinical features 453
      - pathology 452
      - treatment 453
    - urethral caruncle 452
  - Urinary 263
    - causes 264
    - clinical features 265

- diagnosis 265  
 treatment 266  
   conservative treatment 266  
   surgery for complicated  
     fistulas 268  
   surgery for ureteric fistulas 267  
   surgery for urethrovaginal  
     fistulas 268  
   surgery for uterovesical  
     fistulas 267  
   surgery for vesicovaginal  
     fistulas 267  
 types 263  
 Urinary problems 839  
   bladder dysfunction 839  
     bladder irritability and  
       instability 839  
     causes 840  
     diseases of the central nervous  
       system 842  
     diseases of the vulva and  
       vagina 842  
     functional – the psychogenic  
       bladder 842  
     hypotonic bladder 843  
     mechanical factors 840  
   enuresis 854  
     aetiology 854  
     management and treatment 855  
     natural variability in age 854  
     organic disease 854  
     psychological disturbances 854  
   incontinence of urine 847  
     continual incontinence 847  
     overflow incontinence 847  
     stress incontinence 848  
     urge incontinence 847  
   investigation of urinary  
     problems 844  
   urethral sphincter dysfunction 843  
   urinary retention and difficulty in  
     micturition 855  
   urinary tract infections in  
     women 859  
 Urinary symptoms at menopause 870  
 Use of progesterone for HRT 880  
 Uterine bleeding 83  
   menstruation 84  
     anovular menstruation 85  
     mechanism of bleeding from the  
       endometrium 85  
 Uterine corpus 422  
   endometrial hyperplasia 422  
     aetiology 424  
     clinical features 424  
     pathology 422  
     treatment 424  
   squamous cell metaplasia of the  
     endometrium 425  
     aetiology 425  
     pathology 425  
     treatment 426  
 Uterus 209  
   absence 209  
   cochleate uterus 210  
     clinical features 211  
     pathology 210  
     treatment 211  
   congenital hypertrophy of cervix 211  
   conical cervix and pinhole os 211  
   hypoplasia 210  
     causes 210  
     clinical features 210  
     treatment 210  
   types 210
- V**
- Vagina 211, 409  
   absence 211  
     clinical features 211, 409  
     pathology and aetiology 211, 409  
     treatment 212, 409  
   congenital atresia and stricture 213  
   double vagina (duplication)  
     septate and subseptate vagina 214  
   vaginal adenosis 409  
   vaginal intraepithelial neoplasia 409  
   vaginal hypoplasia 213  
 Vaginal atresia 206  
   clinical features 207  
   differential diagnosis 207  
   pathology 206  
   treatment 207  
 Vaginal burns 253  
   causes 253  
   effects 253  
   treatment 253  
 Vaginal cycle 87  
 Vaginal discharge 656  
   general considerations 656  
   investigation of vaginal  
     discharge 660  
     clinical history 660  
     examination 661  
     treatment 661  
   types and causes 657  
     bacterial vaginosis 658  
     chronic cervicitis 659  
     inflammatory discharge 658  
     neoplasms 659  
     pathological discharges 657  
     physiological discharges 657  
     rarities 660  
     urinary and faeculent  
       discharges 660  
 Vaginal discharge after operations 923  
 Vaginal packing-tamponade 950  
 Vaginitis 339  
   bacterial vaginosis (BV) 345  
   Candida vaginitis 343  
   other vaginal infections 346  
   senile vaginitis (atrophic  
     vaginitis) 339  
   trichomonas vaginitis and urethritis  
     (trichomoniasis) 340  
   vaginitis (vulvovaginitis) in  
     infancy 339  
     aetiology and pathology 339  
     clinical features 339  
     diagnosis 339  
     treatment 339  
 Various types of hormonal and non-  
   hormonal pharmaco-  
   logical agents 878  
   natural oestrogens 878  
   semisynthetic oestrogens 879  
   synthetic oestrogens 879  
 Venous thromboembolism 805  
 Vicarious menstruation 634  
   cause 634  
   clinical features 634  
   treatment 634  
 Vulva 214, 400  
   abnormalities of the hymen 215  
   absence, gross underdevelopment  
     and duplication 214  
   aetiology 402  
   atresia of the labia minora 215  
   diagnosis 403  
   hypertrophy of the clitoris 215  
   hypertrophy of the labia minora 215  
     pathology 215  
     symptoms 215  
     treatment 215  
   hypoplasia 214  
     bifid clitoris (diphallus) 214  
   pathology 400  
   symptoms 403  
   treatment 403

- Vulvar and oral epithelial abnormalities 405
- Vulvar intraepithelial neoplasia 405
  - clinical features 407
  - diagnosis 408
  - incidence and aetiology 405
  - pathology 406
  - treatment 408
- Vulvitis 333
  - acute simple 334
  - diabetic vulvitis 337
  - elephantiasis 337
  - pyogenic infections 333
  - recurrent genital (and buccal) ulceration 336
  - schistosomiasis 336
  - tuberculosis of the vulva 336
- Vulvodynia 669
  - advantages and limitations of syndromic management 673
  - classification by syndromes 671
  - clinical approach 670
  - STI risk assessment for women 671
  - syndromic approach 670
  - treatment guidelines 672
  - vaginal discharge syndromes 671
  - vestibulitis 675